

4

3

2

NOTES:

(NI) 1. FIT / FORM / FUNCTION SHALL FOLLOW PS-E.008.

BILL OF MATERIAL (CURRENT LEVEL)

ITEM	PT/ASSY	DESCRIPTION	TYPE	QTY.
I	12467-8	NIPPLE 3/4-14 NPT X 'A'	PART	1

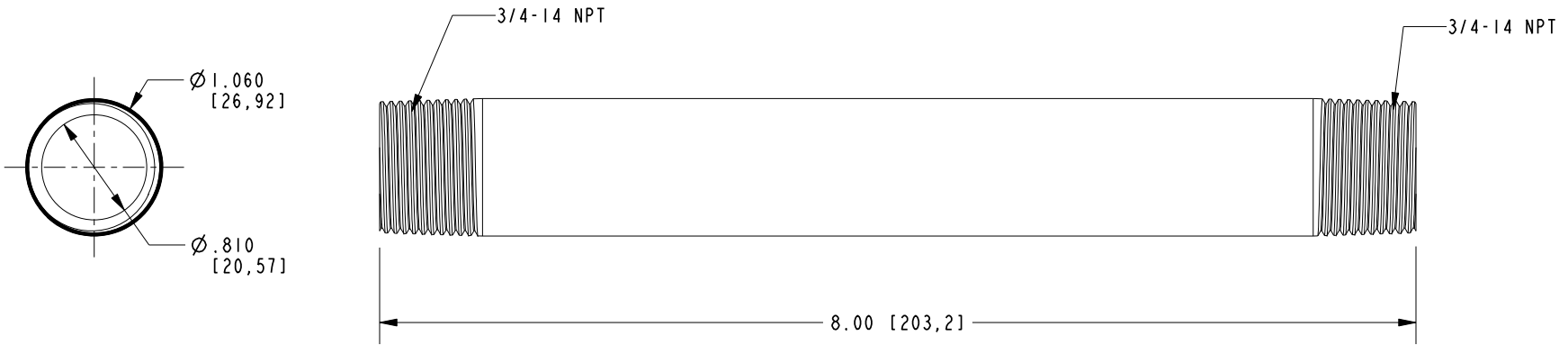
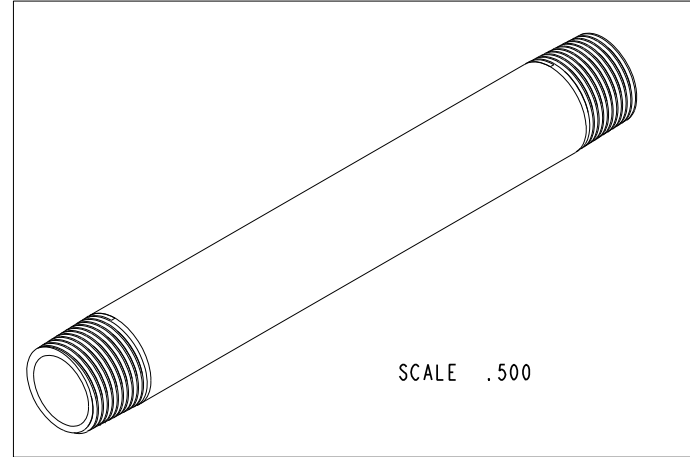

COPYRIGHT 2005 BRASSTECH, INC.  
 THESE DRAWINGS AND THE DESIGNS  
 DEPICTED HEREIN ARE THE PROPRIETARY  
 PROPERTY OF BRASSTECH. ANY USE  
 OR REPRODUCTION IS SUBJECT TO  
 THE EXPRESS APPROVAL OF BRASSTECH.  
 UNAUTHORIZED USE IS STRICTLY  
 PROHIBITED. ALL RIGHTS RESERVED.

TESTING	-	-	-
ASSEMBLY	-	-	-
PLATING	-	-	-
POLISHING	-	NEXT ASSY	USED ON
MACHINING	-	APPLICATION	
TOOLING FIXTURE #	REMOVE ALL BURRS AND SHARP EDGES		

UNITS ARE: INCHES [MM]	
TOLERANCES ARE:	
FRACTIONS	DECIMALS ANGLES
$\pm 1/16"$	$\pm .01$ $\pm 1^\circ$
.X $\pm .1$ [2,5]	.XX $\pm .06$ [1,5]
(X.XXX) DENOTES CRITICAL DIMS. ALL THREADS ARE CRITICAL	
DRAWN	R.S. 08/06/18
CHECKED	J.M. 08/06/18
APPROVED	J.M. 08/06/18

**BRASSTECH** 2001 CARNEGIE AVE.  
 INCORPORATED SANTA ANA, CA 92705  
 (949) 417-5207

3/4" NPT NIPPLE

DWG NO. 200-8108

SCALE .750 REF. - SHEET | OF |

ZONE	REV	DESCRIPTION	DATE	APPROVED
-	-	EN-3678	08/06/18	J.M.

4

3

2