

NOTES:

1. TO INSPECT ASSEMBLY, FOLLOW FIRST ARTICLE AND IN PROCESS INSPECTION SHEET.

2. TORQUE TO 15-20 FT-LBS.

3. ATTACH 1/2" ELBOW TO VALVE BODY USING CABLE TIE.

4. IF CARTRIDGE STEM LENGTH IS TOO SHORT
OPTIONAL STEM EXTENSION KIT #1-384 CAN
BE PURCHASED TO EXTEND STEM LENGTH.

BILL OF MATERIAL (CURRENT LEVEL)

ITEM	PT/ASSY	DESCRIPTION	TYPE	QTY.
1	11989	VALVE BODY, IN-WALL LAV 1/2" NPT	PART	1
2	98042	WARNING LABEL	PART	1
3	92289	1/2" ELBOW	PART	1
4	91476	CABLE TIE	PART	1
5	98029	STICKER, 14-16 FT-LBS TORQUE	PART	2
6	1-452	T/S CARTRIDGE-COLD	ASSEMBLY	1
7	1-453	T/S CARTRIDGE-HOT	ASSEMBLY	1
8	1-455	NIPPLE ASM	ASSEMBLY	2
9	91787	MUD COVER, VALVE 3/4"	PART	2

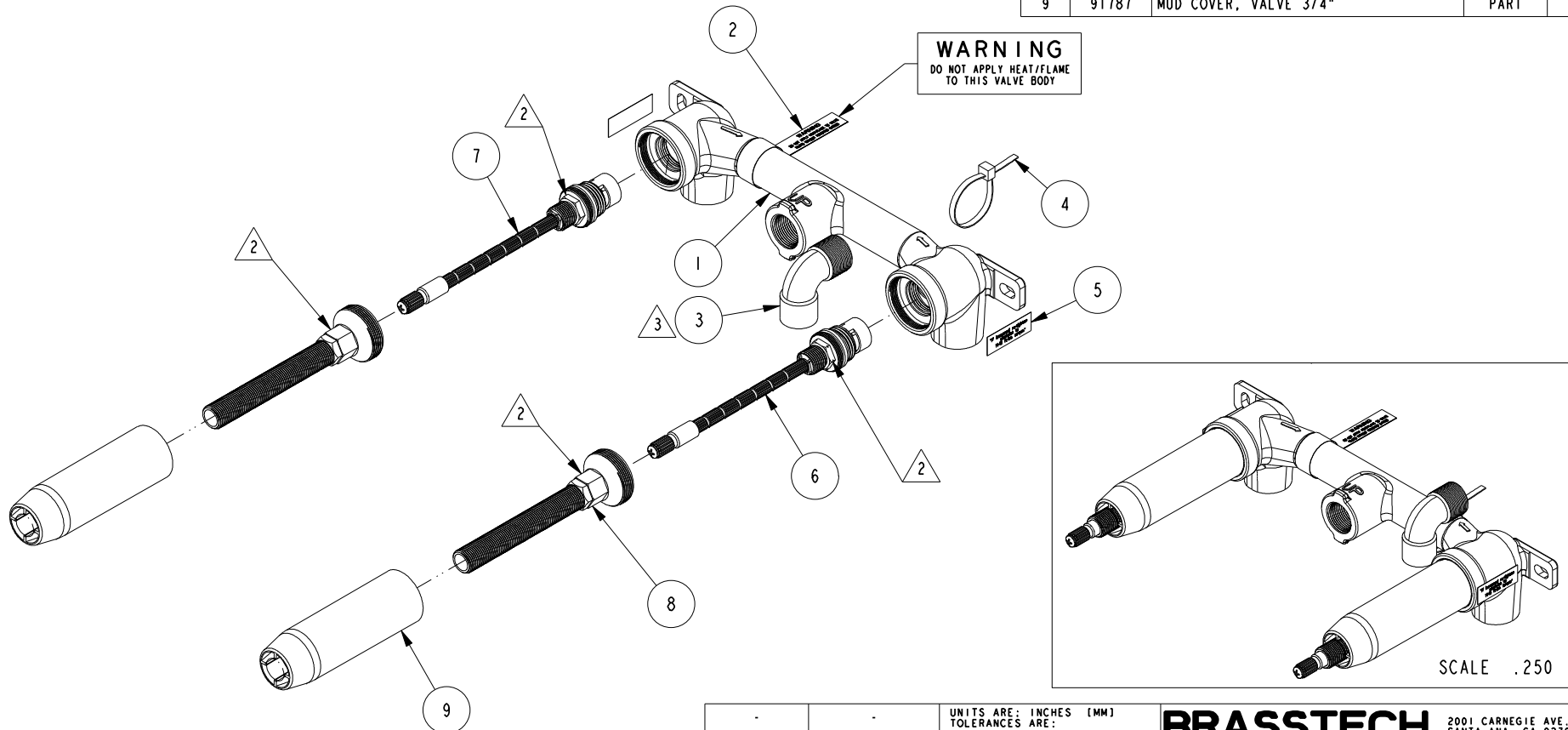

WARNING
DO NOT APPLY HEAT/FLAME
TO THIS VALVE BODY

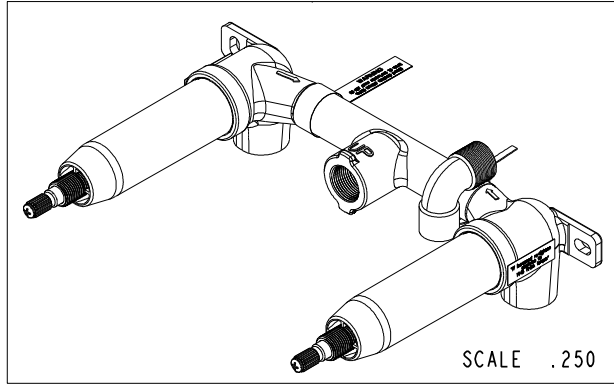

TESTING	-	-	-
ASSEMBLY	-	-	-
PLATING	-	-	-
POLISHING	-	NEXT ASSY	USED ON
MACHINING	-	APPLICATION	
TOOLING FIXTURE #	REMOVE ALL BURRS AND SHARP EDGES		

UNITS ARE: INCHES [MM]
TOLERANCES ARE:
FRACTIONS DECIMALS ANGLES
±1/16" .X ±.1 [2.5] ±1°
.XX ±.06 [1.5]
(X.XXX) DENOTES CRITICAL DIMS.
ALL THREADS ARE CRITICAL
DRAWN JIMSON 01/13/20
CHECKED C.G. 01/13/20
APPROVED C.G. 01/13/20

BRASSTECH 2001 CARNEGIE AVE.
INCORPORATED SANTA ANA, CA 92705
(949) 417-5207

TUB - VALVE ROUGH

-	A	EN-4300kk	03/22/21	R.S.
-	-	EN-3961A	01/13/20	C.G.
ZONE	REV	DESCRIPTION	DATE	APPROVED

DWG NO.	1-500U	REV	A
SCALE	.275	REF.	-
SHEET	1	OF	2

COPYRIGHT 2005 BRASSTECH, INC.
THESE DRAWINGS AND THE DESIGNS
DEPICTED HEREIN ARE THE PROPRIETARY
PROPERTY OF BRASSTECH. ANY USE
OR REPRODUCTION IS SUBJECT TO
THE EXPRESS APPROVAL OF BRASSTECH.
UNAUTHORIZED USE IS STRICTLY
PROHIBITED. ALL RIGHTS RESERVED.

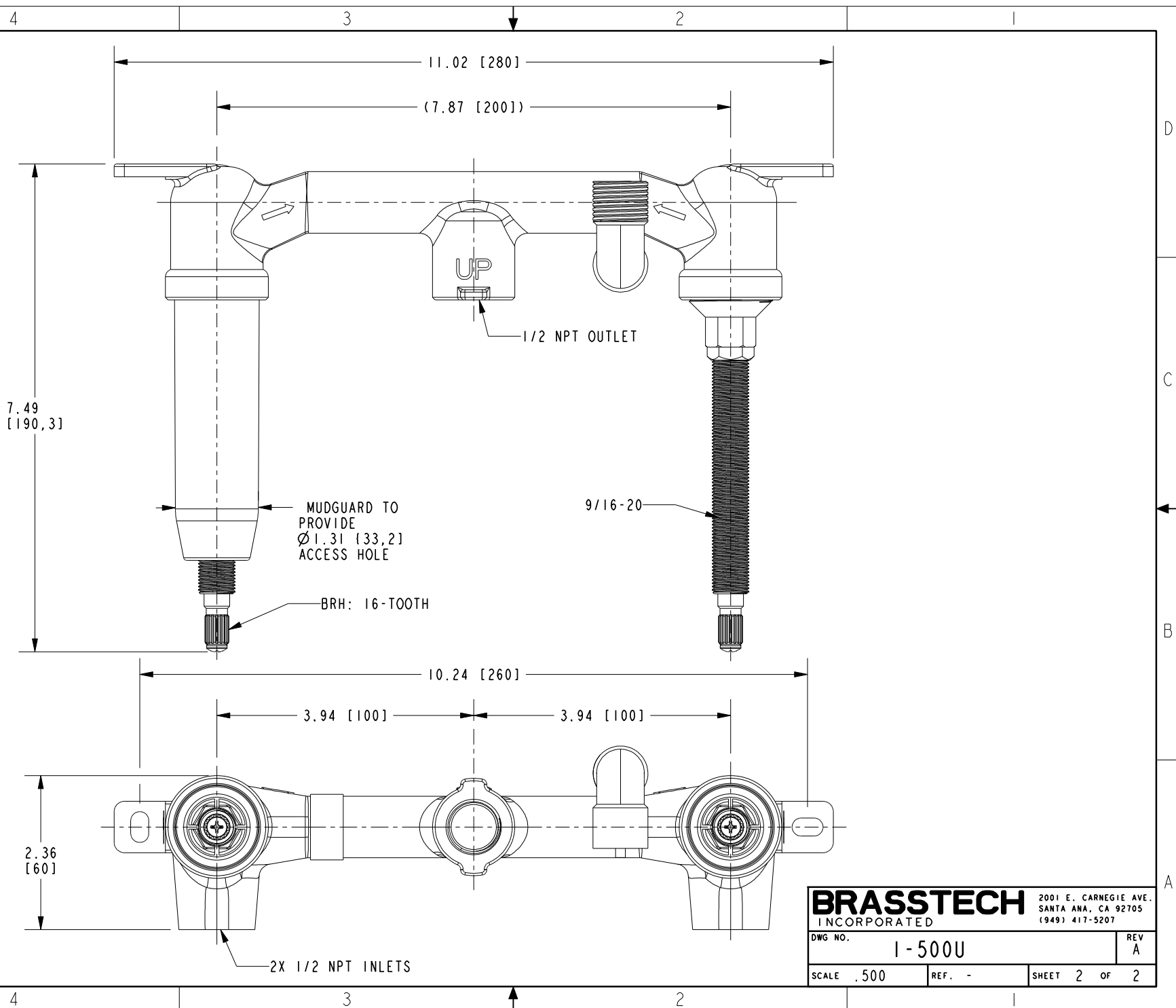

BRASSTECH		2001 E. CARNEGIE AVE. SANTA ANA, CA 92705 (949) 417-5207
DWG NO.	1-500U	REV A
SCALE .500	REF. -	SHEET 2 OF 2