

9/16-20

BRH: 16-TOOTH

Ø 1.58 [40,1]

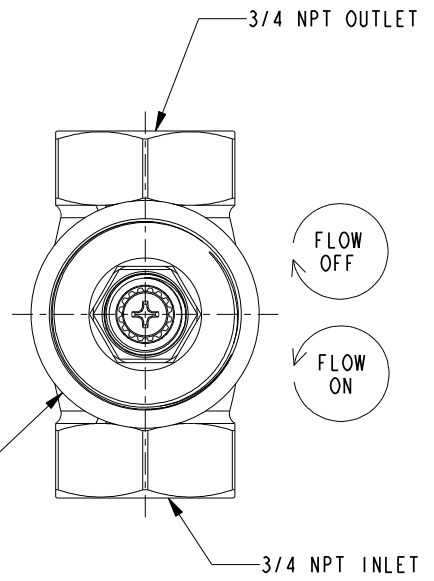

<b>BRASSTECH</b>		2001 E. CARNEGIE AVE. SANTA ANA, CA 92705 (949) 417-5207	
DWG NO.	1-607U	REV	A
SCALE	.750	REF.	-
		SHEET	2 OF 2