

NOTES:

1. TO INSPECT ASSEMBLY, FOLLOW FIRST ARTICLE AND IN PROCESS INSPECTION SHEET.

- 2 APPLY LOCTITE 680.
- 3 CUT AND SHORTEN O-RING BY .13" TO .20" IN LENGTH BEFORE INSTALLING.
- 4 SLIT O-RING BEFORE INSTALLING.
- 5 APPLY LOCTITE 242.
- 6 CONNECT WHITE AND RED TUBINGS TOGETHER AND WATER TEST WHOLE UNIT.
- 7 BAG 92194 IN A SEPARATE BAG.
- 8 REWORK CARTRIDGE ASSY IF THE HANDLE DOES NOT RETURN TO THE 'OFF' POSITION AUTOMATICALLY AFTER WATER TESTING.
- 9 INSTALLATION TORQUE: 8-14 LB-FT.
- 10 INSTALLATION TORQUE: 78 LB-IN +/-6 LB-IN.
- 11 LUBRICATE SPRING WITH DOW CORNING III SILICONE COMPOUND.
- 12 APPLY LIGHT FILM OF DOW CORNING III SILICONE COMPOUND.

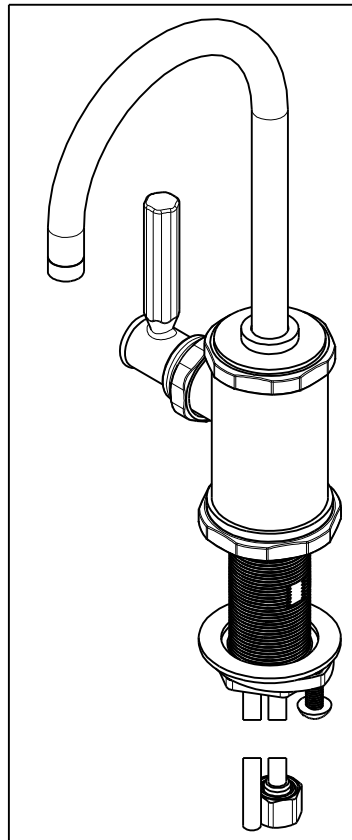

BILL OF MATERIAL (CURRENT LEVEL)

ITEM	PT/ASSY	DESCRIPTION	TYPE	QTY.
1	1-393	1-1/8 18 UNEF MOUNTING KIT	ASSEMBLY	1
2	1-431	RED SUPPLY LINE	ASSEMBLY	1
3	1-432	BLUE SUPPLY LINE	ASSEMBLY	1
4	1-433	GREY SUPPLY LINE	ASSEMBLY	1
5	5-052	SPOUT ASM	ASSEMBLY	1
6	5-061	ADAPTER/CARTRIDGE ASSY	ASSEMBLY	1
7	20-292	HANDLE HUB ASM	ASSEMBLY	1
8	20-294	ESCUTCHEON ASM	ASSEMBLY	1
9	12512	BONNET	PART	1
10	12695	BODY CAP	PART	1
11	13070	RETAINER PLATE	PART	1
12	13288	BODY	PART	1
13	13289	NIPPLE	PART	1
14	50714	WATER DISP. CAR.T HOLDER	PART	1
15	50717	WATER DISP SPOUT RETAINER	PART	1
16	91017	O-RING, #2- 012, EPDM, 65-75 DURO, NSF 61	PART	2
17	91023	O-RING, #2- 019, EPDM, 65-75 DURO, NSF 61	PART	1
18	91382	O-RING, #2- 012, TEFLON,	PART	1
19	91383	O-RING, #2- 014, TEFLON, NSF 61	PART	1
20	91424	WSHR, .81 ID X .93 OD X .045 THK, FLT, PLST	PART	1
21	92016	SCRW, 10-24 X 3/4 SKT HD FLT PT SS	PART	1
22	92194	COUPLING, 3/8" X 1/4"	PART	1
23	98043	TAG LABEL, HOT WATER WARNING	PART	1

-	F	EN-4300jj	07/22/21	R.S.
-	E	EN-3634A	11/25/19	C.G.
-	D	EN-3941	08/28/19	C.G.
-	C	EN-3862	05/09/19	C.G.
-	B	EN-3558a	01/01/19	V.V.
-	A	EN-3693	08/29/18	J.M
-	-	EN-3229	08/21/17	J.M
ZONE	REV	DESCRIPTION	DATE	APPROVED

COPYRIGHT 2005 BRASSTECH, INC. THESE DRAWINGS AND THE DESIGNS DEPICTED HEREIN ARE THE PROPRIETARY PROPERTY OF BRASSTECH. ANY USE OR REPRODUCTION IS SUBJECT TO THE EXPRESS APPROVAL OF BRASSTECH. UNAUTHORIZED USE IS STRICTLY PROHIBITED. ALL RIGHTS RESERVED.

TESTING	-	-	-
ASSEMBLY	-	-	-
PLATING	-	-	-
POLISHING	-	NEXT ASSY	USED ON
MACHINING	-	APPLICATION	
TOOLING FIXTURE #	REMOVE ALL BURRS AND SHARP EDGES		

UNITS ARE: INCHES [MM]
TOLERANCES ARE:
FRACTIONS DECIMALS ANGLES
±1/16" .X ±.1 [2.5] ±1°
.XX ±.06 [1.5]

(X.XXX) DENOTES CRITICAL DIMS.
ALL THREADS ARE CRITICAL

DRAWN	JINSON	07/22/21
CHECKED	R.S.	07/22/21
APPROVED	R.S.	07/22/21

BRASSTECH 2001 CARNEGIE AVE.
INCORPORATED SANTA ANA, CA 92705
(949) 417-5207

WATER DISPENSER - HOT

DWG NO.	3190-5613	REV	F
SCALE	.375	REF.	-
SHEET	1	OF	3

