

NOTES:

1. TO INSPECT ASSEMBLY, FOLLOW FIRST ARTICLE AND IN PROCESS INSPECTION SHEET.

2. APPLY LOCTITE 680.

3. APPLY TORQUE 6-8 IN-LB.

4. APPLY 65-70 IN-LB.

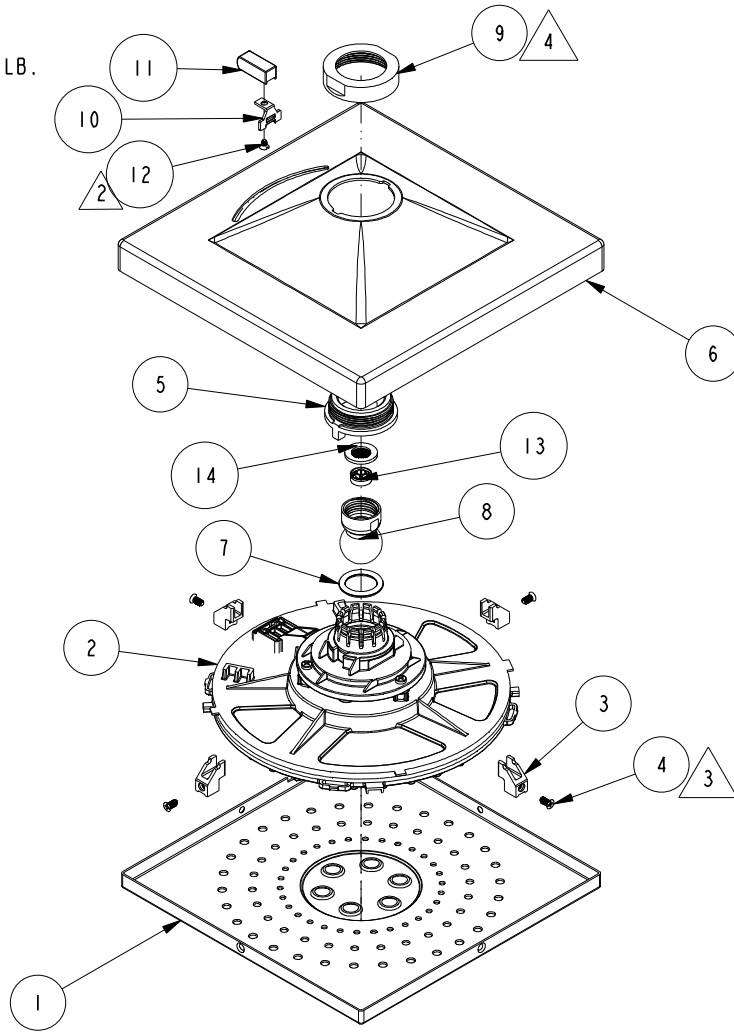

BILL OF MATERIAL (CURRENT LEVEL)

ITEM	PT/ASSY	DESCRIPTION	TYPE	QTY.
1	13314	SQUARE FACEPLATE	PART	1
2	1-392	SHOWER HEAD ENGINE	ASSEMBLY	1
3	13201	FACEPLATE TAB	PART	4
4	92895	SCRW, 6-32 X 5/16 FLT HD SS	PART	4
5	12961	COMPRESSION NUT	PART	1
6	13315	SHOWER HEAD SHELL	PART	1
7	91220	O-RING, #2-210, EPDM, 65-75 DURO	PART	1
8	80018	PIVOT BALL	PART	1
9	12963	SHOWER HEAD COLLAR NUT	PART	1
10	12964	LEVER TAB	PART	1
11	12965	LEVER	PART	1
12	92196	SCRW, 4-40 X 3/16 SLT FLT HD SS	PART	1
13	12833	FLOW REGULATOR, 1.8 GPM MAX	PART	1
14	91606	GASKET W/ FILTER SCREEN	PART	1

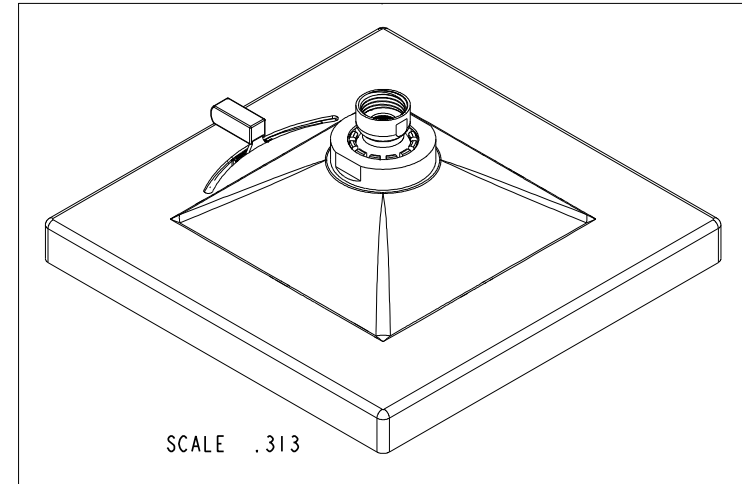

-	E	EN-4300w	03/10/21	R.S.
-	D	EN-3978o	11/06/20	J.M.
-	C	EN-3999	10/17/19	C.G.
-	B	EN-3853	01/08/19	C.G.
-	A	EN-3766	12/06/18	C.G.
-	-	EN-3551	05/18/18	V.V.
ZONE	REV	DESCRIPTION	DATE	APPROVED

COPYRIGHT 2005 BRASSTECH, INC. THESE DRAWINGS AND THE DESIGNS DEPICTED HEREIN ARE THE PROPRIETARY PROPERTY OF BRASSTECH. ANY USE OR REPRODUCTION IS SUBJECT TO THE EXPRESS APPROVAL OF BRASSTECH. UNAUTHORIZED USE IS STRICTLY PROHIBITED. ALL RIGHTS RESERVED.

TESTING	-	-	-
ASSEMBLY	-	-	-
PLATING	-	-	-
POLISHING	-	NEXT ASSY	USED ON
MACHINING	-	APPLICATION	
TOOLING FIXTURE #	REMOVE ALL BURRS AND SHARP EDGES		

UNITS ARE: INCHES [MM]	
TOLERANCES ARE:	
FRACTIONS	DECIMALS
±1/16"	.X ±.1 [2.5]
	.XX ±.06 [1.5]
(X.XXX) DENOTES CRITICAL DIMS.	
ALL THREADS ARE CRITICAL	
DRAWN	MANJUNATH 10/17/19
CHECKED	C.G. 10/17/19
APPROVED	C.G. 10/17/19

BRASSTECH		2001 CARNEGIE AVE. SANTA ANA, CA 92705 (949) 417-5207	
INCORPORATED			
TRANSITIONAL SQ SHOWER HEAD			
DWG NO.	2159		REV E
SCALE	.225	REF. -	SHEET 1 OF 2

