

NOTES:

1. TO INSPECT ASSEMBLY, FOLLOW FIRST ARTICLE AND IN PROCESS INSPECTION SHEET.

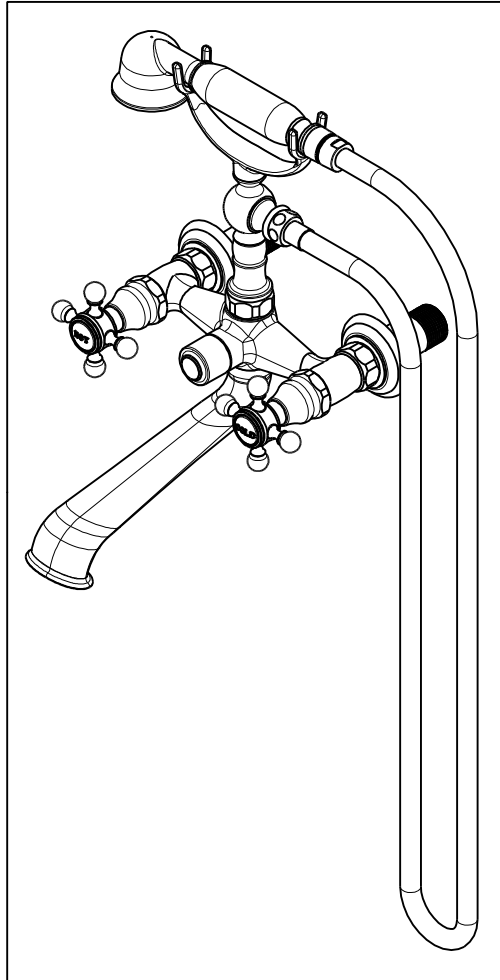

**BILL OF MATERIAL (CURRENT LEVEL)**

ITEM	PT/ASSY	DESCRIPTION	TYPE	QTY.
1	12894	BODY - FOR 933,934	PART	1
2	2-220	RISER ASM	ASSEMBLY	1
3	10442	SEAT FOR CARTRIDGE	PART	2
4	1-326	W/S CARTRIDGE FRICTION - HOT	PART	1
5	1-325	W/S CARTRIDGE FRICTION - COLD	PART	1
6	12062	ADAPTER - 20-T X 16-T	PART	2
7	91039	WSHR, .625 ID X 1.00 OD X .125 THK, RUBBER	PART	2
8	12458	NIPPLE 3/4 X 2.8"	PART	2
9	281	HANDSHOWER ASM	ASSEMBLY	1
10	284	59 IN. SPIRAL SHOWER HOSE	ASSEMBLY	1
11	12585	SPOUT	PART	1
12	91022	O-RING, #2- 018, EPDM, 65-75 DURO, NSF 61	PART	1
13	91020	O-RING, #2-016, EPDM, 65-75 DURO, NSF 61	PART	2
14	10332	HEX NUT	PART	2
15	2-221	FLANGE ASM	ASSEMBLY	2
16	92539	SCRW, M4X22 FLAT HD SOCKET HD CAP	PART	2
17	12518	BONNET	PART	2
18	2-141	HANDLE ONLY, HOT	ASSEMBLY	1
19	2-142	HANDLE ONLY, COLD	ASSEMBLY	1
20	20-260	DIVERTER ASM	ASSEMBLY	1
21	20-259	DIVERTER ASM	ASSEMBLY	1
22	13313	DIVERTER BUTTON	PART	1

ZONE	REV	DESCRIPTION	DATE	APPROVED
-	C	EN-4300h	01/05/21	R.S.
-	B	EN-3565A	01/22/20	C.G.
-	A	EN-3150a	05/18/17	J.M.
-	-	EN-3058b	09/13/16	AN

COPYRIGHT 2005 BRASSTECH, INC. THESE DRAWINGS AND THE DESIGNS DEPICTED HEREIN ARE THE PROPRIETARY PROPERTY OF BRASSTECH. ANY USE OR REPRODUCTION IS SUBJECT TO THE EXPRESS APPROVAL OF BRASSTECH. UNAUTHORIZED USE IS STRICTLY PROHIBITED. ALL RIGHTS RESERVED.

TESTING	-	-	-
ASSEMBLY	-	-	-
PLATING	-	-	-
POLISHING	-	NEXT ASSY	USED ON
MACHINING	-	APPLICATION	
TOOLING FIXTURE #	REMOVE ALL BURRS AND SHARP EDGES		

UNITS ARE: INCHES [MM]  
TOLERANCES ARE:  
FRACTIONS DECIMALS ANGLES  
±1/16" .X ±.1 [2.5] ±°  
.XX ±.06 [1.5]

(X.XXX) DENOTES CRITICAL DIMS.  
ALL THREADS ARE CRITICAL

DRAWN	JINSON	01/05/21
CHECKED	R.S.	01/05/21
APPROVED	R.S.	01/05/21

**BRASSTECH** 2001 CARNEGIE AVE.  
INCORPORATED SANTA ANA, CA 92705  
(949) 417-5207

**EXPOSED TUB FILLER, WALL MOUNT**

DWG NO. **920-4282** REV **C**

SCALE .200 REF. - SHEET 1 OF 3

- 2. APPLY ADHESIVE LOCTITE 680.
- 3. TORQUE TO 15-20 FT-LB.
- 4. APPLY LOCTITE 242 IF SCREW DOES NOT HAVE NYLON PATCH.
- 5. TORQUE TO 11-14 FT-LB.

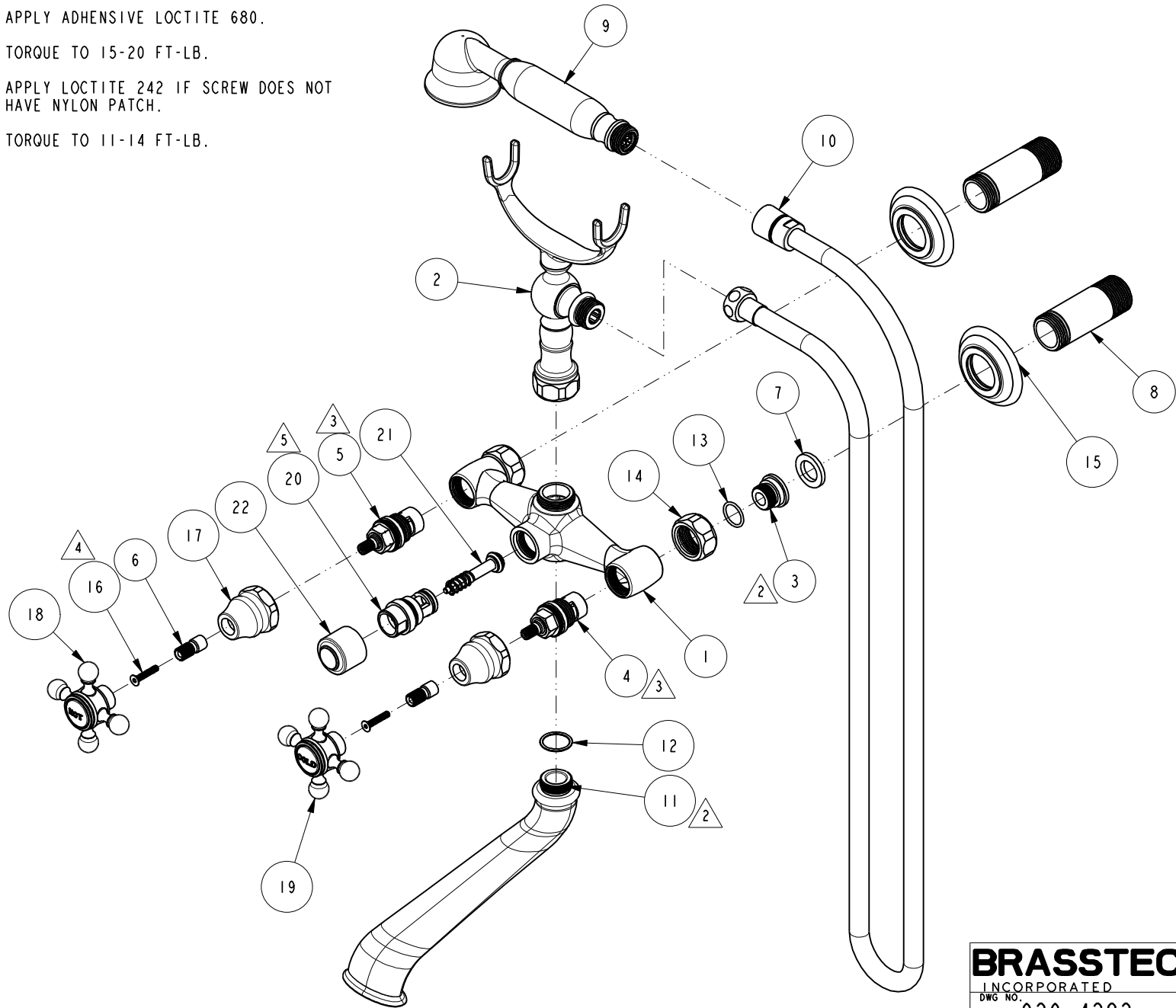

**BRASSTECH** 2001 CARNEGIE AVE.  
 INCORPORATED SANTA ANA, CA 92705  
 (949) 417-5207

DWG NO.	920-4282	REV	C
SCALE	.250	REF.	-
		SHEET	2 OF 3

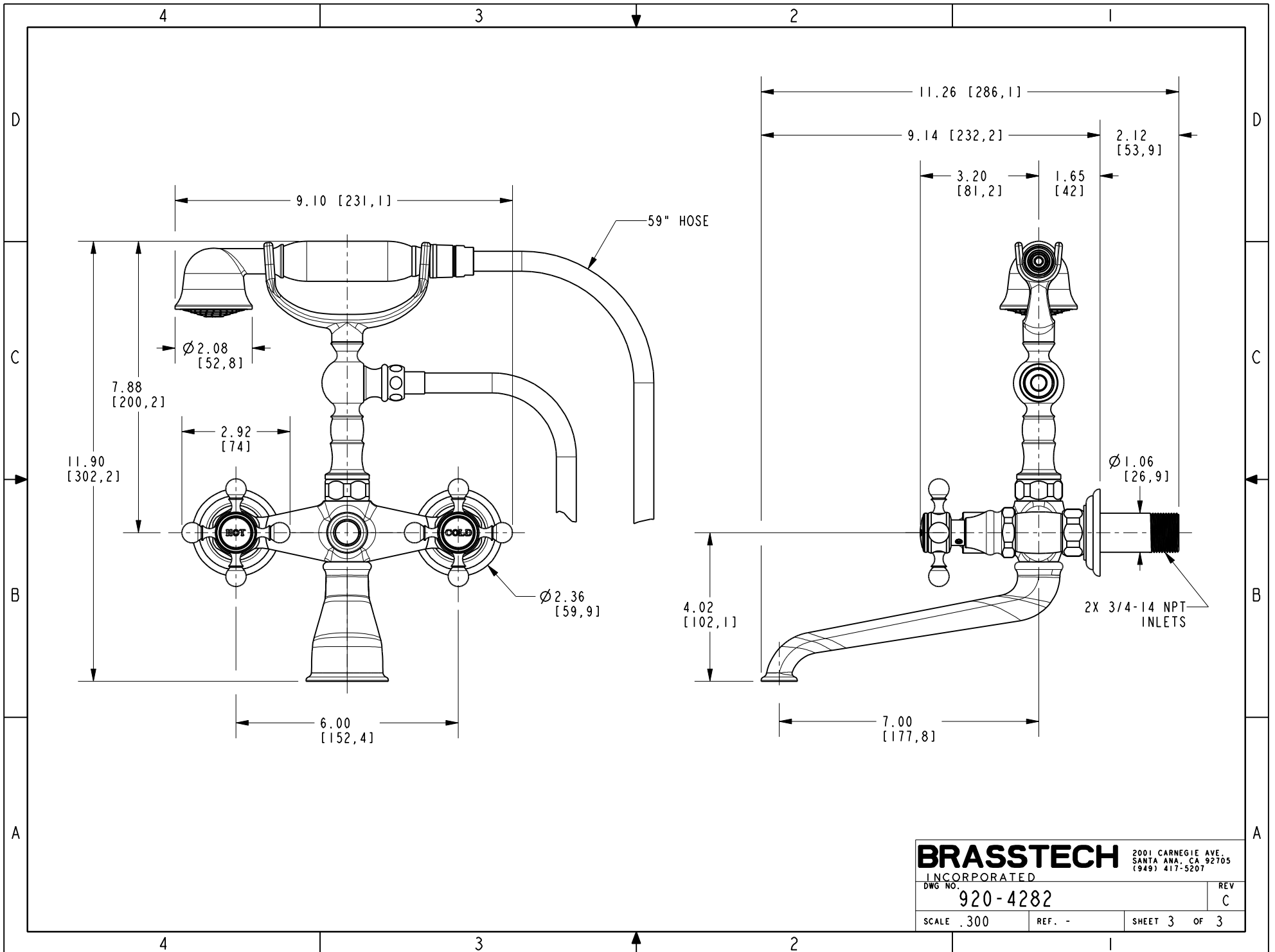

**BRASSTECH** 2001 CARNEGIE AVE.  
 INCORPORATED SANTA ANA, CA 92705  
 (949) 417-5207

DWG NO.	920-4282	REV	C
SCALE	.300	REF.	-
SHEET 3		OF 3	