

NOTES:

1. TO INSPECT ASSEMBLY, FOLLOW FIRST ARTICLE AND IN PROCESS INSPECTION SHEET.

BILL OF MATERIAL (CURRENT LEVEL)				
ITEM	PT/ASSY	DESCRIPTION	TYPE	QTY.
1	8-033	SHOWER PLATE ASM	ASSEMBLY	1
2	2-640	FLANGE ASSEMBLY	ASSEMBLY	1
3	200	SHOWER ARM 6" BRASS	PART	1
4	2155	SHOWER HEAD, CONTEMP	ASSEMBLY	1
5	3-594	LEVER HANDLE W/ESC.	ASSEMBLY	1

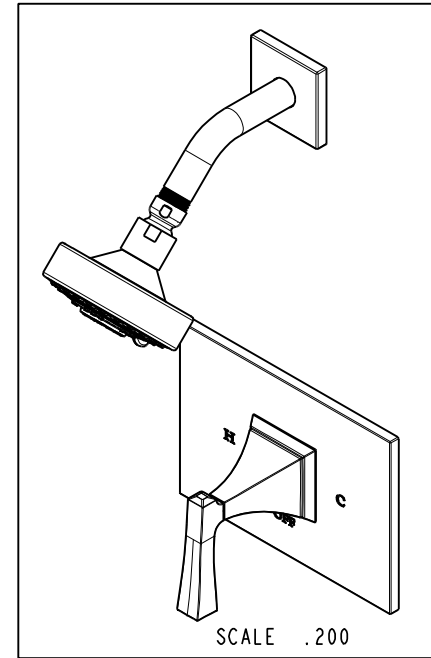
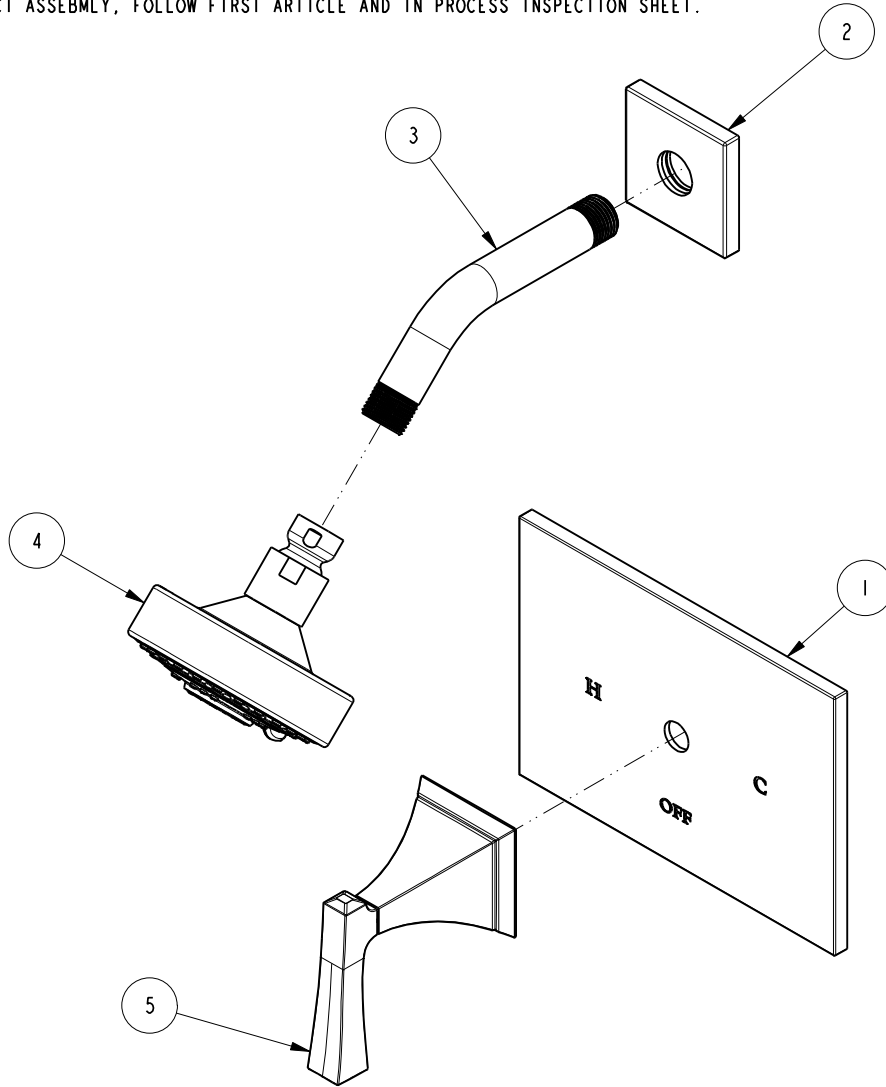

ZONE	REV	DESCRIPTION	DATE	APPROVED
-	C	EN-4300e	04/28/21	R.S.
-	B	EN-3178a	07/18/17	J.M.
-	A	EN-3185	11/11/16	R.S.
-	-	EN-2367b	05/27/15	J.M.

COPYRIGHT 2005 BRASSTECH, INC. THESE DRAWINGS AND THE DESIGNS DEPICTED HEREIN ARE THE PROPRIETARY PROPERTY OF BRASSTECH. ANY USE OR REPRODUCTION IS SUBJECT TO THE EXPRESS APPROVAL OF BRASSTECH. UNAUTHORIZED USE IS STRICTLY PROHIBITED. ALL RIGHTS RESERVED.

TESTING	-	-	-
ASSEMBLY	-	-	-
PLATING	-	-	-
POLISHING	-	NEXT ASSY	USED ON
MACHINING	-	APPLICATION	
TOOLING FIXTURE #	REMOVE ALL BURRS AND SHARP EDGES		

UNITS ARE: INCHES [MM]
TOLERANCES ARE:
FRACTIONS DECIMALS ANGLES
±1/16" .X ±.1 [2,5] ±1°
.XX ±.06 [1,5]

(X.XXX) DENOTES CRITICAL DIMS. ALL THREADS ARE CRITICAL			
DRAWN	JINSON	04/28/21	
CHECKED	R.S.	04/28/21	
APPROVED	R.S.	04/28/21	

BRASSTECH INCORPORATED
2001 CARNEGIE AVE.
SANTA ANA, CA 92705
(949) 417-5207

TRIM KIT TUB / SHOWER BP

DWG NO.	3-2574BP		REV	C
SCALE	.300	REF.	-	SHEET 1 OF 2

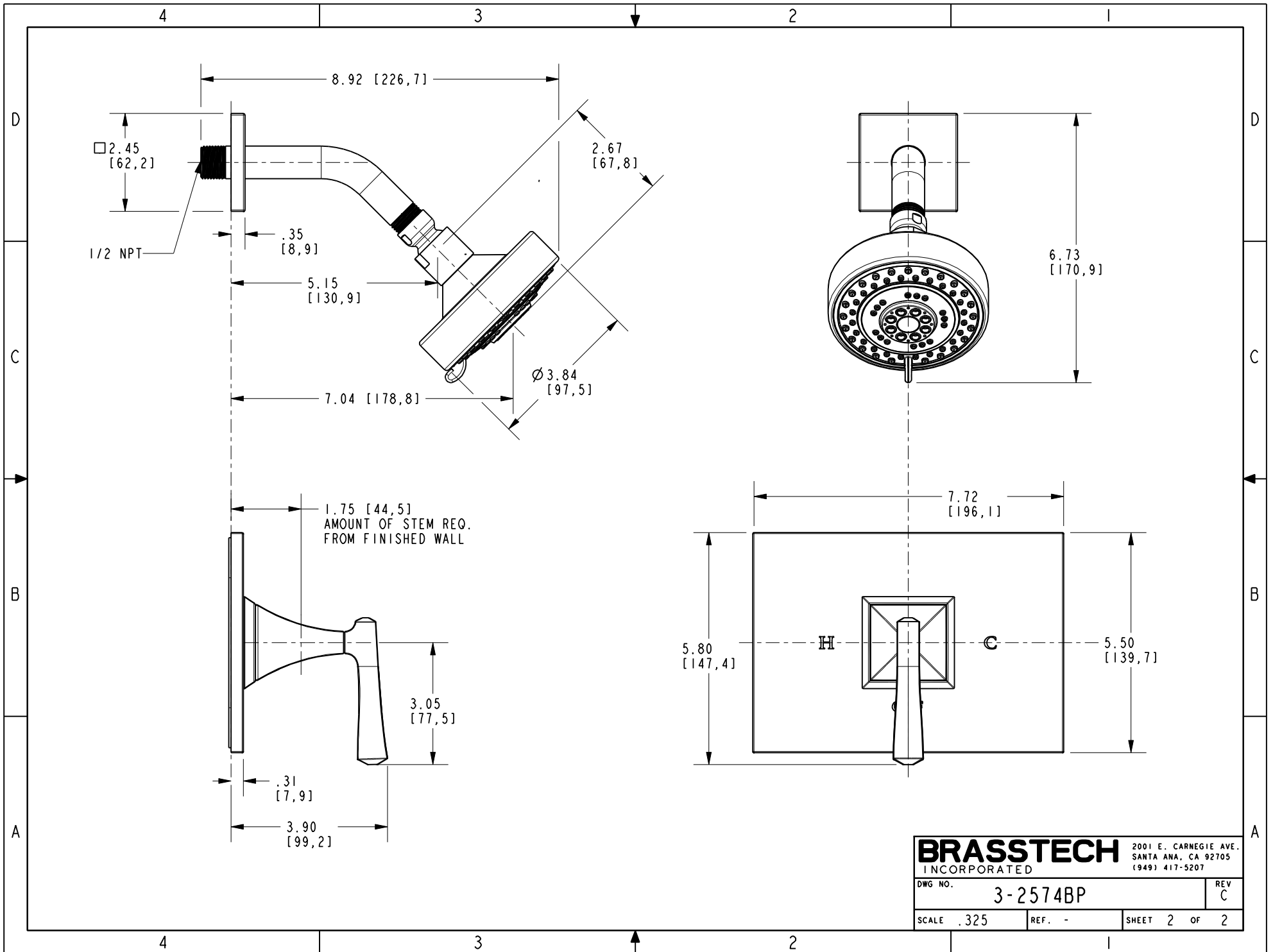

BRASSTECH		2001 E. CARNEGIE AVE. SANTA ANA, CA 92705 (949) 417-5207	
DWG NO.	3-2574BP		REV C
SCALE .325	REF. -	SHEET 2 OF 2	