

NOTES:

(N1) 1. TO INSPECT ASSEMBLY, FOLLOW FIRST ARTICLE AND IN PROCESS INSPECTION SHEET.

BILL OF MATERIAL (CURRENT LEVEL)

ITEM	PT/ASSY	DESCRIPTION	TYPE	QTY.
I	50843	TAIL PIECE	PART	I

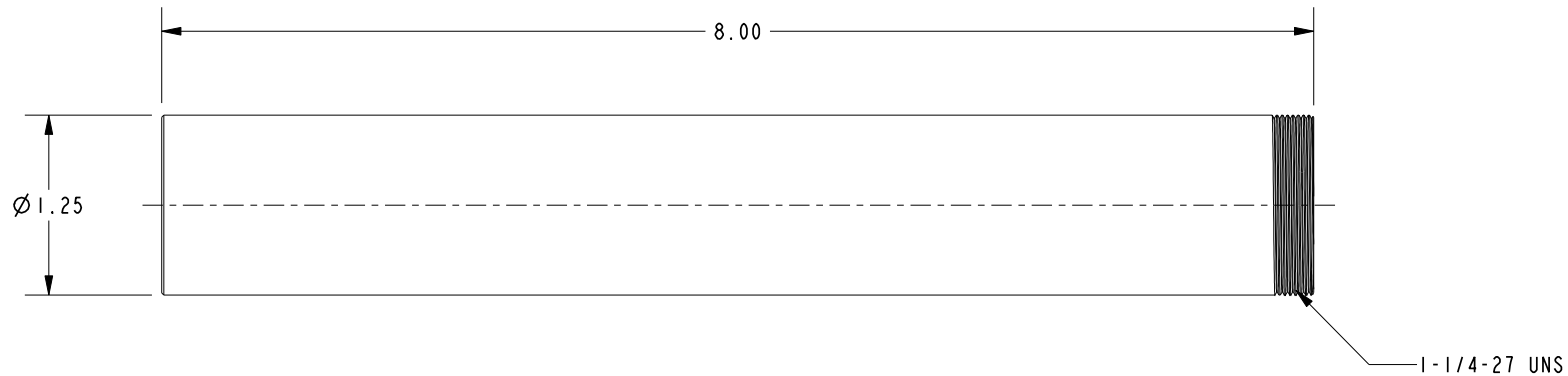
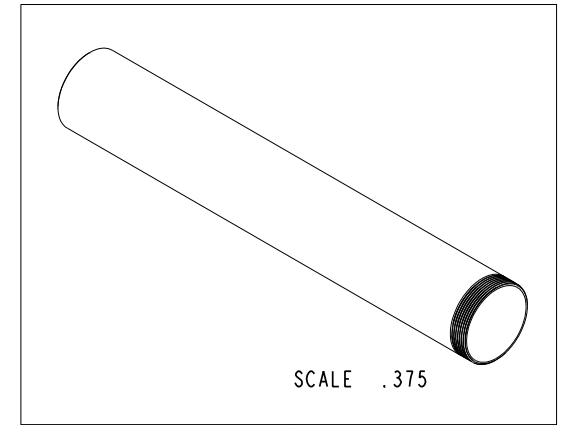

ZONE	REV	DESCRIPTION	DATE	APPROVED
-	C	EN-400311	10/11/21	N.S.
-	B	EN-1485	03/03/10	N.S.
-	A	EO-0937	01/30/08	P.M.
-	-	RELEASE	PRE '95	-

COPYRIGHT 2005 BRASSTECH, INC. THESE DRAWINGS AND THE DESIGNS DEPICTED HEREIN ARE THE PROPRIETARY PROPERTY OF BRASSTECH. ANY USE OR REPRODUCTION IS SUBJECT TO THE EXPRESS APPROVAL OF BRASSTECH. UNAUTHORIZED USE IS STRICTLY PROHIBITED. ALL RIGHTS RESERVED.

TESTING	-	-	-
ASSEMBLY	-	-	-
PLATING	-	-	324; 325; 326
POLISHING	-	NEXT ASSY	USED ON
MACHINING	-	APPLICATION	
TOOLING FIXTURE #	REMOVE ALL BURRS AND SHARP EDGES		

UNITS ARE: INCHES [MM]	
TOLERANCES ARE:	
FRACTIONS DECIMALS	ANGLES
±1/16"	.X ±.1 [2.5] ±1°
	.XX ±.06 [1.5]
(X.XXX) DENOTES CRITICAL DIMS. ALL THREADS ARE CRITICAL	
DRAWN	HMS 10/11/21
CHECKED	N. SANTOS 10/11/21
APPROVED	N. SANTOS 10/11/21

BRASSTECH 2001 CARNEGIE AVE. SANTA ANA, CA 92705 (949) 417-5207
INCORPORATED

TAIL PIECE

DWG NO. **327** REV C

SCALE .750 REF. - SHEET | OF |