

NOTES:

1. TO INSPECT ASSEMBLY, FOLLOW FIRST ARTICLE AND IN PROCESS INSPECTION SHEET.
2. APPLY LOCTITE 680.
3. CUT AND SHORTEN O-RING BY .13" TO .20" IN LENGTH BEFORE INSTALLING.
4. SLIT O-RING BEFORE INSTALLING.
5. APPLY LOCTITE 242.
6. CONNECT CLEAR AND RED TUBINGS TOGETHER AND WATER TEST WHOLE UNIT.
7. BAG 92194 IN A SEPARATE BAG.
8. REWORK CARTRIDGE ASSY IF THE HANDLE DOES NOT RETURN TO THE "OFF" POSITION AUTOMATICALLY AFTER WATER TESTING.
9. INSTALLATION TORQUE: 8-14 LB-FT.
10. INSTALLATION TORQUE: 78 LB-IN +/- 6 LB-IN
11. LUBRICATE SPRING WITH DOW CORNING III.
12. APPLY THIN FILM OF DOW CORNING III.

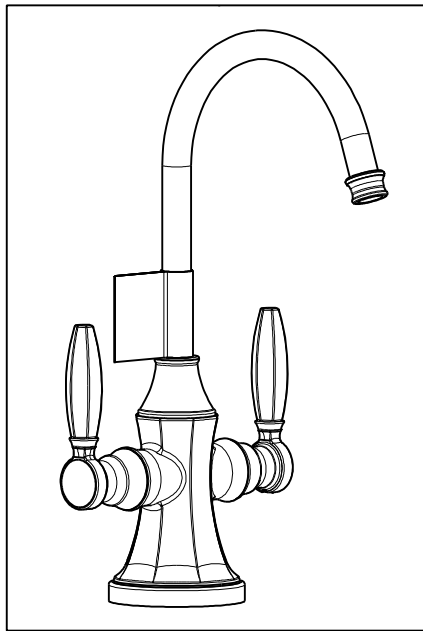

BILL OF MATERIAL (CURRENT LEVEL)

ITEM	PT/ASSY	DESCRIPTION	TYPE	QTY.
1	13280	WATER DISPENSER BODY, HOT & COLD	PART	1
2	11836	RETAINING RING	PART	1
3	12076	WATER DISPENSER BODY CAP	PART	1
4	50713	SPOUT, WATER DISP. (TRAD.)	PART	1
5	12077	ESCUTCHEON	PART	1
6	11733	SHELL, SPOUT, WATER DISP	PART	1
7	1-431	RED SUPPLY LINE	ASSEMBLY	1
8	1-432	BLUE SUPPLY LINE	ASSEMBLY	1
9	1-433	GREY SUPPLY LINE	ASSEMBLY	1
10	13070	RETAINER PLATE	PART	1
11	13289	NIPPLE	PART	1
12	91762	O-RING, #2-132, EP, 50 DURO - GREY	PART	1
13	92016	SCRW, 10-24 X 3/4 SKT HD FLT PT SS	PART	1
14	1-393	1-1/8 18 UNEF MOUNTING KIT	ASSEMBLY	1
15	92194	COUPLING, 3/8" X 1/4"	PART	1
16	91382	O-RING, #2- 012, TEFLON,	PART	1
17	91017	O-RING, #2- 012, EPDM, 65-75 DURO, NSF 61	PART	2
18	91383	O-RING, #2- 014, TEFLON, NSF 61	PART	1
19	98043	TAG LABEL, HOT WATER WARNING	PART	1
20	91023	O-RING, #2- 019, EPDM, 65-75 DURO, NSF 61	PART	1
21	5-061	ADAPTER/CARTRIDGE ASSY	ASSEMBLY	1
22	12151	HANDLE	PART	2
23	92000	SCREW 8 - 32 X 1/8 SS	PART	2
24	1-134	CARTR 3/8 HOT 1/4 TR	PART	1
25	11834	ADAPTER	PART	1
26	92477	SCRW, M4 X 16 SKT FLT HD SS	PART	1

ZONE	REV	DESCRIPTION	DATE	APPROVED
-	G	EN-4300jj	04/12/21	R.S.
-	F	EN-3634	07/16/20	C.G.
-	E	EN-3862	05/07/19	C.G.
-	D	EN-3722	02/08/19	C.G.
-	C	EN-3558o	04/12/21	R.S.
-	B	EN-3317	10/16/17	J.A.
-	A	EN-3131	08/29/16	N.S.
-	-	EN-2663	12/18/13	N.S.

COPYRIGHT 2005 BRASSTECH, INC. THESE DRAWINGS AND THE DESIGNS DEPICTED HEREIN ARE THE PROPRIETARY PROPERTY OF BRASSTECH. ANY USE OR REPRODUCTION IS SUBJECT TO THE EXPRESS APPROVAL OF BRASSTECH. UNAUTHORIZED USE IS STRICTLY PROHIBITED. ALL RIGHTS RESERVED.

TESTING	-	-	-
ASSEMBLY	-	-	-
PLATING	-	-	-
POLISHING	-	NEXT ASSY	USED ON
MACHINING	-	APPLICATION	
TOOLING FIXTURE #	REMOVE ALL BURRS AND SHARP EDGES		

UNITS ARE: INCHES [MM]
TOLERANCES ARE:
FRACTIONS DECIMALS ANGLES
±1/16" .X ±.1 [2.5] ±1°
.XX ±.06 [1.5]

(X.XXX) DENOTES CRITICAL DIMS.
ALL THREADS ARE CRITICAL

DRAWN	JINSON	04/12/21
CHECKED	R.S.	04/12/21
APPROVED	R.S.	04/12/21

BRASSTECH 2001 CARNEGIE AVE.
INCORPORATED SANTA ANA, CA 92705
(949) 417-5207

**METROPOLE HOT & COLD
WATER DISPENSER**

DWG NO. **1200-5603** REV **G**

SCALE .300 REF. - SHEET 1 OF 3

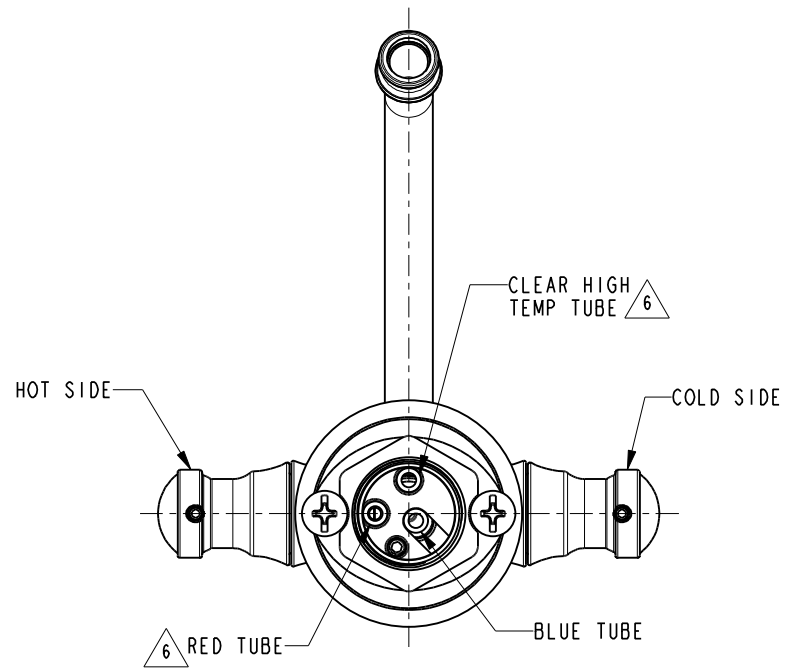
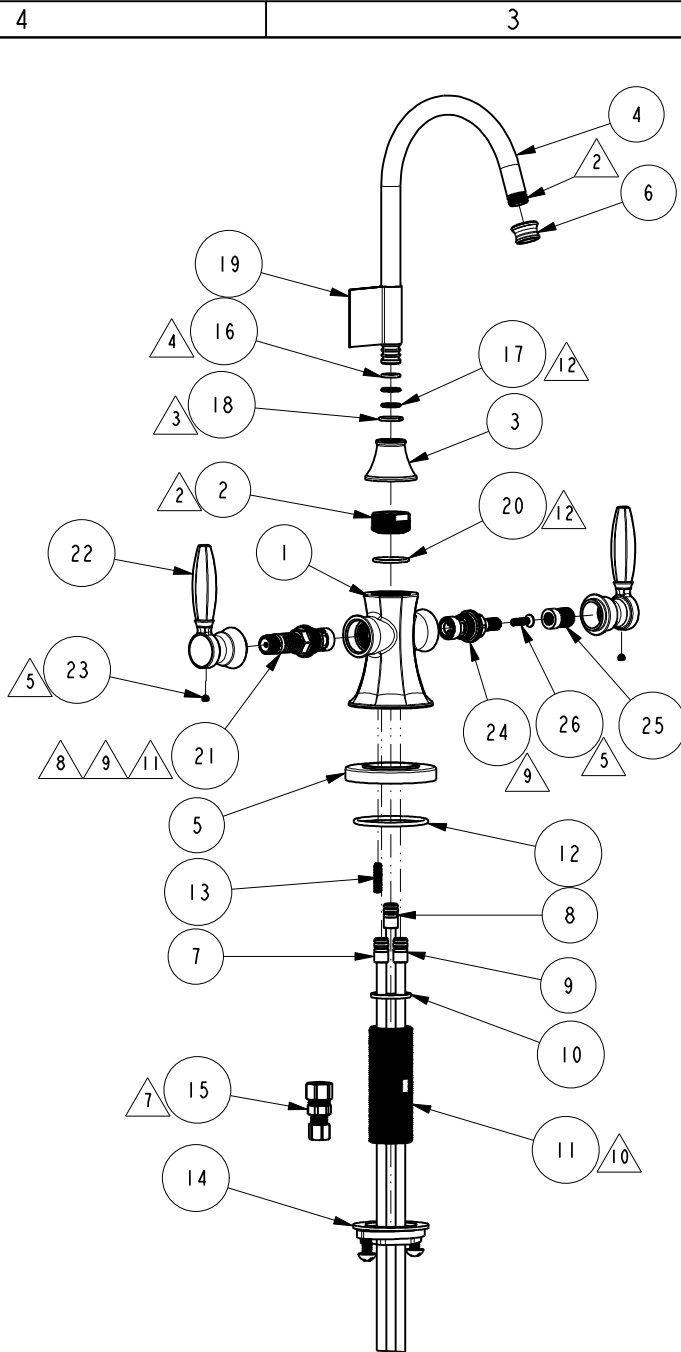

BOTTOM VIEW
SCALE .500

BRASSTECH		2001 E. CARNEGIE AVE. SANTA ANA, CA 92705 (949) 417-5207	
DWG NO.	1200-5603	REV G	
SCALE .200	REF. -	SHEET 2 OF 3	

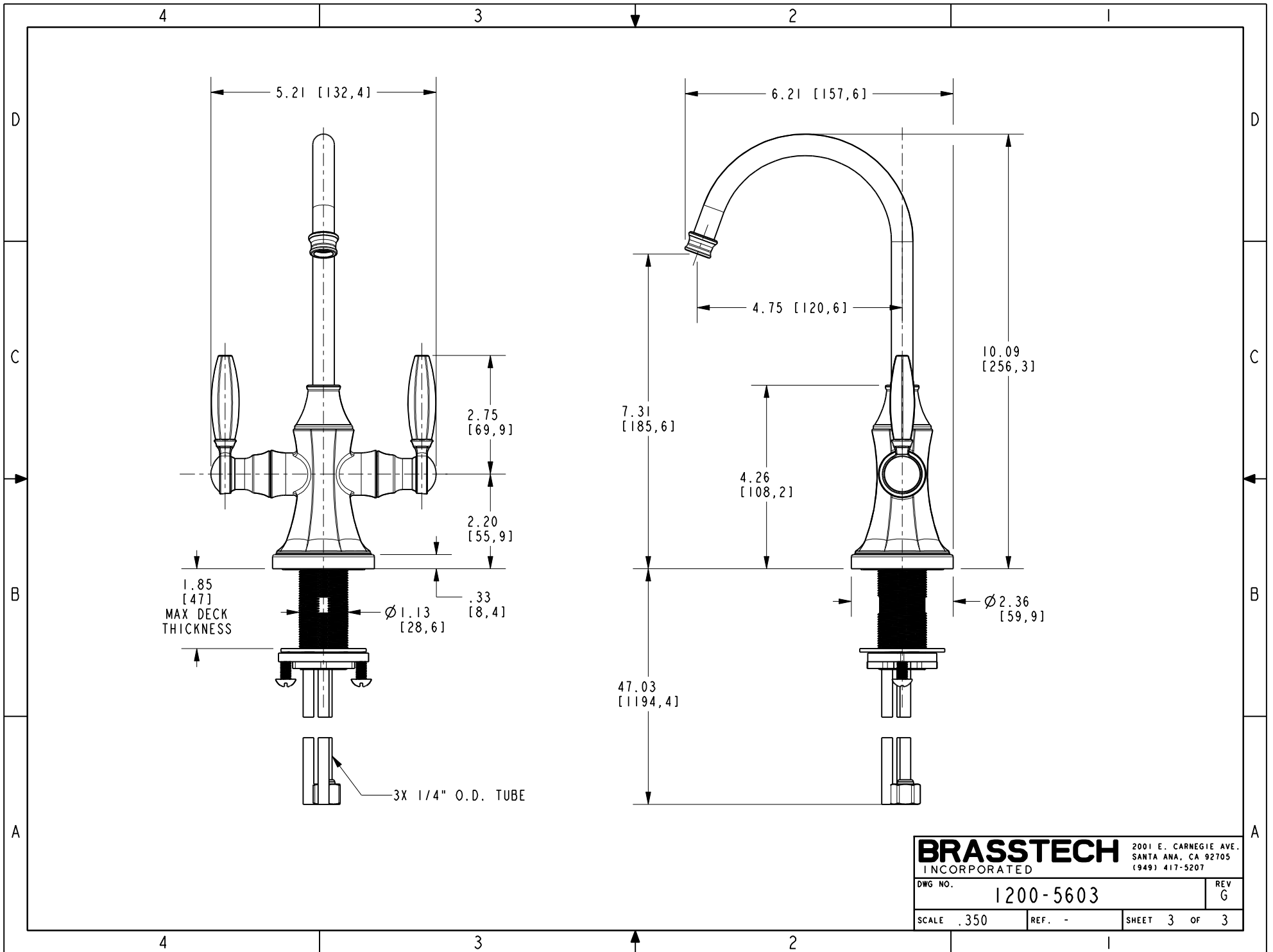

BRASSTECH		2001 E. CARNEGIE AVE. SANTA ANA, CA 92705 (949) 417-5207
DWG NO.	1200-5603	REV G
SCALE .350	REF. -	SHEET 3 OF 3