

NOTES:

1. TO INSPECT ASSEMBLY, FOLLOW FIRST ARTICLE AND IN PROCESS INSPECTION SHEET.

BILL OF MATERIAL (CURRENT LEVEL)

| ITEM | PT/ASSY | DESCRIPTION | TYPE | QTY. |
|------|---------|----------------------------|----------|------|
| 1 | 2-439 | COVERPLATE BP W/O DIVERter | ASSEMBLY | 1 |
| 2 | 3-570 | HANDLE/ ESC ASM | ASSEMBLY | 1 |

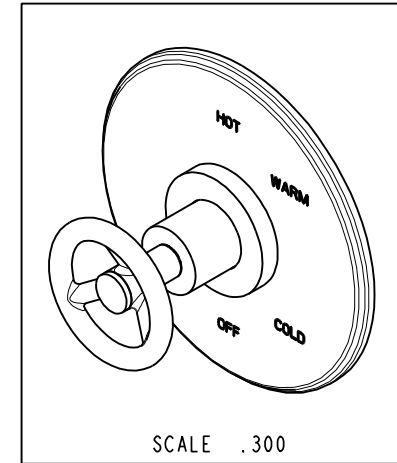
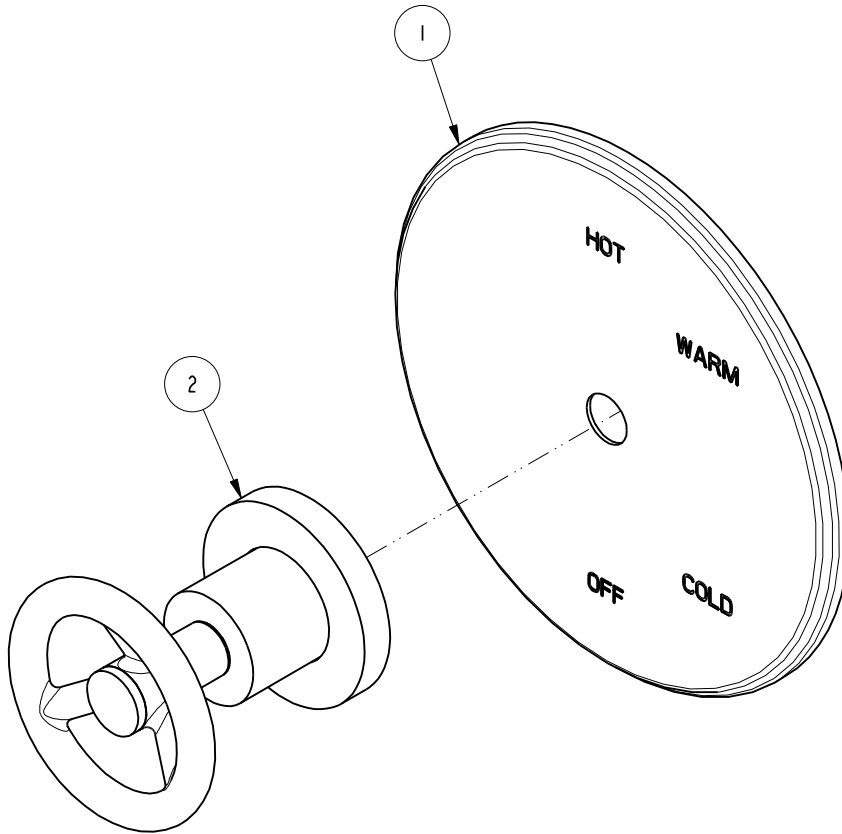

| ZONE | REV | DESCRIPTION | DATE | APPROVED |
|------|-----|-------------|----------|----------|
| - | B | EN-4300e | 04/28/21 | R.S. |
| - | A | EN-3242 | 01/27/17 | AN |
| - | - | EN-3005b | 03/21/16 | AN |

COPYRIGHT 2005 BRASSTECH, INC. THESE DRAWINGS AND THE DESIGNS DEPICTED HEREIN ARE THE PROPRIETARY PROPERTY OF BRASSTECH. ANY USE OR REPRODUCTION IS SUBJECT TO THE EXPRESS APPROVAL OF BRASSTECH. UNAUTHORIZED USE IS STRICTLY PROHIBITED. ALL RIGHTS RESERVED.

| | | | |
|-------------------|----------------------------------|-------------|---------|
| TESTING | - | - | - |
| ASSEMBLY | - | - | - |
| PLATING | - | - | - |
| POLISHING | - | NEXT ASSY | USED ON |
| MACHINING | - | APPLICATION | |
| TOOLING FIXTURE # | REMOVE ALL BURRS AND SHARP EDGES | | |

| | | | |
|--|----------------|----------|--|
| UNITS ARE: INCHES [MM] | | | |
| TOLERANCES ARE: | | | |
| FRACTIONS | DECIMALS | ANGLES | |
| ±1/16" | .X ±.1 [2,5] | ±1° | |
| | .XX ±.06 [1,5] | | |
| (.XXX) DENOTES CRITICAL DIMS. ALL THREADS ARE CRITICAL | | | |
| DRAWN | JINSON | 04/28/21 | |
| CHECKED | R.S. | 04/28/21 | |
| APPROVED | R.S. | 04/28/21 | |

BRASSTECH 2001 CARNEGIE AVE.
INCORPORATED SANTA ANA, CA 92705
(949) 417-5207

BP SHOWER TRIM LESS HAF

| | |
|------------|--------------|
| DWG NO. | REV |
| 4-2924BP | B |
| SCALE .500 | SHEET 1 OF 2 |

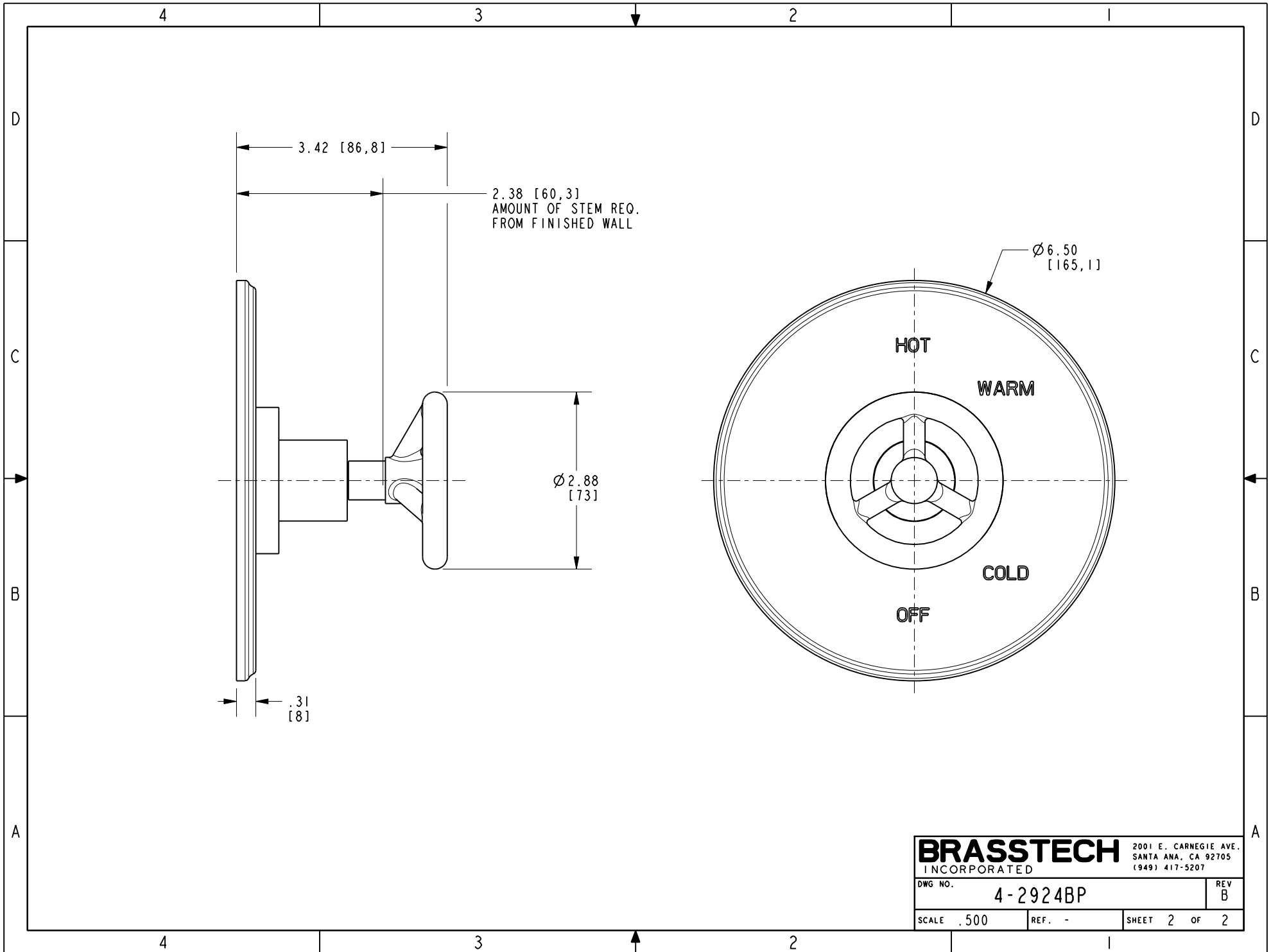

| | | |
|------------------|----------|--|
| BRASSTECH | | 2001 E. CARNEGIE AVE. SANTA ANA, CA 92705 (949) 417-5207 |
| DWG NO. | 4-2924BP | REV B |
| SCALE .500 | REF. - | SHEET 2 OF 2 |