

NOTES:

1. TO INSPECT ASSEMBLY, FOLLOW FIRST ARTICLE AND IN PROCESS INSPECTION SHEET.

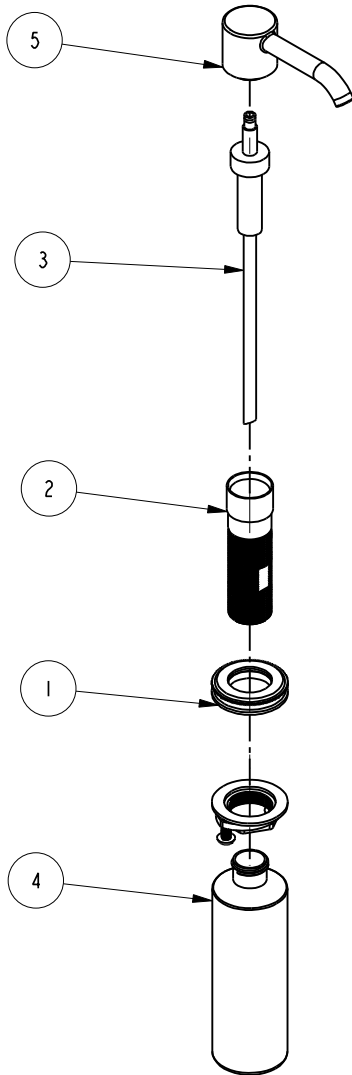

**BILL OF MATERIAL (CURRENT LEVEL)**

ITEM	PT/ASSY	DESCRIPTION	TYPE	QTY.
1	20-396	ESC-ASM	ASSEMBLY	1
2	20-391	BODY ASM - CONTEMPORARY	ASSEMBLY	1
3	125-8	SOAP DISPENSER PUMP ASM	ASSEMBLY	1
4	125-9	SOAP DISPENSER BOTTLE	PART	1
5	20-373	SOAP PUMP HEAD ASM CONTEMP	ASSEMBLY	1

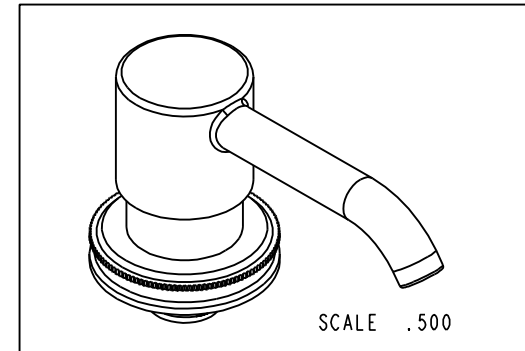

ZONE	REV	DESCRIPTION	DATE	APPROVED
-	C	EN-4300z	04/26/21	R.S.
-	B	EN-3625d	04/10/19	J.M.
-	A	EN-3558b	02/13/19	V.V.
-	-	EN-2980j	10/12/16	V.V.

COPYRIGHT 2005 BRASSTECH, INC. THESE DRAWINGS AND THE DESIGNS DEPICTED HEREIN ARE THE PROPRIETARY PROPERTY OF BRASSTECH. ANY USE OR REPRODUCTION IS SUBJECT TO THE EXPRESS APPROVAL OF BRASSTECH. UNAUTHORIZED USE IS STRICTLY PROHIBITED. ALL RIGHTS RESERVED.

TESTING	-	-	-
ASSEMBLY	-	-	-
PLATING	-	-	-
POLISHING	-	NEXT ASSY	USED ON
MACHINING	-	APPLICATION	
TOOLING FIXTURE #	REMOVE ALL BURRS AND SHARP EDGES		

UNITS ARE: INCHES [MM]		
TOLERANCES ARE:		
FRACTIONS DECIMALS	ANGLES	
±1/16"	.X ±.1 [2,5]	±1°
	.XX ±.06 [1,5]	
(X.XXX) DENOTES CRITICAL DIMS.		
ALL THREADS ARE CRITICAL		
DRAWN	JINSON	04/26/21
CHECKED	R.S.	04/26/21
APPROVED	R.S.	04/26/21

**BRASSTECH** 2001 CARNEGIE AVE.  
INCORPORATED SANTA ANA, CA 92705  
(949) 417-5207

SOAP DISPENSER, TAFT

DWG NO.	2940-5721	REV	C
SCALE	.200	REF.	-
SHEET	1	OF	2

