

4

3

2

D

D

C

C

B

B

A

A

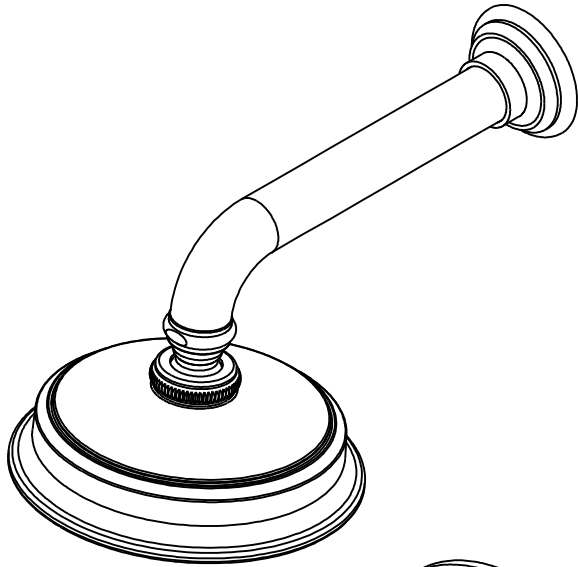

PN 1-594
SOLD SEPARATELY

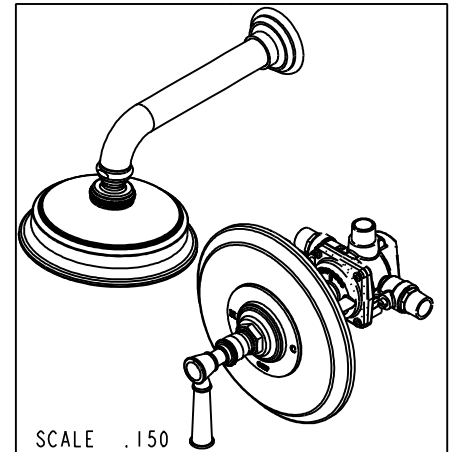
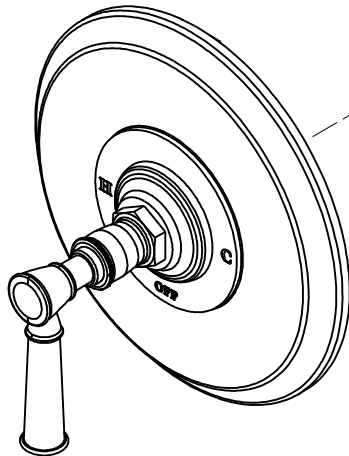
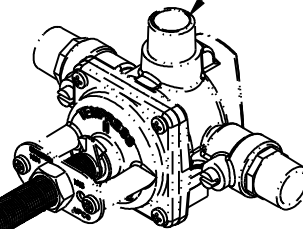

SCALE .150

BRASSTECH
INCORPORATED

2001 E. CARNEGIE AVE.
SANTA ANA, CA 92705
(949) 417-5207

DWG NO.	3-2914BP	REV	-
SCALE	.300	REF.	-
		SHEET	2 OF 3

4

3

2

NOTE:

- 1. CUT STEM TO DIMENSION SHOWN
- 2. CUT ALL THREADS 1" SHORTER THAN STEM

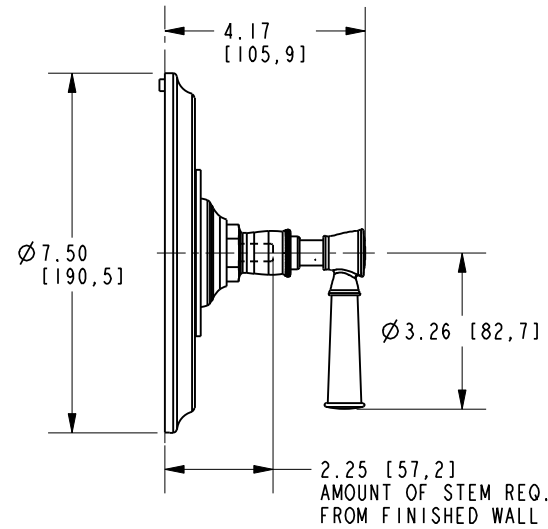
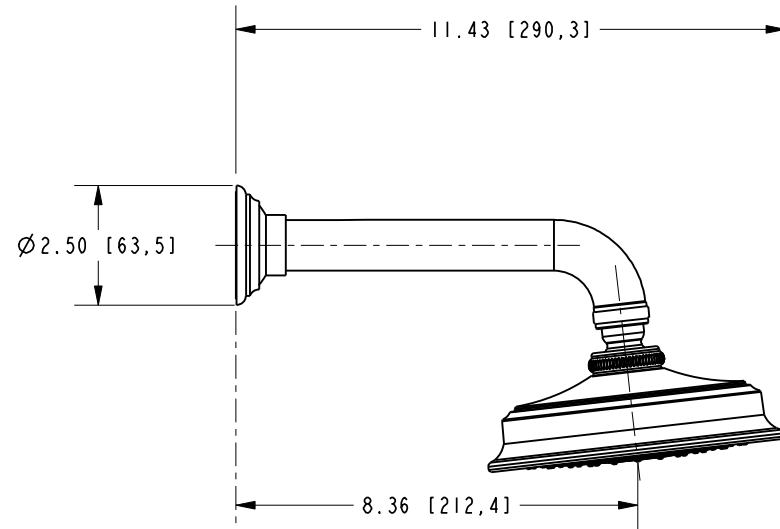
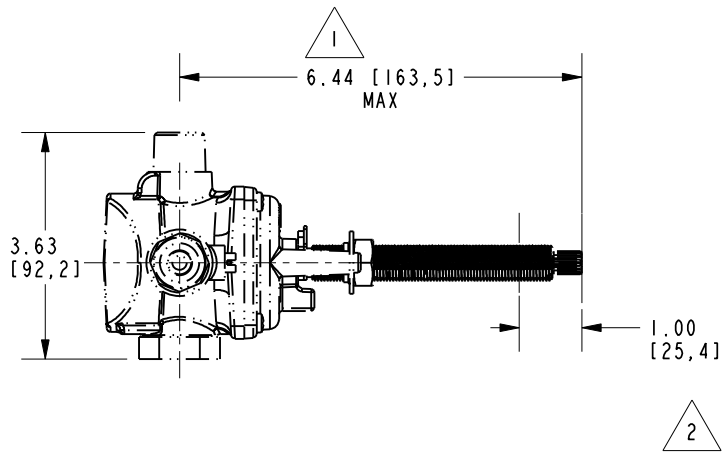
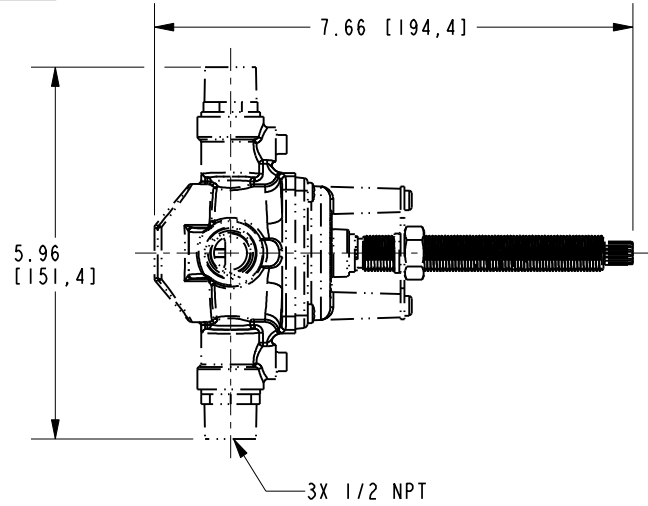

BRASSTECH		2001 E. CARNEGIE AVE. SANTA ANA, CA 92705 (949) 417-5207	
DWG NO.	3-2914BP	REV	-
SCALE	.325	REF.	-
		SHEET	3 OF 3