

4

3

2

1

NOTES:

(NI) 1. FIT / FORM / FUNCTION SHALL FOLLOW PS-E.008.

BILL OF MATERIAL (CURRENT LEVEL)

ITEM	PT/ASSY	DESCRIPTION	TYPE	QTY.
I	1304I	90° 18" SHWR ARM	PART	I

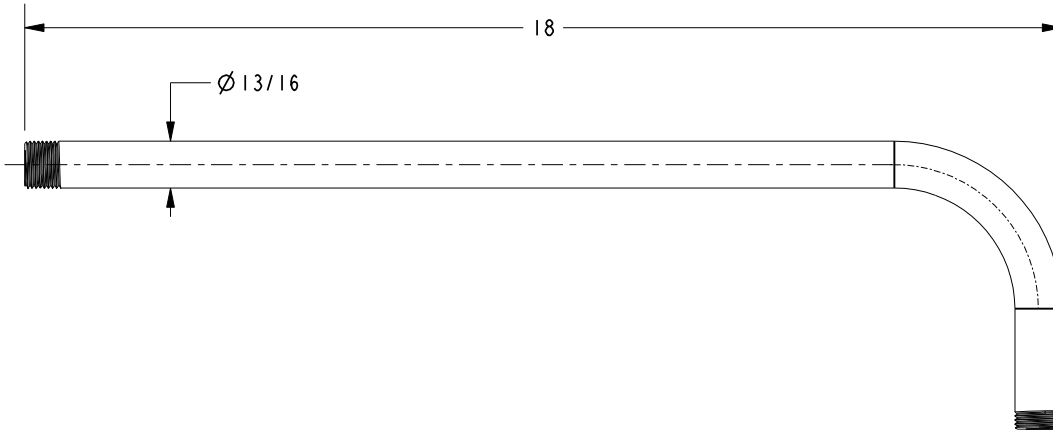
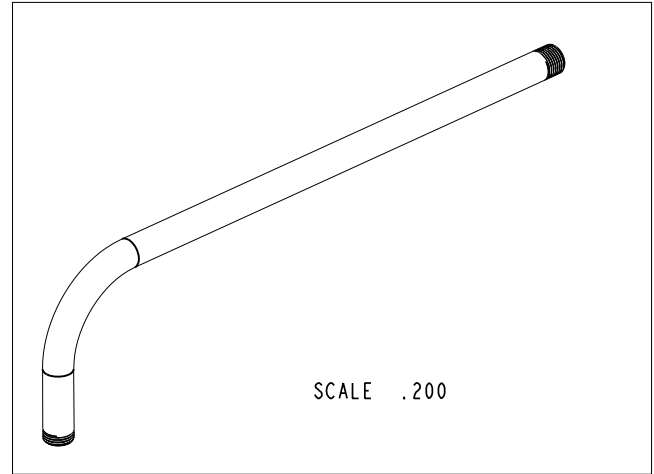

D

C

B

A

D

C

B

A

UNITS ARE: INCHES [MM]  
 TOLERANCES ARE:  
 FRACTIONS DECIMALS ANGLES  
 ±1/16" .X ±.1 [2.5] ±1°  
 .XX ±.06 [1.5]

(X.XXX) DENOTES CRITICAL DIMS.  
 ALL THREADS ARE CRITICAL

DRAWN C.GAYOSSO 08/14/18  
 CHECKED V.VU 08/14/18  
 APPROVED V.VU 08/14/18

**BRASSTECH** 2001 CARNEGIE AVE.  
 INCORPORATED SANTA ANA, CA 92705  
 (949) 417-5207

90° 18" SHWR ARM

DWG NO. 2021 REV B  
 SCALE .300 REF. - SHEET | OF |

COPYRIGHT 2005 BRASSTECH, INC.  
 THESE DRAWINGS AND THE DESIGNS  
 DEPICTED HEREIN ARE THE PROPRIETARY  
 PROPERTY OF BRASSTECH. ANY USE  
 OR REPRODUCTION IS SUBJECT TO  
 THE EXPRESS APPROVAL OF BRASSTECH.  
 UNAUTHORIZED USE IS STRICTLY  
 PROHIBITED. ALL RIGHTS RESERVED.

ZONE	REV	DESCRIPTION	DATE	APPROVED
-	B	EN-3552d	08/14/18	C.G.

TESTING	ASSEMBLY	PLATING	POLISHING	MACHINING	TOOLING FIXTURE #	APPLICATION
-	-	-	-	-		REMOVE ALL BURRS AND SHARP EDGES
						NEXT ASSY USED ON

4

3

2

1