

NOTES:

1. TO INSPECT ASSEMBLY, FOLLOW FIRST ARTICLE AND IN PROCESS INSPECTION SHEET.

- 2. APPLY LIGHT FILM OF SUPPER LUBE GREASE OR EQUIVALENT.
- 3. USE A 17 LB/IN TORQUE TO INSTALL.
- 4. APPLY LOCTITE 242.
- 5. APPLY ADHESIVE LOCTITE 680 OR EQUIVALENT.

BILL OF MATERIAL (CURRENT LEVEL)

ITEM	PT/ASSY	DESCRIPTION	TYPE	QTY.
1	11600	BODY SPRAY ESCUTCHEON	PART	1
2	11686	BODY SPRAY COLLAR	PART	1
3	50199	PIVOT BALL	PART	1
4	91160	WSHR, .5 ID X .74 OD X .25 THK, CONCAVED, RUBBER	PART	1
5	11687	BODY SPRAY BODY	PART	1
6	91019	O-RING, #2- 014, EPDM, 65-75 DURO, NSF 61	PART	1
7	11688	BODY SPRAY RETAINER	PART	1
8	91153	WSHR .438 X .738	PART	1
9	91073	O-RING, #2-120, EPDM, 65-75 DURO	PART	1
10	11599	FLOW REGULATOR, 1.75 GPM, LIGHT BLUE	PART	1
11	11689	BODY SPRAY FACE PLATE	PART	1
12	91432	O-RING, #2-016, PTFE, D55 DURO	PART	1
13	91520	JET SPRAY FACE PLATE	PART	1

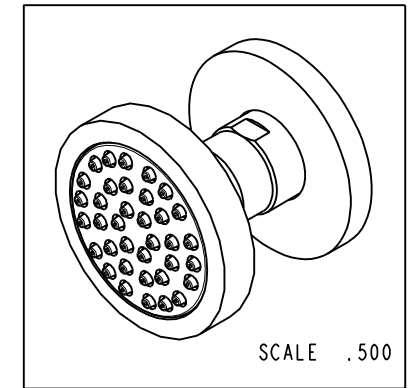
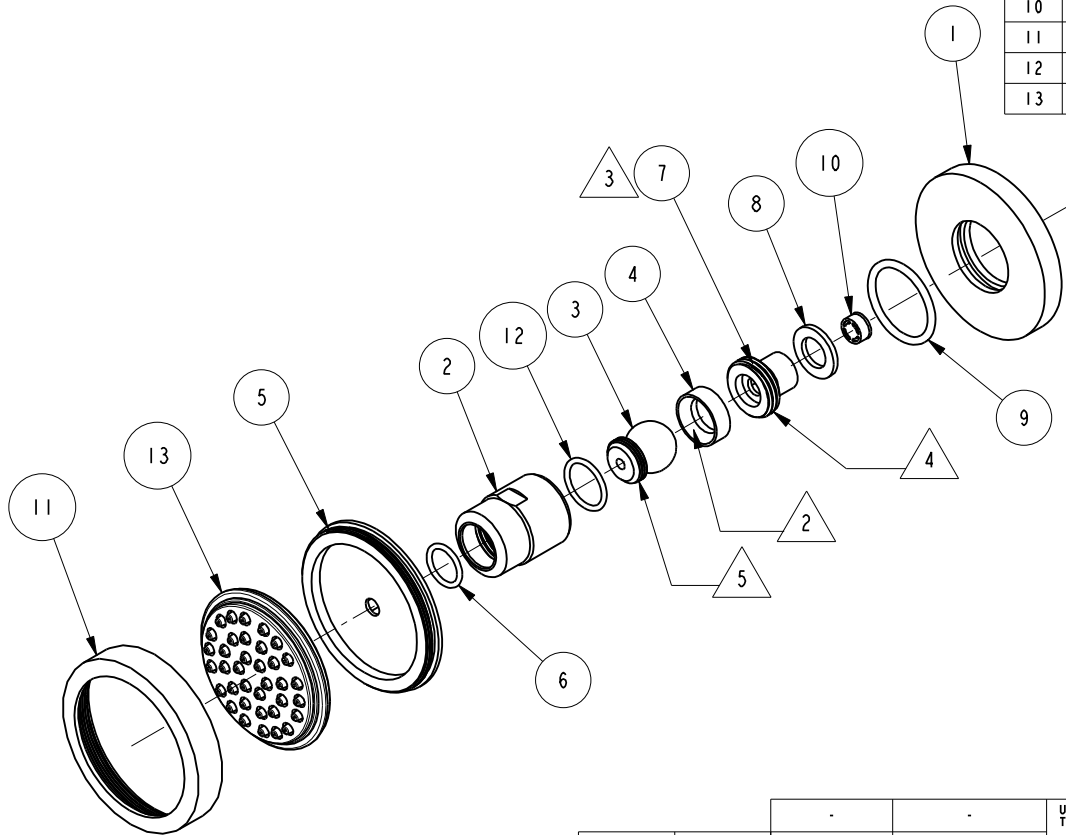

UNITS ARE: INCHES [MM]
 TOLERANCES ARE:
 FRACTIONS DECIMALS ANGLES
 ±1/16" .X ±.1 [2.5] ±°
 .XX ±.06 [1.5]

(X.XXX) DENOTES CRITICAL DIMS.
 ALL THREADS ARE CRITICAL

DRAWN JINSON 01/07/21
 CHECKED R.S. 01/07/21
 APPROVED R.S. 01/07/21

BRASSTECH 2001 CARNEGIE AVE.
 INCORPORATED SANTA ANA, CA 92705
 (949) 417-5207

SHOWER BODY SPRAY -
 CONTEMP.

DWG NO. 2174 REV B
 SCALE .400 REF. - SHEET 1 OF 2

ZONE	REV	DESCRIPTION	DATE	APPROVED
-	B	EN-4300d	01/07/21	R.S.
-	A	EN-2768	06/19/14	-
-	-	EN-1421	07/29/10	-

COPYRIGHT 2005 BRASSTECH, INC.
 THESE DRAWINGS AND THE DESIGNS
 DEPICTED HEREIN ARE THE PROPRIETARY
 PROPERTY OF BRASSTECH. ANY USE
 OR REPRODUCTION IS SUBJECT TO
 THE EXPRESS APPROVAL OF BRASSTECH.
 UNAUTHORIZED USE IS STRICTLY
 PROHIBITED. ALL RIGHTS RESERVED.

TESTING	ASSEMBLY	PLATING	POLISHING	MACHINING	TOOLING FIXTURE #	APPLICATION
-	-	-	-	-	-	REMOVE ALL BURRS AND SHARP EDGES
-	-	-	-	-	-	-
-	-	-	NEXT ASSY	USED ON	-	-

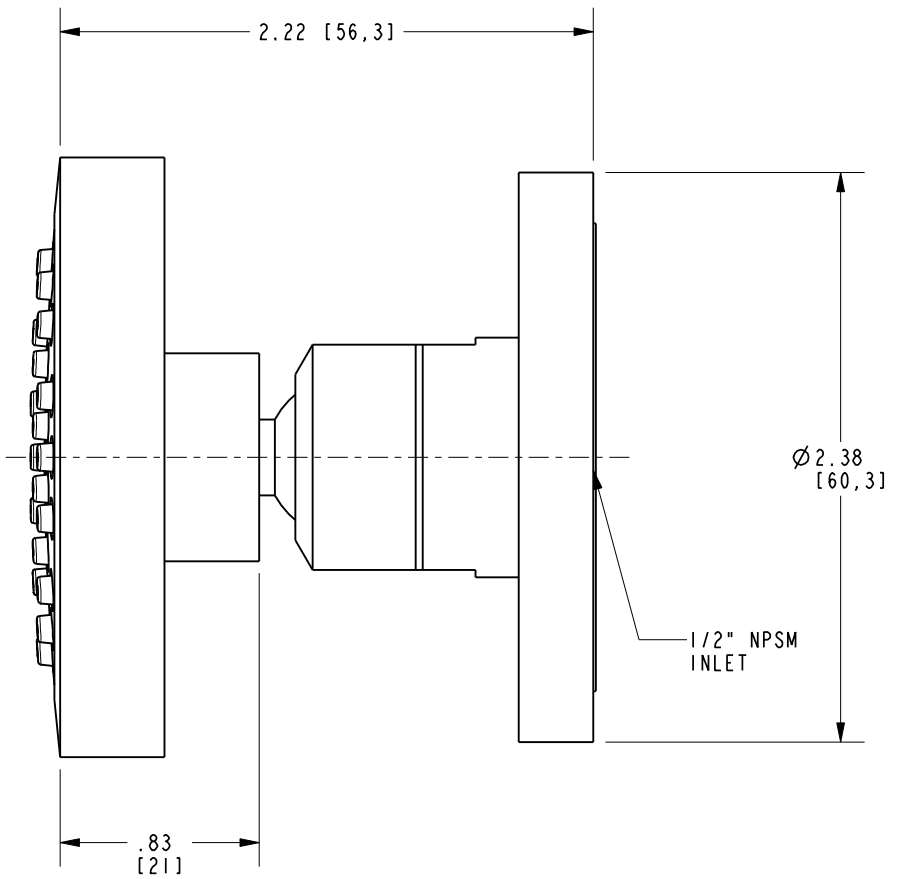
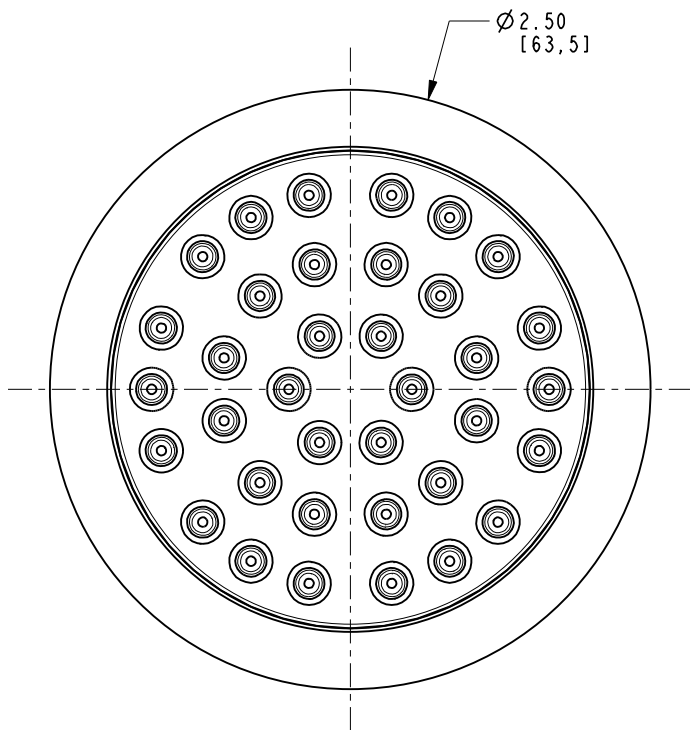

BRASSTECH

2001 CARNEGIE AVE.
SANTA ANA, CA 92705
(949) 417-5207

INCORPORATED		REV
DWG NO.	2174	B
SCALE 1.250	REF. -	SHEET 2 OF 2