

SPECIFICATIONS

DECORATIVE BOTTLE TRAP

Lavatory

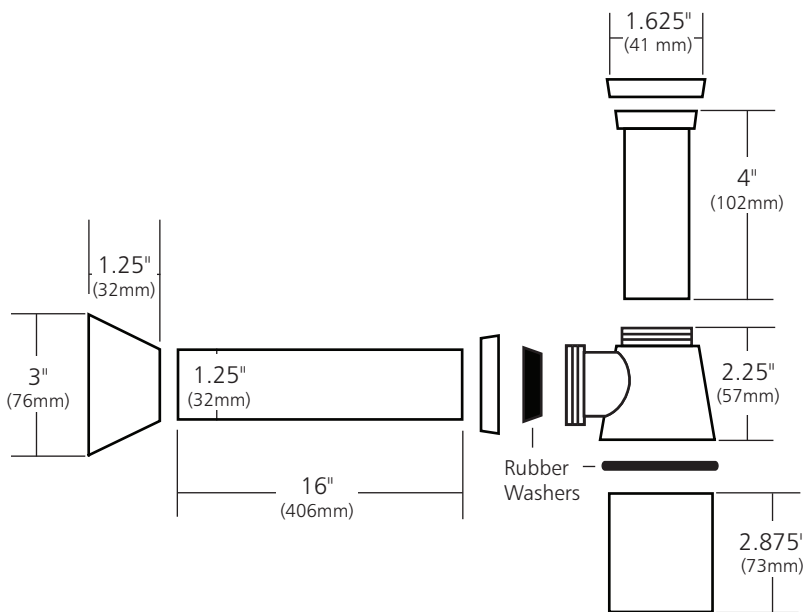
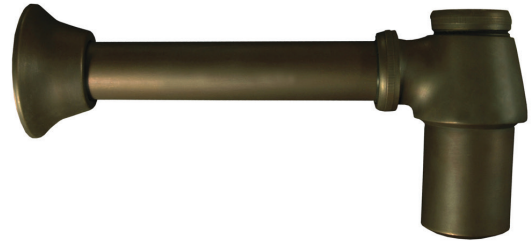

DR550-BN Brushed Nickel
 DR550-CH Chrome
 DR550-ORB Oil Rubbed Bronze

PRODUCT DETAILS

- Fully plated trap
- Perfect for exposed plumbing
- 16" (406mm) tail tube in heavy 17 gauge brass
- Features forged brass nut
- Includes Bell Flange