

MTI BASICS® Collection Tubs

MBCRFS6632

65.5" x 32" x 20"

Acrylic Freestanding Tub

Weight 130 lbs / 59 kg

Max Fill 70 gal to overflow

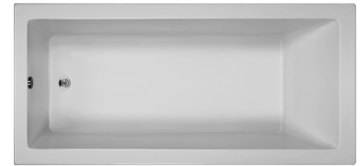

NOTE: Filling this tub to the maximum may require an above average size or dedicated water heater.

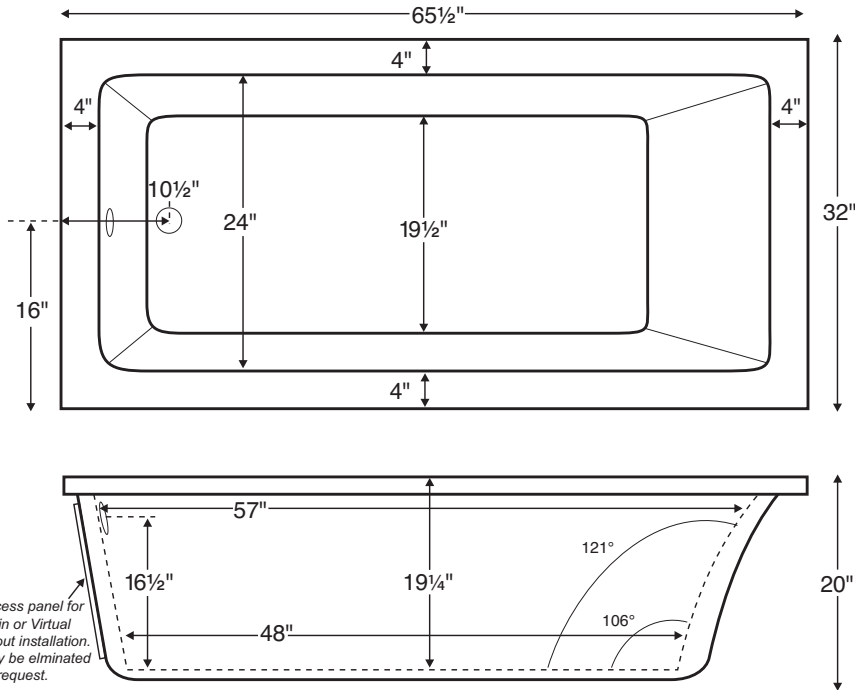

Soaker
Soaking bath - No jets. Includes pre-levleled foam base.
Part # MBSCRF6632

Soaker with Virtual Spout
Soaking bath - No jets. Includes Virtual Spout integrated high-flow tub filler (see important ordering information), pre-levleled foam base.
Part # MBSCRFS6632VS

Wilkins Dual Check Valve, model 700XL, ASSE® Listed 1024. CSA® Certified CSA B64.6)

Anti-siphon Cash Acme Vacuum Breaker ASSE1001/CSA B64.1.1

Options Must be ordered at time of purchase

- Standard White** (no charge)
- Color Upgrade:** Biscuit (MTISCOLOR)
- Quick Ship / Priority** Call for availability
- Soaker (QSHIPMTIS)

Accessories

- Lift and Turn Drain & Overflow**
- Chrome (MBWOC)
- White (MBWOW)
- Brushed Nickel (MBWOBN)
- Pillows**
- Soft Pillow
- White (MBPSW) Black (MBPSB)
- Roll-Up Pilow
- Light Aqua (MBPRUC) Black (MBRUB)



Access panel

Important Ordering and Installation Information

- Designed to install on a finished floor that is flat and level.
- Visible access panel is located behind the waste and overflow.
- Access panel dimensions vary according to tub model.
- May be ordered without access panel. Installation will be more difficult.
- The Virtual Spout is installed below the water level of the tub. Wilkins dual check valve and an Acme in-wall vent included. Some areas of the country require additional backflow prevention. Check local codes.
- Options listed cannot be combined with Designer Collection options.

• Before discarding tub crate, check for accessories that may be packaged inside.
 • All product measurements are ±1/2".
 • Specifications and configurations are subject to change without notice.
 • Measurements herein supersede all others published prior to publication date below.

