

28" x 23" x 13" / 10.5" deep

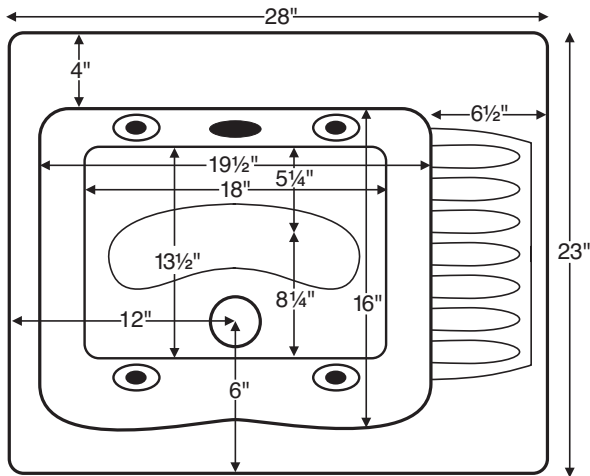

Side view of bottom of spa.

Before ordering or installing, please consider future access to equipment.

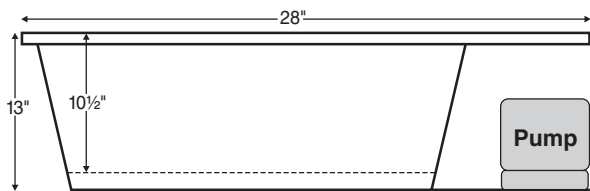

## ELECTRICAL SPECIFICATIONS

Required Electrical Service 1-15 amp, 110 Volt GFCI Outlet

## CONSTRUCTION AND STANDARD FEATURES

- Durable Lucite® cast acrylic shell is extremely scratch- and stain-resistant, yet renewable because the color goes all the way through the material.
- Non-porous surface makes cleaning easier.
- Reinforcement consisting of multi-layered backing of thick fiberglass / resin / titanium.
- 4 multi-directional point-massage jets (whirlpool models only).
- 1.0 bhp pump and 1 suction fitting (whirlpool models only).
- On / off control and silent air volume control (whirlpool models only).
- 2" drain.
- Acme in-wall atmospheric vent for backflow prevention included with Cleaning System. Access and spill pan will be required for proper maintenance of the device.
- Ergonomic design includes sloped floor, concave calf recesses and integrated raised stretch bar in the sink floor for foot exercises.
- CSA Certified C/US.
- Meets or exceeds ASTM D2565 and ANSI Z 124.6 1997.
- Limited Residential / Commercial Warranty: 1 year
- Shipping weight: 63 lbs.

### INSTALLATION:

Measurements are  $\pm 1/2"$  and are subject to change without notice. Data herein supersedes all previous prior to publication date indicated below.

Effective 082119

Designer Collection Foot Spas

# Foot Spa 1

Part # - MTL-110JP



### Soaker (non-jetted)

AVAILABLE COLORS - White - Part # MTL110JPSW \$650

Bone, Biscuit - Part # MTL110JPB \$670

Black, Sterling Silver - Part # MTL110JPGRP1 \$740

### Whirlpool (without cleaning system)

AVAILABLE COLORS - White - Part # MTL110JPW \$1,420

Bone, Biscuit - Part # MTL110JPB \$1,435

Black, Sterling Silver - Part # MTL110JPGRP1 \$1,500

### Whirlpool with Cleaning System

AVAILABLE COLORS - White - Part # MTL110JPCLW \$2,195

Bone, Biscuit - Part # MTL110JPCLB \$2,210

Black, Sterling Silver - Part # MTL110JPCLGRP1 \$2,280

### Whirlpool with Cleaning System & Factory-Supplied Valves

AVAILABLE COLORS - White - Part # MTL110JPCLVW \$2,470

Bone, Biscuit - Part # MTL110JPCLVB \$2,490

Black, Sterling Silver - Part # MTL110JPCLVGRP1 \$2,550

### OPTIONS

Drain Kit - Cable Driven

Chrome (JPKC) \$195, Brushed Nickel (JPKBRN) \$235

Ozonator Sanitation System (OZONE) \$535

Fresh Wave Cleaning Solution - see information at bottom of page.

Pack of 3 (FFCLBOT) \$110, Case of 12 (FFCLCASE) \$295

Quick Ship/ Priority. Call for availability. Part # QUISINKSH \$190

### Fresh Wave

*Fresh Wave* is a detergent specially formulated to clean the internal plumbing components of *any whirlpool*, including *Jentle Ped*® foot spa. This cleaning solution has been thoroughly tested and is not harmful to any components, including seals.



©2019 by MTI Baths, Inc. Modification Rights Reserved.