

Harvest

Part # - MTPS-109

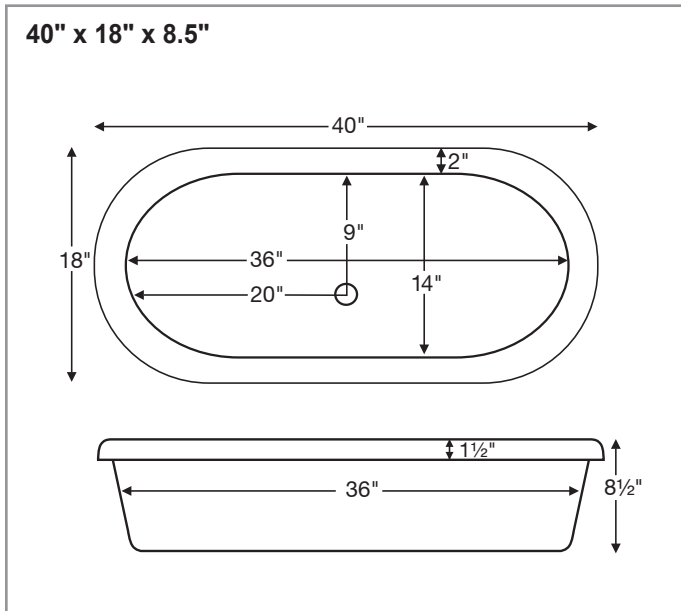

AVAILABLE COLORS

White - Part # MTPS109W \$545

Bone, Biscuit - Part # MTPS109B* \$565

Black, Sterling Silver - Part # MTPS109GRP1* \$735

**Must specify color on order*

OPTIONS

Quick Ship / Priority. *Call for availability.* Part # QUISINKSH \$175

Shipping Weight: 25 lbs

NOTES: Due to the particular shape of this sink, MTI recommends having the product on site before attempting any cut-out in counter top material. Measurements are $\pm 1/2"$ and are subject to change without notice. Data herein supersedes all previous prior to publication date indicated below.

CONSTRUCTION AND STANDARD FEATURES

- Single-bowl design; 3.5" drain opening pre-drilled.
- Can be caulked directly to the countertop without the use of clips or channels.
- No holes can be drilled for Harvest sink.
- Durable Lucite® cast acrylic shell is extremely scratch- and stain-resistant yet renewable because the color goes all the way through the material.
- Non-porous surface makes cleaning and sanitizing faster and more effective.
- Multi-layered reinforced backing of thick fiberglass / resin / titanium.
- At least 30% thicker and stronger than other makes.
- 2-year limited residential and commercial warranty.