

CONSTRUCTION AND STANDARD FEATURES

- Dual-bowl design; 3.5" drain openings pre-drilled.
- Can be undermounted or caulked directly to the countertop without the use of clips or channels.
- No holes drilled standard; up to 4 holes drilled by MTI at no additional charge.
- Durable Lucite® cast acrylic shell is extremely scratch- and stain-resistant yet renewable because the color goes all the way through the material.
- Non-porous surface makes cleaning and sanitizing faster and more effective.
- Multi-layered reinforced backing of thick fiberglass / resin / titanium.
- Up to 30% thicker and stronger than other makes.
- 1-year limited residential and commercial warranty.

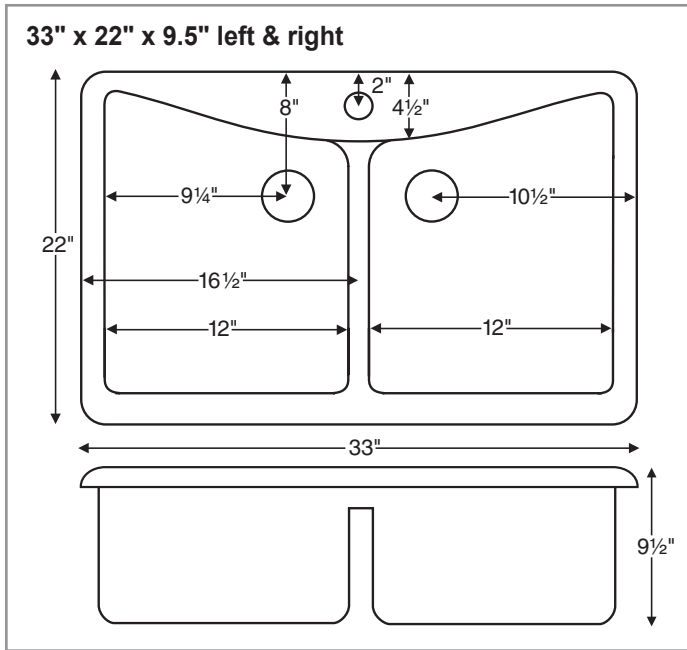

MBKS80

AVAILABLE COLORS

- White - Part # MBKS80W
- Bone, Biscuit - Part # MBKS80B
- Black, Sterling Silver - Part # MBKS80GRP1

OPTIONS

Quick Ship/Priority. Call for availability. - Part #: QUINSINKSH
Shipping Weight: 24 lbs

NOTES: Measurements are ±1/2" and are subject to change without notice. Data herein supersedes all previous prior to publication date indicated below.