

MONOGRAM 36" ALL-GAS PROFESSIONAL RANGE WITH 4 BURNERS AND GRIDDLE

ZGP364NDRSS (NATURAL GAS)
ZGP364LDRSS (LIQUID PROPANE)

DIMENSIONS AND INSTALLATION INFORMATION (IN INCHES)

Professional ranges offer a number of choices in size and cooktop configurations.

All Professional Ranges are factory set for natural or liquid propane gas. The correct model should be ordered for the installation situation.

NOTE

Conversion kits are included with the range if the wrong gas type was ordered. High Altitude kit, WB28K10553 for operation above 6,000 feet (for Natural and LP gas models), is also available. The kits must be installed by a qualified service technician at additional cost.

INSTALLATION INFORMATION

Before installing, consult installation instructions packed with product or online at Monogram.com for current dimensional data.

A suitable 36" or wider vent hood is required for installation over ranges with a grill and recommended for all other ranges.

ADVANCE PLANNING

Refer to dimensional drawings for appropriate placement and necessary clearances when planning the installation.

- Working areas adjacent to the range should have 18" minimum clearance between countertop and cabinet bottom.
- Clearance between range and side wall or combustible material must be at least 12" on each side.
- Installation must conform with local codes. In the absence of local codes, the range must comply with the National Fuel Gas Code, ANSI Z223.1-1990.

⚠ WARNING

Installations without a hood require 48" minimum to combustibles. A custom hood installation with exposed horizontal combustible surfaces must have an Auto-On feature. Refer to hood installation instructions for specific hood clearances.

The surface of the entire back wall above the range and below the hood must be covered with a non-combustible material such as metal, ceramic tile, brick, marble or other stone.

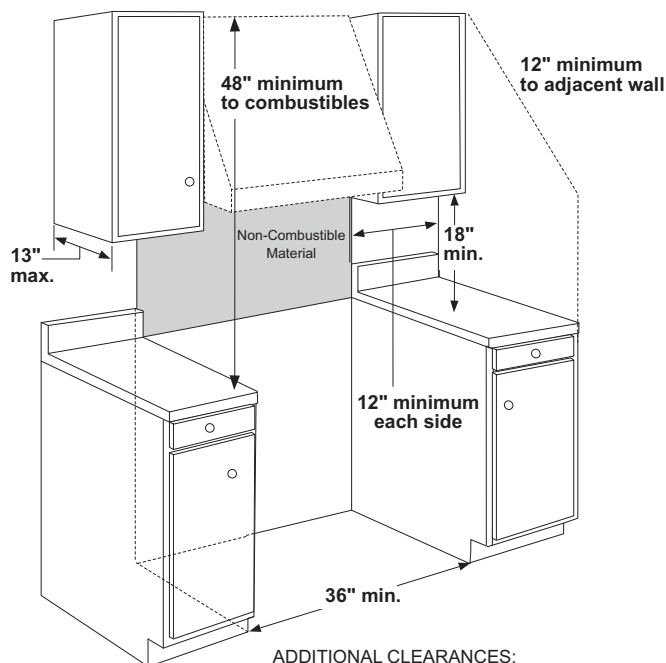
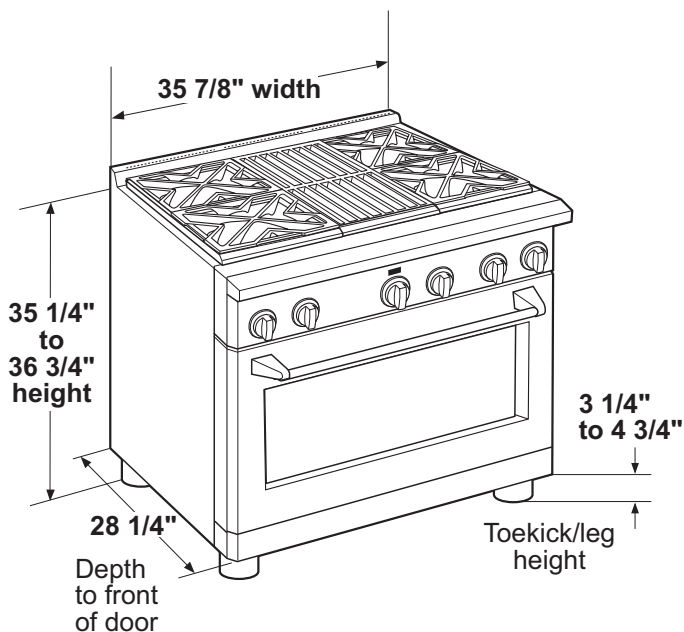

ADDITIONAL CLEARANCES:

Allow 12" minimum clearance to an adjacent wall on each side.

Working areas adjacent to the range top should have 18" minimum clearance between countertop and the bottom of the wall cabinet.

ELEVATE EVERYTHING™

MONOGRAM



MONOGRAM 36" ALL-GAS PROFESSIONAL RANGE WITH 4 BURNERS AND GRIDDLE

ZGP364NDRSS (NATURAL GAS)
ZGP364LDRSS (LIQUID PROPANE)

DIMENSIONS AND INSTALLATION INFORMATION (IN INCHES)

ELECTRICAL REQUIREMENTS

Ranges must be hooked up to a 120V, 60Hz properly grounded dedicated circuit protected by a 15-amp circuit breaker or time-delay fuse.

UNIVERSAL UTILITY LOCATIONS

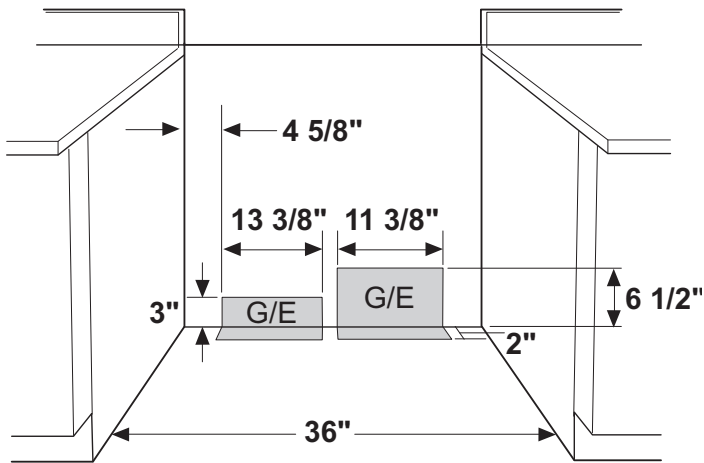

Locate gas and electric as shown

GAS SUPPLY

- The natural gas models are designed to operate at 5" water column pressure. For proper operation, the pressure of the natural gas supplied to the regulator must be between 7" and 13" water column.
- The LP models are designed to operate at 10" water column pressure. For proper operation, the pressure of the LP gas supplied to the regulator must be between 11" and 13" water column.

OPTIONAL BACKSPLASH ACCESSORIES

The range requires a 12" minimum clearance to a vertical combustible surface at the rear. A backsplash is required for installations with less than 12" clearance. The following backsplash accessories are available, or a custom, non-combustible backsplash can be used.

ORDER ONE WITH A 36"-WIDE RANGE BACKSPLASH

UX12B36PSS-12" backsplash

UXADJB36PSS-30"-36" adjustable-height backsplash with warming shelf

SIDE VIEW WITH A BACKSPLASH

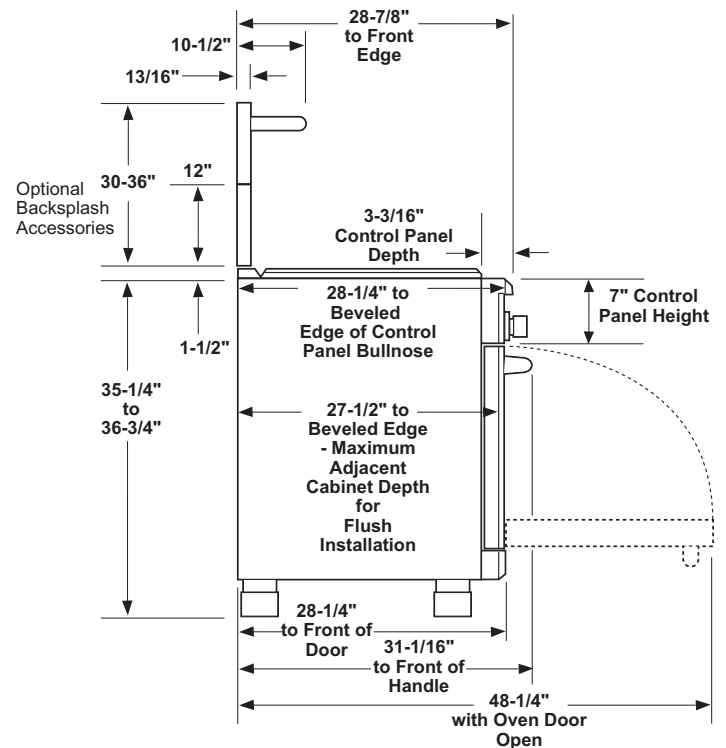

ELEVATE EVERYTHING™

MONOGRAM



Listed by
Underwriters
Laboratories



Product Specification Revised 10/18

MONOGRAM 36" ALL-GAS PROFESSIONAL RANGE WITH 4 BURNERS AND GRIDDLE

ZGP364NDRSS (NATURAL GAS)
ZGP364LDRSS (LIQUID PROPANE)

FEATURES AND BENEFITS

AUTHENTIC PROFESSIONAL APPEARANCE

Stainless steel with smoothly finished edges, large electronic control knobs and heavy duty handles

SEALED, DUAL-FLAME STACKED BURNERS

Deliver a full spectrum of heat settings, from an ultra-low 140°F simmer to an intense 18,000 BTUs*

LARGEST ALL-GAS PROFESSIONAL OVEN CAPACITY

MONOGRAM PROFESSIONAL DUAL-BURNER BAKE SYSTEM

Combines Reverse-Air convection technology with an infrared broil and gas burner to provide superb baking results, with fast preheating

INFRARED BROIL BURNER

Produces intense heat needed to sear meats to lock in juices and is thermostatically controlled to provide top browning when baking or convection baking

HEAVY-DUTY OVEN RACKS

Glide smoothly in and out on stainless steel ball bearings for easy access, and are designed to remain in the oven during the self-clean cycle

LED TASK LIGHTS

Below the bullnose, provide a functional and theatrical touch

STAINLESS STEEL AND ALUMINUM-CLAD GRIDDLE

Offers 18,000 BTUs* of cooking power, allowing fast and consistent heating across the entire cooking surface

ELECTRONIC IGNITION WITH AUTOMATIC REIGNITION

Ensures a continuous flame and reignites automatically if accidentally extinguished

REVERSIBLE BURNER GRATES

Flat on one side and uniquely contoured on the other to accommodate round-bottom woks

MODEL ZGP364NDRSS - Natural Gas

MODEL ZGP364LDRSS - Liquid Propane

*Natural Gas Model



ELEVATE EVERYTHING™

MONOGRAM

Product Specification Revised 10/18