

### INSTALLATION INSTRUCTIONS 30°, 60°, and 90° downward deflector hoods and vertical air deflector blades models HD/HDB, HDS/HDC, PTC, PTS/BTS

#### ACCESSORY DOWNWARD DEFLECTOR HOOD

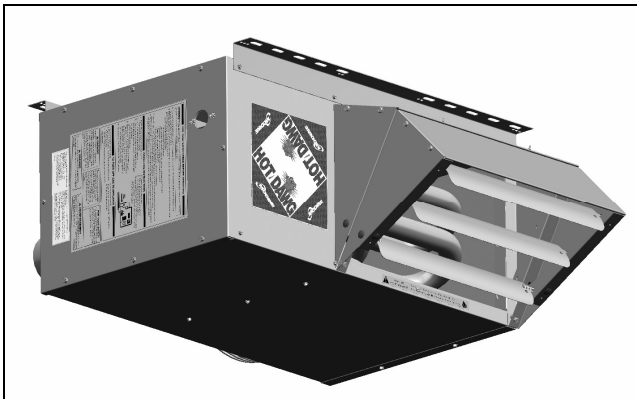

#### VERTICAL AIR DEFLECTOR BLADES

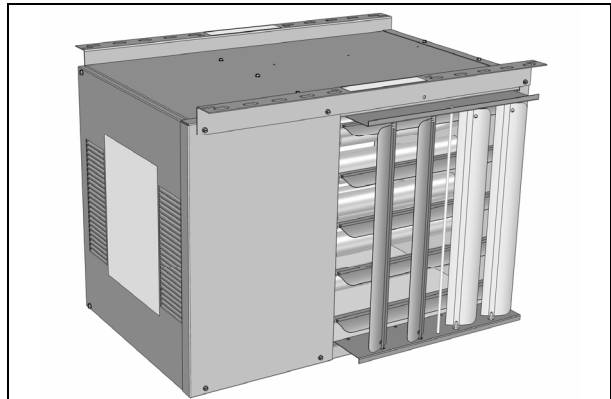

### WARNING

Gas supply shall be shut-off and the electrical power disconnected before proceeding with the conversion. Failure to do so could result in fire, explosion, electrical shock, or the unit starting suddenly resulting in injury.

### TABLE OF CONTENTS

Instructions – Downward Deflector Hood.....	2-3
Instructions – Vertical Air Deflector Blades.....	4

### IMPORTANT

1. The use of this manual is specifically intended for a qualified installation and service agency. All installation and service of these kits must be performed by a qualified installation and service agency.
2. These instructions must also be used in conjunction with the Installation and Service Manual originally shipped with the appliance, in addition to any other accompanying component supplier literature.

# INSTALLATION – DOWNWARD DEFLECTOR HOOD

## Deflector Hood Model Application

The 30°, 60° and 90°, Downward Deflector Hoods are designed for use installed propeller and blower unit heaters.

## Assembly/Installation

The recommended procedure for assembly and installation is described as follows:

1. Before beginning installation of the accessory hood, remove all of the spring loaded louver blades from the unit heater on which the hood is to be installed. For model sizes 30-155, these blades (except for one) will be relocated in the face of the hood assembly after the hood is attached to the unit heater. To remove the spring loaded louver blades, grasp the blade and apply pressure against the louver blade retaining spring. After compressing the spring, the tab on the opposite side of the blade can be removed from the unit, freeing the blade from the unit.

**Note:** Do not to lose the louver blade retaining springs as they will be required later to install the blades into the hood assembly.

2. Remove the screw on the right lower face of the unit (when facing the unit air outlet) and attach the hood right side panel onto the unit with unit screw previously removed by screwing through the existing hole.

Figure 2.1 - Hood Exploded View

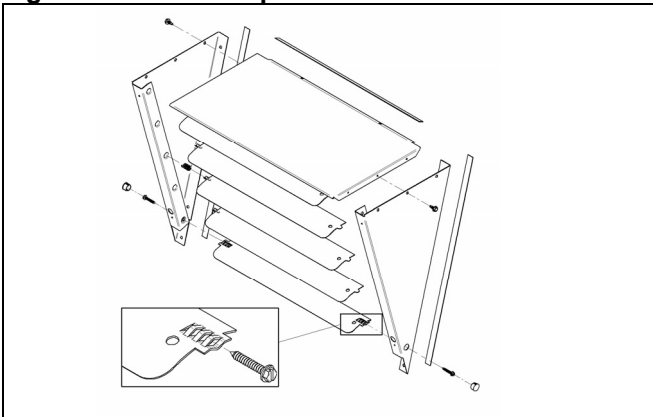
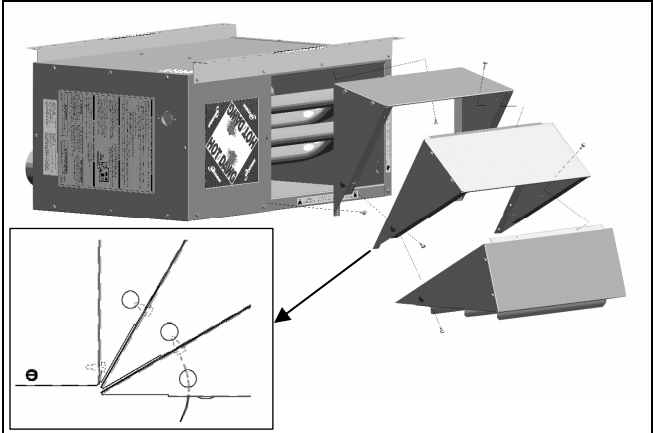
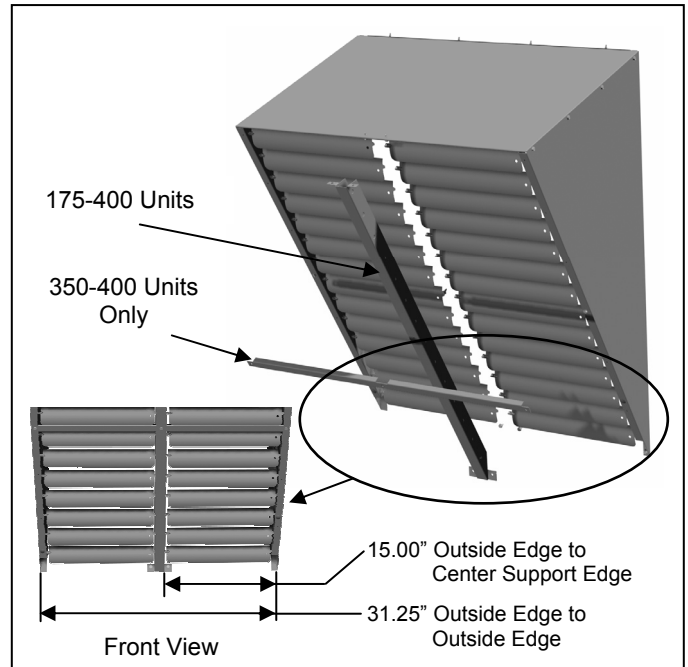

Figure 2.2 - Hood to Unit Exploded View



3. Insert the hood top panel into the top of the unit air outlet opening (hemmed edge toward the hood outlet, bent edge toward the unit) with the right side panel on the outside of hood right top flange (see Figure 2.1). Fasten the panels with the #10 x 1/2" self-drilling screws provided.
4. Attach the hood top to the flange inside the air outlet of the unit with the #10 x 1/2" self drilling screws provided, through the holes in the hood top.
5. Mount the left side hood panel to the hood top with the screws provided but do not fasten to the unit casing at this time. Be sure to mount the left side on the outside of the hood top flanges.
6. Model sizes 175-400 require the installation of a vertical deflector blade bracket and model sizes 350 and 400 require a horizontal deflector blade bracket cross member be installed. These are shown in Figure 2.3.

Figure 2.3 – Deflector Bracket and Cross Member



7. In each hood assembly kit for model sizes 30-155 is a fixed deflector louver blade with serrated tabs at each end to accept fastening screws (see Figure 2.1). Install the blade between the outermost hood sides in the bottom deflector blade position and fasten in place with #8 x 1" screws provided through the holes in the sides of the hood and tightening. Locate the blade with the curved surface up and the rounded corners toward the outlet of the hood. Rotate the deflector to direct the air flow in the desired direction, typically perpendicular to the hood outlet face.
8. Fasten the lower corner of the left side hood to the unit face with a self drilling screw. For unit sizes 175-400, ensure that the assembly is square on the opening and the dimension from the outside edges and to the center support match those shown in Figure 2.3.

## INSTALLATION – DOWNWARD DEFLECTOR HOOD

9. If 60° or 90° hoods are being assembled, it is necessary to connect two 30° sections together for a 60° hood, and three 30° sections for a 90° hood. See Figure 2.2.
  - a. For hoods with multiple sections, connect the sections together by attaching the left and right side panels to the front of the previous section using the upper and middle mounting holes on the side plates with #10 x 1/2" self drilling screws.
  - b. Install the hood top between the side panels with the hemmed edge toward the hood outlet (deflector blades). Fasten with #10 x 1/2" self drilling screws provided.
  - c. Install two or more #10 x 1/2" self drilling screws through the top panel of the first hood and into the top of the second hood top panel where they overlap. Locate the screws 5" in from each side of the hood and 1/4" back from the seam of the two top panels.
  - d. For model sizes 30-155, one fixed blade is supplied with each kit. Extra fixed blades should be discarded and only the fixed louver blade from the first 30° section kit be used (refer to Step 7).
10. For model sizes 30-155, place the louvers removed from the unit heater in Step 1 into the outlet of the downward deflector hood. For model sizes 175-400, the deflector hood kit includes short louver blades and additional louver retaining springs that are to be installed into the outlet of the hood. The original longer blades that were removed from the unit can be saved for future use or recycled. To install the spring loaded louver blades, place the louver blade retaining spring over the left end tab of the blade and guide the spring into the recessed dimple in the left side panel of the hood. Apply pressure to compress the spring and then insert the metal tab on the opposite end of the blade into the tab clearance holes in the right hand side panel of the hood. Repeat this procedure for all of the louver blades (see Figure 2.1). Rotate the blades in the desired direction of air flow. Do not operate the unit with the blades in the closed position.
11. Attach the included warning label to the lower front of the discharge hood.
12. Install the screw hole filler plugs to all remaining open exterior holes.

# INSTALLATION – VERTICAL DEFLECTOR BLADES

## Vertical Deflector Blade Model Application

The Vertical Deflector Blades are designed for use with propeller and blower unit heaters. Installation of the assembly is easiest prior to unit installation.

## Assembly/Installation

The following section contains the recommended procedure for assembly and installation of the vertical louver blade assembly. Note that model sizes 30-155 feature a single bank of louvers. Due to the larger discharge opening area, model sizes 175-200 feature two louver banks and sizes 250-400 feature four louver banks (refer to Figure 4.3). As a result, the instructions below need to be repeated for each louver bank on unit sizes 175 and larger.

1. Before beginning installation of the accessory vertical louver blade assembly, remove the top and bottom spring loaded louver blades from the unit heater on which the vertical louvers are to be installed. This is to allow working room for attaching the top and bottom vertical louver brackets. These blades will be replaced after the brackets are installed. To remove the spring loaded louver blades, grasp the blade and apply pressure against the blade retaining spring. After compressing the spring, the tab on the opposite side of the blade can be removed from the unit.  
**Note:** Do not lose the louver blade retaining springs as they will be required later to reinstall the blades.
2. Place one of the vertical louver mounting brackets on the bottom edge of the unit discharge opening so that the flanges of the bracket are facing down with one flange on the inside edge of the bottom panel on the unit heater (see detailed view in Figure 4.2). Attach with #10 x ½" screws supplied with the kit.
3. Repeat the process outlined in Step 2 for the top vertical louver mounting bracket except note that the flanges of the bracket should face upward (see Figure 4.2).
4. Replace the two louvers removed from the unit heater in Step 1. To install the spring loaded louver blades, place the louver blade retaining spring over the left end tab of the blade and guide the spring into the recessed dimple in the left side panel of the heater. Apply pressure to compress the spring and then insert the metal tab on the opposite end of the blade into the tab clearance holes in the right hand side panel of the heater. Rotate the horizontal blades in the desired direction of air flow. Do not operate unit with the blades in the closed position.
5. Insert the vertical louver bracket support rod through the holes provided in the mounting flanges. Secure this support rod with the acorn push nuts provided.
6. Install the vertical louver blades into the top and bottom brackets, using the same process as outlined in Step 4.
7. Adjust deflector blades to obtain desired direction of heat throw. Do not operate the unit with the blades in the closed position.

Figure 4.1 – Vertical Blades Exploded View



Figure 4.2 – Vertical Louver to Unit Installation

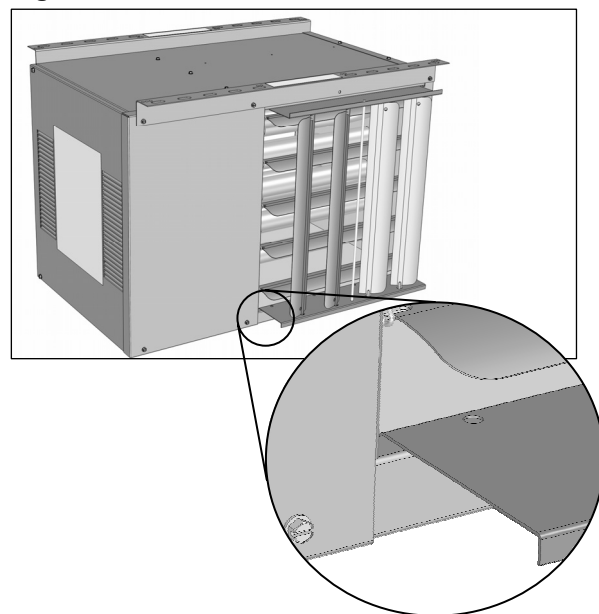
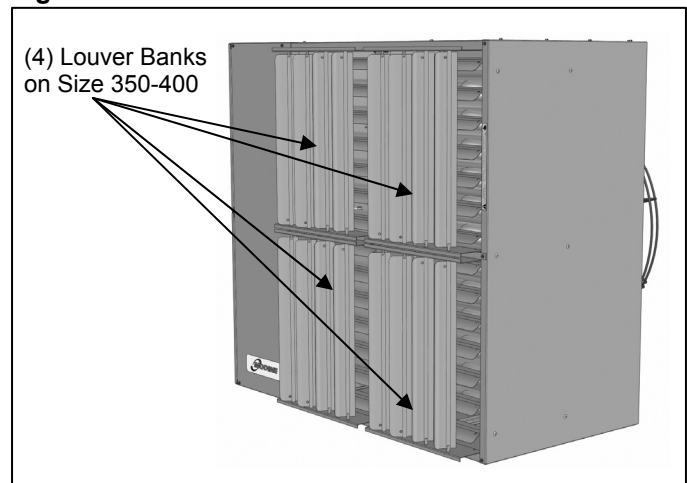

Figure 4.3 – Vertical Louvers after Installation



Modine Manufacturing Company has a continuous product improvement program, and therefore reserves the right to change design and specifications without notice.