

MLZ-KP12NA2 12,000 BTU/H EZ FIT CEILING CASSETTE



Job Name:

System Reference:

Date:



GENERAL FEATURES

- Fits between 16" joists spacing
- Stylish, square design panel
- Built-in condensate lift mechanism (19.6")
- Serviceable from the bottom (electrical and flare connections)
- Adjustable fan speeds and vane directions
- Washable antibacterial and deodorizing filter
- Multiple control options available:
 - Hand-held Remote Controller (provided with unit)
 - kumo cloud® smart device app for remote access
 - Third-party interface options
 - Wired or wireless controllers
- Pocket inside the access panel for kumo cloud® Wireless Interface

Specifications		System	
Unit Type		MLZ-KP12NA2	
Cooling Capacity ^{1,3}		BTU/H	12,000
Heating Capacity ^{2,3}		BTU/H	15,400
Electrical	Voltage, Phase, Frequency		208/230, 1, 60
	Guaranteed Voltage Range	V AC	187- 253V
	Voltage: Indoor - Outdoor, S1-S2	V AC	208/230
	Voltage: Indoor - Outdoor, S2-S3	V DC	24
	Short-circuit Current Rating [SCCR]	kA	5
Indoor Unit	MCA	A	1.0
	Fan Motor Full Load Amperage	A	0.68
	Airflow Rate at Cooling, Dry	CFM	212–272–297–332
	Airflow Rate at Cooling, Wet	CFM	180–219–252–282
	Airflow Rate at Heating, Dry	CFM	212–272–311–350
	Sound Pressure Level [Cooling]	dB[A]	27–32–36–40
	Sound Pressure Level [Heating]	dB[A]	26–32–36–40
	Drain Pipe Size	In. [mm]	1-1/4 [32]
	Condensate Lift Mechanism, Maximum Distance	In. [mm]	19-11/16 [500]
	Coating on Heat Exchanger		—
	External Finish Color		Munsell 4.0GY 9.1/0.2
	Unit Dimensions	W x D x H: In. [mm]	43-3/8 x 14-3/16 x 7-5/16 [1,102 x 360 x 185]
	Package Dimensions	W x D x H: In. [mm]	46-5/16 x 15-3/4 x 11-1/8 [1,177 x 400 x 284]
	Unit Weight	Lbs. [kg]	34 [15.5]
Package Weight	Lbs. [kg]	41 [19.0]	
Refrigerant	Type		R410A
Piping	Gas Pipe Size O.D. [Flared]	In.[mm]	3/8 [9.52]
	Liquid Pipe Size O.D. [Flared]	In.[mm]	1/4 [6.35]

NOTES:

Conditions

¹Cooling (Indoor // Outdoor) °F 80 DB, 67 WB // 95 DB, 75 WB
²Heating at 47°F (Indoor // Outdoor) °F 70 DB, 60 WB // 47 DB, 43 WB

³Capacity varies based on the number of indoor units operating and the model of the Multi-zone Outdoor Unit. For reference to connected capacity charts, please refer Multi-zone Outdoor Unit Operational Performance.:

INDOOR UNIT ACCESSORIES: MLZ-KP12NA2

Control Interface	BACnet® and Modbus® Interface	PAC-UKPRC001-CN-1
	CN24 Relay Kit	CN24RELAY-KIT-CM3
	IT Extender	PAC-WHS01IE-E
	kumo station® for kumo cloud®	PAC-WHS01HC-E
	Lockdown bracket for remote controller	RCMKP1CB
	System Control Interface	MAC-334IF-E
	Thermostat Interface	PAC-US444CN-1
	Thermostat Interface	PAC-US445CN-1
	USNAP Adapter	PAC-WHS01UP-E
	Wireless Interface for kumo cloud®	PAC-USWHS002-WF-2
Remote Sensor	Wired Remote Sensor	M21EAA307
	Wireless temperature and humidity sensor for kumo cloud®	PAC-USWHS003-TH-1
Wired Remote Controller	Deluxe Wired MA Remote Controller†	PAR-40MAAU
	Simple MA Remote Controller†	PAC-YT53CRAU-J
	Touch MA Controller†	PAR-CT01MAU-SB
Wireless Remote Controller	kumo touch™ RedLINK™ Wireless Controller	MHK2
Condensate	Blue Diamond (Advanced) Mini Condensate Pump w/ Reservoir & Sensor (208/230V) [recommended]	X87-721
	Blue Diamond (MicroBlue) Mini Condensate Pump (110/208/230V) up to 18,000 BTU/H	X86-003
	Refco Condensate Pump (100-240 VAC) up to 120,000 BTU/H	COMBI
Disconnect Switch	(30A/600V/UL) [fits 2" X 4" utility box] - Black	TAZ-MS303
	(30A/600V/UL) [fits 2" X 4" utility box] - White	TAZ-MS303W
Filter	Anti-allergy Enzyme Filter	MAC-408FT-E
Grille	Grille (required)	MLP-444WU
Lineset	15' x 1/4" x 15' / 3/8" Lineset (Twin-Tube Insulation)	MLS143812T-15
	30' x 1/4" x 30' / 3/8" Lineset (Twin-Tube Insulation)	MLS143812T-30
	50' x 1/4" x 50' / 3/8" Lineset (Twin-Tube Insulation)	MLS143812T-50
	65' x 1/4" x 65' / 3/8" Lineset (Twin-Tube Insulation)	MLS143812T-65

NOTES:

†Requires MAC-334IF-E

- M-Series EZ FIT® Recessed Ceiling Cassette, Floor-mount and Wall-mount
Allows indoor units to connect to an MA Controller:
 - Deluxe MA Remote Controller
 - Simple MA Controller
 - Touch MA Controller

INDOOR UNIT DIMENSIONS: MLZ-KP12NA2

Unit: inch

INDOOR UNIT OUTLINE DRAWING

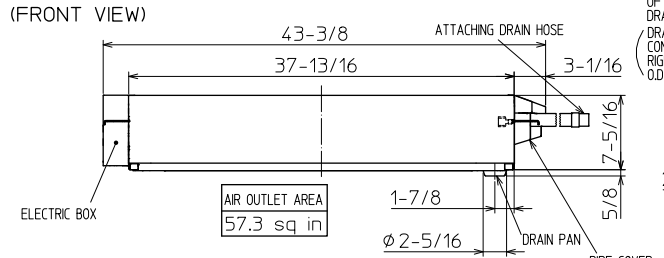
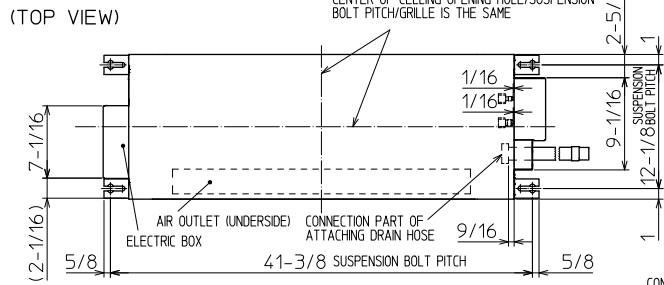

REMOTE CONTROLLER OUTLINE DRAWING

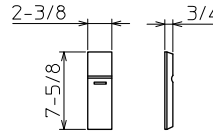

(RIGHT SIDE VIEW)

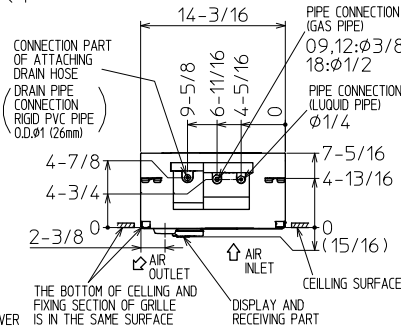

GRILLE OUTLINE DRAWING (MLP-444W)

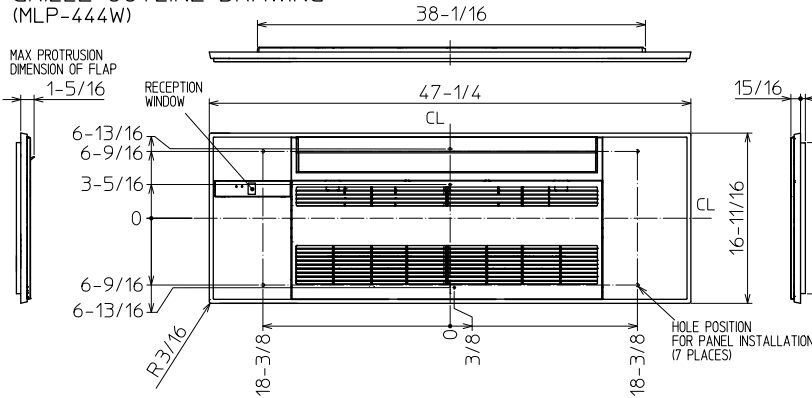

		KP09/12NA	KP18NA
EXTENSION PIPE	LIQUID PIPE O.D.	Ø1/4	
	GAS PIPE O.D.	Ø3/8	Ø1/2
CONNECTION OF PIPE	LIQUID PIPE	FLARED CONNECTION Ø1/4	
	GAS PIPE	FLARED CONNECTION Ø3/8	FLARED CONNECTION Ø1/2
DRAIN HOSE	HEAT INSULATOR O.D.	CONNECTION I.D.	EFFECTIVE LENGTH
DRAIN PIPE CONNECTION	Ø1-1/4	Ø1	18-7/8
		RIGID PVC PIPE O.D. Ø1 (26mm)	

NOTE1. CUT THE DRAIN HOSE (ACCESSORY) FOR USE, IF NECESSARY.

INDOOR UNIT DETAIL VIEW (TOP VIEW)

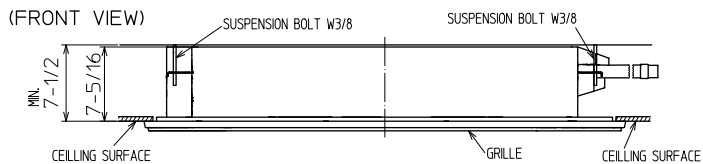
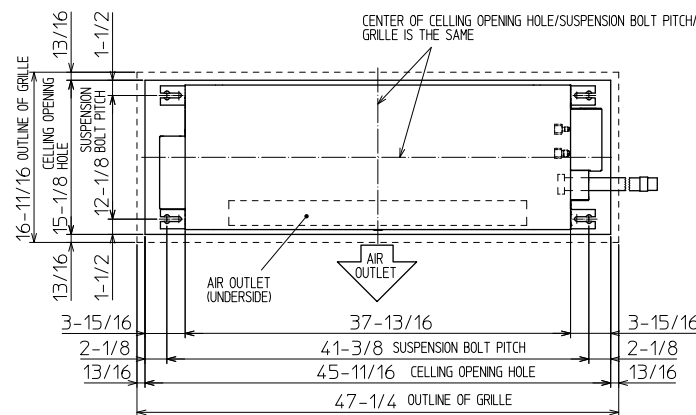

THE METHOD FOR STANDING DRAIN FROM INDOOR UNIT
* CUT THE DRAIN HOSE (ACCESSORY) FOR USE, IF NECESSARY.

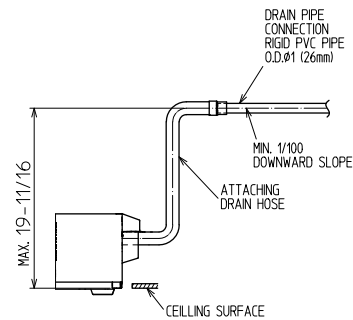

1340 Satellite Boulevard Suwanee, GA 30024
Toll Free: 800-433-4822 www.mehvac.com

FORM# MLZ-KP12NA2-U1 - 202209



MLZ-KP18NA2 18,000 BTU/H EZ FIT CEILING CASSETTE



Job Name:

System Reference:

Date:



GENERAL FEATURES

- Fits between 16" joists spacing
- Stylish, square design panel
- Built-in condensate lift mechanism (19.6")
- Serviceable from the bottom (electrical and flare connections)
- Adjustable fan speeds and vane directions
- Washable antibacterial and deodorizing filter
- Multiple control options available:
 - Hand-held Remote Controller (provided with unit)
 - kumo cloud® smart device app for remote access
 - Third-party interface options
 - Wired or wireless controllers
- Pocket inside the access panel for kumo cloud® Wireless Interface

Specifications		System	
Unit Type		MLZ-KP18NA2	
Cooling Capacity ^{1,3}		BTU/H	18,000
Heating Capacity ^{2,3}		BTU/H	20,000
Electrical	Voltage, Phase, Frequency		208/230, 1, 60
	Guaranteed Voltage Range	V AC	187- 253V
	Voltage: Indoor - Outdoor, S1-S2	V AC	208/230
	Voltage: Indoor - Outdoor, S2-S3	V DC	24
	Short-circuit Current Rating [SCCR]	kA	5
Indoor Unit	MCA	A	1.0
	Fan Motor Full Load Amperage	A	0.68
	Airflow Rate at Cooling, Dry	CFM	212–311–346–403
	Airflow Rate at Cooling, Wet	CFM	180–249–294–343
	Airflow Rate at Heating, Dry	CFM	212–311–364–417
	Sound Pressure Level [Cooling]	dB[A]	29–36–41–47
	Sound Pressure Level [Heating]	dB[A]	26–37–42–48
	Drain Pipe Size	In. [mm]	1-1/4 [32]
	Condensate Lift Mechanism, Maximum Distance	In. [mm]	19-11/16 [500]
	Coating on Heat Exchanger		—
	External Finish Color		Munsell 4.0GY 9.1/0.2
	Unit Dimensions	W x D x H: In. [mm]	43-3/8 x 14-3/16 x 7-5/16 [1,102 x 360 x 185]
	Package Dimensions	W x D x H: In. [mm]	46-5/16 x 15-3/4 x 11-1/8 [1,177 x 400 x 284]
	Unit Weight	Lbs. [kg]	35 [16]
Package Weight	Lbs. [kg]	42 [19]	
Refrigerant	Type		R410A
Piping	Gas Pipe Size O.D. [Flared]	In.[mm]	1/2 [12.7]
	Liquid Pipe Size O.D. [Flared]	In.[mm]	1/4 [6.35]

NOTES:

Conditions

¹Cooling (Indoor // Outdoor) °F 80 DB, 67 WB // 95 DB, 75 WB
²Heating at 47°F (Indoor // Outdoor) °F 70 DB, 60 WB // 47 DB, 43 WB

³Capacity varies based on the number of indoor units operating and the model of the Multi-zone Outdoor Unit. For reference to connected capacity charts, please refer Multi-zone Outdoor Unit Operational Performance.:

INDOOR UNIT ACCESSORIES: MLZ-KP18NA2

Control Interface	BACnet® and Modbus® Interface	PAC-UKPRC001-CN-1
	CN24 Relay Kit	CN24RELAY-KIT-CM3
	IT Extender	PAC-WHS01IE-E
	kumo station® for kumo cloud®	PAC-WHS01HC-E
	Lockdown bracket for remote controller	RCMKP1CB
	System Control Interface	MAC-334IF-E
	Thermostat Interface	PAC-US444CN-1
	Thermostat Interface	PAC-US445CN-1
	USNAP Adapter	PAC-WHS01UP-E
	Wireless Interface for kumo cloud®	PAC-USWHS002-WF-2
Remote Sensor	Wired Remote Sensor	M21EAA307
	Wireless temperature and humidity sensor for kumo cloud®	PAC-USWHS003-TH-1
Wired Remote Controller	Deluxe Wired MA Remote Controller†	PAR-40MAAU
	Simple MA Remote Controller†	PAC-YT53CRAU-J
	Touch MA Controller†	PAR-CT01MAU-SB
Wireless Remote Controller	kumo touch™ RedLINK™ Wireless Controller	MHK2
Condensate	Blue Diamond (Advanced) Mini Condensate Pump w/ Reservoir & Sensor (208/230V) [recommended]	X87-721
	Blue Diamond (MicroBlue) Mini Condensate Pump (110/208/230V) up to 18,000 BTU/H	X86-003
	Refco Condensate Pump (100-240 VAC) up to 120,000 BTU/H	COMBI
Disconnect Switch	(30A/600V/UL) [fits 2" X 4" utility box] - Black	TAZ-MS303
	(30A/600V/UL) [fits 2" X 4" utility box] - White	TAZ-MS303W
Filter	Anti-allergy Enzyme Filter	MAC-408FT-E
Grille	Grille (required)	MLP-444WU
Lineset	100' x 1/4" x 100' / 1/2" Lineset (Twin-Tube Insulation)	MLS141212T-100
	15' x 1/4" x 15' / 1/2" Lineset (Twin-Tube Insulation)	MLS141212T-15
	30' x 1/4" x 30' / 1/2" Lineset (Twin-Tube Insulation)	MLS141212T-30
	50' x 1/4" x 50' / 1/2" Lineset (Twin-Tube Insulation)	MLS141212T-50
	65' x 1/4" x 65' / 1/2" Lineset (Twin-Tube Insulation)	MLS141212T-65

NOTES:

†Requires MAC-334IF-E

- M-Series EZ FIT® Recessed Ceiling Cassette, Floor-mount and Wall-mount
Allows indoor units to connect to an MA Controller:
 - Deluxe MA Remote Controller
 - Simple MA Controller
 - Touch MA Controller

INDOOR UNIT DIMENSIONS: MLZ-KP18NA2

Unit: inch

INDOOR UNIT OUTLINE DRAWING

(TOP VIEW)

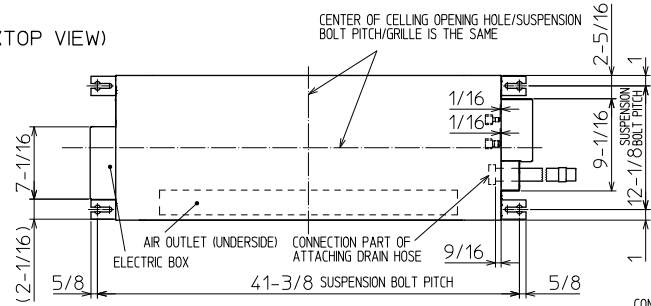

(FRONT VIEW)

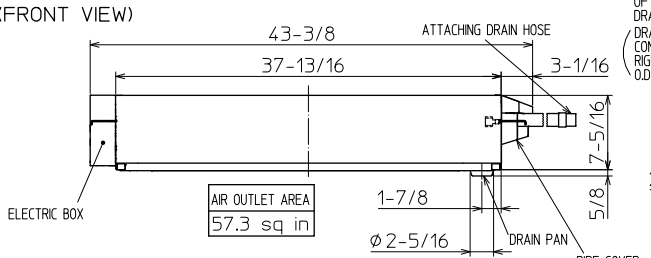

REMOTE CONTROLLER OUTLINE DRAWING

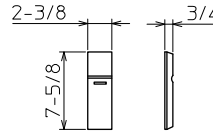

(RIGHT SIDE VIEW)

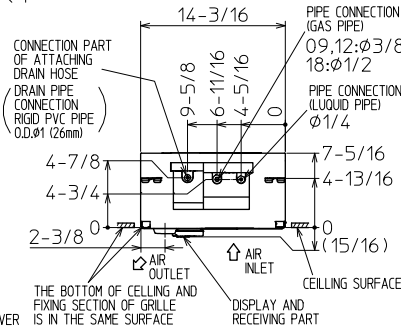

GRILLE OUTLINE DRAWING (MLP-444W)

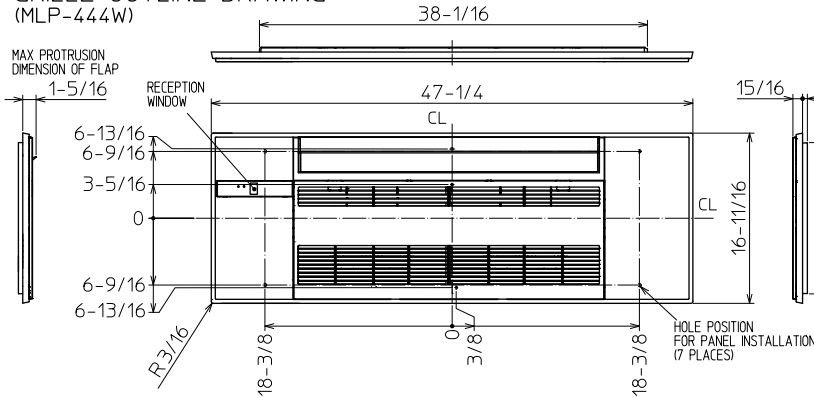

		KP09/12NA	KP18NA
EXTENSION PIPE	LIQUID PIPE O.D.	φ1/4	
	GAS PIPE O.D.	φ3/8	φ1/2
CONNECTION OF PIPE	LIQUID PIPE	FLARED CONNECTION φ1/4	
	GAS PIPE	FLARED CONNECTION φ3/8	FLARED CONNECTION φ1/2
DRAIN HOSE	HEAT INSULATOR O.D.	φ1-1/4	φ1
	CONNECTION I.D.	φ1	φ1
	EFFECTIVE LENGTH	18-7/8	
DRAIN PIPE CONNECTION	RIGID PVC PIPE O.D. φ1 (26mm)		

NOTE1. CUT THE DRAIN HOSE (ACCESSORY) FOR USE, IF NECESSARY.

INDOOR UNIT DETAIL VIEW (TOP VIEW)

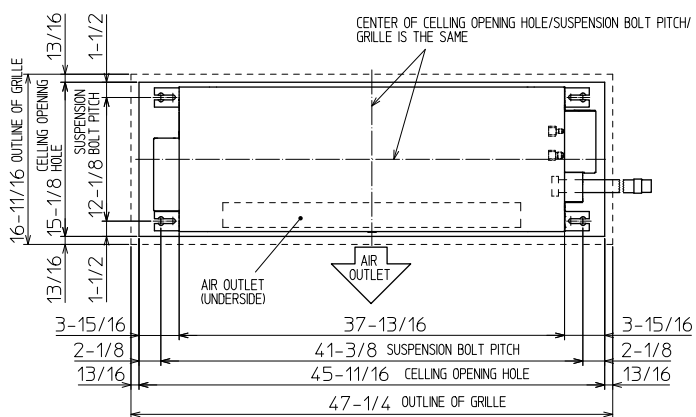

(FRONT VIEW)

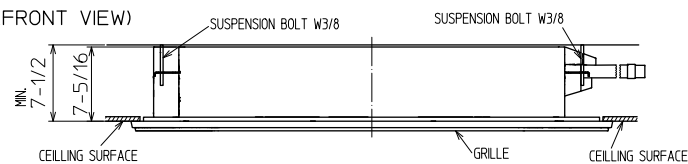

THE METHOD FOR STANDING DRAIN FROM INDOOR UNIT
* CUT THE DRAIN HOSE (ACCESSORY) FOR USE, IF NECESSARY.

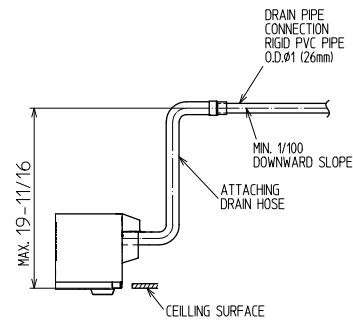

1340 Satellite Boulevard Suwanee, GA 30024
Toll Free: 800-433-4822 www.mehvac.com



MXZ-4C36NA3 3-TON MULTI-ZONE INVERTER HEAT-PUMP SYSTEM



Job Name:

System Reference:

Date:

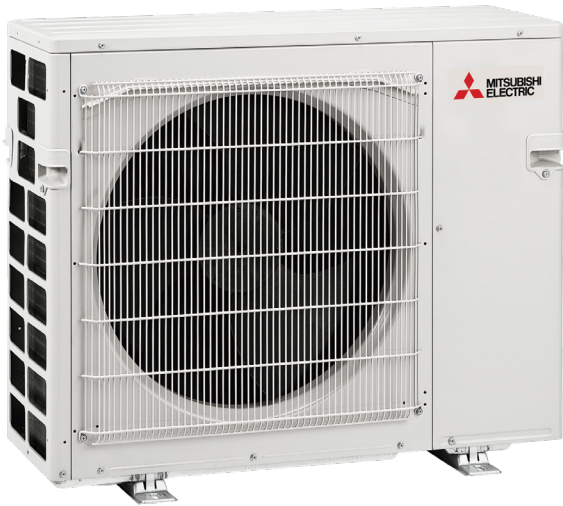

FEATURES

- Variable speed INVERTER-driven compressor
- Optional base pan heater
- Quiet outdoor unit operation as low as 54 dB(A)
- High pressure protection
- Compressor thermal protection
- Compressor overcurrent detection
- Fan motor overheating/voltage protection

SPECIFICATIONS: MXZ-4C36NA3

Indoor unit connection	Maximum Number of Connected IDU		4
	Minimum Number of Connected IDU		2
	Minimum connected capacity	BTU/H	12,000
	Maximum connected capacity	BTU/H	42,000
Piping	Liquid Pipe Size O.D. (Flared)	In.[mm]	A,B,C,D: 1/4 [A,B,C,D: 6.35]
	Gas Pipe Size O.D. (Flared)	In.[mm]	A: 1/2; B,C,D: 3/8 [A: 12.72; B,C,D: 9.52]
	Total Piping Length	Ft. [m]	230 [70]
	Maximum Height Difference, ODU above IDU	Ft. [m]	49 [15]
	Maximum Height Difference, ODU below IDU	Ft. [m]	49 [15]
	Farthest Piping Length from ODU to IDU	Ft. [m]	82 [25]
	Maximum Number of Bends for IDU		70

NOTES:

AHRI Rated Conditions (Rated data is determined at a fixed compressor speed)

¹ Cooling (Indoor // Outdoor)	°F	80 DB, 67 WB // 95 DB, 75 WB
² Heating at 47°F (Indoor // Outdoor)	°F	70 DB, 60 WB // 47 DB, 43 WB
³ Heating at 17°F (Indoor // Outdoor)	°F	70 DB, 60 WB // 17 DB, 15 WB

Conditions ⁴Heating at 5°F (Indoor // Outdoor) °F 70 DB, 60 WB // 5 DB, 4 WB

*Applications should be restricted to comfort cooling only; equipment cooling applications are not recommended for low ambient temperature conditions.

*^ 5°F DB - 115°F DB when optional wind baffles are installed

For actual capacity performance based on indoor unit type and number of indoor units connected, please refer to MXZ Operational Performance. Although the maximum connectable capacity is 130%, the outdoor unit cannot provide more than 100% of the rated capacity. Please utilize this over capacity capability for load shedding or applications where it is known that all connected units will NOT be operating at the same time.

OUTDOOR UNIT ACCESSORIES: MXZ-4C36NA3

Ball Valve	Refrigeration Ball Valve - 1/2"	BV12FFSI2
	Refrigeration Ball Valve - 1/4"	BV14FFSI2
	Refrigeration Ball Valve - 3/8"	BV38FFSI2
	Refrigeration Ball Valve - 5/8"	BV58FFSI2
Control Wire	M-Net Control Wire, 1,000' Roll (16-AWG, Standard, Twisted Pair, Shielded, Jacketed- Plenum rated)	CW162S-1000
	M-Net Control Wire, 250' Roll (16-AWG, Standard, Twisted Pair, Shielded, Jacketed- Plenum rated)	CW162S-250
Drain Socket	Drain Socket	PAC-SG60DS-E
Hail Guards	Hail Guard	HG-A9
M-NET Converter	M-NET Converter	PAC-IF01MNT-E
Mini-Split Wire	14 Gauge, 4 wire MiniSplit Cable—250 ft. roll	S144-250
	14 Gauge, 4 wire MiniSplit Cable—250 ft. roll	SW144-250
	14 Gauge, 4 wire MiniSplit Cable—50 ft. roll	S144-50
	14 Gauge, 4 wire MiniSplit Cable—50 ft. roll	SW144-50
	16 Gauge, 4 wire MiniSplit Cable—250 ft. roll	S164-250
	16 Gauge, 4 wire MiniSplit Cable—250 ft. roll	SW164-250
	16 Gauge, 4 wire MiniSplit Cable—50 ft. roll	S164-50
	16 Gauge, 4 wire MiniSplit Cable—50 ft. roll	SW164-50
Mounting Pad	Condensing Unit Mounting Pad: 16" x 36" x 3"	ULTRILITE1
	Outdoor Unit 3-1/4 inch Mounting Base (Pair) - Plastic	DSD-400P
Optional Defrost Heater	Optional Defrost Heater	PAC-645BH-E
Port Adapter	Adaptor: 1/2" x 3/8"	MAC-A455JP-E
	Adaptor: 1/2" x 5/8"	MAC-A456JP-E
	Adaptor: 3/8" x 1/2"	MAC-A454JP-E
	Adaptor: 3/8" x 5/8"	PAC-SG76RJ-E
Stand	18" Single Fan Stand	QSMS1801M
	24" Single Fan Stand	QSMS2401M
	Condenser Wall Bracket	QSWB2000M-1
	Condenser Wall Bracket - Stainless Steel Finish	QSWBSS
	Outdoor Unit Stand — 12" High	QSMS1201M

MLZ-KY06NA 6,000 BTU/H EZ FIT CEILING CASSETTE



Job Name:

System Reference:

Date:



GENERAL FEATURES

- Designed to fit between I-joist spacing
- Stylish, square design panel
- Built-in condensate lift mechanism (19.6")
- Serviceable from the bottom (electrical and flare connections)
- Adjustable fan speeds and vane directions
- Washable antibacterial and deodorizing filter
- Multiple control options available:
 - Hand-held Remote Controller (provided with unit)
 - kumo cloud® smart device app for remote access
 - Third-party interface options
 - Wired or wireless controllers
- Pocket inside the access panel for kumo cloud® Wireless Interface
- UL 60335-2-40 Compliant

Specifications		System		
Unit Type		MLZ-KY06NA		
Cooling Capacity ^{1,3}	BTU/H	6,000		
Heating Capacity ^{2,3}	BTU/H	7,200		
Electrical	Voltage, Phase, Frequency		208/230, 1, 60	
	Guaranteed Voltage Range		187- 253V	
	Voltage: Indoor - Outdoor, S1-S2		V AC 208/230	
	Voltage: Indoor - Outdoor, S2-S3		V DC 24	
	Short-circuit Current Rating [SCCR]		kA 5	
Indoor Unit	MCA		A 1.0	
	Fan Motor Full Load Amperage		A 0.68	
	Airflow Rate at Cooling, Dry		CFM 152-173-184-198	
	Airflow Rate at Cooling, Wet		CFM 129-141-156-168	
	Airflow Rate at Heating, Dry		CFM 152-173-194-212	
	Drain Pipe Size		In. [mm] 1-1/16 [26]	
	Condensate Lift Mechanism, Maximum Distance		In. [mm] 19-11/16 [500]	
	Coating on Heat Exchanger		—	
	External Finish Color		Munsell 4.0GY 9.1/0.2	
	Unit Dimensions		W x D x H: In. [mm]	33-3/16 x 11-7/8 x 7-11/16 [842 x 301 x 194]
	Package Dimensions		W x D x H: In. [mm]	35-3/4 x 14-1/8 x 12-1/8 [910 x 360 x 310]
	Unit Weight		Lbs. [kg]	24.3 [11.0]
	Package Weight		Lbs. [kg]	28.7 [13.0]
Refrigerant	Type		R410A	
Piping	Gas Pipe Size O.D. [Flared]		In.[mm] 3/8 [9.52]	
	Liquid Pipe Size O.D. [Flared]		In.[mm] 1/4 [6.35]	

NOTES:

Conditions

¹Cooling (Indoor // Outdoor)

°F 80 DB, 67 WB // 95 DB, 75 WB

²Heating at 47°F (Indoor // Outdoor)

°F 70 DB, 60 WB // 47 DB, 43 WB

³Capacity varies based on the number of indoor units operating and the model of the Multi-zone Outdoor Unit. For reference to connected capacity charts, please refer Multi-zone Outdoor Unit Operational Performance.:

INDOOR UNIT ACCESSORIES: MLZ-KY06NA

Control Interface	BACnet® and Modbus® Interface	PAC-UKPRC001-CN-1
	CN24 Relay Kit	CN24RELAY-KIT-CM3
	IT Extender	PAC-WHS01IE-E
	kumo station® for kumo cloud®	PAC-WHS01HC-E
	Lockdown bracket for remote controller	RCMKP1CB
	System Control Interface	MAC-334IF-E
	Thermostat Interface	PAC-US444CN-1
	Thermostat Interface	PAC-US445CN-1
	USNAP Adapter	PAC-WHS01UP-E
	Wireless Interface for kumo cloud®	PAC-USWHS002-WF-2
Remote Sensor	Wired Remote Sensor	M21EAA307
	Wireless temperature and humidity sensor for kumo cloud®	PAC-USWHS003-TH-1
Wired Remote Controller	Deluxe Wired MA Remote Controller†	PAR-40MAAU
	Simple MA Remote Controller†	PAC-YT53CRAU-J
	Touch MA Controller†	PAR-CT01MAU-SB
Wireless Remote Controller	kumo touch™ RedLINK™ Wireless Controller	MHK2
Condensate	Blue Diamond (Advanced) Mini Condensate Pump w/ Reservoir & Sensor (208/230V) [recommended]	X87-721
	Blue Diamond (MicroBlue) Mini Condensate Pump (110/208/230V) up to 18,000 BTU/H	X86-003
	Refco Condensate Pump (100-240 VAC) up to 120,000 BTU/H	COMBI
Disconnect Switch	(30A/600V/UL) [fits 2" X 4" utility box] - Black	TAZ-MS303
	(30A/600V/UL) [fits 2" X 4" utility box] - White	TAZ-MS303W
Filter	Anti-allergy Enzyme Filter	MAC-408FT-E
Grille	Grille (required)	MLP-448WU
Lineset	15' x 1/4" x 15' / 3/8" Lineset (Twin-Tube Insulation)	MLS143812T-15
	30' x 1/4" x 30' / 3/8" Lineset (Twin-Tube Insulation)	MLS143812T-30
	50' x 1/4" x 50' / 3/8" Lineset (Twin-Tube Insulation)	MLS143812T-50
	65' x 1/4" x 65' / 3/8" Lineset (Twin-Tube Insulation)	MLS143812T-65

NOTES:

†Requires MAC-334IF-E

- M-Series EZ FIT® Recessed Ceiling Cassette, Floor-mount and Wall-mount
Allows indoor units to connect to an MA Controller:
 - Deluxe MA Remote Controller
 - Simple MA Controller
 - Touch MA Controller

INDOOR UNIT DIMENSIONS: MLZ-KY06NA

Unit: inch

INDOOR UNIT OUTLINE DRAWING

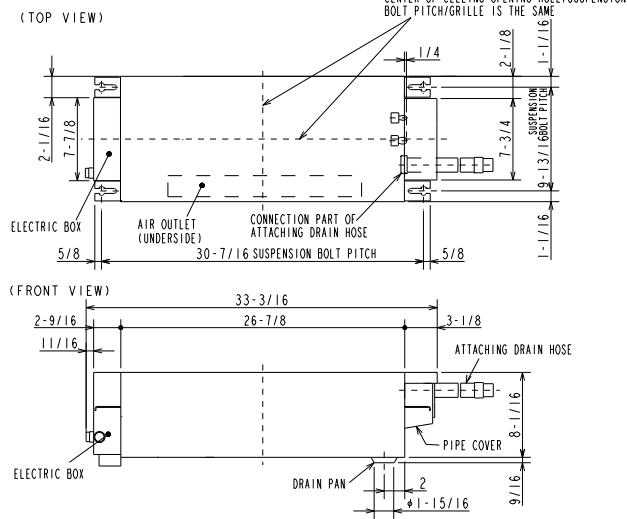

REMOTE CONTROLLER OUTLINE DRAWING

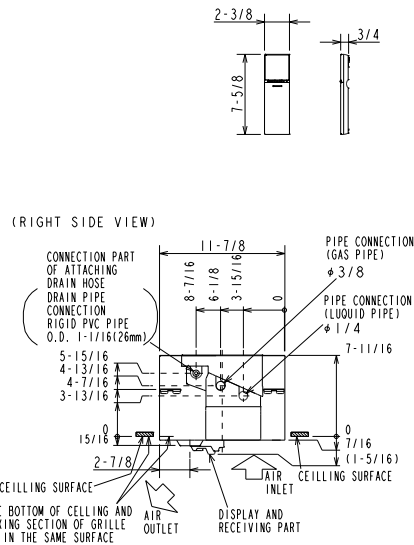

GRILLE OUTLINE DRAWING (MLP-448WU)

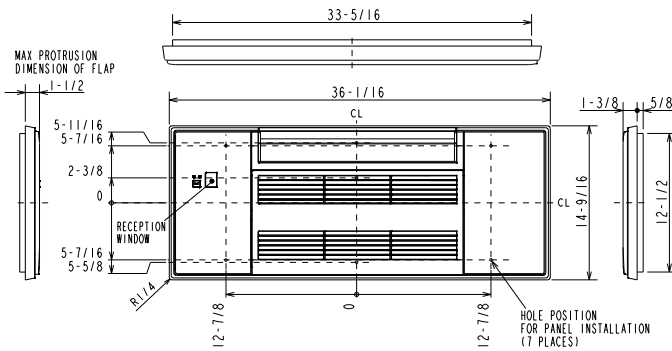

EXTENSION PIPE	LIQUID PIPE O.D.	$\phi 1/4$	
	GAS PIPE O.D.	$\phi 3/8$	
CONNECTION OF PIPE	LIQUID PIPE	FLARED CONNECTION $\phi 1/4$	
	GAS PIPE	FLARED CONNECTION $\phi 3/8$	
DRAIN HOSE	HEAT INSULATOR O.D.	CONNECTION I.D.	EFFECTIVE LENGTH
	$\phi 1-5/16$	$\phi 1$	18-15/16
	DRAIN PIPE CONNECTION RIGID PVC PIPE O.D. $\phi 1-1/16$ (26mm)		

NOTE1. CUT THE DRAIN HOSE (ACCESSORY) FOR USE, IF NECESSARY.

INDOOR UNIT DETAIL VIEW

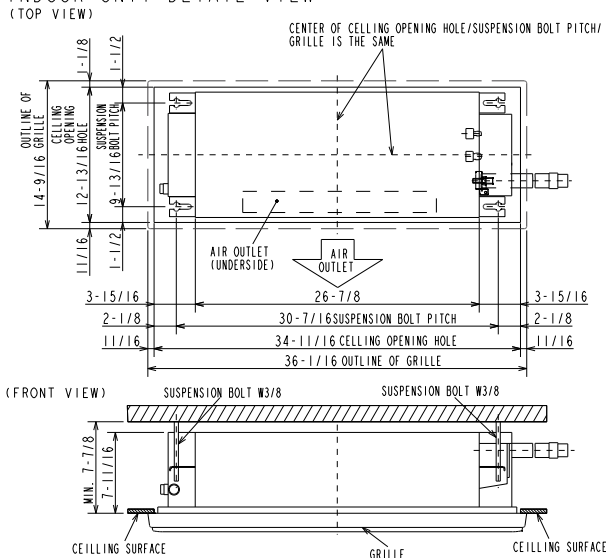

THE METHOD FOR STANDING DRAIN FROM INDOOR UNIT
* CUT THE DRAIN HOSE (ACCESSORY) FOR USE, IF NECESSARY.

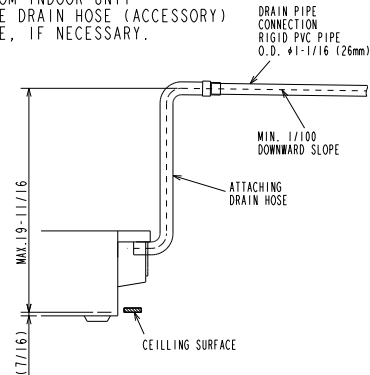

1340 Satellite Boulevard Suwanee, GA 30024
Toll Free: 800-433-4822 www.mehvac.com

FORM# MLZ-KY06NA-U1 - 202209

