

**MSZ-FS15NA & MUZ-FS15NA
15,000 BTU/H DELUXE WALL MOUNT
15,000 BTU/H HYPER-HEATING OUTDOOR UNIT**



Job Name:

System Reference:

Date:



Indoor Unit.....MSZ-FS15NA

Outdoor Unit.....MUZ-FS15NA



INDOOR UNIT FEATURES

- Slim wall-mounted indoor units provide zone comfort control
- Dual Barrier Coating applied to the heat exchanger, vanes and fan to prevent hydrophilic and hydrophobic dirt build-up
- Multiple fan speed options: Quiet, Low, Medium, High, Super-high, Auto
- 3D i-see Sensor® enables advance features:
 - Indirect or Direct Airflow for personalized comfort
 - Absence Detection for energy-saving mode
 - Double Vane features:
 - Separates airflow to deliver air across a large area
 - Simultaneously deliver to air separate sections of a room
 - Generates more comfortable natural airflow pattern
- Multiple control options available:
 - Back-lit screen handheld remote controller (provided with unit)
 - kumo cloud® smart device app for remote access
 - Third-party interface options
 - Wired or wireless controllers
- Triple-action Filtration: Nano Platinum Filter, Deodorizing Filter, & Electrostatic Anti-Allergy Enzyme Filter
- Hot-Start Technology: no cold air rush at equipment startup or when restarting after Defrost Cycle
- Quiet operation

OUTDOOR UNIT FEATURES

- INVERTER-driven compressor and LEV provide high efficiency and comfort while using only the energy needed to maintain maximum performance
- H2i plus™ performance offers 100% heating capacity at -5° and 70% to 81% heating capacity at -13° F
- Blue Fin anti-corrosion treatment applied to the outdoor unit heat exchanger for increased coil protection and longer life

SPECIFICATIONS: MSZ-FS15NA & MUZ-FS15NA

Cooling at 95°F ¹	Maximum Capacity	BTU/H	19,000
	Rated Capacity	BTU/H	14,000
	Minimum Capacity	BTU/H	6,450
	Maximum Power Input	W	2,010
	Rated Power Input	W	1,000
	Moisture Removal	Pints/h	4.0
	Sensible Heat Factor		0.7
Heating at 47°F ²	Power Factor	%	96.0/96.0
	Maximum Capacity	BTU/H	24,000
	Rated Capacity	BTU/H	16,000
	Minimum Capacity	BTU/H	5,150
	Maximum Power Input	W	3,360
	Rated Power Input	W	1,155
Heating at 17°F ³	Power Factor	%	98.0/98.0
	Maximum Capacity	BTU/H	22,730
	Rated Capacity	BTU/H	10,000
	Maximum Power Input	W	3,090
Heating at 5°F ⁴	Rated Power Input	W	830
	Maximum Capacity	BTU/H	19,360
Heating at -5°F ⁶	Maximum Power Input	W	2,610
Heating at -13°F ⁷	Maximum Capacity	BTU/H	16,000
	Maximum Capacity	BTU/H	14,400
Efficiency	SEER		22.2
	EER ¹		14.0
	HSPF [IV]		12.5
	COP at 47°F ²		4.06
	COP at 17°F at Maximum Capacity ³		2.16
	COP at 5°F at Maximum Capacity ⁴		2.01
	COP at -5°F at Maximum Capacity ⁶		2.01
	COP at -13°F at Maximum Capacity ⁷		2.01
Electrical	ENERGY STAR® Certified		Yes
	Voltage, Phase, Frequency		208/230, 1, 60
	Guaranteed Voltage Range	V AC	187 - 253
	Voltage: Indoor - Outdoor, S1-S2	V AC	208/230
	Voltage: Indoor - Outdoor, S2-S3	V DC	24
	Short-circuit Current Rating [SCCR]	kA	5
	Recommended Fuse/Breaker Size (Outdoor)	A	20
Indoor Unit	Recommended Wire Size [Indoor - Outdoor]	AWG	14
	MCA	A	1.0
	Fan Motor Full Load Amperage	A	0.65
	Fan Motor Output	W	40
	Airflow Rate at Cooling, Dry	CFM	225-262-304-355-437
	Airflow Rate at Cooling, Wet	CFM	194-225-261-305-376
	Airflow Rate at Heating, Dry	CFM	201-272-350-410-514
	Sound Pressure Level [Cooling]	dB[A]	27-31-35-39-44
	Sound Pressure Level [Heating]	dB[A]	25-31-37-40-46
	Drain Pipe Size	In. [mm]	5/8 [15.88]
	Coating on Heat Exchanger		Dual Barrier Coating
	External Finish Color		Munsell 1.0Y 9.2/0.2
	Unit Dimensions	W x D x H: In. [mm]	36-7/16 x 9-3/16 x 12 (+11/16) [925 x 234 x 305 (+17)]
	Package Dimensions	W x D x H: In. [mm]	39 x 12-1/4 x 15-1/2 [990 x 310 x 400]
Unit Weight	Lbs. [kg]	29 [13.5]	
Package Weight	Lbs. [kg]	34 [15.4]	
Indoor Unit Operating Temperature Range	Cooling Intake Air Temp [Maximum / Minimum]*	°F	90 DB, 73 WB / 67 DB, 57 WB
	Heating Intake Air Temp [Maximum / Minimum]	°F	80 DB / 70 DB

NOTES:

AHRI Rated Conditions (Rated data is determined at a fixed compressor speed)

¹ Cooling (Indoor // Outdoor)	°F	80 DB, 67 WB // 95 DB, 75 WB
² Heating at 47°F (Indoor // Outdoor)	°F	70 DB, 60 WB // 47 DB, 43 WB
³ Heating at 17°F (Indoor // Outdoor)	°F	70 DB, 60 WB // 17 DB, 15 WB

Conditions	⁴ Heating at 5°F (Indoor // Outdoor)	°F	70 DB, 60 WB // 5 DB, 4 WB
	⁵ Heating at -4°F (Indoor // Outdoor)	°F	70 DB, 60 WB // -4 DB, -5 WB
	⁶ Heating at -5°F (Indoor // Outdoor)	°F	70 DB, 60 WB // -5 DB, -6 WB
	⁷ Heating at -13°F (Indoor // Outdoor)	°F	70 DB, 60 WB // -13 DB, -14 WB

*Outdoor Unit Operating Temperature Range (Cooling Air Temp (Maximum / Minimum)):

- Applications should be restricted to comfort cooling only; equipment cooling applications are not recommended for low ambient temperature conditions.
- For P-Series only:
 - » Wind baffles required to operate below 23°F DB in cooling mode.
 - » Cooling-only system with wind baffle: -40°F - 115°F.
 - » Heat pump system with wind baffle: 0°F - 115°F.
 - » Refer to wind baffle documentation for further information.

**Outdoor Unit Operating Temperature Range (Cooling Thermal Lock-out / Re-start Temperatures; Heating Thermal Lock-out / Re-start Temperatures):

- System cuts out in heating mode to avoid thermistor error and automatically restarts at these temperatures.
- SEACOAST PROTECTION (ONLY APPLIES TO P-SERIES -BS MODELS)
 - External Outer Panel: Phosphate coating + Acrylic-Enamel coating
 - Fan Motor Support: Epoxy resin coating (at edge face)
 - Separator Assembly Valve Bed: Epoxy resin coating (at edge face)
 - Blue Fin treatment is an anti-corrosion treatment that is applied to the condenser coil to protect it against airborne contaminants.

SPECIFICATIONS: MSZ-FS15NA & MUZ-FS15NA

Outdoor Unit	MCA	A	18.0
	MOCP	A	20
	Fan Motor Full Load Amperage	A	0.93
	Fan Motor Output	W	50
	Airflow Rate	CFM	1801/1949
	Refrigerant Control		LEV
	Defrost Method		Reverse Cycle
	Coating on Heat Exchanger		Blue Fin Coating
	Sound Pressure Level, Cooling ¹	dB(A)	51
	Sound Pressure Level, Heating ²	dB(A)	55
	Compressor Type		Twin Rotary
	Compressor Model		SNB172FQKMT
	Compressor Rated Load Amps	A	17.0
	Compressor Locked Rotor Amps	A	13.6
	Compressor Oil Type // Charge	oz.	FV50S // 0.40
	External Finish Color		Munsell 3Y 7.8/1.1
	Base Pan Heater		Optional
	Unit Dimensions	W x D x H: In. [mm]	33-1/16 x 13 x 34-5/8 [840 x 330 x 880]
	Package Dimensions	W x D x H: In. [mm]	38-3/4 x 16-3/4 x 39 [980 x 420 x 990]
	Unit Weight	Lbs. [kg]	117 [53]
Package Weight	Lbs. [kg]	134 [60.5]	
Outdoor Unit Operating Temperature Range	Cooling Air Temp [Maximum / Minimum]*	°F	115 DB / 14 DB
	Cooling Thermal Lock-out / Re-start Temperatures**	°F	-4 / 0
	Heating Air Temp [Maximum / Minimum]	°F	75 DB, 65 WB / -13 DB, -14 WB
	Heating Thermal Lock-out / Re-start Temperatures**	°F	-18 / -14
Refrigerant	Type		R410A
	Charge	Lbs, oz	3, 7
	Chargeless Piping Length	Ft. [m]	25 [7.5]
	Additional Refrigerant Charge Per Additional Piping Length	oz./Ft. [g/m]	0.216 [20]
Piping	Gas Pipe Size O.D. [Flared]	In.[mm]	1/2 [12.7]
	Liquid Pipe Size O.D. [Flared]	In.[mm]	1/4 [6.35]
	Maximum Piping Length	Ft. [m]	100 [30]
	Maximum Height Difference	Ft. [m]	50 [15]
	Maximum Number of Bends		10

NOTES:

AHRI Rated Conditions

(Rated data is determined at a fixed compressor speed)

¹ Cooling (Indoor // Outdoor)	°F	80 DB, 67 WB // 95 DB, 75 WB
² Heating at 47°F (Indoor // Outdoor)	°F	70 DB, 60 WB // 47 DB, 43 WB
³ Heating at 17°F (Indoor // Outdoor)	°F	70 DB, 60 WB // 17 DB, 15 WB

Conditions

⁴ Heating at 5°F (Indoor // Outdoor)	°F	70 DB, 60 WB // 5 DB, 4 WB
⁵ Heating at -4°F (Indoor // Outdoor)	°F	70 DB, 60 WB // -4 DB, -5 WB
⁶ Heating at -5°F (Indoor // Outdoor)	°F	70 DB, 60 WB // -5 DB, -6 WB
⁷ Heating at -13°F (Indoor // Outdoor)	°F	70 DB, 60 WB // -13 DB, -14 WB

*Outdoor Unit Operating Temperature Range (Cooling Air Temp (Maximum / Minimum)):

- Applications should be restricted to comfort cooling only; equipment cooling applications are not recommended for low ambient temperature conditions.

• For P-Series only:

- » Wind baffles required to operate below 23°F DB in cooling mode.
- » Cooling-only system with wind baffle: -40°F - 115°F.
- » Heat pump system with wind baffle: 0°F - 115°F.
- » Refer to wind baffle documentation for further information.

**Outdoor Unit Operating Temperature Range (Cooling Thermal Lock-out / Re-start Temperatures; Heating Thermal Lock-out / Re-start Temperatures):

- System cuts out in heating mode to avoid thermistor error and automatically restarts at these temperatures.

SEACOAST PROTECTION (ONLY APPLIES TO P-SERIES -BS MODELS)

- External Outer Panel: Phosphate coating + Acrylic-Enamel coating
- Fan Motor Support: Epoxy resin coating (at edge face)
- Separator Assembly Valve Bed: Epoxy resin coating (at edge face)
- Blue Fin treatment is an anti-corrosion treatment that is applied to the condenser coil to protect it against airborne contaminants.

INDOOR UNIT ACCESSORIES: MSZ-FS15NA

Control Interface	BACnet® and Modbus Interface	PAC-UKPRC001-CN-1
	CN24 Relay Kit	CN24RELAY-KIT-CM3
	IT Extender	PAC-WHS01IE-E
	kumo station® for kumo cloud®	PAC-WHS01HC-E
	Lockdown bracket for remote controller	RCMKP1CB
	System Control Interface	MAC-334IF-E
	Thermostat Interface	PAC-US444CN-1
	USNAP Adapter	PAC-WHS01UP-E
Remote Sensor	Wireless Interface for kumo cloud®	PAC-USWHS002-WF-2
	Wired Remote Sensor	M21EAA307
Wired Remote Controller	Wireless temperature and humidity sensor for kumo cloud®	PAC-USWHS003-TH-1
	Deluxe Wired MA Remote Controller†	PAR-40MAAU
	Simple MA Remote Controller†	PAC-YT53CRAU-J
Wireless Remote Controller	Touch MA Controller†	PAR-CT01MAU-SB
	kumo touch™ RedLINK™ Wireless Controller	MHK2
Condensate	Blue Diamond (MicroBlue) Mini Condensate Pump (110/208/230V) up to 18,000 BTU/H	X85-003
	Blue Diamond Alarm Extension Cable — 6.5 Ft.	C13-192
	Blue Diamond MultiTank — collection tank for use with multiple pumps	C21-014
	Blue Diamond Sensor Extension Cable — 15 Ft.	C13-103
	Drain Pan Level Sensor/Control	SS610E
	Fascia Kit for MicroBlue Pump, mounts the MicroBlue and sensor directly beneath indoor unit	T18-016
	Sauermann Condensate Pump	SI30-230
Disconnect Switch	(30A/600V/UL) [fits 2" X 4" utility box] - Black	TAZ-MS303
	(30A/600V/UL) [fits 2" X 4" utility box] - White	TAZ-MS303W
Filter	Electro Static Anti-allergy Enzyme Filter	MAC-2330FT-E
	Platinum Deodorizing Filter	MAC-3000FT-E
Lineset	15' x 1/4" x 15' / 1/2" Lineset (Twin-Tube Insulation)	MLS141212T-15
	30' x 1/4" x 30' / 1/2" Lineset (Twin-Tube Insulation)	MLS141212T-30
	50' x 1/4" x 50' / 1/2" Lineset (Twin-Tube Insulation)	MLS141212T-50
	65' x 1/4" x 65' / 1/2" Lineset (Twin-Tube Insulation)	MLS141212T-65

NOTES:

†Requires MAC-334IF-E

- M-Series EZ FIT® Recessed Ceiling Cassette, Floor-mount and Wall-mount
Allows indoor units to connect to an MA Controller:
 - Deluxe MA Remote Controller
 - Simple MA Controller
 - Touch MA Controller

‡PAC-SF40RM-E (Unable to use with wireless remote controller)

- M-Series Ceiling Cassette, Ceiling Suspended, Horizontal-ducted and Multi-position Air Handler
- P-Series Ceiling Cassette, Ceiling Suspended, Horizontal-ducted and Multi-position Air Handler

OUTDOOR UNIT ACCESSORIES: MUZ-FS15NA

Condensate	Drain Socket	MAC-871DS
Control/Service Tool	M- & P-Series Maintenance Tool Cable Set	M21EC0397
	USB/UART Conversion Cable (Required for all laptop connection)	M21EC1397
Hail Guards	Hail Guard	HG-A7
Mini-Split Wire	14 Gauge, 4 wire MiniSplit Cable—250 ft. roll	S144-250
	14 Gauge, 4 wire MiniSplit Cable—50 ft. roll	S144-50
	16 Gauge, 4 wire MiniSplit Cable—250 ft. roll	S164-250
	16 Gauge, 4 wire MiniSplit Cable—50 ft. roll	S164-50
Mounting Pad	Condensing Unit Mounting Pad: 16" x 36" x 3"	ULTRILITE1
	Outdoor Unit 3-1/4 inch Mounting Base (Pair) - Plastic	DSD-400P
Optional Defrost Heater	Base Heater	MAC-642BH-U1
Stand	18" Single Fan Stand	QSMS1801M
	24" Single Fan Stand	QSMS2401M
	Condenser Wall Bracket	QSWB2000M-1
	Condenser Wall Bracket -Stainless Steel Finish	QSWBSS
	Outdoor Unit Stand — 12" High	QSMS1201M

INDOOR UNIT DIMENSIONS: MSZ-FS15NA

Unit: inch

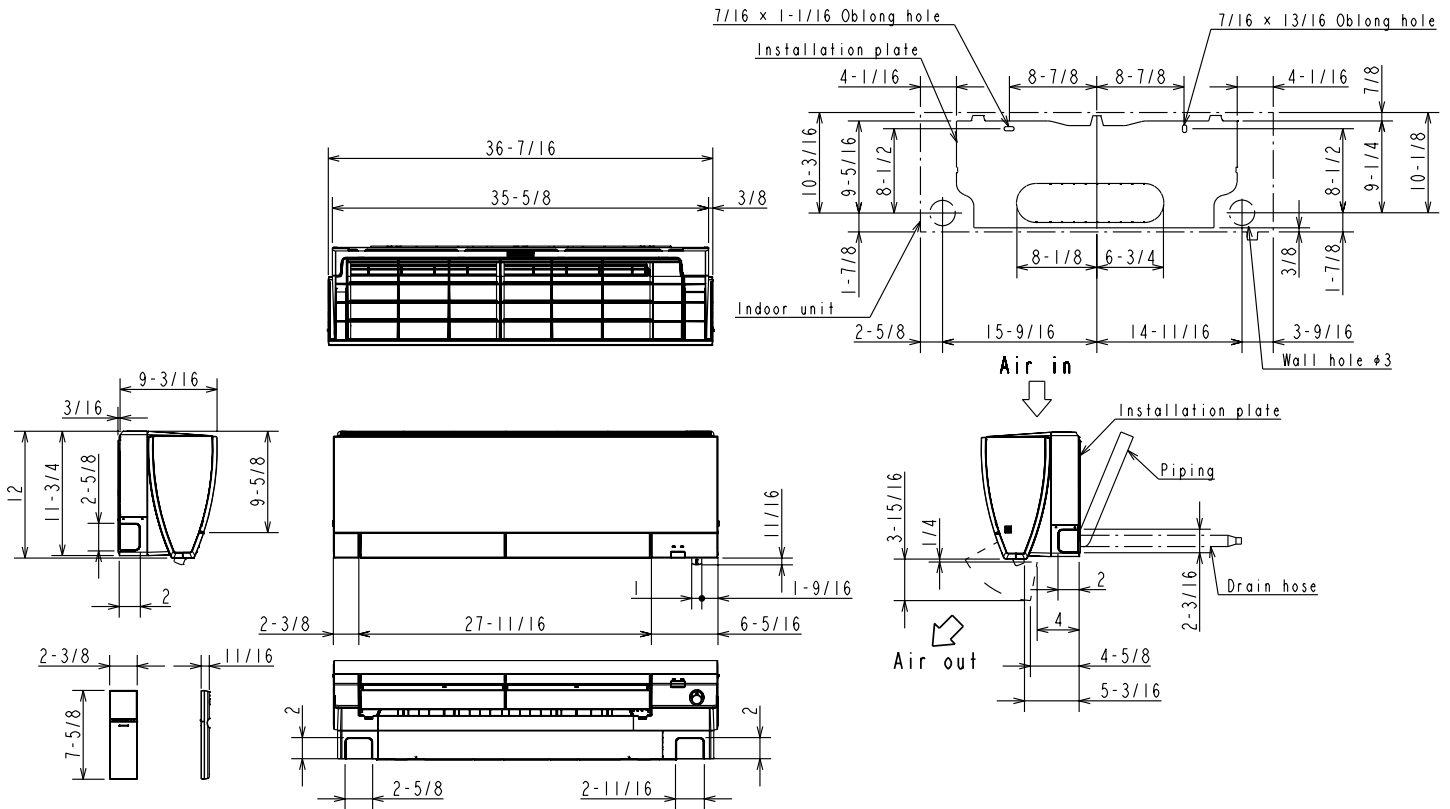

(06/09/12 KBTU/H)

Piping	Insulation	φ1-7/16 O.D
	Liquid line	φ1/4 19-11/16 (Flared connection φ1/4)
	Gas line	φ3/8 16-15/16 (Flared connection φ3/8)
	Drain hose	Insulation φ1-1/8 Connected part φ5/8 O.D

(15/18 KBTU/H)

Piping	Insulation	φ1-7/16 O.D
	Liquid line	φ1/4 19-11/16 (Flared connection φ1/4)
	Gas line	φ3/8 16-15/16 (Flared connection φ1/2)
	Drain hose	Insulation φ1-1/8 Connected part φ5/8 O.D

OUTDOOR UNIT DIMENSIONS: MUZ-FS15NA

Unit: inch

REQUIRED SPACE

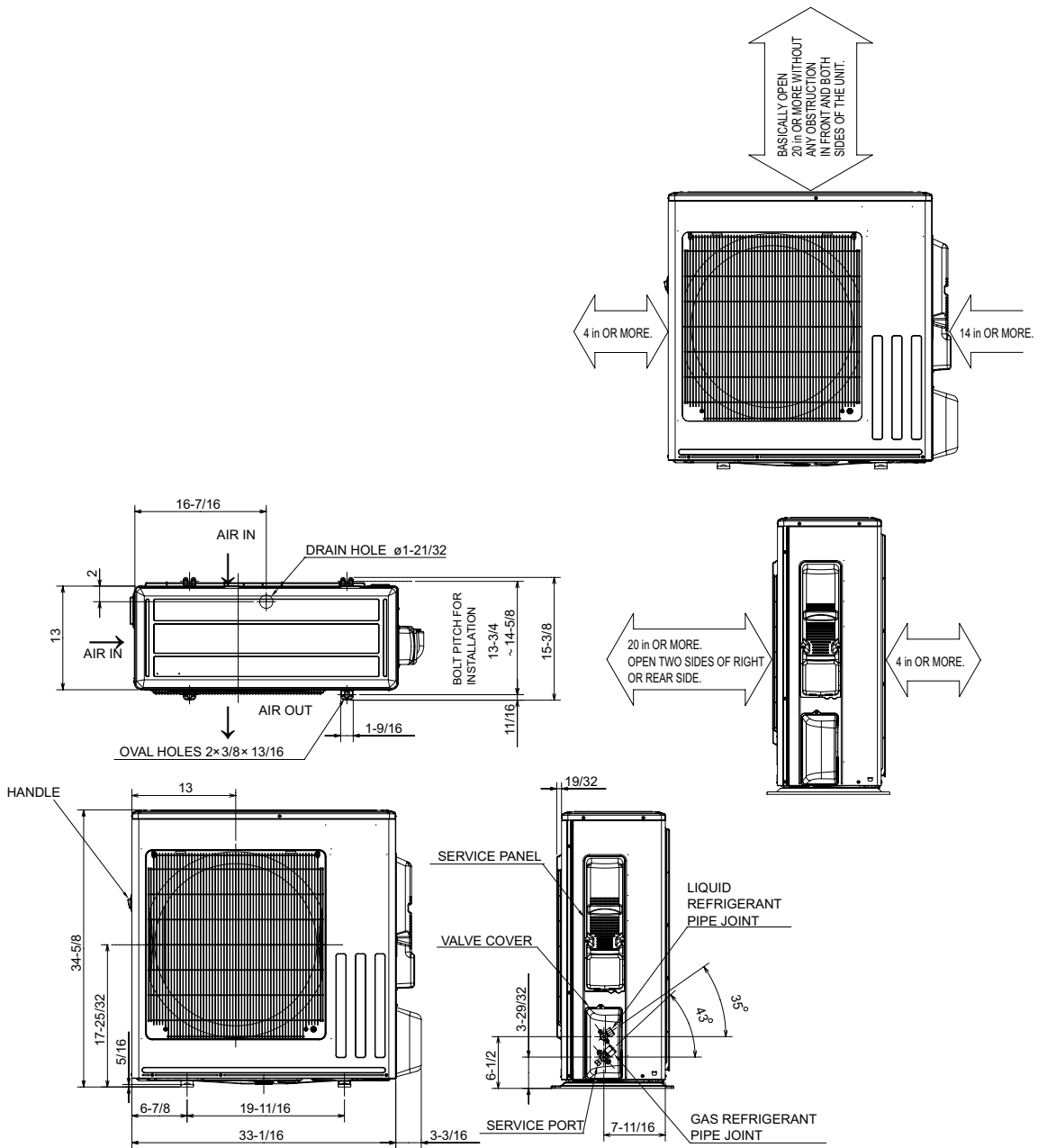

REFRIGERANT PIPE JOINT	LIQUID REFRIGERANT PIPE	FLARED $\phi 6.35 (1/4")$
	GAS REFRIGERANT PIPE	FLARED $\phi 12.7 (1/2")$

1340 Satellite Boulevard Suwanee, GA 30024
Toll Free: 800-433-4822 www.mehvac.com

FORM# MSZ-FS15NA-U1 & MUZ-FS15NA-U1 - 202101

