

SPLIT-TYPE AIR CONDITIONERS

Revision A:

- A warning when opening or closing the valve has been added.

OBH875 is void.

OUTDOOR UNIT

SERVICE MANUAL



No. OBH875
REVISED EDITION-A

Models

MUZ-GS30NA - U1

MUZ-GS36NA - U1

MUY-GS30NA - U1

MUY-GS36NA - U1

MUZ-GS30NAH - U1

MUZ-GS36NAH - U1

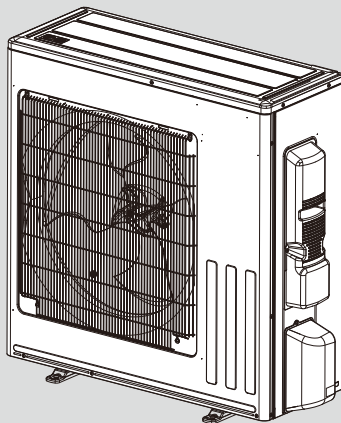

Indoor unit service manual
MSZ-GS•NA, MSY-GS•NA Series (OBH874)

CONTENTS

1. TECHNICAL CHANGES	2
2. PART NAMES AND FUNCTIONS	3
3. SPECIFICATION	4
4. OUTLINES AND DIMENSIONS	6
5. WIRING DIAGRAM	7
6. REFRIGERANT SYSTEM DIAGRAM	9
7. DATA	11
8. ACTUATOR CONTROL	18
9. SERVICE FUNCTIONS	19
10. TROUBLESHOOTING	20
11. DISASSEMBLY INSTRUCTIONS	40

PARTS CATALOG (OBB875)

Use the specified refrigerant only

Never use any refrigerant other than that specified.

Doing so may cause a burst, an explosion, or fire when the unit is being used, serviced, or disposed of.

Correct refrigerant is specified in the manuals and on the spec labels provided with our products.

We will not be held responsible for mechanical failure, system malfunction, unit breakdown or accidents caused by failure to follow the instructions.

<Preparation before the repair service>

- Prepare the proper tools.
- Prepare the proper protectors.
- Provide adequate ventilation.
- After stopping the operation of the air conditioner, turn off the power-supply breaker and pull the power plug.
- Discharge the capacitor before the work involving the electric parts.

<Precautions during the repair service>

- Do not perform the work involving the electric parts with wet hands.
- Do not pour water into the electric parts.
- Do not touch the refrigerant.
- Do not touch the hot or cold areas in the refrigeration cycle.
- When the repair or the inspection of the circuit needs to be done without turning off the power, exercise great caution not to touch the live parts.

WARNING

- When the refrigeration circuit has a leak, do not execute pump down with the compressor.
- When pumping down the refrigerant, stop the compressor before disconnecting the refrigerant pipes. The compressor may burst if air etc. get into it.
- When opening or closing the valve below freezing temperatures, refrigerant may spurt out from the gap between the valve stem and the valve body, resulting in injuries.

Revision A:

- A warning when opening or closing the valve has been added.

1

TECHNICAL CHANGES

MUZ-GS30NA MUZ-GS30NAH

MUZ-GS36NA MUZ-GS36NAH

MUY-GS30NA

MUY-GS36NA

1. New model

2

PART NAMES AND FUNCTIONS

MUZ-GS30NA MUZ-GS30NAH MUZ-GS36NA MUZ-GS36NAH MUY-GS30NA MUY-GS36NA

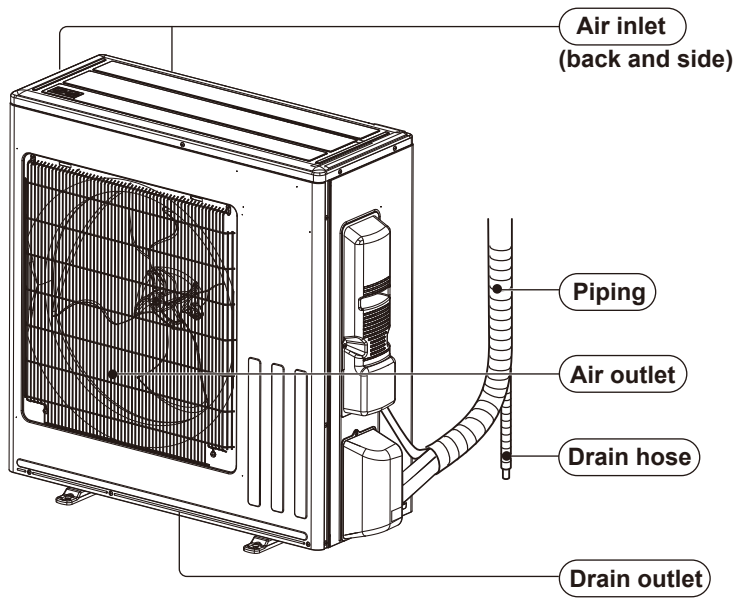

3

SPECIFICATION

Outdoor unit model			MUZ-GS30NA MUZ-GS30NAH MUY-GS30NA	MUZ-GS36NA MUZ-GS36NAH MUY-GS36NA
Capacity Rated (Minimum~Maximum)	Cooling *1	Btu/h	30,700 (10,300 ~ 30,700)	32,000/33,200 (10,300 ~ 32,000)/(10,300 ~ 33,200)
	Heating 47 *1,3	Btu/h	32,600 (9,800 ~ 34,000)	35,200 (9,800 ~ 36,000)
Capacity Rated (Maximum)	Heating 17 *2,3	Btu/h	20,000 (20,800)	21,600 (22,800)
Power consumption Rated (Minimum~Maximum)	Cooling *1	W	3,320 (650 ~ 3,320)	3,630/3,770 (650 ~ 3,630)/(650 ~ 3,770)
	Heating 47 *1,3	W	3,340 (590 ~ 3,580)	3,740 (590 ~ 4,000)
Power consumption Rated (Maximum)	Heating 17 *2,3	W	2,500 (2,600)	2,770 (2,920)
EER *1 [SEER] *4	Cooling		9.2 [18.1]	8.8 [16.2]
HSPF IV *5	Heating *3		NA: 9.6	NA: 10
			NAH: 9.4	NAH: 9.8
COP	Heating *1,3		2.86	2.76
Power supply	V , phase , Hz		208/230, 1 , 60	
Max. fuse size (time delay)	A		20	
Min. circuit ampacity	A		19	
Fan motor	F.L.A	A	0.93	
Compressor	Model		SNB220FQAM1T	
	R.L.A	A	13.8	
	L.R.A	A	17.3	
	Refrigeration oil	fl oz. (L)/(Model)	15.6 (0.46)/(FV50S)	
Refrigerant control			Linear expansion valve	
Sound level *1	Cooling	dB(A)	55	56
	Heating *3	dB(A)	57	
Defrost method			Reverse cycle	
Dimensions	W	in.	33-1/16	
	D	in.	13	
	H	in.	34-5/8	
Weight			NA: 121	
			NAH: 122	
External finish			Munsell 3Y 7.8/1.1	
Remote controller			Wireless type	
Control voltage (by built-in transformer)		V DC	12 - 24	
Refrigerant piping			Not supplied	
Refrigerant pipe size (Min. wall thickness)	Liquid	in.	1/4 (0.0315)	
	Gas	in.	5/8 (0.0394)	
Connection method	Indoor		Flared	
	Outdoor		Flared	
Between the indoor & outdoor units	Height difference	ft.	50	
	Piping length	ft.	100	
Refrigerant charge (R410A)			4 lb.	

NOTE: Test conditions are based on AHRI 210/240.

*1: Rating conditions (Cooling) — Indoor: 80°FDB, 67°FWB, Outdoor: 95°FDB, (75°FWB)
(Heating) — Indoor: 70°FDB, 60°FWB, Outdoor: 47°FDB, 43°FWB

*2: Rating conditions (Heating) — Indoor: 70°FDB, 60°FWB, Outdoor: 17°FDB, 15°FWB

*3: Only MUZ

Test condition

*4, *5

AHRI 210/240	Mode	Test	Indoor air condition (°F)		Outdoor air condition (°F)	
			Dry bulb	Wet bulb	Dry bulb	Wet bulb
	SEER (Cooling)	"A-Full" Cooling Steady State at rated compressor speed	80	67	95	(75)
		"B-Full" Cooling Steady State at rated compressor speed	80	67	82	(65)
		"B-Low" Cooling Steady State at minimum compressor speed	80	67	82	(65)
		"F-Low" Cooling Steady State at minimum compressor speed	80	67	67	(53.5)
		"E-Int" Cooling Steady State at intermediate compressor speed *6	80	67	87	(69)
	HSPF (Heating)	"H1-Nom" Heating Steady State at rated compressor speed	70	60	47	43
		"H3-Full" Heating at rated compressor speed	70	60	17	15
		"H0-Low" Heating Steady State at minimum compressor speed	70	60	62	56.5
		"H1-Low" Heating Steady State at minimum compressor speed	70	60	47	43
		"H2-Int" Heating at intermediate compressor speed *6	70	60	35	33

*6: At intermediate compressor speed
= ("Rated compressor speed" - "minimum compressor speed") / 3 + "minimum compressor speed".

OPERATING RANGE

(1) POWER SUPPLY

	Rated voltage	Guaranteed voltage (V)
Outdoor unit	208/230 V 1 phase 60 Hz	<p>Min. 187 208 230 Max. 253</p>

(2) OPERATION

Mode	Condition	Intake air temperature (°F)			
		Indoor		Outdoor	
		DB	WB	DB	WB
Cooling	Standard temperature	80	67	95	—
	Maximum temperature	90	73	115	—
	Minimum temperature	67	57	14	—
	Maximum humidity	78 %		—	
Heating	Standard temperature	70	60	47	43
	Maximum temperature	80	67	75	65
	Minimum temperature	70	60	-4	-5

4

OUTLINES AND DIMENSIONS

MUZ-GS30NA MUZ-GS30NAH MUZ-GS36NA MUZ-GS36NAH MUY-GS30NA MUY-GS36NA

Unit: inch

REQUIRED SPACE

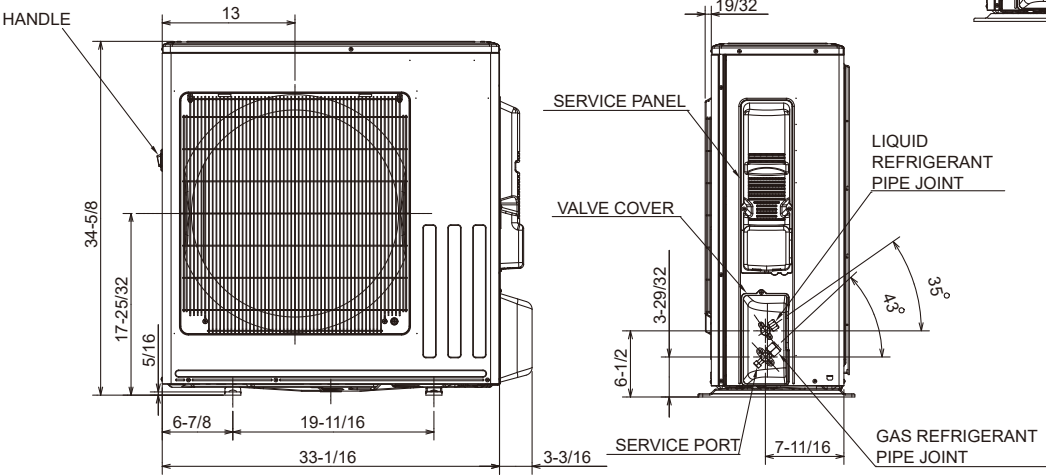
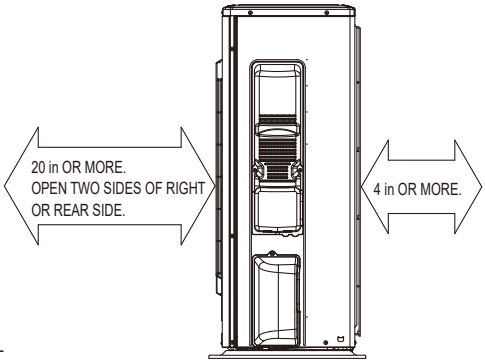
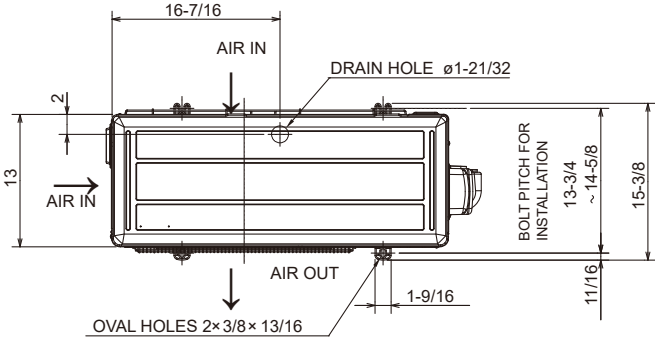
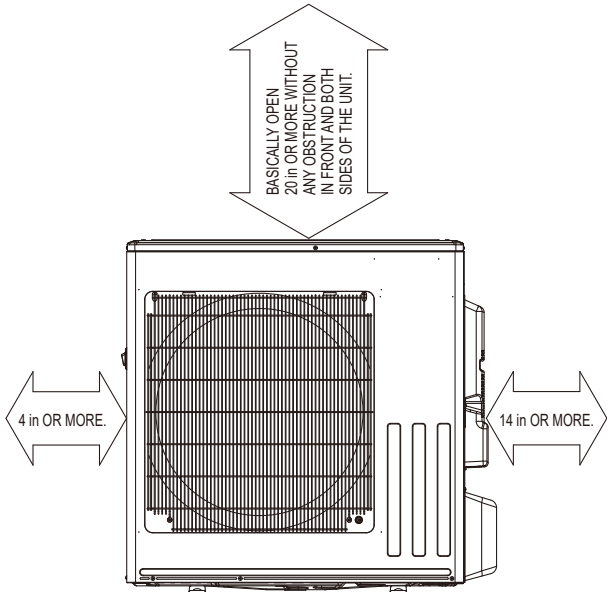

REFRIGERANT PIPE JOINT	LIQUID REFRIGERANT PIPE	FLARED ø6.35 (1/4")
	GAS REFRIGERANT PIPE	FLARED ø15.88 (5/8")

5

WIRING DIAGRAM

MUZ-GS30NA MUZ-GS36NA

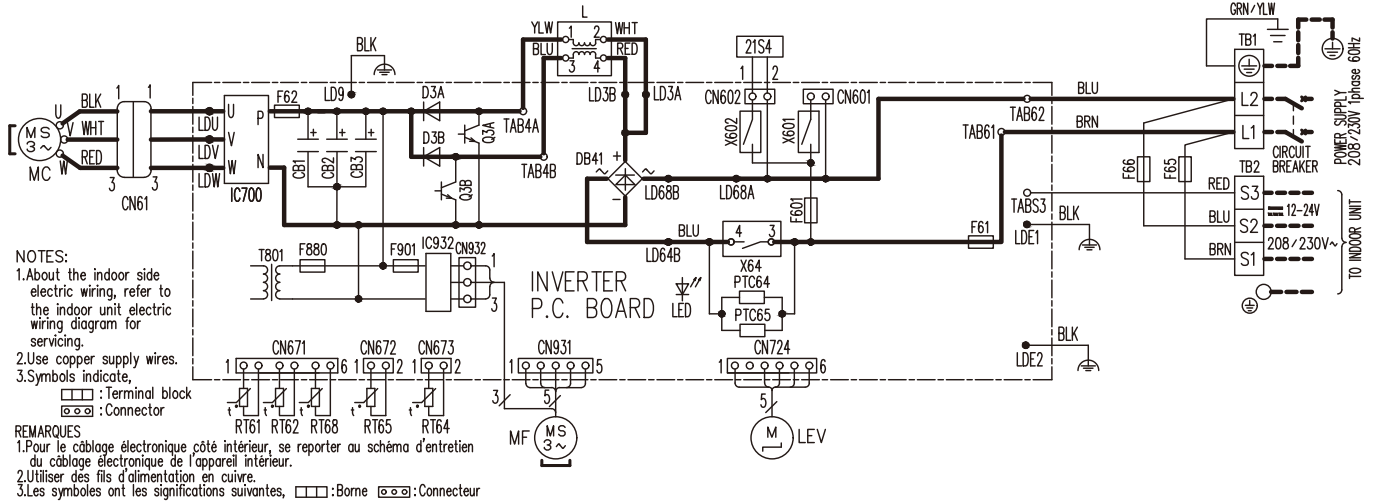

SYMBOL	NAME	SYMBOL	NAME	SYMBOL	NAME
CB1, CB2, CB3	SMOOTHING CAPACITOR	LED	LED	RT68	OUTDOOR HEAT EXCHANGER TEMP. THERMISTOR
CN61	CONNECTOR	LEV	EXPANSION VALVE COIL	TB1, TB2	TERMINAL BLOCK
DB41	DIODE MODULE	MC	COMPRESSOR	T801	TRANSFORMER
D3A, D3B	DIODE	MF	FAN MOTOR	X64, X601, X602	RELAY
F61	FUSE (25A 250V)	PTC64, PTC65	CIRCUIT PROTECTION	21S4	REVERSING VALVE COIL
F62	FUSE (15A 250V)	Q3A, Q3B	SWITCHING POWER TRANSISTOR		
F65, F66	FUSE (T6.3AL250V)	RT61	DEFROST TEMP. THERMISTOR		
F601, F880, F901	FUSE (T3.15AL250V)	RT62	DISCHARGE TEMP. THERMISTOR		
IC700, IC932	POWER MODULE	RT64	FIN TEMP. THERMISTOR		
L	REACTOR	RT65	AMBIENT TEMP. THERMISTOR		

MUZ-GS30NAH MUZ-GS36NAH

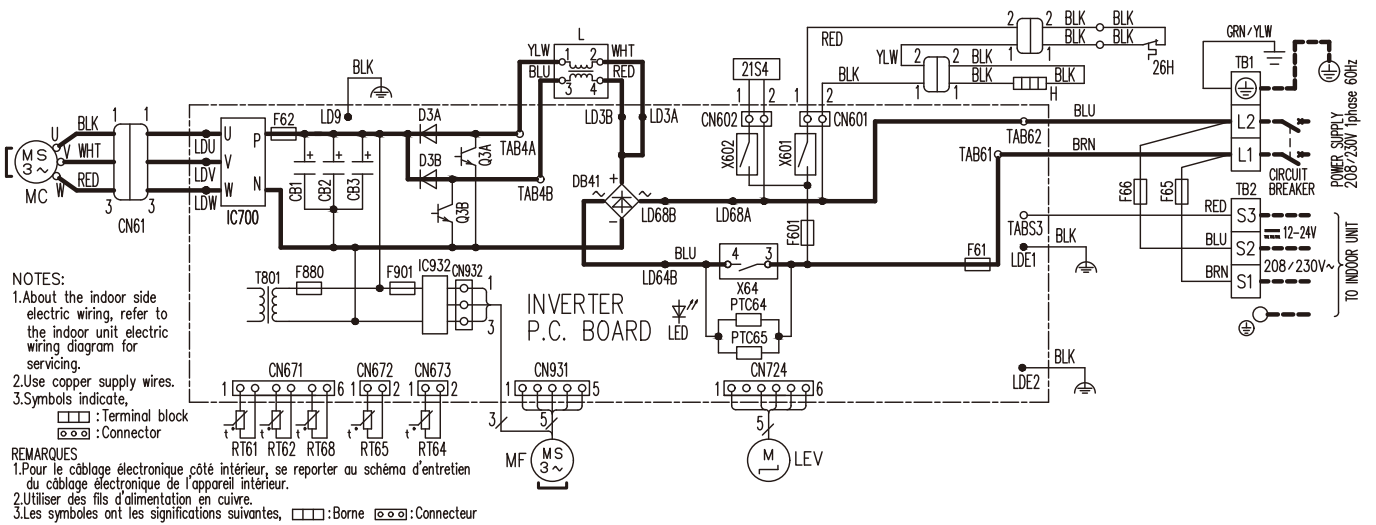

SYMBOL	NAME	SYMBOL	NAME	SYMBOL	NAME
CB1, CB2, CB3	SMOOTHING CAPACITOR	L	REACTOR	RT65	AMBIENT TEMP. THERMISTOR
CN61	CONNECTOR	LED	LED	RT68	OUTDOOR HEAT EXCHANGER TEMP. THERMISTOR
DB41	DIODE MODULE	LEV	EXPANSION VALVE COIL	TB1, TB2	TERMINAL BLOCK
D3A, D3B	DIODE	MC	COMPRESSOR	T801	TRANSFORMER
F61	FUSE (25A 250V)	MF	FAN MOTOR	X64, X601, X602	RELAY
F62	FUSE (15A 250V)	PTC64, PTC65	CIRCUIT PROTECTION	21S4	REVERSING VALVE COIL
F65, F66	FUSE (T6.3AL250V)	Q3A, Q3B	SWITCHING POWER TRANSISTOR	26H	HEATER PROTECTOR
F601, F880, F901	FUSE (T3.15AL250V)	RT61	DEFROST TEMP. THERMISTOR		
H	DEFROST HEATER	RT62	DISCHARGE TEMP. THERMISTOR		
IC700, IC932	POWER MODULE	RT64	FIN TEMP. THERMISTOR		

MUY-GS30NA MUY-GS36NA

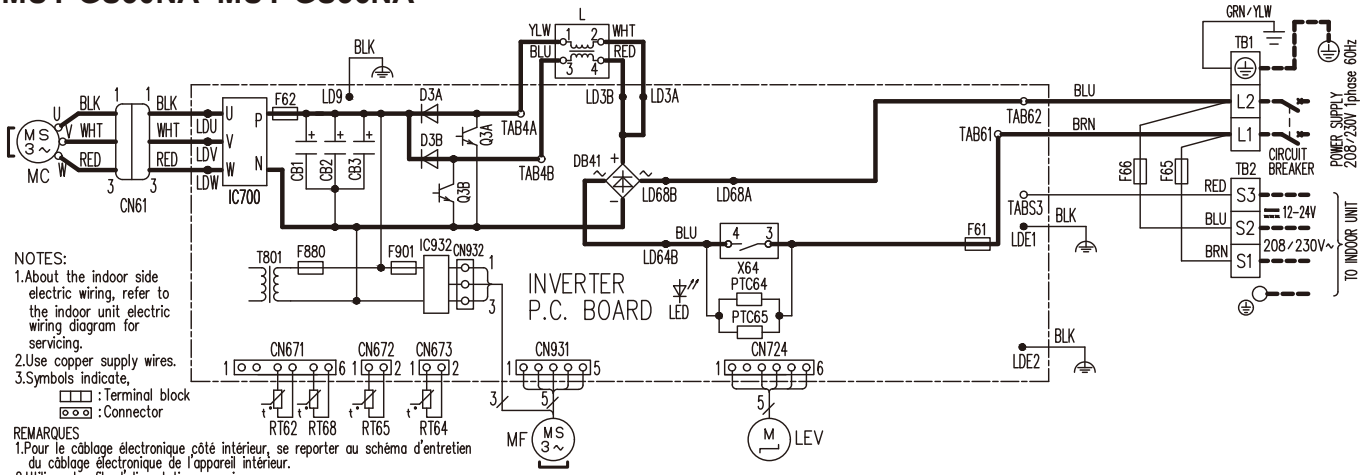

SYMBOL	NAME	SYMBOL	NAME	SYMBOL	NAME
CB1, CB2, CB3	SMOOTHING CAPACITOR	L	REACTOR	RT65	AMBIENT TEMP. THERMISTOR
CN61	CONNECTOR	LED	LED	RT68	OUTDOOR HEAT EXCHANGER TEMP. THERMISTOR
DB41	DIODE MODULE	LEV	EXPANSION VALVE COIL	TB1, TB2	TERMINAL BLOCK
D3A, D3B	DIODE	MC	COMPRESSOR	T801	TRANSFORMER
F61	FUSE (25A 250V)	MF	FAN MOTOR	X64	RELAY
F62	FUSE (15A 250V)	PTC64, PTC65	CIRCUIT PROTECTION		
F65, F66	FUSE (T6.3AL250V)	Q3A, Q3B	SWITCHING POWER TRANSISTOR		
F880, F901	FUSE (T3.15AL250V)	RT62	DISCHARGE TEMP. THERMISTOR		
IC700, IC932	POWER MODULE	RT64	FIN TEMP. THERMISTOR		

6

REFRIGERANT SYSTEM DIAGRAM

MUZ-GS30NA MUZ-GS30NAH MUZ-GS36NA MUZ-GS36NAH MUY-GS30NA MUY-GS36NA

Unit: inch (mm)

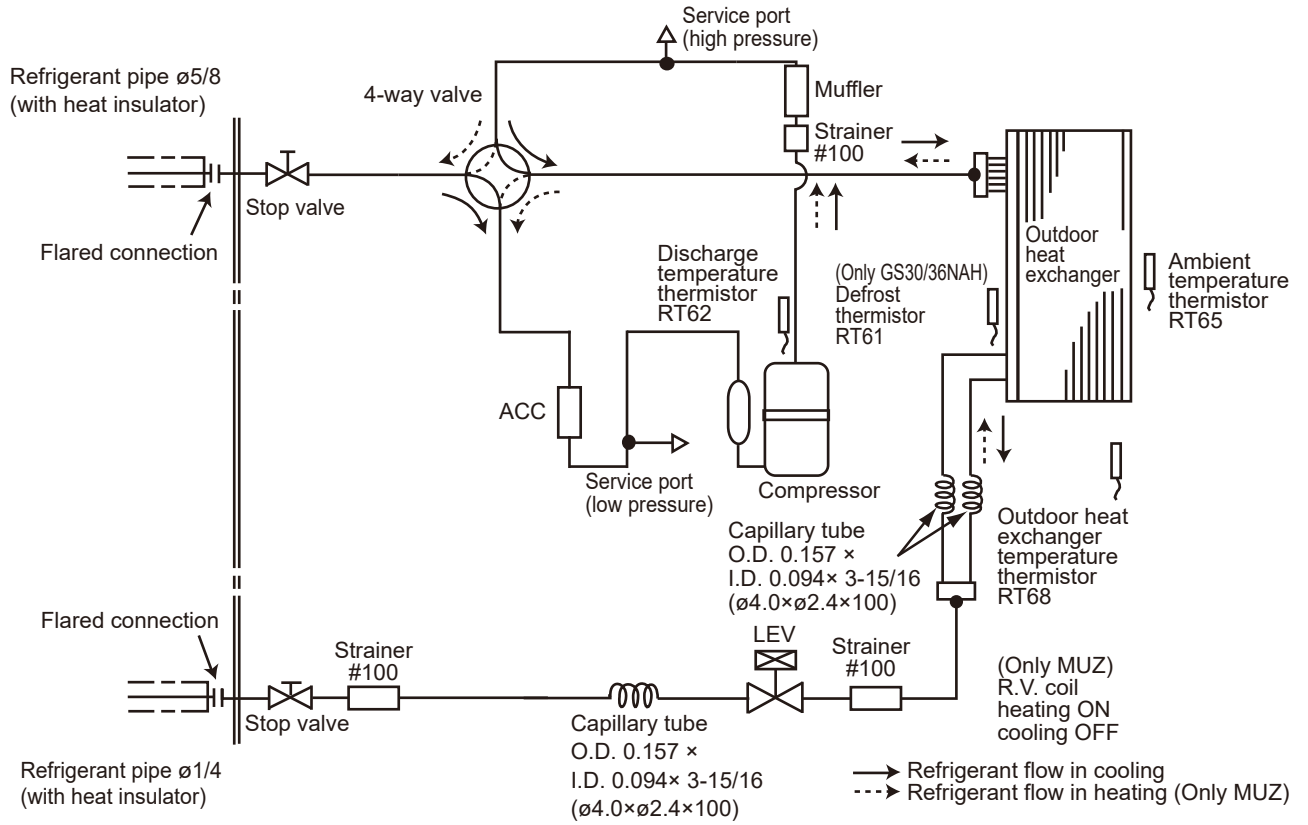

MAX. REFRIGERANT PIPING LENGTH and MAX. HEIGHT DIFFERENCE

Model	Refrigerant piping: ft.		Piping size O.D: in.	
	Max. Length A	Max. Height difference B	Gas	Liquid
MUZ-GS30NA MUZ-GS30NAH MUZ-GS36NA MUZ-GS36NAH MUY-GS30NA MUY-GS36NA	100	50	5/8	1/4

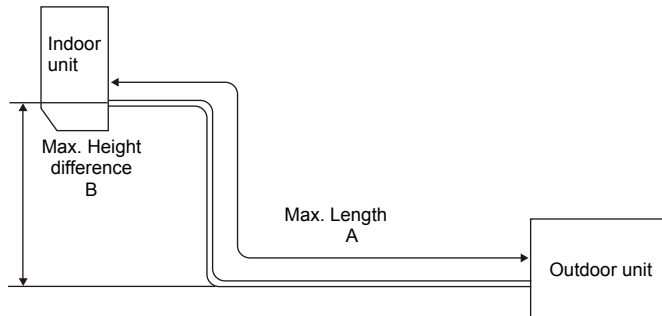

ADDITIONAL REFRIGERANT CHARGE (R410A: oz.)

NOTE: Refrigerant piping exceeding 25 ft. requires additional refrigerant charge according to the calculation.

Model	Outdoor unit precharged	Refrigerant piping length (one way): ft.								
		25	30	40	50	60	70	80	90	100
MUZ-GS30NA MUZ-GS30NAH MUZ-GS36NA MUZ-GS36NAH MUY-GS30NA MUY-GS36NA	4 lb. 0 oz.	0	1.08	3.24	5.40	7.56	9.72	11.88	14.04	16.20

Calculation: X oz. = 1.08/5 oz./ft. × (Refrigerant piping length (ft.) - 25)

MUZ-GS30NA MUZ-GS30NAH MUZ-GS36NA MUZ-GS36NAH MUY-GS30NA MUY-GS36NA
7-1. PERFORMANCE DATA
1) COOLING CAPACITY

Model	Indoor air	Outdoor intake air DB temperature (°F)											
	IWB (°F)	75				85				95			
		TC	SHC	SHF	TPC	TC	SHC	SHF	TPC	TC	SHC	SHF	TPC
MUZ-GS30NA MUZ-GS30NAH MUY-GS30NA	71	37.6	22.1	0.59	2.95	35.2	20.6	0.59	3.24	33.0	19.4	0.59	3.49
	67	35.6	25.6	0.72	2.79	33.2	23.9	0.72	3.07	30.7	22.1	0.72	3.32
	63	33.5	28.6	0.85	2.66	31.0	26.5	0.85	2.94	28.9	24.6	0.85	3.17
MUZ-GS36NA MUZ-GS36NAH MUY-GS36NA (208V)	71	39.2	21.8	0.56	3.23	36.6	20.4	0.56	3.54	34.4	19.1	0.56	3.81
	67	37.1	25.6	0.69	3.05	34.6	23.8	0.69	3.36	32.0	22.1	0.69	3.63
	63	34.9	28.7	0.82	2.90	32.3	26.6	0.82	3.21	30.1	24.8	0.82	3.47
MUZ-GS36NA MUZ-GS36NAH MUY-GS36NA (230V)	71	40.7	22.6	0.56	3.36	38.0	21.2	0.56	3.68	35.7	19.9	0.56	3.96
	67	38.5	26.6	0.69	3.17	35.9	24.7	0.69	3.49	33.2	22.9	0.69	3.77
	63	36.2	29.8	0.82	3.02	33.5	27.6	0.82	3.34	31.2	25.7	0.82	3.60

Model	Indoor air	Outdoor intake air DB temperature (°F)							
	IWB (°F)	105				115			
		TC	SHC	SHF	TPC	TC	SHC	SHF	TPC
MUZ-GS30NA MUZ-GS30NAH MUY-GS30NA	71	30.7	18.0	0.59	3.67	28.2	16.6	0.59	3.82
	67	28.6	20.6	0.72	3.52	26.2	18.9	0.72	3.69
	63	26.2	22.4	0.85	3.39	23.9	20.4	0.85	3.52
MUZ-GS36NA MUZ-GS36NAH MUY-GS36NA (208V)	71	32.0	17.8	0.56	4.01	29.4	16.4	0.56	4.17
	67	29.8	20.5	0.69	3.85	27.4	18.9	0.69	4.03
	63	27.4	22.5	0.82	3.70	25.0	20.6	0.82	3.85
MUZ-GS36NA MUZ-GS36NAH MUY-GS36NA (230V)	71	33.2	18.5	0.56	4.17	30.5	17.0	0.56	4.34
	67	30.9	21.3	0.69	4.00	28.4	19.6	0.69	4.18
	63	28.4	23.4	0.82	3.85	25.9	21.3	0.82	4.00

NOTE: 1. IWB : Intake air wet-bulb temperature TC : Total Capacity (x10³Btu/h)
 SHC : Sensible Heat Capacity (x10³Btu/h) SHF : Sensible Heat Factor
 TPC : Total Power Consumption (kW)
 2. SHC is based on 80°F of indoor Intake air DB temperature.

2) COOLING CAPACITY CORRECTIONS

	Refrigerant piping length (one way: ft.)			
	25 (std.)	40	65	100
MUZ-GS30NA MUZ-GS30NAH MUY-GS30NA	1.0	0.976	0.937	0.887
MUZ-GS36NA MUZ-GS36NAH MUY-GS36NA	1.0	0.974	0.932	0.878

3) HEATING CAPACITY CORRECTIONS

	Refrigerant piping length (one way: ft.)			
	25 (std.)	40	65	100
MUZ-GS30NA MUZ-GS30NAH MUZ-GS36NA MUZ-GS36NAH	1.0	0.997	0.993	0.987

4) HEATING CAPACITY

Model	Indoor air IDB (°F)	Outdoor intake air WB temperature (°F)													
		5		15		25		35		43		45		55	
		TC	TPC	TC	TPC	TC	TPC	TC	TPC	TC	TPC	TC	TPC	TC	TPC
MUZ-GS30NA	75	14.3	1.97	18.9	2.49	23.6	2.92	28.2	3.26	31.8	3.42	32.8	3.47	37.2	3.61
	70	15.5	1.89	20.0	2.40	24.5	2.86	28.9	3.17	32.6	3.34	33.6	3.41	38.0	3.54
	65	16.3	1.80	20.5	2.30	25.6	2.76	29.8	3.09	33.6	3.26	34.6	3.31	38.8	3.47
MUZ-GS30NAH	75	14.3	2.09	18.9	2.61	23.6	3.04	28.2	3.26	31.8	3.42	32.8	3.47	37.2	3.61
	70	15.5	2.01	20.0	2.52	24.5	2.98	28.9	3.17	32.6	3.34	33.6	3.41	38.0	3.54
	65	16.3	1.92	20.5	2.42	25.6	2.88	29.8	3.09	33.6	3.26	34.6	3.31	38.8	3.47
MUZ-GS36NA	75	15.5	2.21	20.4	2.79	25.5	3.27	30.4	3.65	34.3	3.83	35.4	3.89	40.1	4.04
	70	16.7	2.11	21.6	2.69	26.4	3.20	31.2	3.55	35.2	3.74	36.3	3.81	41.0	3.96
	65	17.6	2.02	22.2	2.58	27.6	3.09	32.2	3.46	36.3	3.65	37.3	3.70	41.9	3.89
MUZ-GS36NAH	75	15.5	2.33	20.4	2.91	25.5	3.39	30.4	3.65	34.3	3.83	35.4	3.89	40.1	4.04
	70	16.7	2.23	21.6	2.81	26.4	3.32	31.2	3.55	35.2	3.74	36.3	3.81	41.0	3.96
	65	17.6	2.14	22.2	2.70	27.6	3.21	32.2	3.46	36.3	3.65	37.3	3.70	41.9	3.89

NOTE: 1. IDB : Intake air dry-bulb temperature

TC : Total Capacity (x10³ Btu/h)

TPC : Total Power Consumption (kW)

2. Above data is for heating operation without any frost.

7-2. PERFORMANCE CURVE

Cooling

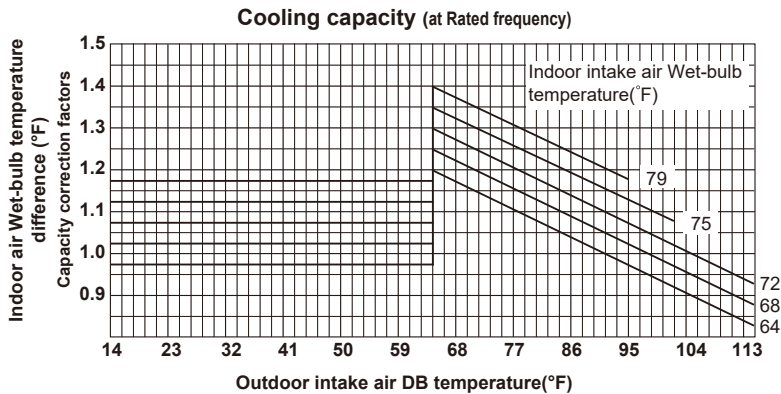

MUZ-GS30NA MUZ-GS30NAH MUY-GS30NA

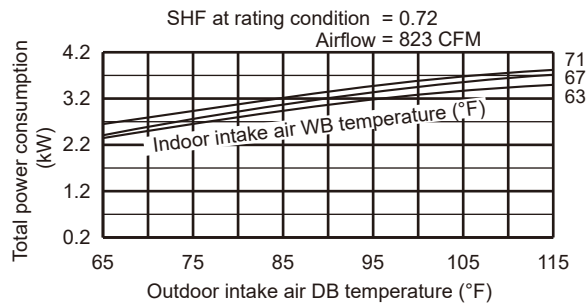

MUZ-GS36NA MUZ-GS36NAH MUY-GS36NA (208V)

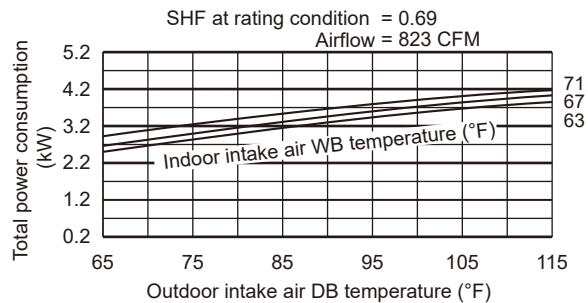

MUZ-GS36NA MUZ-GS36NAH MUY-GS36NA (230V)

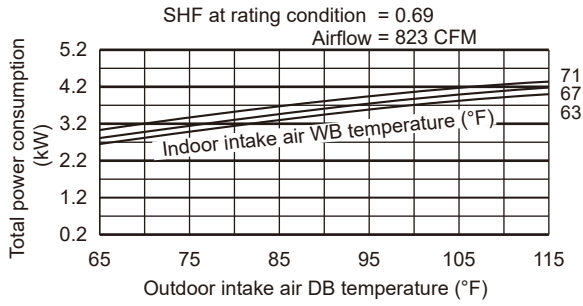

This value of frequency is not the same as the actual frequency in operating. Refer to 7-5 and 7-6 for the relationships between frequency and capacity.

Heating

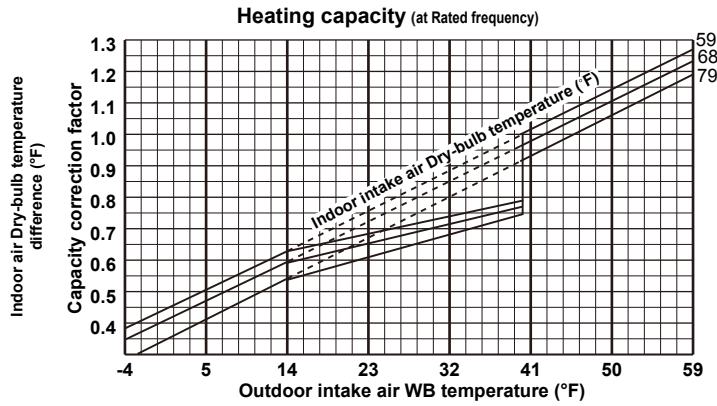

MUZ-GS30NA

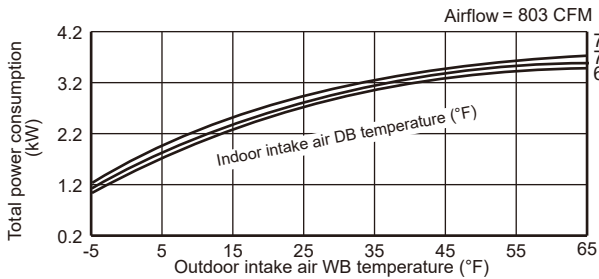

MUZ-GS30NAH

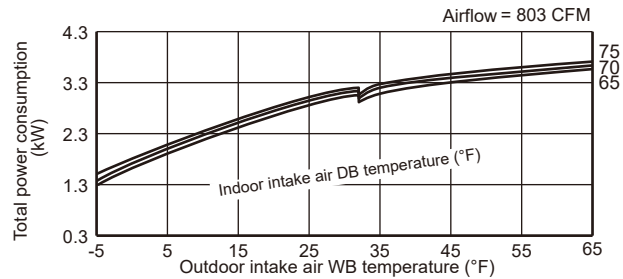

MUZ-GS36NA

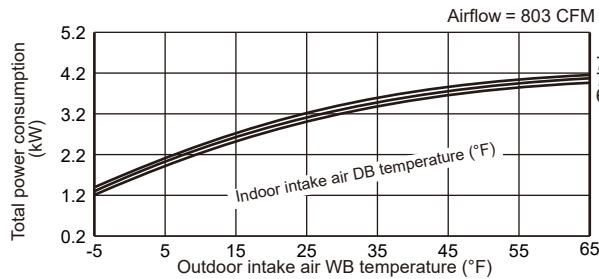

MUZ-GS36NAH

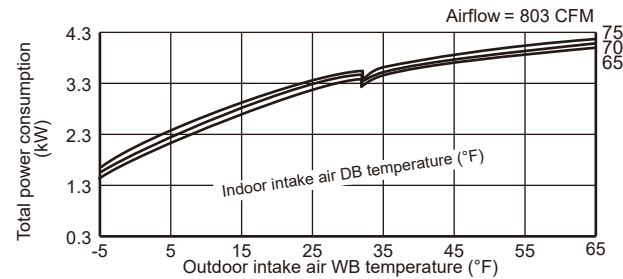

This value of frequency is not the same as the actual frequency in operating. Refer to 7-5 and 7-6 for the relationships between frequency and capacity.

7-3. CONDENSING PRESSURE

Cooling

Data are based on the condition of indoor humidity 50 %.

Air flow should be set to High speed.

MUZ-GS30NA MUZ-GS30NAH MUY-GS30NA

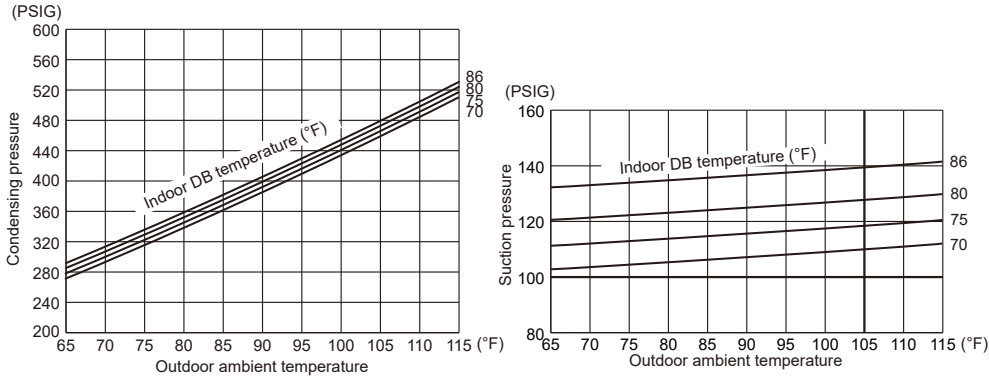

MUZ-GS36NA MUZ-GS36NAH MUY-GS36NA

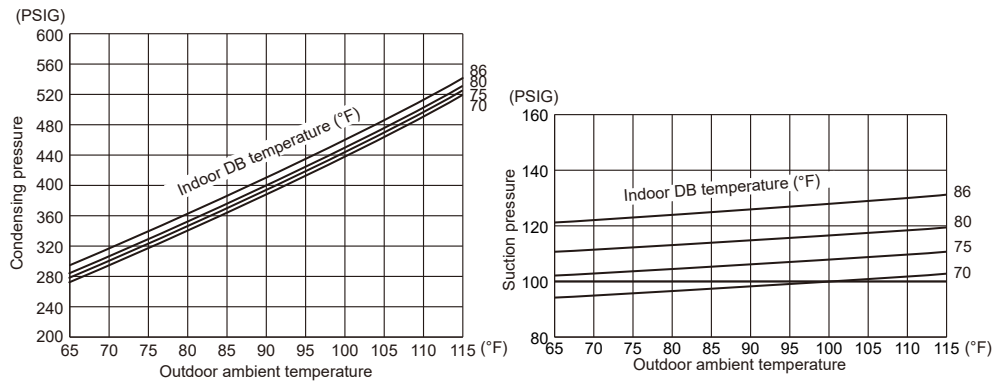

Heating

Data are based on the condition of outdoor humidity 75%.

Air flow should be set to High speed.

Data are for heating operation without any frost.

MUZ-GS30NA MUZ-GS30NAH

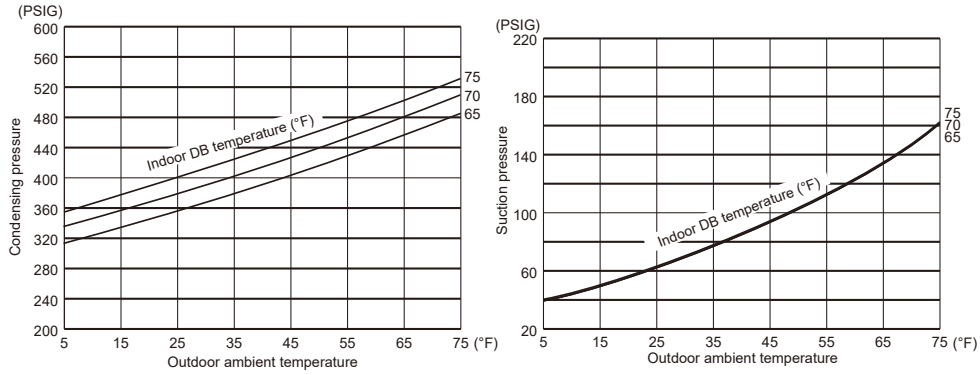

MUZ-GS36NA MUZ-GS36NAH

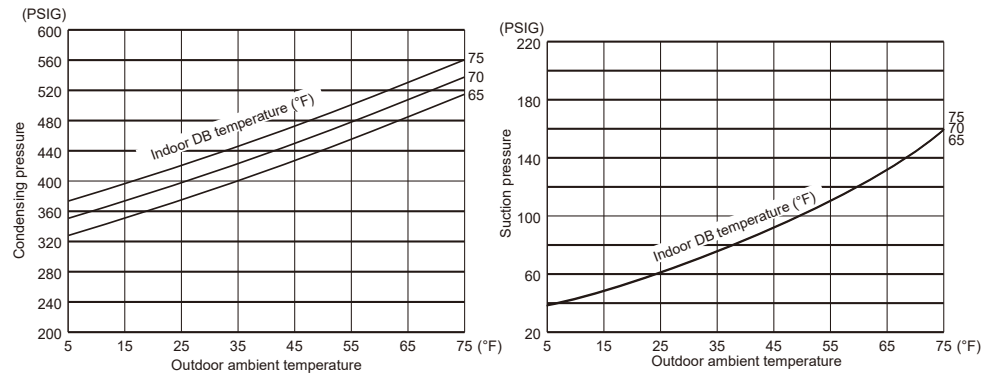

7-4. STANDARD OPERATION DATA

Model			MSZ-GS30NA MSY-GS30NA		MSZ-GS36NA MSY-GS36NA	
Item		Unit	Cooling	Heating	Cooling	Heating
Total	Capacity	Btu/h	30,700	32,600	32,000/33,200	35,200
	SHF	—	0.72	—	0.69	—
	Input	kW	3.32	3.34	3.63/3.77	3.74
	Rated frequency	Hz	78	82	92	89
Electrical circuit	Indoor unit		MSZ-GS30NA MSY-GS30NA		MSZ-GS36NA MSY-GS36NA	
	Power supply	V, phase, Hz	208/230, 1, 60			
	Input	kW	Cooling: 0.078 Heating: 0.055			
	Fan motor current	A	Cooling: 0.70/0.63 Heating: 0.52/0.47			
	Outdoor unit		MUZ-GS30NA MUZ-GS30NAH MUY-GS30NA		MUZ-GS36NA MUZ-GS36NAH MUY-GS36NA	
	Power supply	V, phase, Hz	208/230, 1, 60			
	Input	kW	3.242	3.285	3.552/3.692	3.685
	Comp. current	A	12.61/11.41	13.25/11.98	14.42/15.18	15.68/14.18
	Fan motor current	A	0.84/0.76	0.83/0.75	0.98/0.89	0.83/0.75
	Refrigerant circuit	Condensing pressure	PSIG	423	430	426
Suction pressure		PSIG	125	97	114	95
Discharge temperature		°F	175	180	182	185
Condensing temperature		°F	121	122	121	126
Suction temperature		°F	49	30	44	29
Comp. shell bottom temperature		°F	164	169	170	172
Ref. pipe length		ft.	25			
Refrigerant charge (R410A)			4 lb.			
Indoor unit	Intake air temperature	DB °F	80	70	80	70
		WB °F	67	60	67	60
	Discharge air temperature	DB °F	54	116	53	119
		WB °F	53	—	52	—
	Fan speed (High)	rpm	1,230	1,100	1,230	1,100
	Airflow (High)	CFM	823 (Wet)	803	823 (Wet)	803
Outdoor unit	Intake air temperature	DB °F	95	47	95	47
		WB °F	—	43	—	43
	Fan speed	rpm	810	800	900	800
	Airflow	CFM	1,974	1,950	2,191	1,950

7-5. CAPACITY AND INPUT CORRECTION BY INVERTER OUTPUT FREQUENCY

MUZ-GS30NA MUZ-GS30NAH MUY-GS30NA

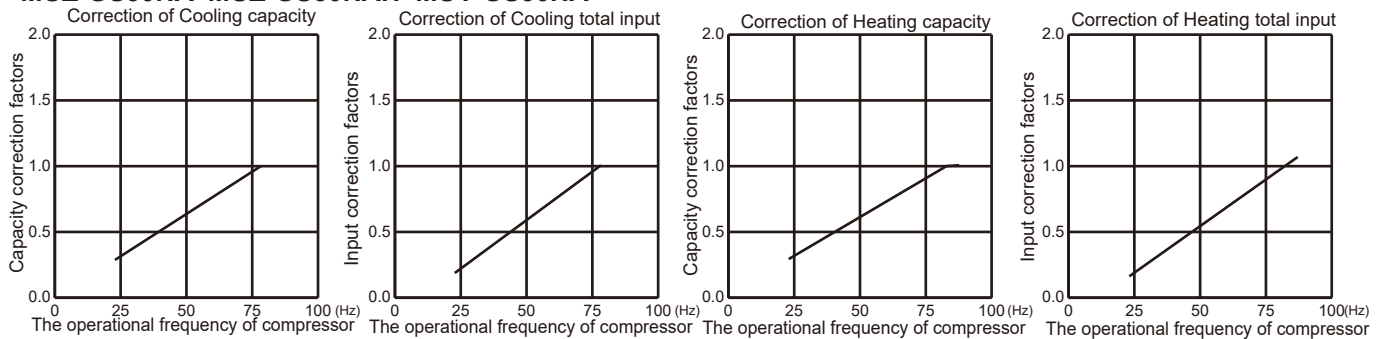

MUZ-GS36NA MUZ-GS36NAH MUY-GS36NA (208V)

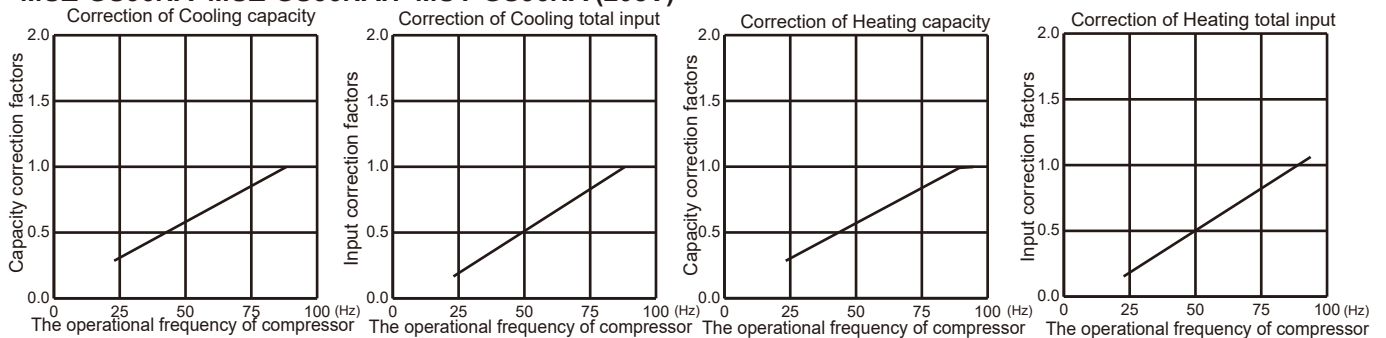

MUZ-GS36NA MUZ-GS36NAH MUY-GS36NA (230V)

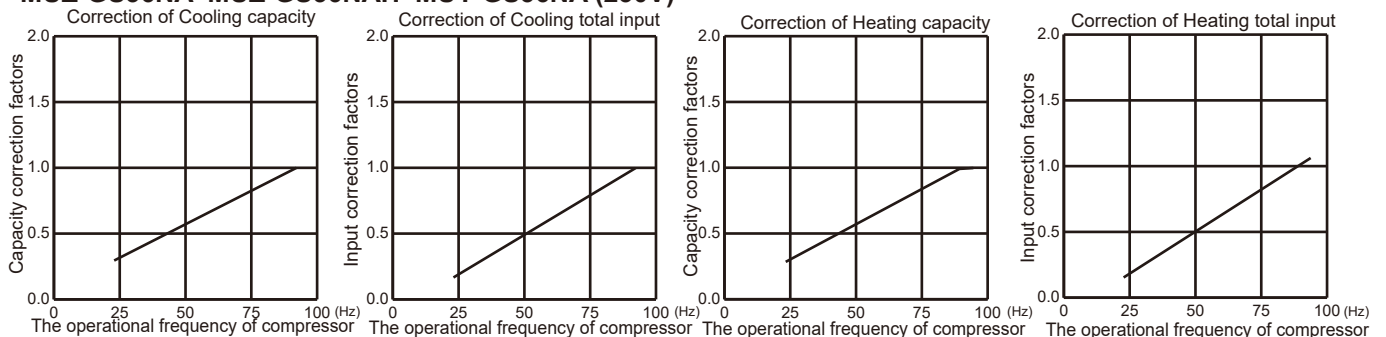

7-6. HOW TO OPERATE FIXED-FREQUENCY OPERATION (Test run operation)

1. Press the emergency operation switch to start COOL or HEAT mode (COOL: Press once, HEAT: Press twice).
2. Test run operation starts and continues to operate for 30 minutes.
3. Compressor operates at rated frequency in COOL mode or 58 Hz in HEAT mode.
4. Indoor fan operates at High speed.
5. After 30 minutes, test run operation finishes and EMERGENCY OPERATION starts (operation frequency of compressor varies).
6. To cancel test run operation (EMERGENCY OPERATION), press the emergency operation switch or any button on remote controller.

MUZ-GS30NA MUZ-GS30NAH MUZ-GS36NA MUZ-GS36NAH MUY-GS30NA MUY-GS36NA

8-1. OUTDOOR FAN MOTOR CONTROL

The fan motor turns ON/OFF, interlocking with the compressor.

[ON] The fan motor turns ON 5 seconds before the compressor starts up.

[OFF] The fan motor turns OFF 15 seconds after the compressor has stopped running.

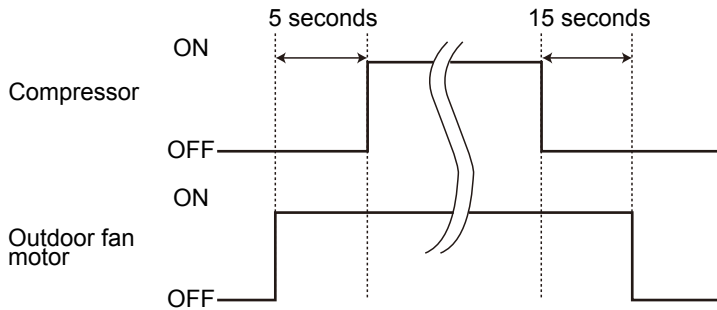

8-2. R.V. COIL CONTROL

Heating ON

Cooling OFF

Dry OFF

NOTE: The 4-way valve reverses for 5 seconds right before start-up of the compressor.

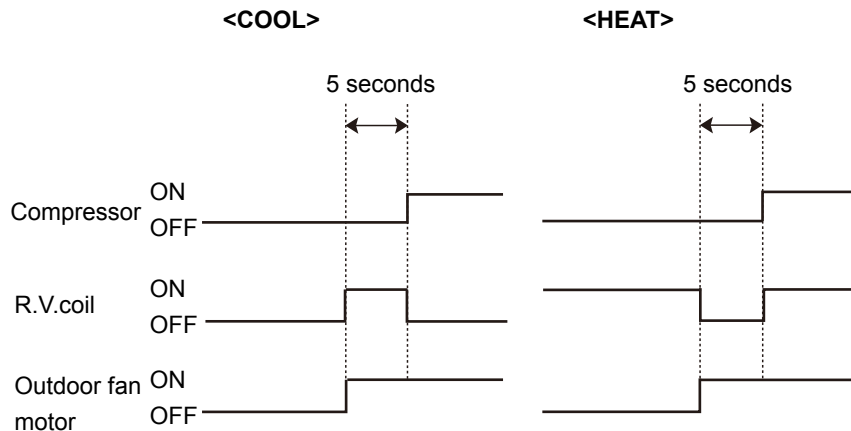

8-3. RELATION BETWEEN MAIN SENSOR AND ACTUATOR

Sensor	Purpose	Actuator					
		Compressor	LEV	Outdoor fan motor	R.V.coil	Indoor fan motor	Defrost heater *
Discharge temperature thermistor	Protection	○	○				
Indoor coil temperature thermistor	Cooling: Coil frost prevention	○					
	Heating: High pressure protection	○	○				
Defrost thermistor	Heating: Defrosting	○	○	○	○	○	
Fin temperature thermistor	Protection	○		○			
Ambient temperature thermistor	Cooling: Low ambient temperature operation	○	○	○			
	Heating: Defrosting (Heater)						○
Outdoor heat exchanger temperature thermistor	Cooling: Low ambient temperature operation	○	○	○			
	Cooling: High pressure protection	○	○	○			

* MUZ-GS•NAH only.

MUZ-GS30NA MUZ-GS30NAH MUZ-GS36NA MUZ-GS36NAH MUY-GS30NA MUY-GS36NA**9-1. CHANGE IN DEFROST SETTING****Changing defrost finish temperature**

<JS> To change the defrost finish temperature, cut/solder the JS wire of the outdoor inverter P.C. board (Refer to 10-6.1.).

Jumper		Defrost finish temperature
		MUZ-GS30/36NA MUZ-GS30/36NAH MUY-GS30/36NA
JS	Soldered (Initial setting)	50°F (10°C)
	None (Cut)	64°F (18°C)

9-2. PRE-HEAT CONTROL SETTING

Prolonged low load operation, in which the thermostat is OFF for a long time, at low outside temperature [32°F (0°C) or less] may cause the following troubles. To prevent those troubles, activate the pre-heat control.

- 1) If moisture gets into the refrigerant cycle and freezes, it may interfere the start-up of the compressor.
- 2) If liquid refrigerant collects in the compressor, a failure in the compressor may occur.

The pre-heat control turns ON when the compressor temperature is 68°F (20°C) or below. When the pre-heat control turns ON, the compressor is energized. (About 70 W)

Pre-heat control setting

<JK>

ON: To activate the pre-heat control, cut JK wire of the inverter P.C. board.

OFF: To deactivate the pre-heat control, solder JK wire of the inverter P.C. board.

(Refer to 10-6.1)

Jumper		Pre-heat control setting
		MUZ-GS30/36NA MUZ-GS30/36NAH MUY-GS30/36NA
JK	Soldered	Deactivated (Initial setting)
	Cut	Activated

NOTE: When the inverter P.C. board is replaced, check the jumper wires, and cut/solder them if necessary.

MUZ-GS30NA MUZ-GS30NAH MUZ-GS36NA MUZ-GS36NAH MUY-GS30NA MUY-GS36NA
10-1. CAUTIONS ON TROUBLESHOOTING
1. Before troubleshooting, check the following

- 1) Check the power supply voltage.
- 2) Check the indoor/outdoor connecting wire for miswiring.

2. Take care of the following during servicing

- 1) Before servicing the air conditioner, be sure to turn OFF the main unit first with the remote controller, then after confirming the horizontal vane is closed, turn off the breaker and/or disconnect the power plug.
- 2) Be sure to turn OFF the power supply before removing the front panel, the cabinet, the top panel, and the electronic control P.C. board.
- 3) When removing the electrical parts, be careful of the residual voltage of smoothing capacitor.
- 4) When removing the electronic control P.C. board, hold the edge of the board with care NOT to apply stress on the components.
- 5) When connecting or disconnecting the connectors, hold the connector housing. DO NOT pull the lead wires.

<Incorrect>

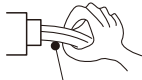

Lead wiring

<Correct>



Connector housing

3. Troubleshooting procedure

- 1) Check if the OPERATION INDICATOR lamp on the indoor unit is blinking on and off to indicate an abnormality. To make sure, check how many times the OPERATION INDICATOR lamp is blinking on and off before starting service work.
- 2) Before servicing, verify that all connectors and terminals are connected properly.
- 3) When the electronic control P.C. board seems to be defective, check for disconnection of the copper foil pattern and burnt or discolored components.
- 4) Refer to 10-2 and 10-3.

10-2. FAILURE MODE RECALL FUNCTION

Outline of the function

This air conditioner can memorize the abnormal condition which has occurred once.

Even though LED indication listed on the troubleshooting check table (10-3.) disappears, the memorized failure details can be recalled.

1. Flow chart of failure mode recall function for the indoor/outdoor unit

Operational procedure

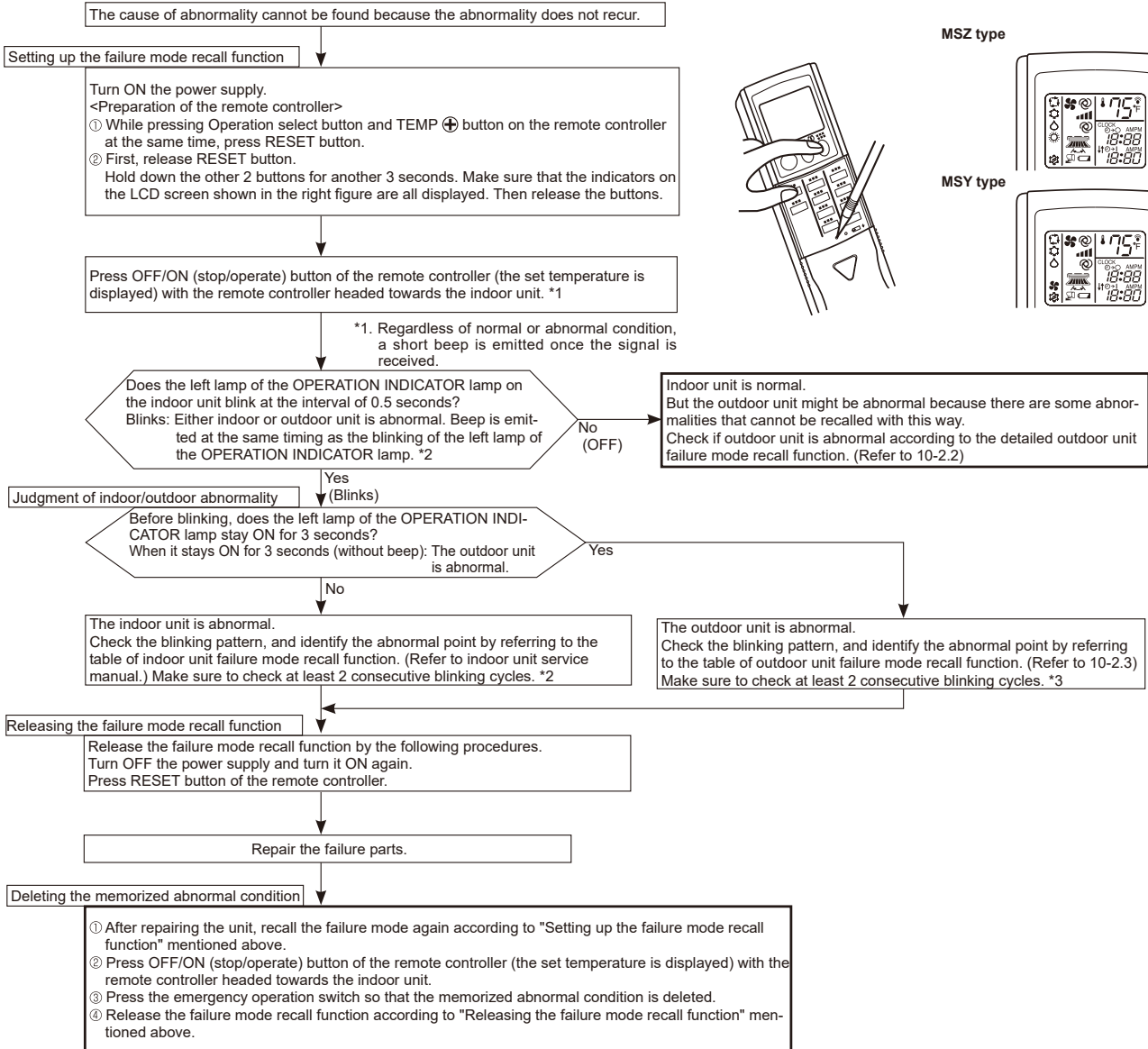

NOTE: 1. Make sure to release the failure mode recall function after it is set up, otherwise the unit cannot operate properly.

2. If the abnormal condition is not deleted from the memory, the last abnormal condition is kept memorized.

*2. Blinking pattern when the indoor unit is abnormal:

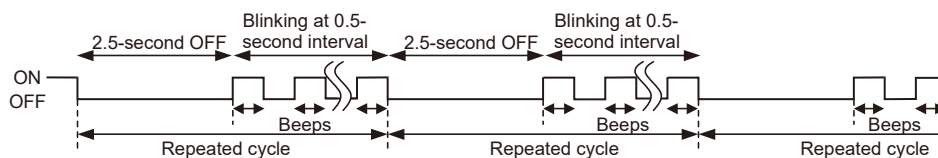

*3. Blinking pattern when the outdoor unit is abnormal:

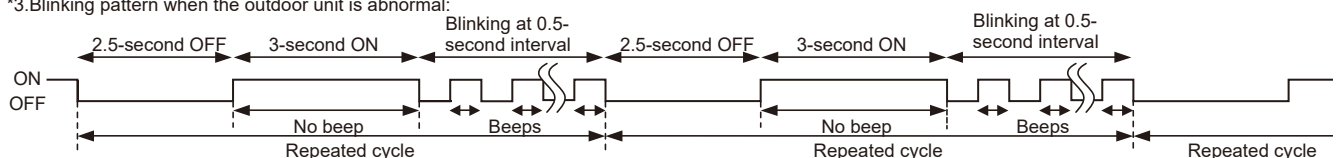

2. Flow chart of the detailed outdoor unit failure mode recall function

Operational procedure

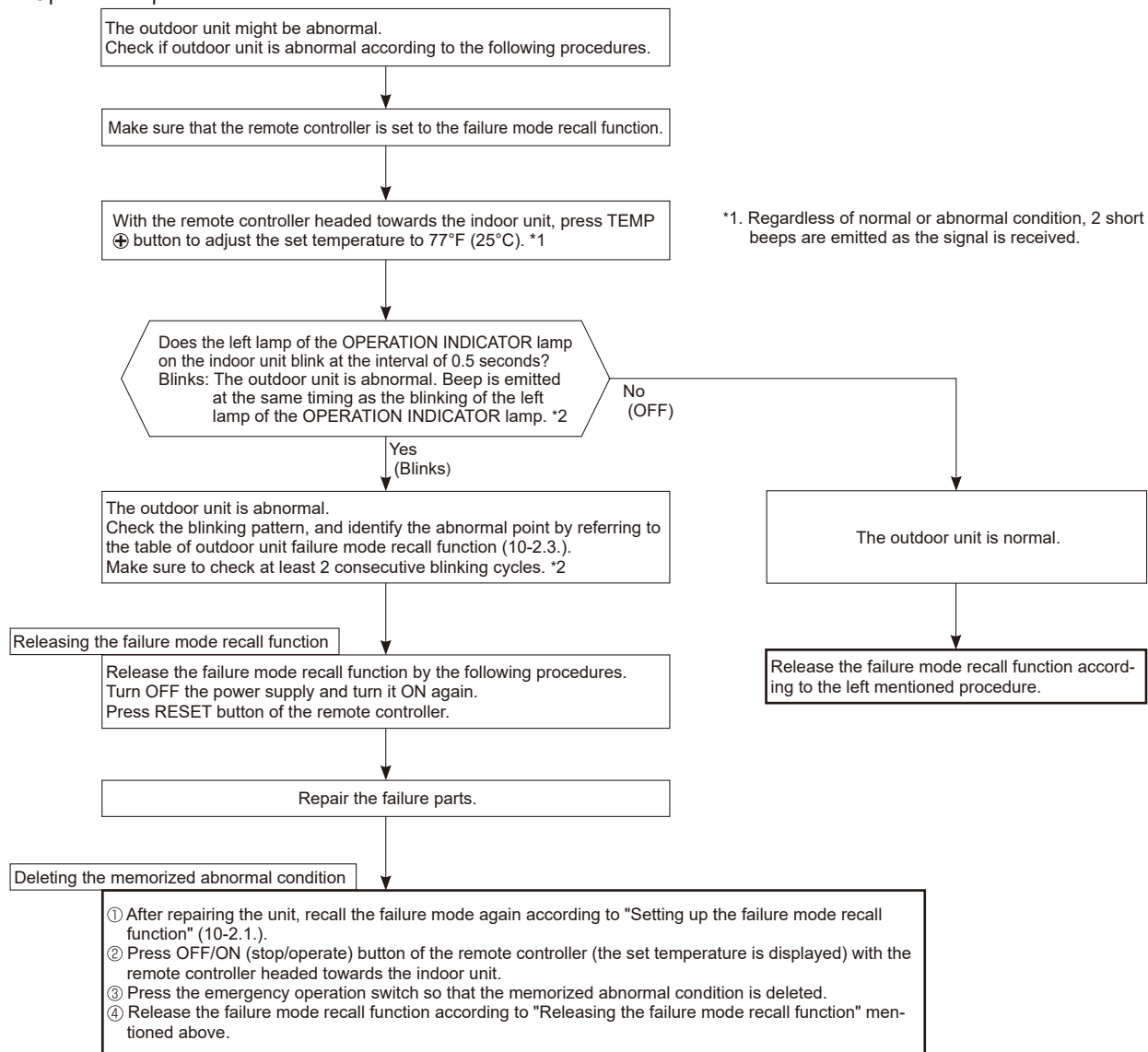

NOTE: 1. Make sure to release the failure mode recall function after it is set up, otherwise the unit cannot operate properly.
2. If the abnormal condition is not deleted from the memory, the last abnormal condition is kept memorized.

*2. Blinking pattern when outdoor unit is abnormal:

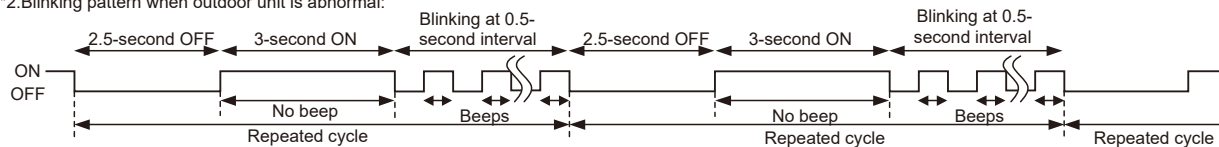

NOTE: Blinking patterns of this mode differ from the ones of TROUBLESHOOTING CHECK TABLE (10-3.).

3. Table of outdoor unit failure mode recall function

The left lamp of the OPERATION INDICATOR lamp (Indoor unit)	Abnormal point (Failure mode/protection)	LED indication (Outdoor P.C. board)	Condition	Remedy	Indoor/outdoor unit failure mode recall function	Outdoor unit failure mode recall function
OFF	None (Normal)	—	—	—	—	—
1-time blink 2.5 seconds OFF	Indoor/outdoor communication, receiving error	—	Any signals from the inverter P.C. board cannot be received normally for 3 minutes.	•Refer to 10-5. ㉞ How to check miswiring and serial signal error.	○	○
	Indoor/outdoor communication, receiving error	—	Although the inverter P.C. board sends signal "0", signal "1" has been received 30 consecutive times.	•Refer to 10-5. ㉞ How to check miswiring and serial signal error.		
2-time blink 2.5 seconds OFF	Outdoor power system	—	Overcurrent protection cut-out operates 3 consecutive times within 1 minute after the compressor gets started.	•Reconnect connectors. •Refer to 10-5. ㉞ How to check inverter/compressor". •Check stop valve.	○	○
3-time blink 2.5 seconds OFF	Discharge temperature thermistor	1-time blink every 2.5 seconds	Thermistor shorts or opens during compressor running.	•Refer to 10-5. ㉞ "Check of outdoor thermistors". Defective outdoor thermistors can be identified by checking the blinking pattern of LED.	○	○
	Defrost thermistor					
	Fin temperature thermistor	3-time blink 2.5 seconds OFF				
	P.C. board temperature thermistor	4-time blink 2.5 seconds OFF				
	Ambient temperature thermistor	2-time blink 2.5 seconds OFF				
Outdoor heat exchanger temperature thermistor	—					
4-time blink 2.5 seconds OFF	Overcurrent	11-time blink 2.5 seconds OFF	Large current flows into the power module (IC700).	•Reconnect compressor connector. •Refer to 10-5. ㉞ How to check inverter/compressor". •Check stop valve.	—	○
	Compressor synchronous abnormality (Compressor start-up failure protection)	12-time blink 2.5 seconds OFF	Waveform of compressor current is distorted.	•Reconnect compressor connector. •Refer to 10-5. ㉞ How to check inverter/compressor".	—	○
5-time blink 2.5 seconds OFF	Discharge temperature	—	Temperature of discharge temperature thermistor exceeds 241°F (116°C), compressor stops. Compressor can restart if discharge temperature thermistor reads 212°F (100°C) or less 3 minutes later.	•Check refrigerant circuit and refrigerant amount. •Refer to 10-5. ㉞ Check of LEV".	—	○
6-time blink 2.5 seconds OFF	High pressure	—	Temperature indoor coil thermistor exceeds 158°F (70°C) in HEAT mode. Temperature defrost thermistor exceeds 158°F (70°C) in COOL mode.	•Check refrigerant circuit and refrigerant amount. •Check stop valve.	—	○
7-time blink 2.5 seconds OFF	Fin temperature/ P.C. board temperature	7-time blink 2.5 seconds OFF	Temperature of the fin temperature thermistor on the inverter P.C. board exceeds 167 - 176°F (75 - 80°C), or temperature of P.C. board temperature thermistor on the inverter P.C. board exceeds 158 - 167°F (70 - 75°C).	•Check around outdoor unit. •Check outdoor unit air passage. •Refer to 10-5. ㉞ Check of outdoor fan motor".	—	○
8-time blink 2.5 seconds OFF	Outdoor fan motor	—	Outdoor fan has stopped 3 times in a row within 30 seconds after outdoor fan start-up.	•Refer to 10-5. ㉞ Check of outdoor fan motor". Refer to 10-5. ㉞ Check of inverter P.C. board".	—	○
9-time blink 2.5 seconds OFF	Nonvolatile memory data	5-time blink 2.5 seconds OFF	Nonvolatile memory data cannot be read properly.	•Replace the inverter P.C. board.	○	○
	Power module (IC700)	6-time blink 2.5 seconds OFF	The interface short circuit occurs in the output of the power module (IC700). The compressor winding shorts circuit.	•Refer to 10-5. ㉞ How to check inverter/compressor".	—	

NOTE: Blinking patterns of this mode differ from the ones of TROUBLESHOOTING CHECK TABLE (10-3.).

The left lamp of the OPERATION INDICATOR lamp (Indoor unit)	Abnormal point (Failure mode/protection)	LED indication (Outdoor P.C. board)	Condition	Remedy	Indoor/outdoor unit failure mode recall function	Outdoor unit failure mode recall function
10-time blink 2.5 seconds OFF	Discharge temperature	—	Temperature of discharge temperature thermistor has been 122°F (50°C) or less for 20 minutes.	<ul style="list-style-type: none"> Refer to 10-5.Ⓢ"Check of LEV". Check refrigerant circuit and refrigerant amount. 	—	○
11-time blink 2.5 seconds OFF	Bus-bar voltage (DC)	8-time blink 2.5 seconds OFF	Bus-bar voltage of inverter cannot be detected normally.	<ul style="list-style-type: none"> Refer to 10-5.Ⓢ"How to check inverter/compressor". 	—	○
	Each phase current of compressor	9-time blink 2.5 seconds OFF	Each phase current of compressor cannot be detected normally.			
14-time blink 2.5 seconds OFF *1	Stop valve (Closed valve)	14-time blink 2.5 seconds OFF	<ul style="list-style-type: none"> Closed valve is detected by compressor current. An abnormality of the indoor thermistors, the defrost thermistor or ambient temperature thermistor is detected. 	<ul style="list-style-type: none"> Check stop valve. Refer to "TEST POINT DIAGRAM AND VOLTAGE" on the service manual of indoor and outdoor unit for the characteristics of the thermistors. (Do not start the operation again without repair to prevent hazards.) 	○	○
	4-way valve/ Pipe temperature	16-time blink 2.5 seconds OFF	<ul style="list-style-type: none"> The 4-way valve does not work properly. The indoor coil thermistor detects an abnormal temperature. An abnormality of the indoor thermistor is detected. 	<ul style="list-style-type: none"> Check the 4-way valve. Replace the inverter P.C. board. Refer to "TEST POINT DIAGRAM AND VOLTAGE" on the service manual of indoor and outdoor unit for the characteristics of the thermistors. (Do not start the operation again without repair to prevent hazards.) 		
16-time blink 2.5 seconds OFF *1	Outdoor refrigerant system abnormality	1-time blink 2.5 seconds OFF	<ul style="list-style-type: none"> A closed valve and air trapped in the refrigerant circuit are detected based on the temperature sensed by the indoor and outdoor thermistors and the current of the compressor. An abnormality of the indoor thermistors, the defrost thermistor or ambient temperature thermistor is detected. 	<ul style="list-style-type: none"> Check for a gas leak in a connecting piping etc. Check the stop valve. Refer to 10-5.Ⓢ "Check of outdoor refrigerant circuit". Refer to "TEST POINT DIAGRAM AND VOLTAGE" on the service manual of indoor and outdoor unit for the characteristics of the thermistors. (Do not start the operation again without repair to prevent hazards.) 	○	○

*1 There is possibility that diesel explosion may occur due to the air mixed in the refrigerant circuit.

First, ensure that there are no leakage points on the valves, flare connections, etc. that allow the air to flow into the refrigerant circuit, or no blockage points (e.g. clogged or closed valves) in the refrigerant circuit that cause an increase in pressure.

If there is no abnormal point like above and the system operates cooling and heating modes normally, the indoor thermistor might have a problem, resulting in false detection.

Check both the indoor coil thermistor and the room temperature thermistor, and replace faulty thermistor(s), if any.

NOTE: Do not start the operation again without repair to prevent hazards.

10-3. TROUBLESHOOTING CHECK TABLE

No.	Symptom	LED indication	Abnormal point/ Condition	Condition	Remedy
1	Outdoor unit does not operate.	1-time blink every 2.5 seconds	Outdoor power system	Overcurrent protection cut-out operates 3 consecutive times within 1 minute after the compressor gets started.	<ul style="list-style-type: none"> •Reconnect connector of compressor. •Refer to 10-5.Ⓐ "How to check inverter/compressor". •Check stop valve.
2			Outdoor thermistors	Discharge temperature thermistor, fin temperature thermistor, defrost thermistor, P.C. board temperature thermistor, outdoor heat exchanger temperature thermistor or ambient temperature thermistor shorts or opens during compressor running.	•Refer to 10-5.Ⓒ "Check of outdoor thermistors".
3			Outdoor control system	Nonvolatile memory data cannot be read properly. (The left lamp of the OPERATION INDICATOR lamp on the indoor unit lights up or blinks 7-time.)	•Replace inverter P.C. board.
4		6-time blink 2.5 seconds OFF	Serial signal	The communication fails between the indoor and outdoor unit for 3 minutes.	•Refer to 10-5.Ⓜ "How to check miswiring and serial signal error.
5		11-time blink 2.5 seconds OFF	Stop valve/ Closed valve	Closed valve is detected by compressor current.	•Check stop valve.
6		16-time blink 2.5 seconds OFF	4-way valve/ Pipe temperature	The 4-way valve does not work properly. The indoor coil thermistor detects an abnormal temperature.	<ul style="list-style-type: none"> •Refer to 10-5.Ⓣ "Check of R.V. coil". •Replace the inverter P.C. board.
7		17-time blink 2.5 seconds OFF	Outdoor refrigerant system abnormality	A closed valve and air trapped in the refrigerant circuit are detected based on the temperature sensed by the indoor and outdoor thermistors and the current of the compressor.	<ul style="list-style-type: none"> •Check for a gas leak in a connecting piping etc. •Check the stop valve. •Refer to 10-5.Ⓢ "Check of outdoor refrigerant circuit".
8	'Outdoor unit stops and restarts 3 minutes later' is repeated.	2-time blink 2.5 seconds OFF	Overcurrent protection	Large current flows into the power module (IC700).	<ul style="list-style-type: none"> •Reconnect connector of compressor. •Refer to 10-5.Ⓐ "How to check inverter/compressor". •Check stop valve.
9		3-time blink 2.5 seconds OFF	Discharge temperature overheat protection	Temperature of discharge temperature thermistor exceeds 241°F (116°C), compressor stops. Compressor can restart if discharge temperature thermistor reads 212°F (100°C) or less 3 minutes later.	<ul style="list-style-type: none"> •Check refrigerant circuit and refrigerant amount. •Refer to 10-5.Ⓚ "Check of LEV".
10		4-time blink 2.5 seconds OFF	Fin temperature /P.C. board temperature thermistor overheat protection	Temperature of the fin temperature thermistor on the heat sink exceeds 167 - 176°F (75 - 80°C) or temperature of P.C. board temperature thermistor on the inverter P.C.board exceeds 158 - 167°F (70 - 75°C).	<ul style="list-style-type: none"> •Check around outdoor unit. •Check outdoor unit air passage. •Refer to 10-5.Ⓛ "Check of outdoor fan motor".
11		5-time blink 2.5 seconds OFF	High pressure protection	Indoor coil thermistor exceeds 158°F (70°C) in HEAT mode. Defrost thermistor exceeds 158°F (70°C) in COOL mode.	<ul style="list-style-type: none"> •Check refrigerant circuit and refrigerant amount. •Check stop valve.
12		8-time blink 2.5 seconds OFF	Compressor synchronous abnormality	The waveform of compressor current is distorted.	<ul style="list-style-type: none"> •Reconnect connector of compressor. •Refer to 10-5.Ⓐ "How to check inverter/compressor".
13		10-time blink 2.5 seconds OFF	Outdoor fan motor	Outdoor fan has stopped 3 times in a row within 30 seconds after outdoor fan start-up.	<ul style="list-style-type: none"> •Refer to 10-5.Ⓛ "Check of outdoor fan motor. •Refer to 10-5.Ⓛ "Check of inverter P.C. board.
14		12-time blink 2.5 seconds OFF	Each phase current of compressor	Each phase current of compressor cannot be detected normally.	•Refer to 10-5.Ⓐ "How to check inverter/compressor".
15		13-time blink 2.5 seconds OFF	Bus-bar voltage (DC)	Bus-bar voltage of inverter cannot be detected normally.	<ul style="list-style-type: none"> •It occurs with following case. Instantaneous power voltage drop. (Short time power failure) •Refer to 10-5.Ⓢ "Check of power supply". •Refer to 10-5.Ⓐ "How to check inverter/compressor".

NOTE: 1. The location of LED is illustrated at the right figure. Refer to 10-6.1.
2. LED is lit during normal operation.

The blinking frequency shows the number of times the LED blinks after every 2.5-second OFF.
(Example) When the blinking frequency is "2".

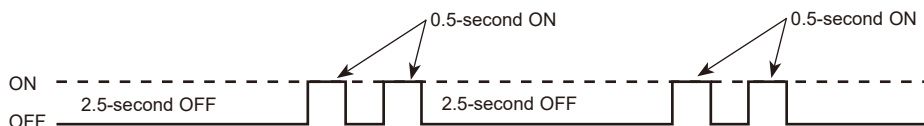

Inverter P.C. board
MUZ-GS30/36NA
MUZ-GS30/36NAH
MUY-GS30/36NA

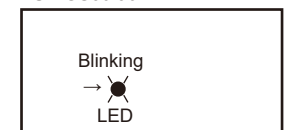

No.	Symptom	LED indication	Abnormal point/ Condition	Condition	Remedy
16	Outdoor unit operates.	1-time blink 2.5 seconds OFF	Frequency drop by current protection	Current from power outlet is nearing breaker capacity.	<ul style="list-style-type: none"> The unit is normal, but check the following. •Check if indoor filters are clogged. •Check if refrigerant is short. •Check if indoor/outdoor unit air circulation is short cycled.
17		3-time blink 2.5 seconds OFF	Frequency drop by high pressure protection	Temperature of indoor coil thermistor exceeds 131 °F (55°C) in HEAT mode, compressor frequency lowers.	
			Frequency drop by defrosting in COOL mode	Indoor coil thermistor reads 46°F (8°C) or less in COOL mode, compressor frequency lowers.	
18	4-time blink 2.5 seconds OFF	Frequency drop by discharge temperature protection	Temperature of discharge temperature thermistor exceeds 232°F (111°C), compressor frequency lowers.	<ul style="list-style-type: none"> •Check refrigerant circuit and refrigerant amount. •Refer to 10-5.Ⓢ "Check of LEV". •Refer to 10-5.Ⓣ "Check of outdoor thermistors". 	
19	Outdoor unit operates.	7-time blink 2.5 seconds OFF	Low discharge temperature protection	Temperature of discharge temperature thermistor has been 122°F (50°C) or less for 20 minutes.	<ul style="list-style-type: none"> •Refer to 10-5.Ⓢ "Check of LEV". •Check refrigerant circuit and refrigerant amount.
20		8-time blink 2.5 seconds OFF	Zero cross detecting circuit	Zero cross signal cannot be detected.	
			9-time blink 2.5 seconds OFF	Inverter check mode	
21				<ul style="list-style-type: none"> •It occurs with following cases. <ul style="list-style-type: none"> 1 Instantaneous power voltage drop. (Short time power failure) 2 Distortion of primary voltage •Refer to 10-5.Ⓣ "Check of power supply". 	

NOTE: 1. The location of LED is illustrated at the right figure. Refer to 10-6.1.
2. LED is lit during normal operation.

The blinking frequency shows the number of times the LED blinks after every 2.5-second OFF.
(Example) When the blinking frequency is "2".

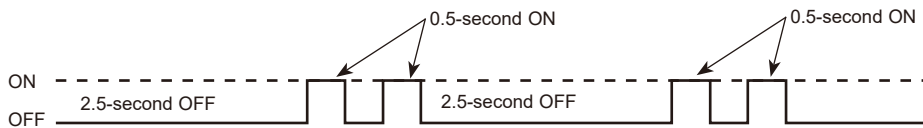

Inverter P.C. board
MUZ-GS30/36NA
MUZ-GS30/36NAH
MUY-GS30/36NA

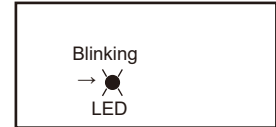

10-4. TROUBLESHOOTING CRITERION OF MAIN PARTS

MUZ-GS30NA MUZ-GS30NAH MUZ-GS36NA MUZ-GS36NAH MUY-GS30NA MUY-GS36NA

Part name	Check method and criterion	Figure							
Defrost thermistor (RT61) Fin temperature thermistor (RT64) Ambient temperature thermistor (RT65) Outdoor heat exchanger temperature thermistor (RT68)	Measure the resistance with a tester. Refer to 10-6. "Test point diagram and voltage", 1. "Inverter P.C. board", for the chart of thermistor.								
Discharge temperature thermistor (RT62)	Measure the resistance with a tester. Before measurement, hold the thermistor with your hands to warm it up. Refer to 10-6. "Test point diagram and voltage", 1. "Inverter P.C. board", for the chart of thermistor.								
Compressor	Measure the resistance between terminals using a tester. [Temperature: 14 - 104°F (-10 - 40°C)] <table border="1" style="margin-left: auto; margin-right: auto;"> <tr> <td></td> <td style="text-align: center;">Normal (Ω)</td> </tr> <tr> <td></td> <td style="text-align: center;">MUZ-GS30/36 MUY-GS30/36</td> </tr> <tr> <td>U-V U-W V-W</td> <td style="text-align: center;">1.38 - 1.87</td> </tr> </table>			Normal (Ω)		MUZ-GS30/36 MUY-GS30/36	U-V U-W V-W	1.38 - 1.87	
	Normal (Ω)								
	MUZ-GS30/36 MUY-GS30/36								
U-V U-W V-W	1.38 - 1.87								
Outdoor fan motor	Measure the resistance between lead wires using a tester. [Temperature: 14 - 104°F (-10 - 40°C)] <table border="1" style="margin-left: auto; margin-right: auto;"> <tr> <td>Color of lead wire</td> <td style="text-align: center;">Normal (Ω)</td> </tr> <tr> <td></td> <td style="text-align: center;">MUZ-GS30/36 MUY-GS30/36</td> </tr> <tr> <td>RED - BLK BLK - WHT WHT - RED</td> <td style="text-align: center;">8 - 10</td> </tr> </table>	Color of lead wire	Normal (Ω)		MUZ-GS30/36 MUY-GS30/36	RED - BLK BLK - WHT WHT - RED	8 - 10		
Color of lead wire	Normal (Ω)								
	MUZ-GS30/36 MUY-GS30/36								
RED - BLK BLK - WHT WHT - RED	8 - 10								
R. V. coil (21S4)	Measure the resistance using a tester. [Temperature: 14 - 104°F (-10 - 40°C)] <table border="1" style="margin-left: auto; margin-right: auto;"> <tr> <td style="text-align: center;">Normal (kΩ)</td> </tr> <tr> <td style="text-align: center;">0.97 - 1.38</td> </tr> </table>	Normal (kΩ)	0.97 - 1.38						
Normal (kΩ)									
0.97 - 1.38									
Expansion valve coil (LEV)	Measure the resistance using a tester. [Temperature: 14 - 104°F (-10 - 40°C)] <table border="1" style="margin-left: auto; margin-right: auto;"> <tr> <td>Color of lead wire</td> <td style="text-align: center;">Normal (Ω)</td> </tr> <tr> <td>RED - ORN</td> <td rowspan="4" style="text-align: center;">37 - 54</td> </tr> <tr> <td>RED - WHT</td> </tr> <tr> <td>RED - BLU</td> </tr> <tr> <td>RED - YLW</td> </tr> </table>	Color of lead wire	Normal (Ω)	RED - ORN	37 - 54	RED - WHT	RED - BLU	RED - YLW	
Color of lead wire	Normal (Ω)								
RED - ORN	37 - 54								
RED - WHT									
RED - BLU									
RED - YLW									
Defrost heater	Measure the resistance using a tester. [Temperature: 14 - 104°F (-10 - 40°C)] <table border="1" style="margin-left: auto; margin-right: auto;"> <tr> <td style="text-align: center;">Normal (Ω)</td> </tr> <tr> <td style="text-align: center;">MUZ-GS30/36NAH</td> </tr> <tr> <td style="text-align: center;">376 - 461</td> </tr> </table>	Normal (Ω)	MUZ-GS30/36NAH	376 - 461					
Normal (Ω)									
MUZ-GS30/36NAH									
376 - 461									

10-5. TROUBLESHOOTING FLOW

A How to check inverter/compressor

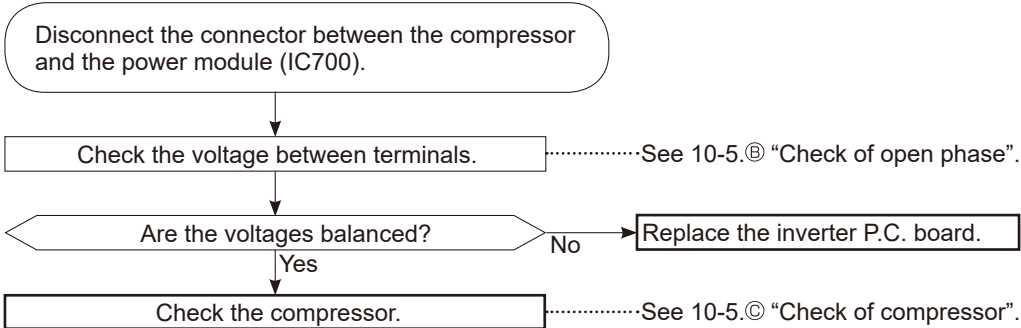

B Check of open phase

- With the connector between the compressor and the power module (IC700) disconnected, activate the inverter and check if the inverter is normal by measuring **the voltage balance** between the terminals.

Output voltage is 50 - 130 V. (The voltage may differ according to the tester.)

<< Operation method >>

Start cooling or heating operation by pressing the emergency operation switch on the indoor unit. (TEST RUN OPERATION: Refer to 7-6.)

<< Measurement point >>

At 3 points

BLK (U)-WHT (V)

BLK (U)-RED (W)

WHT(V)-RED (W)

*Measure AC voltage between the lead wires at 3 points.

NOTE: 1. Output voltage varies according to power supply voltage.

2. Measure the voltage by analog type tester.

3. During this check, LED of the inverter P.C. board blinks 9 times. (Refer to 10-6.1.)

C Check of compressor

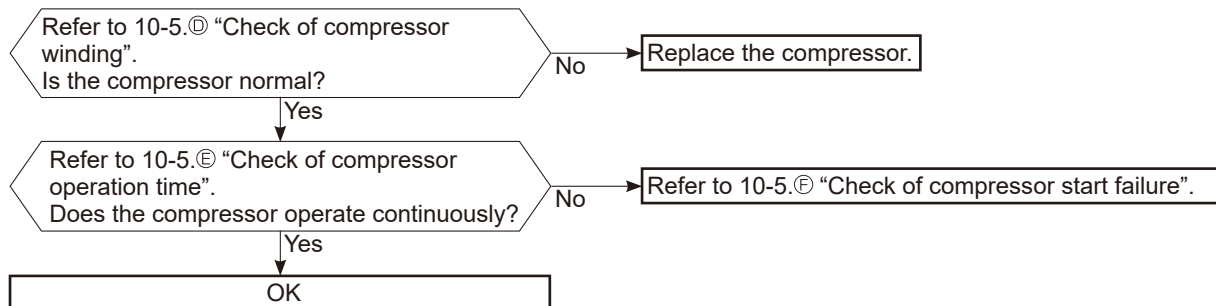

D Check of compressor winding

- Disconnect the connector between the compressor and the power module (IC700), and measure the resistance between the compressor terminals.

<<Measurement point>>

At 3 points

BLK-WHT

BLK-RED

WHT-RED

*Measure the resistance between the lead wires at 3 points.

<<Judgement>>

Refer to 10-4.

0 [Ω] Abnormal [short]

Infinite [Ω] Abnormal [open]

NOTE: Be sure to zero the ohmmeter before measurement.

E Check of compressor operation time

- Connect the compressor and activate the inverter. Then measure the time until the inverter stops due to overcurrent.

<<Operation method>>

Start heating or cooling operation by pressing the emergency operation switch on the indoor unit. (TEST RUN OPERATION: Refer to 7-6.)

<<Measurement>>

Measure the time from the start of compressor to the stop of compressor due to overcurrent.

<<Judgement>>

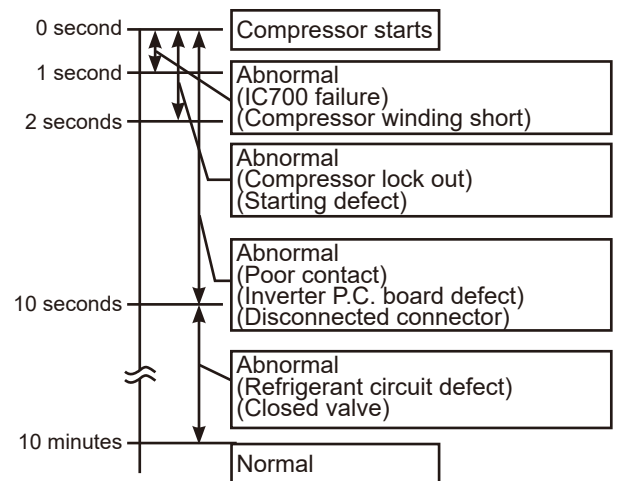

F Check of compressor start failure

Confirm that ①~④ is normal.

• Electrical circuit check

①. Contact of the compressor connector

②. Output voltage of inverter P.C. board and balance of them (See 10-5.⑥)

③. Direct current voltage between IC700(P) and (N) on the inverter P.C. board

④. Voltage between outdoor terminal block S1-S2

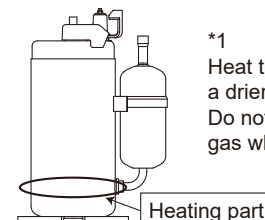
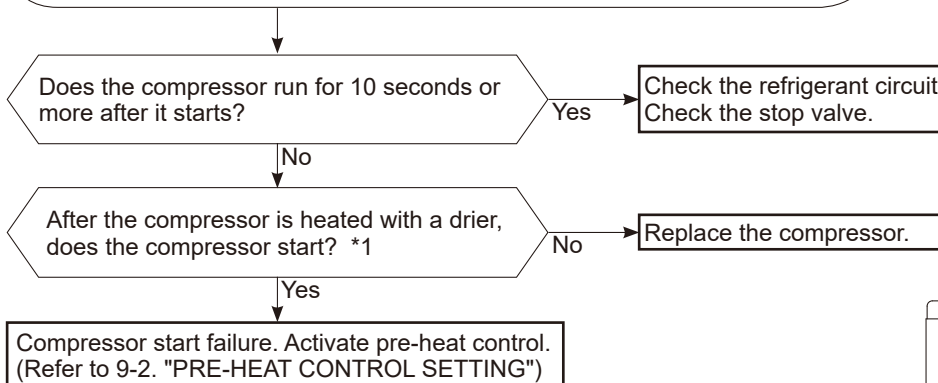

*1 Heat the compressor with a drier for about 20 minutes. Do not recover refrigerant gas while heating.

Ⓒ Check of outdoor thermistors

Disconnect the connector of thermistor in the inverter P.C. board (see below table), and measure the resistance of thermistor.

Is the resistance of thermistor normal?
(Refer to 10-6.1.)

No

Replace the thermistor except RT64.
When RT64 is abnormal, replace the inverter P.C. board.

Yes

Reconnect the connector of thermistor.
Turn ON the power supply and press the emergency operation switch.

Does the unit operate for 10 minutes or more
without showing thermistor abnormality?

No

Replace the inverter P.C. board.

Yes

OK
(Cause is poor contact.)

MUZ-GS30/36 MUY-GS30/36

Thermistor	Symbol	Connector, Pin No.	Board
Defrost	RT61	Between CN671 pin1 and pin2	Inverter P.C. board
Discharge temperature	RT62	Between CN671 pin3 and pin4	
Fin temperature	RT64	Between CN673 pin1 and pin2	
Ambient temperature	RT65	Between CN672 pin1 and pin2	
Outdoor heat exchanger temperature	RT68	Between CN671 pin5 and pin6	

H Check of R.V. coil

MUZ-GS30/36

- * First of all, measure the resistance of R.V. coil to check if the coil is defective. Refer to 10-4.
- * In case CN602 is disconnected or R.V. coil is open, voltage is generated between the terminal pins of the connector although no signal is being transmitted to R.V. coil.
Check if CN602 is connected.

Unit operates in COOL mode even if it is set to HEAT mode.

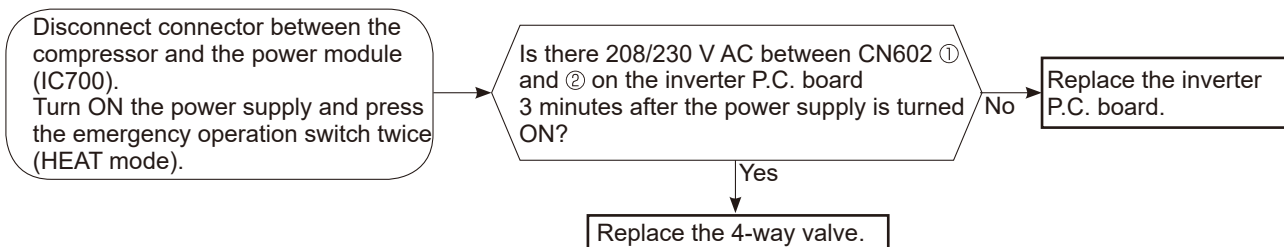

Unit operates in HEAT mode even if it is set to COOL mode.

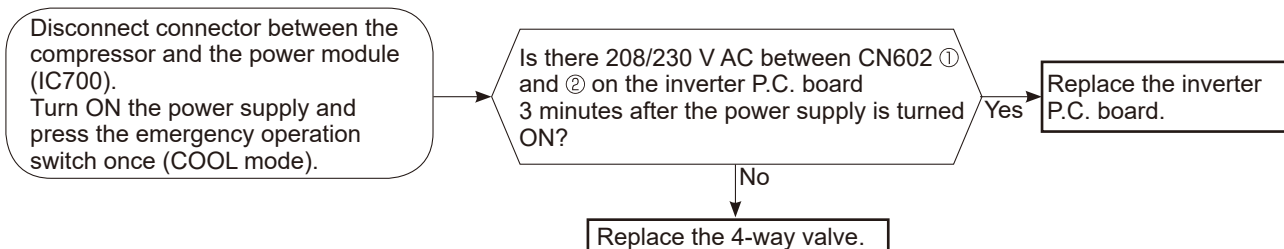

① Check of outdoor fan motor

Disconnect the connectors CN931 and CN932 from the inverter P.C. board.
Check the connection between the connector CN931 and CN932.

Is the resistance between each terminal of outdoor fan motor normal?
(Refer to 10-4.)

Yes

Disconnect CN932 from the inverter P.C. board, and turn on the power supply.

Rotate the outdoor fan motor manually and measure the voltage of CN931.
Between 1(+) and 5(-)
Between 2(+) and 5(-)
Between 3(+) and 5(-)

No

(Fixed to either 5 or 0 V DC)

Does the voltage between each terminal become 5 and 0 V DC repeatedly?

No

Yes

Does the outdoor fan motor rotate smoothly?

No

Yes

Replace the outdoor fan motor.

Replace the inverter P.C. board.

J Check of power supply

Disconnect the connector between the compressor and the power module (IC700).
Turn ON power supply and press the emergency operation switch.

Does the left lamp of the OPERATION INDICATOR lamp on the indoor unit light up?

No

Is there voltage 208/230 V AC between the indoor terminal block S1 and S2?

No

Replace the indoor electronic control P.C. board.

Rectify indoor/outdoor connecting wire.

Yes

Is there bus-bar voltage 260 - 370 V DC between 294 - 370 V DC between IC700 (P) and (N) on the inverter P.C. board? (Refer to 10-6.1.)

Yes

Does LED on the inverter P.C. board light up or blink? (Refer to 10-6.1.)

No

Replace the inverter P.C. board.

No

Check the electric parts in main circuit.

If lights up, OK.
If blinks, refer to 10-3.

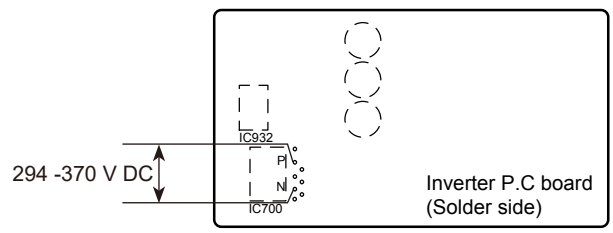

MUZ-GS30/36
MUY-GS30/36

Ⓚ Check of LEV (Expansion valve)

Turn ON the power supply.

<Preparation of the remote controller>

- ① While pressing both Operation select button and TEMP \oplus button on the remote controller at the same time, press RESET button.
- ② First, release RESET button. Hold down the other 2 buttons for another 3 seconds. Make sure that the indicators on the LCD screen shown in the right figure are all displayed. Then release the buttons.

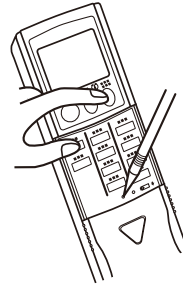

MSZ type

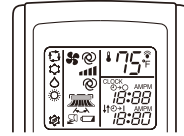

MSY type

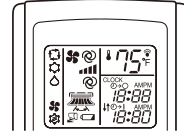

Press OFF/ON (stop/operate) button of the remote controller (the set temperature is displayed) with the remote controller headed towards the indoor unit. *1

Expansion valve operates in full-opening direction.

Do you hear the expansion valve "click, click....." ?
Do you feel the expansion valve vibrate when touching it ?

Yes → OK

No

Is LEV coil properly fixed to the expansion valve?

No

Properly fix the LEV coil to the expansion valve.

Yes

Does the resistance of LEV coil have the characteristics? (Refer to 10-4.)

Yes

Measure each voltage between connector pins of CN724 on the inverter P.C. board.

1. Pin③(-) — Pin①(+)
2. Pin④(-) — Pin①(+)
3. Pin⑤(-) — Pin①(+)
4. Pin⑥(-) — Pin①(+)

Is there about 3 - 5 V AC between each?
NOTE: Measure the voltage by an analog tester.

No

Replace the inverter P.C. board.

Replace the LEV coil.

Yes

Replace the expansion valve.

*1. Regardless of normal or abnormal condition, a short beep is emitted once the signal is received.

NOTE: After check of LEV, take the following steps.

1. Turn OFF the power supply and turn it ON again.
2. Press RESET button on the remote controller.

L Check of inverter P.C. board

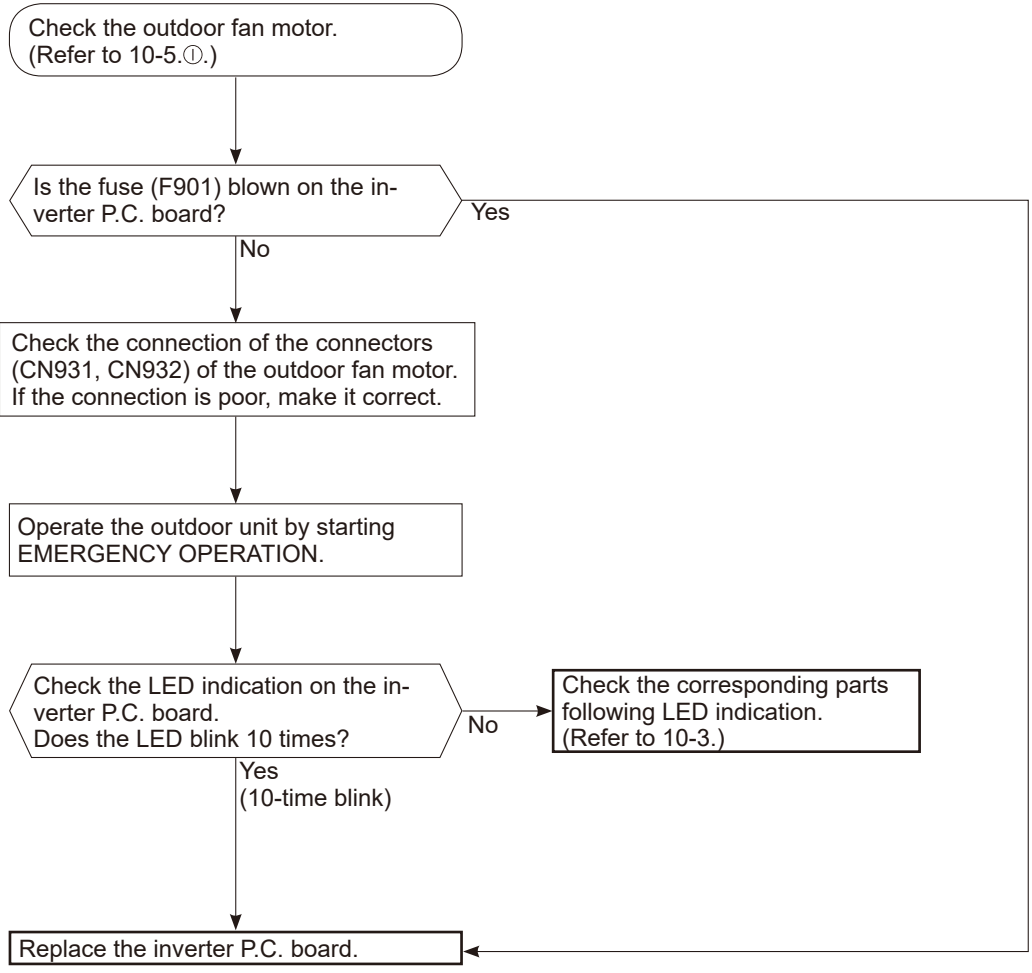

M How to check miswiring and serial signal error

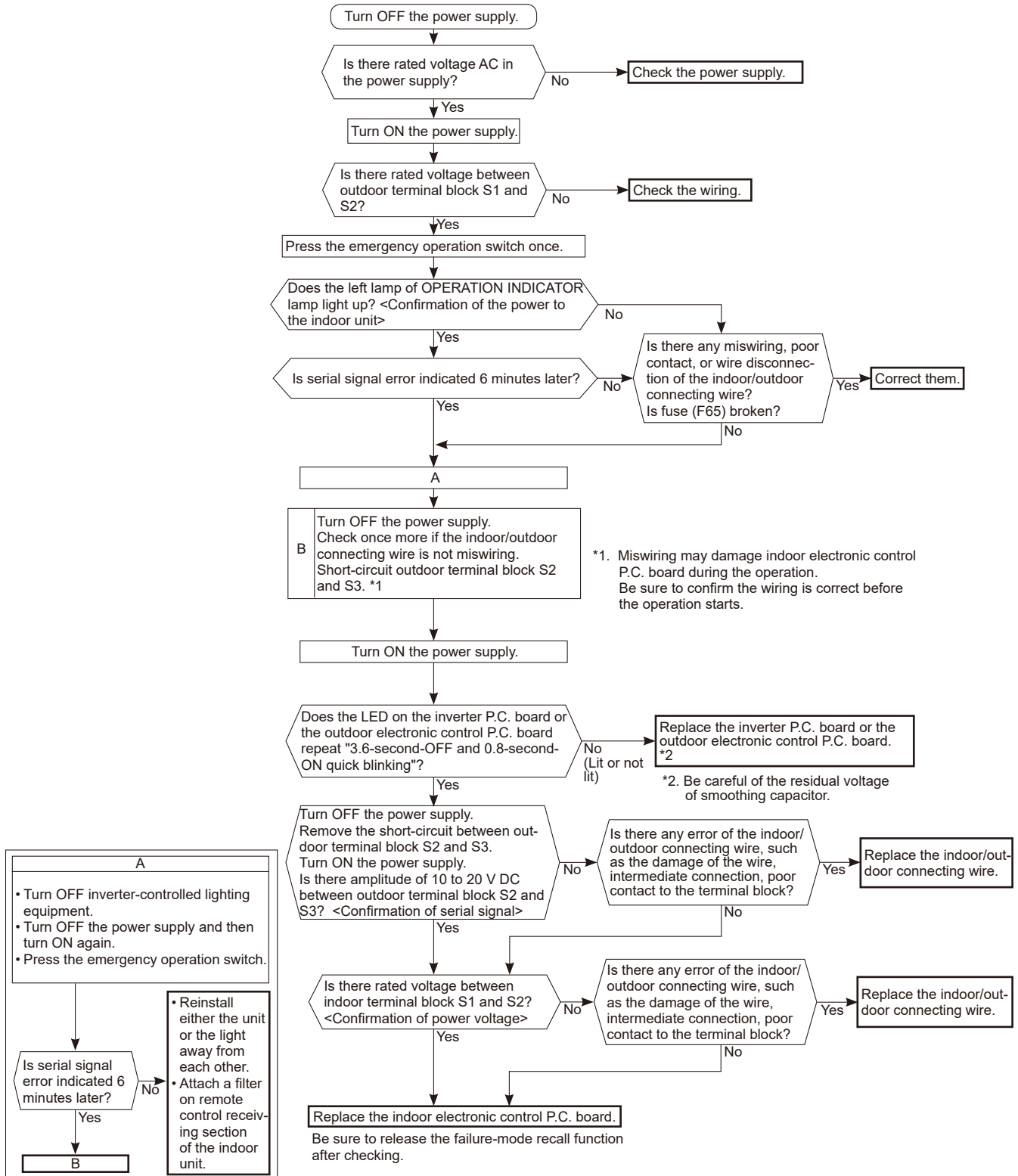

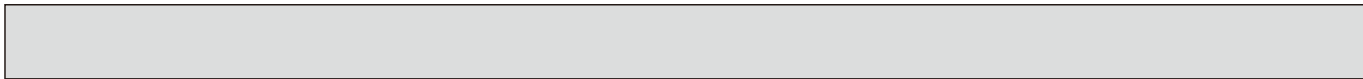

N Check of defrost heater

MUZ-GS30NA MUZ-GS30NAH MUZ-GS36NA MUZ-GS36NAH MUY-GS30NA MUY-GS36NA

Check the following points before checking electric continuity.

1. Does the resistance of ambient temperature thermistor have the characteristics? Refer to 10-6.1.
2. Is the resistance of defrost heater normal? Refer to 10-4.
3. Does the heater protector remain conducted (not open)?
4. Are both ambient temperature thermistor and circuit of defrost heater securely connected to connectors?

In HEAT mode, for more than 5 minutes, let the ambient temperature thermistor continue to read 32°F (0°C) or below, and let the defrost thermistor continue to read 30°F (-1°C) or below.

NOTE: In case both thermistors are more than the above temperature, cool them with cold water etc...

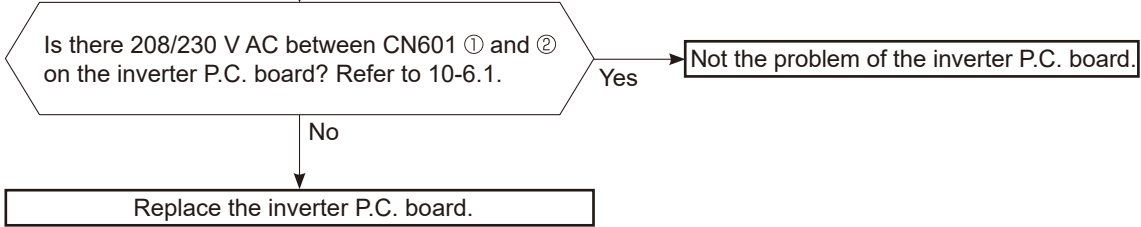

O Check of outdoor refrigerant circuit

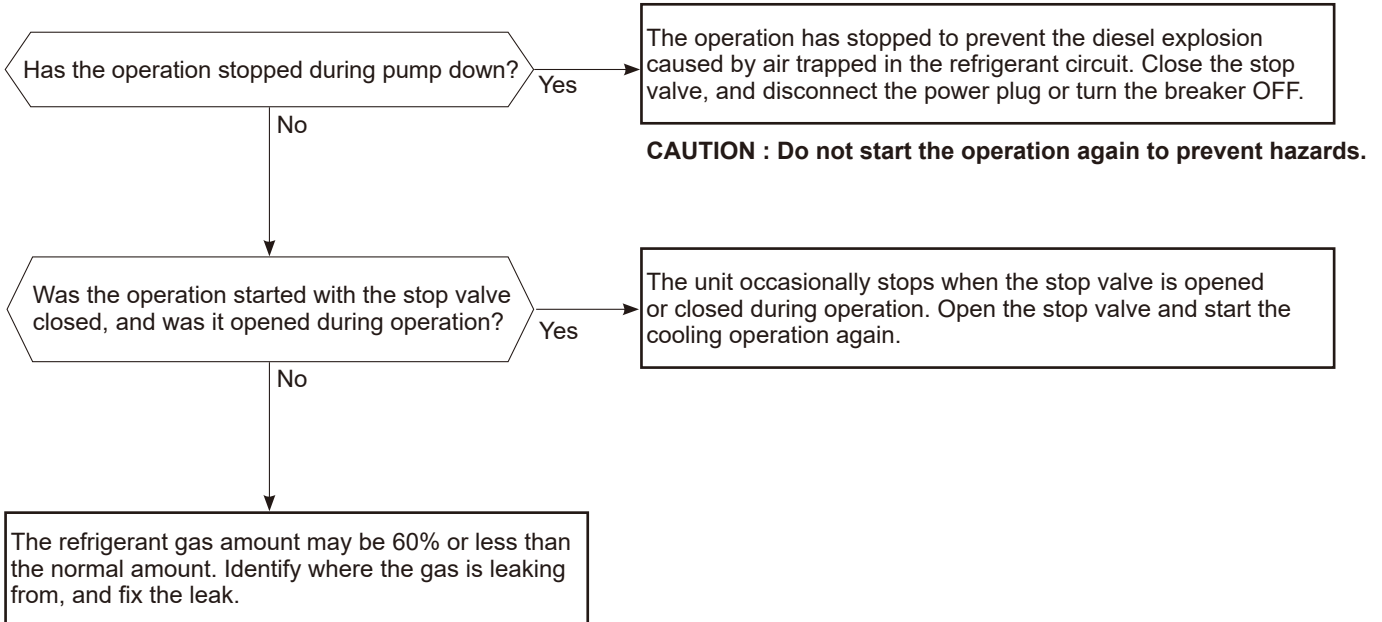

P Electromagnetic noise enters into TV sets or radios

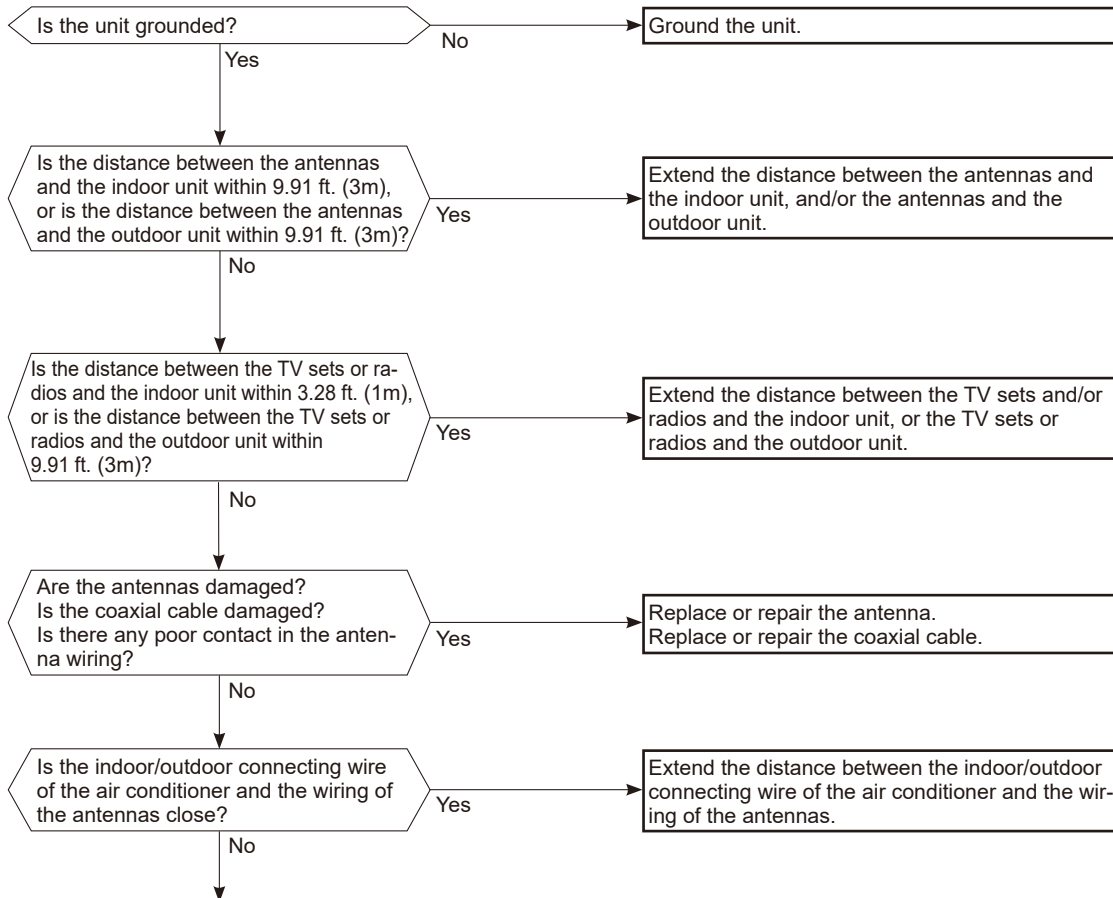

Even if all of the above conditions are fulfilled, the electromagnetic noise may enter, depending on the electric field strength or the installation condition (combination of specific conditions such as antennas or wiring).

Check the following before asking for service.

1. Devices affected by the electromagnetic noise
TV sets, radios (FM/AM broadcast, shortwave)
2. Channel, frequency, broadcast station affected by the electromagnetic noise
3. Channel, frequency, broadcast station unaffected by the electromagnetic noise
4. Layout of:
indoor/outdoor unit of the air conditioner, indoor/outdoor wiring, ground wire, antennas, wiring from antennas, receiver
5. Electric field intensity of the broadcast station affected by the electromagnetic noise
6. Presence or absence of amplifier such as booster
7. Operation condition of air conditioner when the electromagnetic noise enters in
 - 1) Turn OFF the power supply once, and then turn ON the power supply. In this situation, check for the electromagnetic noise.
 - 2) Within 3 minutes after turning ON the power supply, press OFF/ON (stop/operate) button on the remote controller for power ON, and check for the electromagnetic noise.
 - 3) After a short time (3 minutes later after turning ON), the outdoor unit starts running. During operation, check for the electromagnetic noise.
 - 4) Press OFF/ON (stop/operate) button on the remote controller for power OFF, when the outdoor unit stops but the indoor/outdoor communication still runs on. In this situation, check for the electromagnetic noise.

10-6. TEST POINT DIAGRAM AND VOLTAGE

1. Inverter P.C. board

MUZ-GS30NA MUZ-GS30NAH MUZ-GS36NA MUZ-GS36NAH MUY-GS30NA MUY-GS36NA

Back side of unit

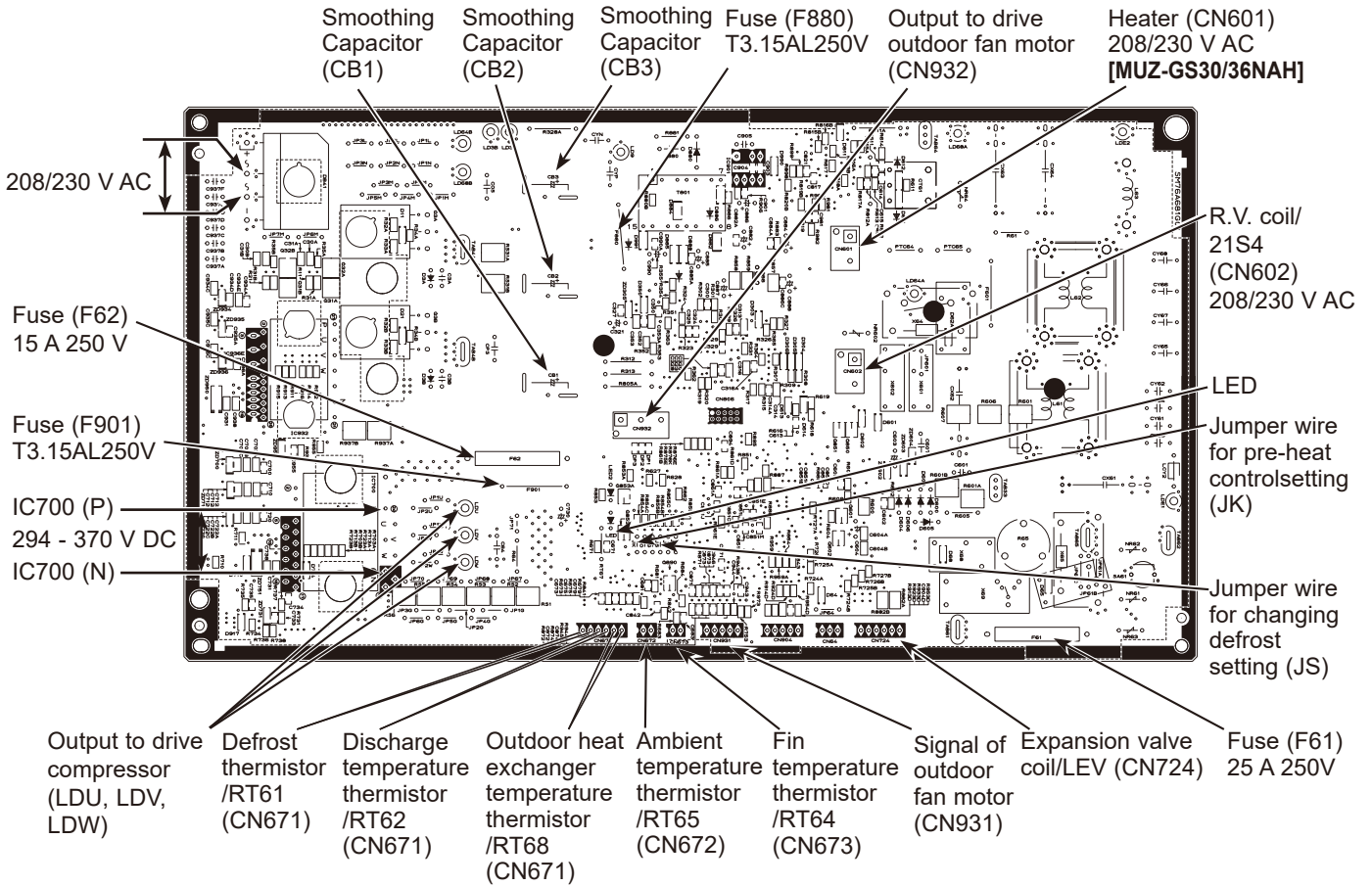

Front side of unit

Defrost thermistor (RT61)
Ambient temperature thermistor (RT65)
Outdoor heat exchanger temperature thermistor (RT68)

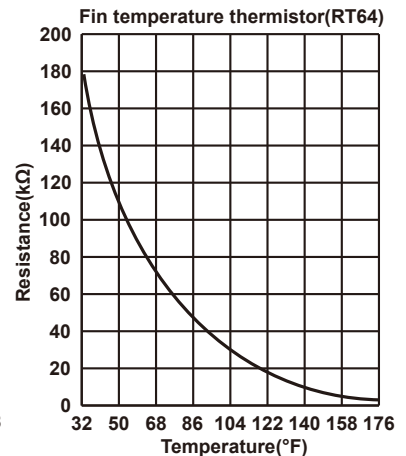
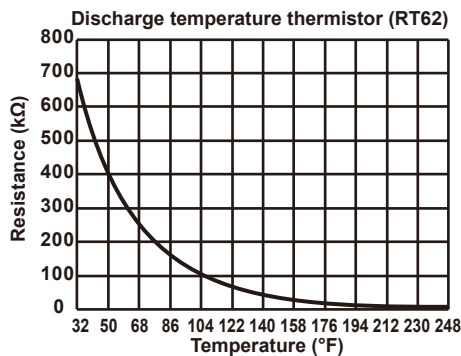
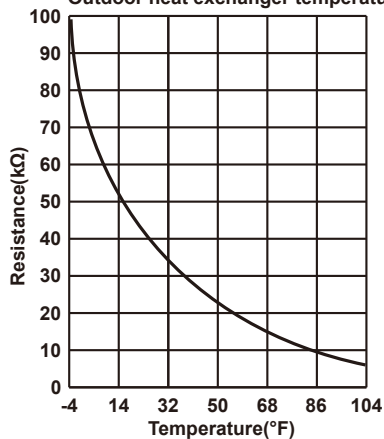

<Detaching method of the terminal with locking mechanism>

The terminal which has the locking mechanism can be detached as shown below.

There are 2 types of the terminal with locking mechanism.

The terminal without locking mechanism can be detached by pulling it out.

Check the shape of the terminal before detaching.

(1) Slide the sleeve and check if there is a locking lever or not.

(2) The terminal with the connector shown below has the locking mechanism.

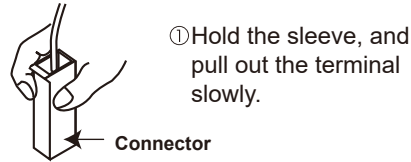
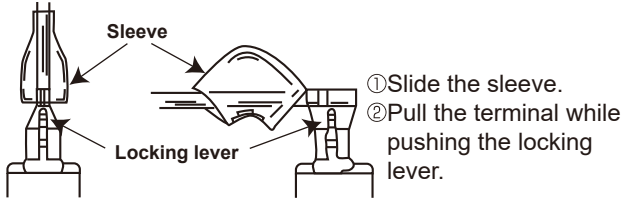

11-1. MUZ-GS30NA MUZ-GS30NAH MUZ-GS36NA MUZ-GS36NAH MUY-GS30NA MUY-GS30NAH

NOTE: Turn OFF the power supply before disassembly.

—————>: Indicates the visible parts in the photos/figures.
- - - - ->: Indicates the invisible parts in the photos/figures.

OPERATING PROCEDURE	PHOTOS/FIGURES
<p>1. Removing the cabinet</p> <ol style="list-style-type: none"> (1) Remove the screws of the service panel. (2) Remove the screws of the top panel. (3) Remove the screw of the valve cover. (4) Remove the service panel. (5) Remove the top panel. (6) Remove the valve cover. (7) Disconnect the power supply and indoor/outdoor connecting wire. (8) Remove the screws of the cabinet. (9) Remove the cabinet. (10) Remove the screws of the back panel. (11) Remove the back panel. <p>Photo 2 Screws of the top panel</p>	<p>Photo 1 Screws of the top panel</p>

OPERATING PROCEDURE

2. Removing the inverter assembly and inverter P.C. board

- (1) Remove the cabinet and panels. (Refer to section 1.)
- (2) Disconnect the lead wire to the reactor and the following connectors:
<Inverter P.C. board>
CN602 (R.V. coil)
CN931, CN932 (Fan motor)
CN671 (Defrost thermistor, discharge temperature thermistor and outdoor heat exchanger temperature thermistor)
CN672 (Ambient temperature thermistor)
CN724 (LEV)
CN601 (Defrost heater and heater protector)
(MUZ-GS30/36NAH)
- (3) Remove the compressor connector (CN61).
- (4) Remove the screws fixing the heat sink support and the separator.
- (5) Remove the screws fixing the P.C. board support and the motor support.
- (6) Remove the fixing screws of the terminal block support and the back panel.
- (7) Remove the inverter assembly.
- (8) Remove the screws of the ground wires.
- (9) Remove the screw of the heat sink support, and the heat sink support from the P.C. board support.
- (10) Remove the screws of the terminal block support, and the screws of the ground wires. (Photo 7)
- (11) Remove the terminal block support.

Photo 6 (Inverter assembly)

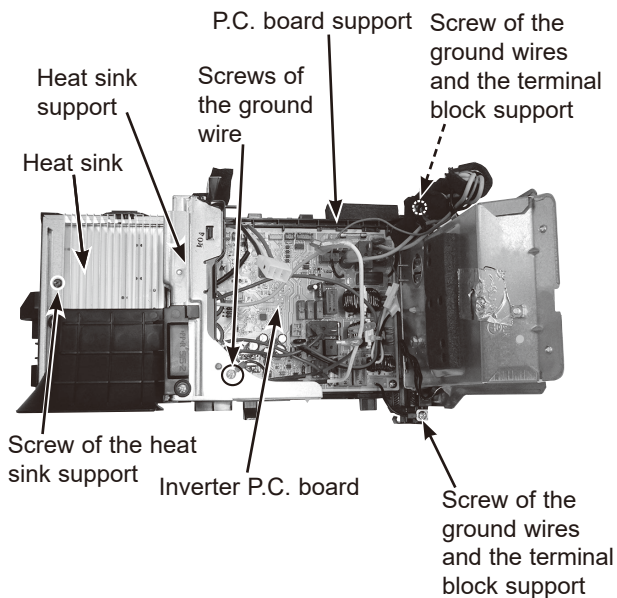

PHOTOS/FIGURES

Photo 3

Screws of the conduit cover

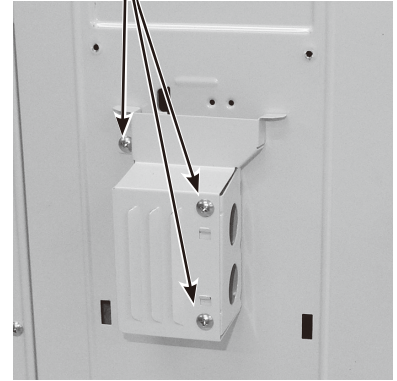

Photo 4

Screw of the conduit plate

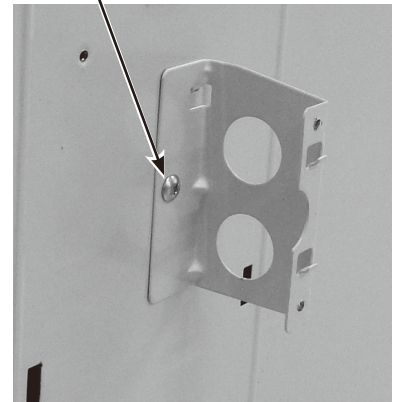
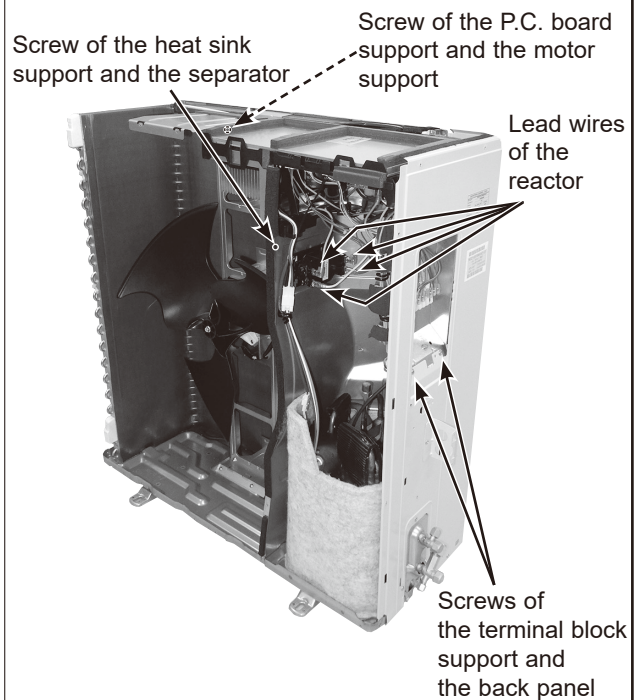

Photo 5



OPERATING PROCEDURE

* Connection procedure when attaching the inverter P.C. board (Photo 8, 9)

1. Attach the heat sink support to the P.C. board support.
2. Hook the lead wires of the compressor, the reactor and the P.C. board to each hooks on the heat sink support as shown Photo 8.
3. Connect the lead wires of the expansion valve coil to the connector on the inverter P.C. board. Pull the lead wires of the expansion valve coil toward you and put them on the left hook on the P.C. board support as shown in Photo 9.

PHOTOS/FIGURES

Photo 7

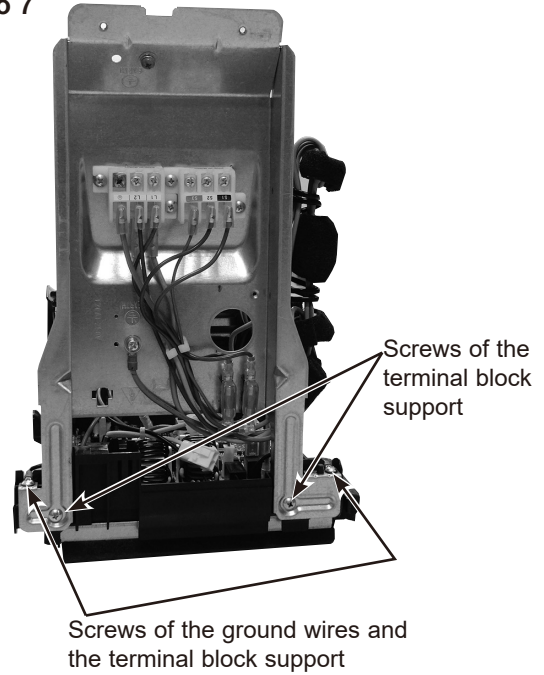

Photo 8

Hook of the lead wires of the P.C. board

Hook of the lead wires of the reactor

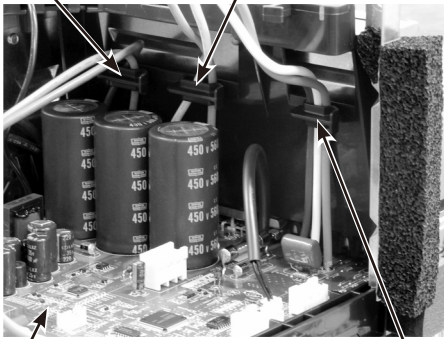

Photo 9

Lead wires of the expansion valve coil





OPERATING PROCEDURE

3. Removing the discharge temperature thermistor, defrost thermistor, outdoor heat exchanger temperature thermistor and ambient temperature thermistor

- (1) Remove the cabinet and panels. (Refer to section 1.)
- (2) Disconnect the lead wire to the reactor and the following connectors:
<Inverter P.C. board>
CN671 (Defrost thermistor, discharge temperature thermistor and outdoor heat exchanger temperature thermistor)
CN672 (Ambient temperature thermistor)
- (3) Pull out the discharge temperature thermistor from its holder. (Photo 12)
- (4) Pull out the defrost thermistor from its holder.
- (5) Pull out the outdoor heat exchanger temperature thermistor from its holder. (Photo 10)
- (6) Pull out the ambient temperature thermistor from its holder.

PHOTOS/FIGURES

Photo 10

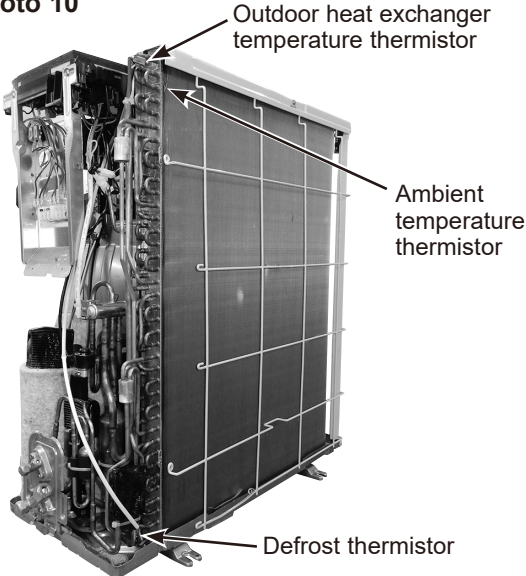

4. Removing outdoor fan motor

- (1) Remove the top panel, cabinet and service panel. (Refer to section 1.)
- (2) Disconnect the following connectors:
<Inverter P.C. board>
CN931, CN932 (Fan motor)
- (3) Remove the propeller fan nut.
- (4) Remove the propeller fan.
- (5) Remove the screws fixing the fan motor.
- (6) Remove the fan motor.

Photo 11

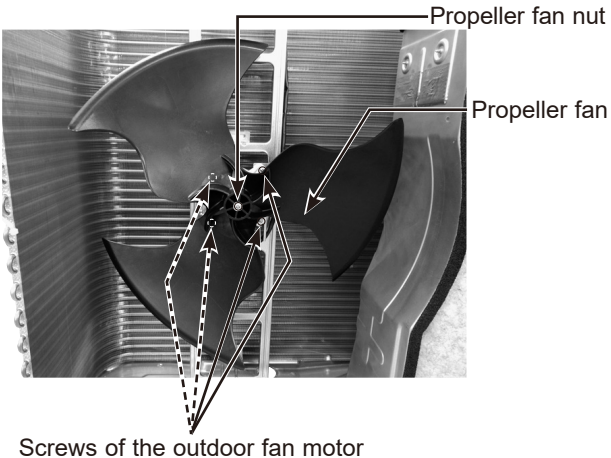

OPERATING PROCEDURE

5. Removing the compressor and 4-way valve

- (1) Remove the top panel, cabinet and service panel. (Refer to section 1.)
- (2) Remove the back panel. (Refer to section 1.)
- (3) Remove the inverter assembly. (Refer to section 2.)
- (4) Recover gas from the refrigerant circuit.

NOTE: Recover gas from the pipes until the pressure gauge shows 0 PSIG.

- (5) Detach the brazed part of the suction and the discharge pipe connected with compressor.
- (6) Remove the compressor nuts.
- (7) Remove the compressor.
- (8) Detach the brazed parts of 4-way valve and pipe. (Photo 13)

PHOTOS/FIGURES

Photo 12

Brazed part of the discharge pipe

Brazed part of the suction pipe



Discharge temperature thermistor

Photo 13

Brazed parts of 4-way valve



MITSUBISHI ELECTRIC CORPORATION

HEAD OFFICE: TOKYO BUILDING, 2-7-3, MARUNOUCHI, CHIYODA-KU, TOKYO 100-8310, JAPAN

© Copyright 2021 MITSUBISHI ELECTRIC CORPORATION

Issued: Jun. 2021. No. OBH875 REVISED EDITION-A

Published: Jan. 2021. No. OBH875

Made in Japan

Specifications are subject to change without notice.