



Job Name:

System Reference:

Date:

Indoor Unit: MFZ-KJ12NA	Outdoor Unit: MUFZ-KJ12NAHZ	Wireless Remote Controller
		

### GENERAL FEATURES

- Floor-mounted indoor unit mounts on the floor or up to 5" above the floor
- Floor front panel access to the filter for ease of cleaning
- Perfect for difficult areas that may be smaller or don't have usable space on the walls
- Multiple fan speed options: Quiet, Low, Medium, High, Super-high, Auto
- Quiet operation
- Multi-flow vane for faster heating
- Multiple control options available:
  - Hand-held Remote Controller (provided with unit)
  - kumo cloud® smart device app for remote access
  - Third-party interface options
  - Wired or wireless controllers
- Unit can be recessed mounted into wall

## SPECIFICATIONS: MFZ-KJ12NA & MUFZ-KJ12NAHZ

Cooling <sup>1</sup>	Maximum Capacity	Btu/h	15,000
	Rated Capacity	Btu/h	12,000
	Minimum Capacity	Btu/h	2,300
	Maximum Power Input	W	1,380
	Rated Power Input	W	890
	Moisture Removal	Pints/h	2.7
	Sensible Heat Factor		0.70
	Power Factor	%	89/89
Heating at 47°F <sup>2</sup>	Maximum Capacity	Btu/h	22,800
	Rated Capacity	Btu/h	13,000
	Minimum Capacity	Btu/h	2,900
	Maximum Power Input	W	2,390
	Rated Power Input	W	900
	Power Factor	%	97/97
Heating at 17°F <sup>3</sup>	Maximum Capacity	Btu/h	14,800
	Rated Capacity	Btu/h	8,800
	Maximum Power Input	W	1,890
	Rated Power Input	W	930
Heating at 5°F <sup>4</sup>	Maximum Capacity	Btu/h	13,000
	Maximum Power Input	W	1810
Heating at -4°F <sup>5</sup>	Maximum Capacity	Btu/h	10,790
Heating at -13°F <sup>6</sup>	Maximum Capacity	Btu/h	8,450
Efficiency	SEER		25.5
	EER <sup>1</sup>		13.6
	HSPF (IV)		12.0
	COP at 47°F <sup>2</sup>		4.23
	COP at 17°F in Maximum Capacity <sup>3</sup>		2.30
	COP at 5°F in Maximum Capacity <sup>4</sup>		2.11
	ENERGY STAR® (ENERGY STAR products are third-party certified by an EPA-recognized Certification Body.)		YES
Electrical	Voltage, Phase, Frequency		208/230V, 1 phase, 60Hz
	Guaranteed Voltage Range	V AC	187-253
	Voltage: Indoor - Outdoor, S1-S2	V AC	208/230
	Voltage: Indoor - Outdoor, S2-S3	V DC	24
	Voltage: Indoor - Remote Controller		Wireless Type
	Recommended Fuse/Breaker Size	A	15
	Recommended Wire Size (Indoor - Outdoor)	AWG	14
Indoor Unit	MCA	A	1
	MOCP	A	15
	Blower Motor Full Load Amperage	A	0.62
	Blower Motor Output	W	30

## SPECIFICATIONS: MFZ-KJ12NA & MUFZ-KJ12NAHZ

	Airflow Rate at Cooling, Dry	CFM	417-360-272-198-138	
	Airflow Rate at Cooling, Wet	CFM	354-306-231-168-117	
	Airflow Rate at Heating, Dry	CFM	417-328-254-191-138	
	Sound Pressure Level (Cooling)	dB(A)	46-41-34-27-21	
	Sound Pressure Level (Heating)	dB(A)	46-40-34-27-21	
	Drain Pipe Size	In. (mm)	5/8 (15.88)	
	Heat Exchanger Type		Plate fin coil	
	External Finish Color		White	
	Unit Dimensions	W: In. (mm)	29-17/32 (750)	
		D: In. (mm)	8-15/33 (215)	
		H: In. (mm)	23-5/8 (600)	
	Package Dimensions	W: In. (mm)	32-2/16 (816)	
		D: In. (mm)	10-13/16 (275)	
		H: In. (mm)	27-12/16 (693)	
	Unit Weight	Lbs. (kg)	33 (15)	
	Package Weight	Lbs. (kg)	41 (18.5)	
Indoor Unit Operating Temperature Range	Cooling Intake Air Temp (Maximum / Minimum)*	°F	90 DB / 73 WB // 67 DB / 57 WB	
	Heating Intake Air Temp (Maximum / Minimum)	°F	80 DB // 70 DB	
Outdoor Unit	MCA	A	11	
	MOCP	A	15	
	Fan Motor Full Load Amperage	A	0.5	
	Fan Motor Output	W	50	
	Airflow Rate	CFM	1,074 / 1,202	
	Refrigerant Control		LEV	
	Defrost Method		Reverse cycle	
	Heat Exchanger Type		Plate fin coil	
	Sound Pressure Level, Cooling <sup>1</sup>	dB(A)	50	
	Sound Pressure Level, Heating <sup>2</sup>	dB(A)	48	
	Compressor Type		DC INVERTER-driven Twin Rotary	
	Compressor Model		SNB140FQUMT	
	Compressor Rated Load Amps	A	8.2	
	Compressor Locked Rotor Amps	A	10.3	
	Compressor Oil Type // Charge	oz.	FV50S // 11.8	
	External Finish Color		Munsell 3Y 7.8/1/1	
	Base Pan Heater		Built-in	
	Unit Dimensions	W: In. (mm)		31-1/4 (800)
		D: In. (mm)		11-1/6 (285)
		H: In. (mm)		21-5/8 (550)
Package Dimensions	W: In. (mm)		37 (940)	
	D: In. (mm)		14-15/16 (380)	
	H: In. (mm)		24-13/16 (630)	

## SPECIFICATIONS: MFZ-KJ12NA & MUFZ-KJ12NAHZ

	Unit Weight	Lbs. (kg)	83 (38)
	Package Weight	Lbs. (kg)	89 (41)
Outdoor Unit Operating Temperature Range	Cooling Air Temp (Maximum / Minimum)*	°F	14 to 115
	Cooling Thermal Lock-out / Re-start Temperatures**	°F	11 / 14
	Heating Air Temp (Maximum / Minimum)	°F	-13 to 75
	Heating Thermal Lock-out / Re-start Temperatures**	°F	-18 / -14
Refrigerant	Type		R410A
	Charge	Lbs, oz	2, 10
Piping	Gas Pipe Size O.D. (Flared)	In. (mm)	3/8 (9.52)
	Liquid Pipe Size O.D. (Flared)	In. (mm)	1/4 (6.35)
	Maximum Piping Length	Ft. (m)	65 (20)
	Maximum Height Difference	Ft. (m)	40 (12)
	Maximum Number of Bends		10

### Notes

AHRI Rated Conditions (Rated data is determined at a fixed compressor speed)	<sup>1</sup> Cooling (Indoor // Outdoor)	°F	80 DB, 67 WB // 95 DB, 75 WB
	<sup>2</sup> Heating at 47°F (Indoor // Outdoor)	°F	70 DB, 60 WB // 47 DB, 43 WB
	<sup>3</sup> Heating at 17°F (Indoor // Outdoor)	°F	70 DB, 60 WB // 17 DB, 15 WB
Conditions	<sup>4</sup> Heating at 5°F (Indoor // Outdoor)	°F	70 DB, 60 WB // 5 DB, 4 WB
	<sup>5</sup> Heating at -4°F (Indoor // Outdoor)	°F	70 DB, 60 WB // -4 DB, -5 WB
	<sup>6</sup> Heating at -13°F (Indoor // Outdoor)	°F	70 DB, 60 WB // -13 DB, -14 WB

\*Applications should be restricted to comfort cooling only; equipment cooling applications are not recommended for low ambient temperature conditions.

\*\*System cuts out in heating mode to avoid thermistor error and automatically restarts at these temperatures.

## ACCESSORIES: MFZ-KJ12NA

Anti-allergy Enzyme Filter	□ MAC-408FT-E
Backlit, Wall-mounted, Wireless Controller	□ MHK1
Portable Central Controller	□ MCCH1
Wired MA Controller <sup>1</sup>	□ PAR-33MAA
Simple MA Controller <sup>1</sup>	□ PAC-YT53CRAU
Touch MA Controller <sup>1</sup>	□ PAR-CT01MAU-SB
Wired Remote Sensor	□ M21-EAA-307
Wireless Temperature and Humidity Sensor	□ PAC-USWHS003-TH-1
Outside Air Sensor for MHK1	□ MOS1
System Control Interface <sup>2</sup>	□ MAC-333IF-E
Wireless Interface	□ PAC-USWHS002-WF-1
Thermostat Interface	□ PAC-US444CN-1
kumo station <sup>®</sup>	□ PAC-WHS01HC-E
USNAP Interface	□ PAC-WHS01UP-E
IT Extender	□ PAC-WHS01IE-E
BACnet <sup>®</sup> and MODBUS <sup>®</sup> Interface	□ PAC-UKPRC001-CN-1
External Fan / Heater Control Relay Adapter	□ CN24RELAY-KIT-CM3
Lockdown Bracket for Hand-held Remote Controllers	□ RCMKP1CB
Blue Diamond Sensor Extension Cable — 15 Ft.	□ C13-103
Blue Diamond Alarm Extension Cable — 6.5 Ft.	□ C13-192
Blue Diamond MultiTank — collection tank for use with multiple pumps	□ C21-014
Blue Diamond Rubber Foot Pads	□ F10-010
Mini Condensate Pump — 230 volt application	□ SI30-230
MegaBlue Advanced Blue Diamond Condensate Pump w/ Reservoir & Sensor	□ X87-835 - 110 to 250V
MaxiBlue Advanced Blue Diamond Mini Condensate Pump w/ Reservoir & Sensor (110V) up to 48,000 Btu/h [recommended]	□ X87-711 - 110V
Advanced Blue Diamond Mini Condensate Pump w/ Reservoir & Sensor (208/230V) [recommended]	□ X87-721 - 208/230V
MicroBlue Blue Diamond Mini Condensate Pump (110/208/230V) up to 18,000 Btu/h	□ X85-003
Fascia Kit for MicroBlue Pump – mounts the MicroBlue and sensor directly beneath the indoor unit	□ T18-016
Drain Pan Level Sensor	□ DPLS2
(30A/600V/UL) [fits 2" X 4" utility box] - Black	□ TAZ-MS303
(30A/600V/UL) [fits 2" X 4" utility box] - White	□ TAZ-MS303W

<sup>1</sup> Requires MAC-333IF-E

<sup>2</sup> Allows indoor units to connect to an MA Controller

## ACCESSORIES: MUFZ-KJ12NAHZ

Air Outlet Guide	□ MAC-881SG
Hail Guard	□ HG-B4
Outdoor Unit 3-1/4 inch Mounting Base (Pair) - Plastic	□ DSD-400P
Condensing Unit Mounting Pad 16" x 36" x 3"	□ ULTRILITE1
Outdoor Unit Stand — 12" High	□ QSMS1201M
Outdoor Unit Stand — 18" High	□ QSMS1801M
Outdoor Unit Stand — 24" High	□ QSMS2401M
Heavy Duty Wall Mounting Bracket— Coated Steel	□ QSWB2000M-1
Heavy Duty Wall Mounting Bracket — 316 Series Stainless Steel	□ QSWBSS
15' x 1/4" x 15' / 3/8" Lineset (Twin-Tube Insulation)	□ MLS143812T-15
30' x 1/4" x 30' / 3/8" Lineset (Twin-Tube Insulation)	□ MLS143812T-30
50' x 1/4" x 50' / 3/8" Lineset (Twin-Tube Insulation)	□ MLS143812T-50
65' x 1/4" x 65' / 3/8" Lineset (Twin-Tube Insulation)	□ MLS143812T-65

# DIMENSIONS: MFZ-KJ12NA

Unit: inch

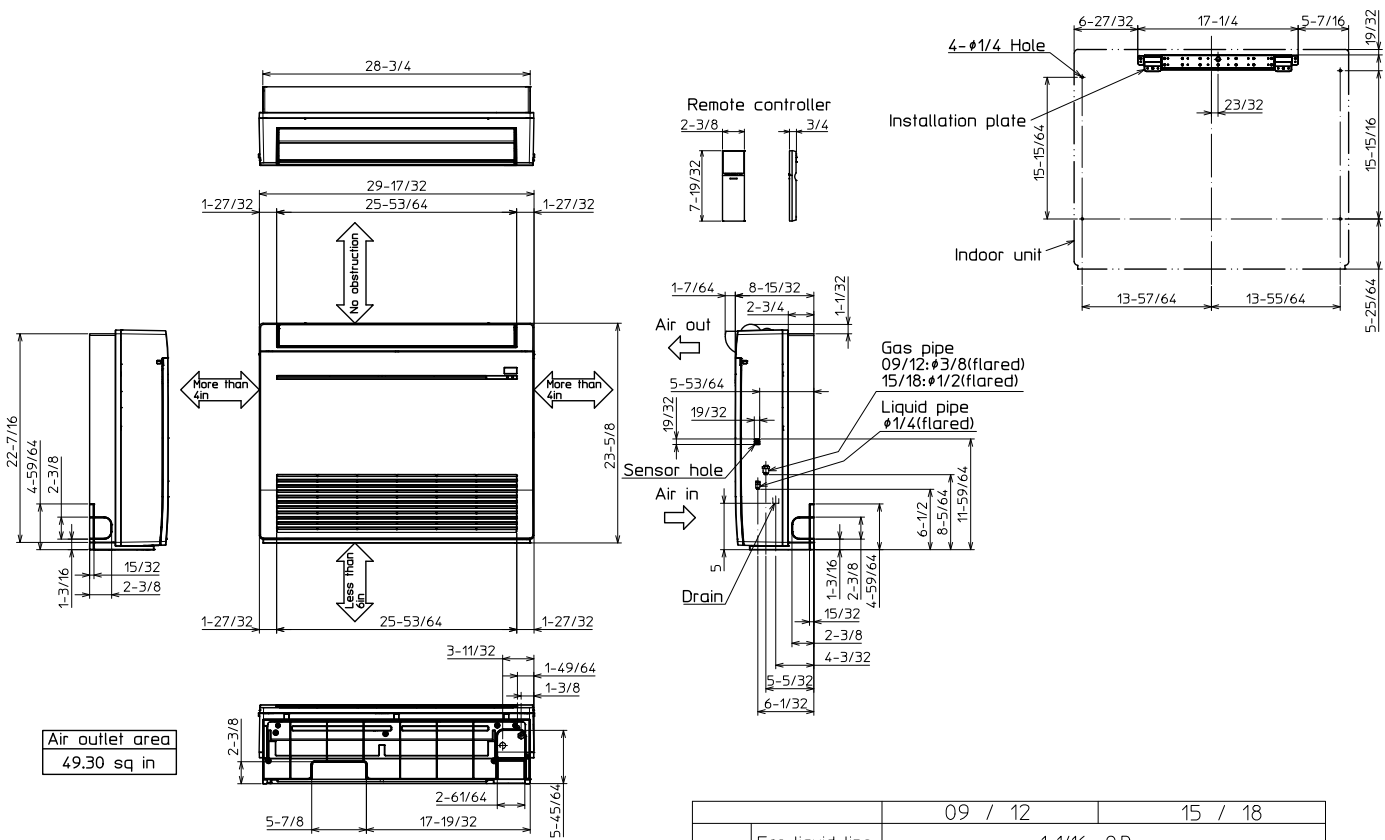

Air outlet area  
49.30 sq in

		09 / 12	15 / 18
Pipe cover	For liquid line	1-1/16 O.D	
	For gas line	1-1/16 O.D	1-7/32 O.D
Piping	Liquid line	Flared connection 1/4	
	Gas line	Flared connection 3/8	Flared connection 1/2
Drain hose	Heat insulater 1-9/64 O.D	Connection point 5/8 O.D	Effective length 13-25/32 (case of right backward piping)

# DIMENSIONS: MUFZ-KJ12NAHZ

Unit: inch

## REQUIRED SPACE

\*1 4 in. or more when  
front and sides of the unit are clear

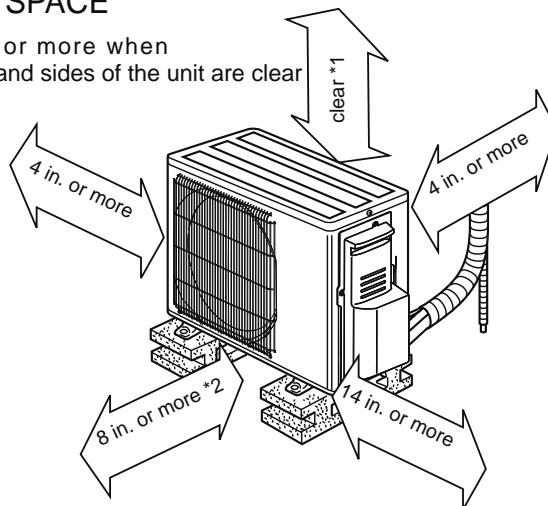

\*2 When any 2 sides of left, right  
and rear of the unit are clear

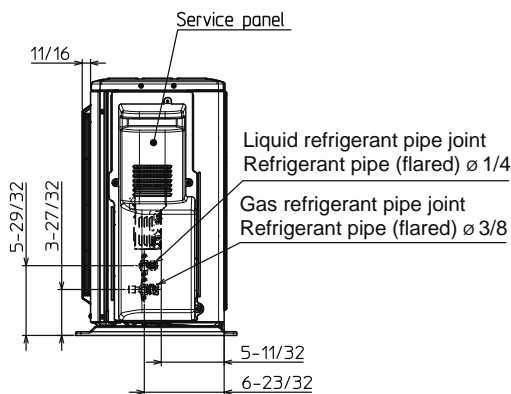
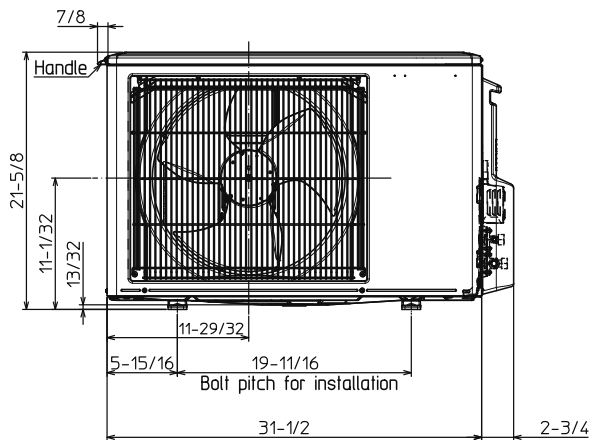
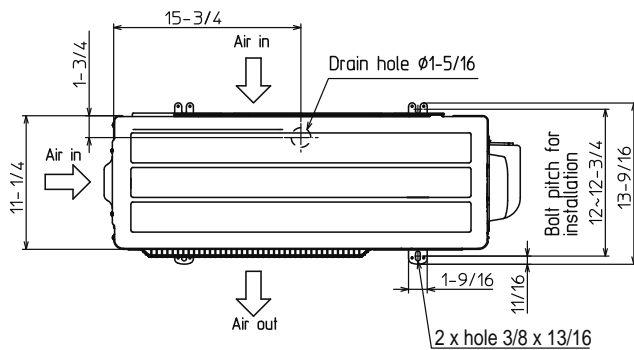

1340 Satellite Boulevard, Suwanee, GA  
002430024  
Toll Free: 800-433-4822 www.mehvac.com

FORM# MFZ-KJ12NA / MUFZ-KJ12NAHZ - 201903



Specifications are subject to change without notice.

© 2019 Mitsubishi Electric Trane HVAC US LLC. All rights reserved.