

Job Name:	Date:
System Reference:	



Indoor Unit: MSY-GL18NA-U1



Wireless Remote Controller



Outdoor Unit: MUY-GL18NA-U1

ACCESSORIES:

Indoor Unit

- Condensate Pump (BlueDiamond X87-711/721; 115/230V)
- Condensate Pump (Sauermann SI30-115/230; 115/230V)
- Anti-Allergy Enzyme Filter (MAC-408FT-E)
- Drain Pan Level Sensor (DPLS2)

Outdoor Unit

- Outdoor Mounting Pad (ULTRILITE1)
- Drain Pan Heater (MAC-640BH-U)
- 3-1/4" Mounting Base [Pair] (DSD-400P)
- Drain Pan Socket (MAC-851DS)
- Air Outlet Guide (MAC-886SG-E)
- Wall Mounting Bracket (QSWB2000M-1)

Controls

- Wireless Controller (MHK1)
- Wired Remote Controller PAR-31MAA (Requires MAC-333IF-E)
- Wireless Interface for kumo cloud™ (PAC-WHS01WF-E)
- Thermostat Interface (PAC-US444CN-1)

SPECIFICATIONS:

Rated Conditions (Capacity / Input)		
Cooling ¹	Btu/h / W	18,000 / 1,340

Capacity Range		Minimum	Maximum
Cooling ¹	Btu/h	5,800	22,000

¹ Cooling | Indoor: 80° F(27° C)DB / 67° F(19° C)WB; Outdoor: 95° F(35° C)DB / 75° F(24° C)WB
^{*} Rating Conditions per AHRI Standard:

Operating Conditions (Indoor Intake Air Temp.) (Max./ Min.)	
Cooling	90° F (32° C) DB / 67° F (19° C) DB

Operating Conditions (Outdoor Intake Air Temp.) (Max./ Min.)	
Cooling ²	115° F (46° C) DB / 14° F (-10° C) DB

² System cuts out at -9° F (-27° C) to avoid thermistor error and automatically restarts at -4° F (-20° C). Applications should be restricted to comfort cooling only; equipment cooling applications are not recommended for low ambient temperature conditions.

AHRI Efficiency Ratings	
SEER	20.5

Energy Star®	Yes
--------------	-----

ENERGY STAR products are third-party certified by an EPA-recognized Certification Body.

Electrical Power Requirements	208 / 230V, 1-Phase, 60 Hz
-------------------------------	----------------------------

Minimum Circuit Ampacity (MCA)		
Indoor / Outdoor	A	1 / 14

Indoor Unit		
Blower Motor (ECM)	F.L.A.	0.67
Blower Motor Output	W	30
SHF / Moisture Removal		0.87 / 2.1 pt./h
Field Drainpipe Size O.D.	In.(mm)	5/8 (15)

Outdoor Unit		
Compressor		DC INVERTER-driven Twin Rotary
Fan Motor (ECM)	F.L.A.	0.93

Airflow Rate (Quiet - Lo - Med - Hi - Super Hi)			
Indoor (Cooling)	DRY	CFM	259-333-416-523-646
	WET		233-300-375-470-581
Outdoor			1,691 / 1,691

Sound Pressure Level (Quiet - Lo - Med - Hi - Super Hi)			
Indoor	Cooling	dB(A)	28-33-38-44-49
Outdoor	Cooling		54

External Dimensions		
Indoor (H x W x D)	In.(mm)	12 x 36-5/16 x 9-13/16 (305 x 923 x 250)
Outdoor (H x W x D)		34-5/8 x 33-1/16 x 13 (880 x 840 x 330)

Net Weight		
Indoor	Lbs.(kg)	28 (13)
Outdoor		121 (55)

External Finish	
Indoor	Munsell 1.0Y 9.2 / 0.2
Outdoor	Munsell No. 3Y 7.8 / 1.1

Refrigerant	R410A; 3 lb. 7 oz.
-------------	--------------------

Refrigerant Piping (Flared)		
Liquid (High Pressure)	In.(mm)	1/4 (6.35)
Gas (Low Pressure)		1/2 (12.7)
Max. Total Refrigerant Pipe Length (Height Diff.)	Ft. (m)	50 (15)
Max. Total Refrigerant Pipe Length (Length.)		100 (30)

DIMENSIONS: MSY-GL18NA-U1 & MUY-GL18NA-U1

MSY-GL18NA-U1

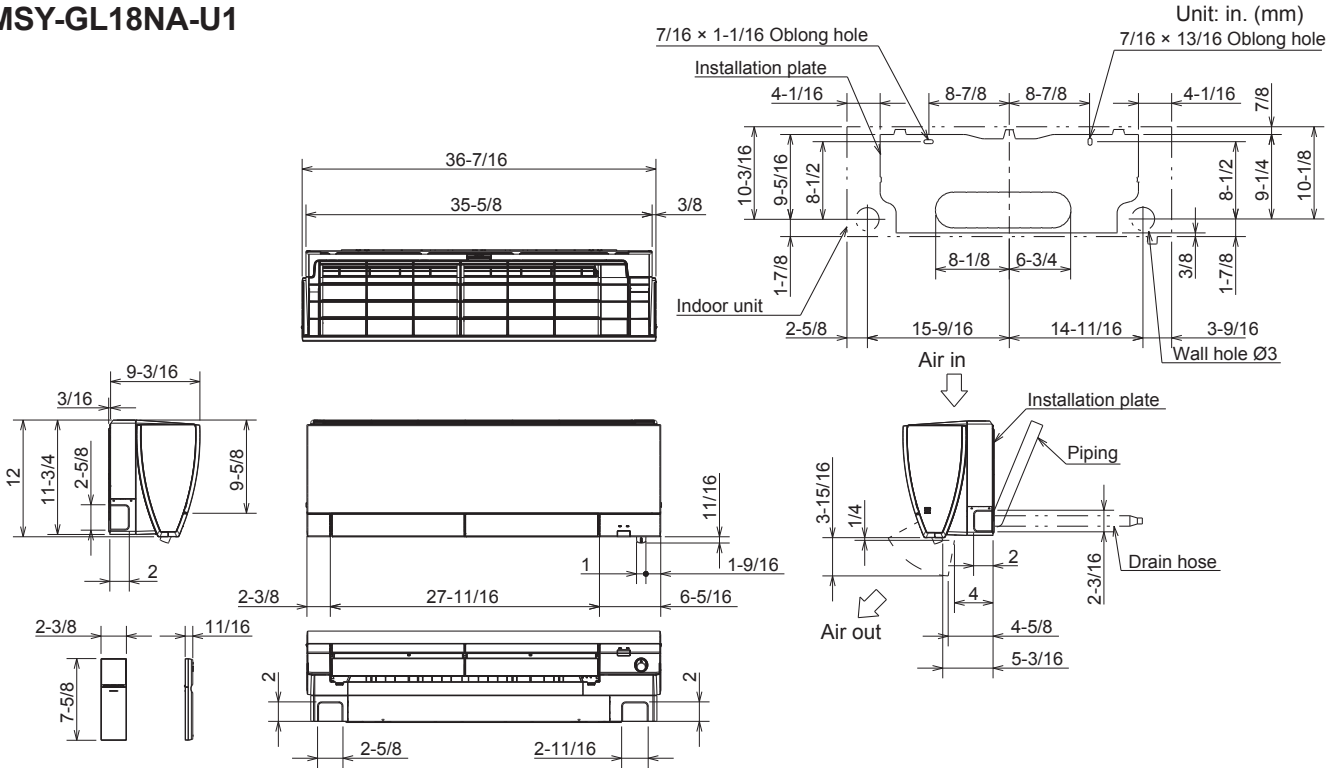

MUY-GL18NA-U1

REQUIRED SPACE

Unit: in. (mm)

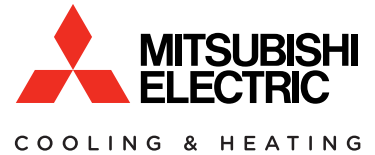
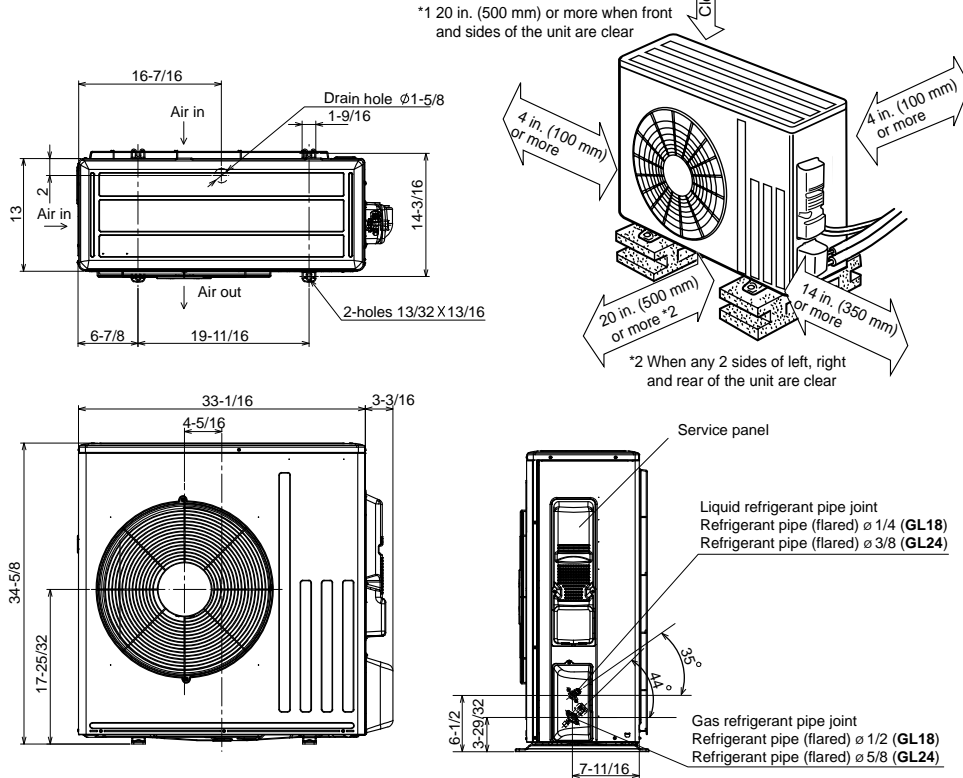

1340 Satellite Boulevard, Suwanee, GA 30024
 Toll Free: 800-433-4822 www.mehvac.com

