

# MISENO

## TWO HANDLE LAVATORY FAUCET

### Product Codes:

- MNO441LCP (Polished Chrome)
- MNO441LFB (Flat Black)
- MNO441LZBN (Brushed Nickel)

- Max flow rate: 1.2 gpm at 60 psi
- Metal handles
- Ceramic disc cartridges
- 3 hole installation with 8" on-center
- With press pop-up assembly
- WaterSense certified
- Certified to ASME A112.18.1/CSA B125.1
- cUPC/IAPMO listed
- Limited lifetime warranty
- ADA compliant
- NSF/ANSI/CAN 61:  $Q \leq 1$

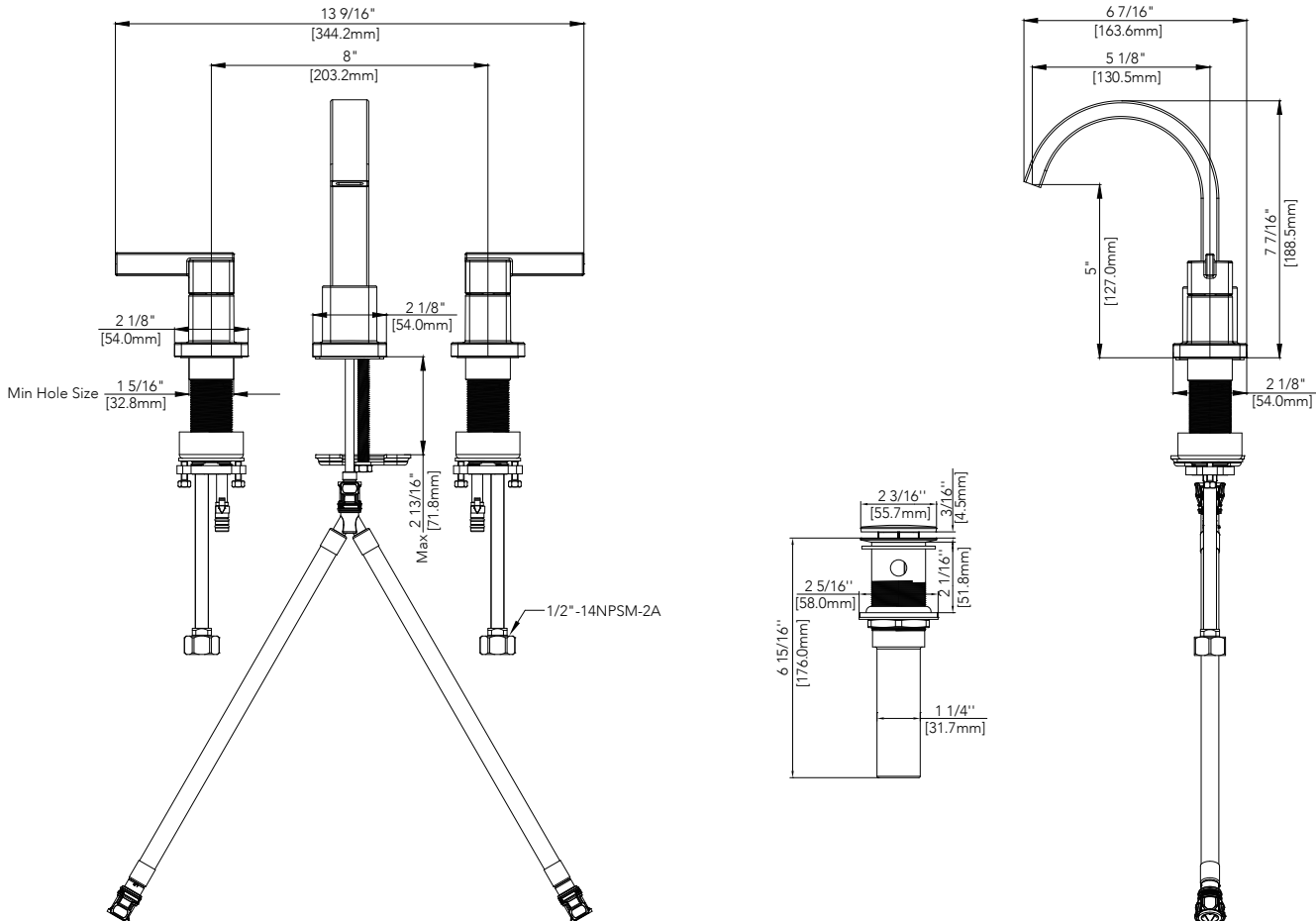

All dimensions are based on original specifications and are subject to change and variation.

