

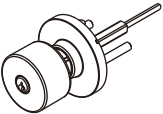







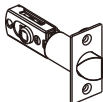

INSTRUCTIONS FOR INSTALLATION OF TUBULAR KNOBSETS

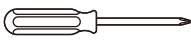
PACKAGE CONTENTS				TOOLS NEEDED (NOT INCLUDED)
Outside Assembly 	Inside Assembly 	Latch 	Strike Plate 	Phillips Screwdriver  
Keys 	Removal Tool 	Latch/Strike Screws Qty. 4 	Mounting Screws Qty. 2 	Tape Measure 

ADJUSTABLE LATCH FOR 2-3/8" (60 mm) AND 2-3/4" (70 mm) BACKSET

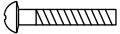

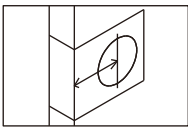
Backset is a distance from the door edge to the centre of the hole on door face. Some locks are supplied with adjustable latch which can fit 2-3/8" (60 mm) or 2-3/4" (70 mm) backset. Just follow the steps shown below to change backset.

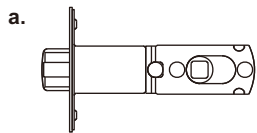

a. This latch is set for 2-3/8" (60 mm) backset.

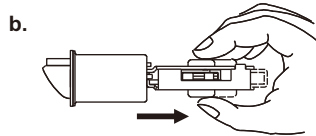

b. Keep spindle cam in correct position as illustrated. Pull spindle cam all the way to right.

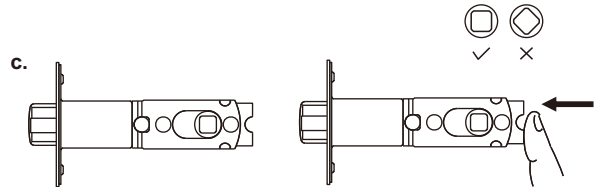

c. Your latch is now set for 2-3/4" (70 mm) backset. To reset 2-3/8" (60 mm) backset, just push spindle cam back to left side. Please make sure that the cams are staying with square shape.

DETERMINE HANDING OF YOUR DOOR

Stand at exterior side and face to your door. Your door is left hand door if hinge were installed at your left hand. Your door is right hand door if hinge were installed at your right hand.

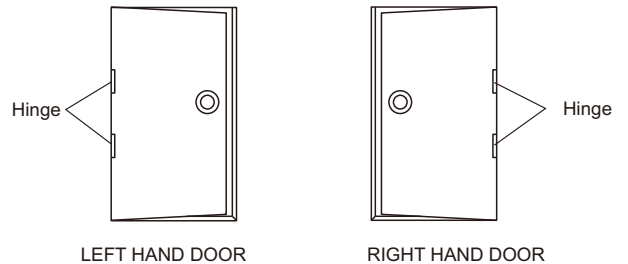

EXTERIOR

PREPARE DOOR AND CHECK DIMENSIONS

Use enclosed template to mark holes on door face. Drill Ø2-1/8" (54 mm) holes from both sides of door. Drill Ø1" (25.4 mm) holes in door edge for latches.

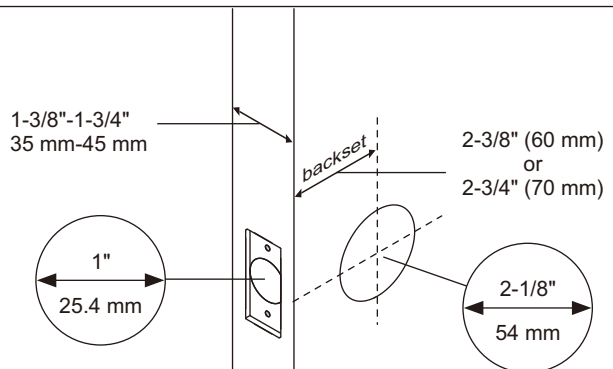

3. INSTALL LATCH

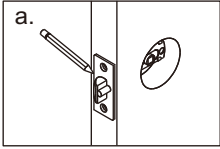

Insert latch in hole and keep it parallel to door face.
Mark outline of face plate and remove latch.

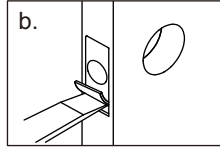

Chisel 1/8" (3 mm) deep or until face plate flush with door edge.

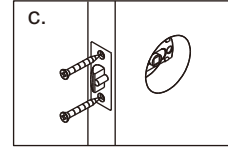

Insert latch and tighten screws.

4. INSTALL OUTSIDE KNOB

Insert spindle through latch.
Press flush against door.

NOTE: Key hole must be in down position.

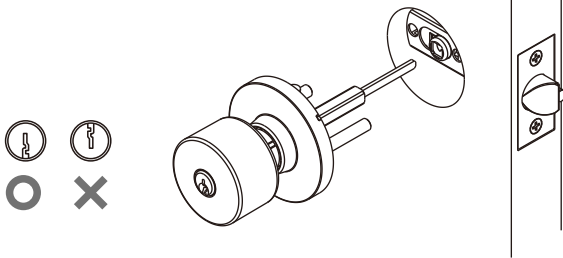

6. INSTALL STRIKE

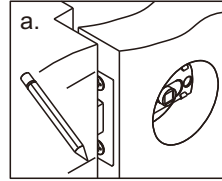

Close door to make horizontal centre line of strike.

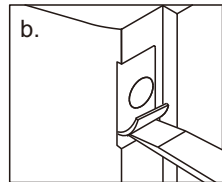

Measure one half of door thickness from door stop and mark vertical centre line of strike.
Drill 1" (25 mm) hole 1/2" (13 mm) deep at intersection of horizontal and vertical line of strike.

Match screw holes on strike with centre lines on jamb.

Mark outline and chisel 1/16" (1.6 mm) deep for strike.

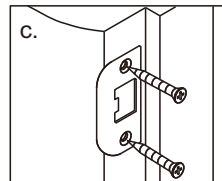

Install strike and tighten screws.

5. INSTALL INSIDE KNOB

Install inside knob and tighten screws until lock is firm.

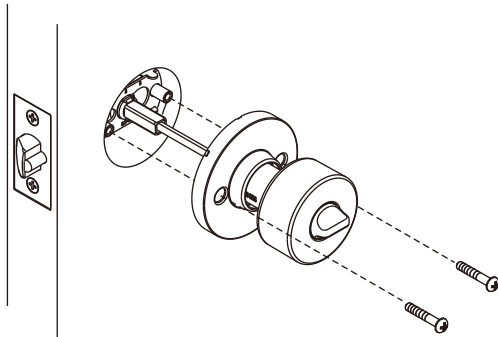

TEMPLATE

Fold on dotted line and fit on door edge

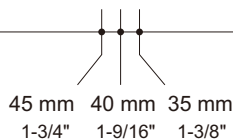

Make 1" (25.4 mm) hole at center of door edge.

FOR BACKSET 2-3/4" (70 mm)

FOR BACKSET 2-3/8" (60 mm)

Ø2-1/8" (54 mm)

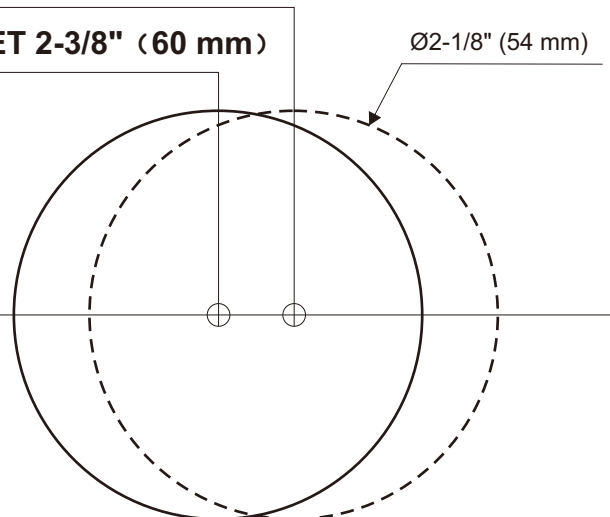

INSTRUCTIONS FOR INSTALLATION OF SINGLE AND DOUBLE CYLINDER DEADLOCKS

JSC-FGS-D101

FOR USE ON DOORS 1-3/8" TO 1-3/4" (35mm-45mm)

1. MARK DOOR A. Fold and apply template to high edge of door bevel and mark center of door edge as indicated on template at the desired height from the floor.		5. INSTALL EXTERIOR MECHANISM A. Press cylinder side flush against door making certain the torque blade is properly positioned in latch crank. B. Tapped holes in mounting plate of exterior cylinder should be lined up with latch holes. Key hole should be in down position.	
2. DRILL HOLES A. Drill thru door face as marked for lockset: It is recommended that holes be drilled from both sides to prevent splitting. Hole size is 2" (50.8mm) for standard installations.		6. INSTALL INTERIOR MECHANISM A. Slide thumb bar and interior rosette onto torque blade.	
3. INSTALL LATCH A. Insert latch in hole keeping it parallel to face of door. Mark outline and remove latch.		INSTRUCTIONS FOR INSTALLING DOUBLE CYLINDER DEADLOCKS Exterior half is fully assembled with exterior torque blade EXTERIOR TORQUE BLADE	
4. INSTALL STRIKE A. Bore 1" hole 1" minimum deep for deadbolt.		NOTE: This assembly is placed through latch first.	
B. Chisel 1/8" deep or until latch face is flush with door edge.		A. Install interior cylinder INTERIOR TORQUE BLADE	
C. Install deadbolt latch in up position into hole as shown on latch insert and tighten screws.		NOTE: The interior torque blade is inserted into the exterior blade.	
B. Mortise 1/16" deep for strike locating from 1" hole in door insert and tighten screws.		B. Press interior assembly flush against door making certain the torque blade is properly positioned in latch hole. Key hole should be in down position.	
C. Insert (2) two screws through countersunk holes engaging holes in exterior cylinder and tighten.		C. Insert (2) two screws through countersunk holes engaging holes in exterior cylinder and tighten.	

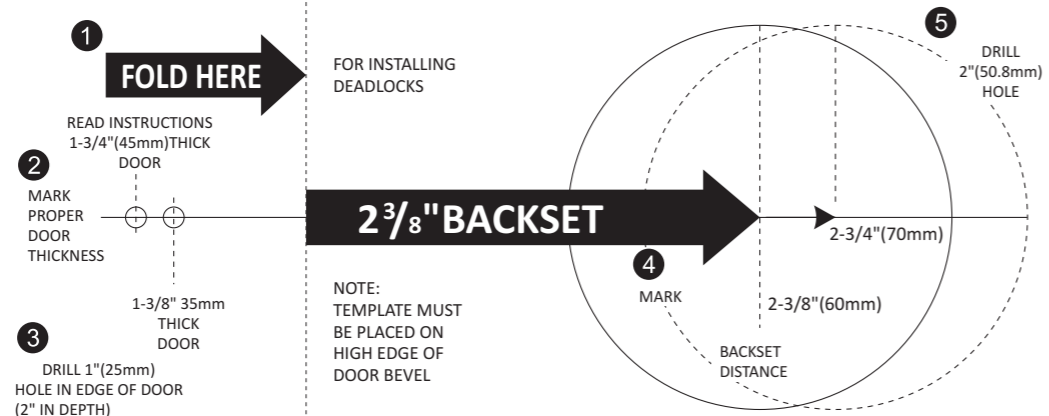

Selecting the Proper Backset

The backset is the distance from the door edge to the center of the hole

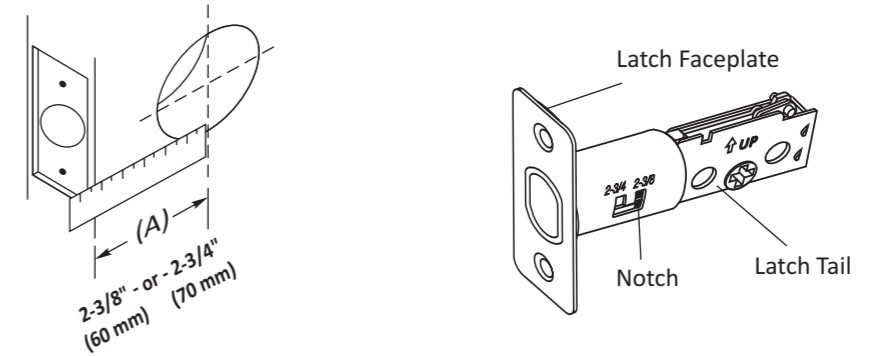

To adjust the backset from 2-3/8" to 2-3/4" follow these steps.

Retract the latch bolt.	Hold the latch tail and rotate the faceplate towards you.	Once the notch is in the groove, pull the latch faceplate away from the latch tail.	Rotate the latch faceplate away from you and check to see if the notch is at the 2-3/4" mark.

To adjust the backset from 2-3/4" to 2-3/8" follow these steps.

Retract the latch bolt.	Hold the latch tail and rotate the faceplate towards you.	Once the notch is in the groove, push the latch faceplate towards the latch tail.	Rotate the latch faceplate away from you and check to see if the notch is at the 2-3/8" mark.