

HBD5020X78

BARN DOOR HARDWARE KIT - STRAIGHT STRAP

For Doors up to 36" W
Rail Length: 78-3/4"



Available Finishes:



Black



Satin Nickel



Stainless

FEATURES:

- Meets ANSI/BHMA A156.14-2013 Grade 1; Durability Test 220 lb (100kg)
- POM Wheel - 2-3/4" Diameter
- Steel 1-1/4" Diameter Roller Bearings
- Track Size: 1/4" Steel, 1-1/2" x 78-3/4"
- Strap Size: 1/4" Steel, 11-3/4" X 1-1/2"
- Material (Black & Satin Nickel): Steel
(Stainless): Stainless Steel 304

BOM:

- Rail 78-3/4" Long, Pre-Drilled for Mounting (1)
- Rail Spacer (5)
- Rail Mount Lag Bolts M8 x 90mm (5)
- Rail Mount Washer M8 (5)
- Straight Strap Hangers (2)
- Hanger Bolts for 1-3/8" Door M10 x 1.5 x 55mm (4)
- Hanger Bolts for 1-3/4" Door M10 x 1.5 x 60mm (4)
- Hanger Bolt Washers M10 (8)
- Hanger Bolt Cap Nuts M10 (4)
- Mortised Door Guide (1) with Screws ST4.2 x 25mm (2) Anchor $\phi 6$ (2)
- Non-Mortised Door Guide (2) with Screws ST4.2 x 25mm (4) Anchor $\phi 6$ (4)
- Anti Jump Disk with Screws ST4 x 25mm (2)
- Rail Door Stops Standard (2)
- Allen Wrench M2 for Door Stops (1)

DRAWINGS:

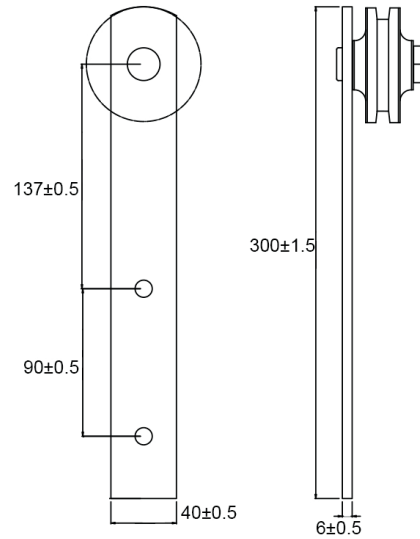

Straight Strap Hanger - Standard Wheel

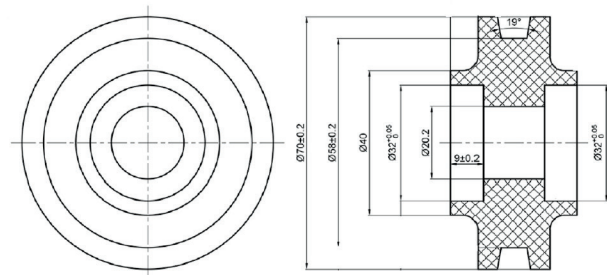

Standard Wheel

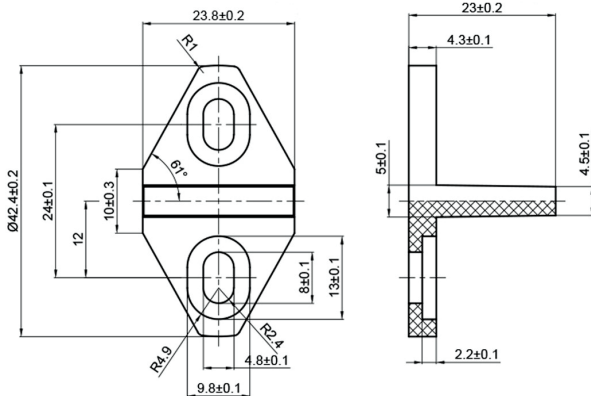

Mortise Floor Guide

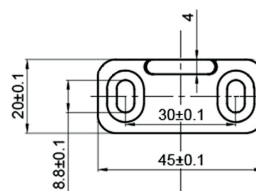

Non-Mortise Floor Guide

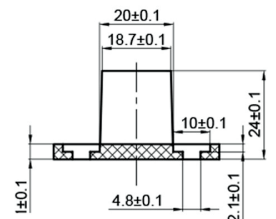

HBD5020X78

BARN DOOR HARDWARE KIT - STRAIGHT STRAP

DRAWINGS:

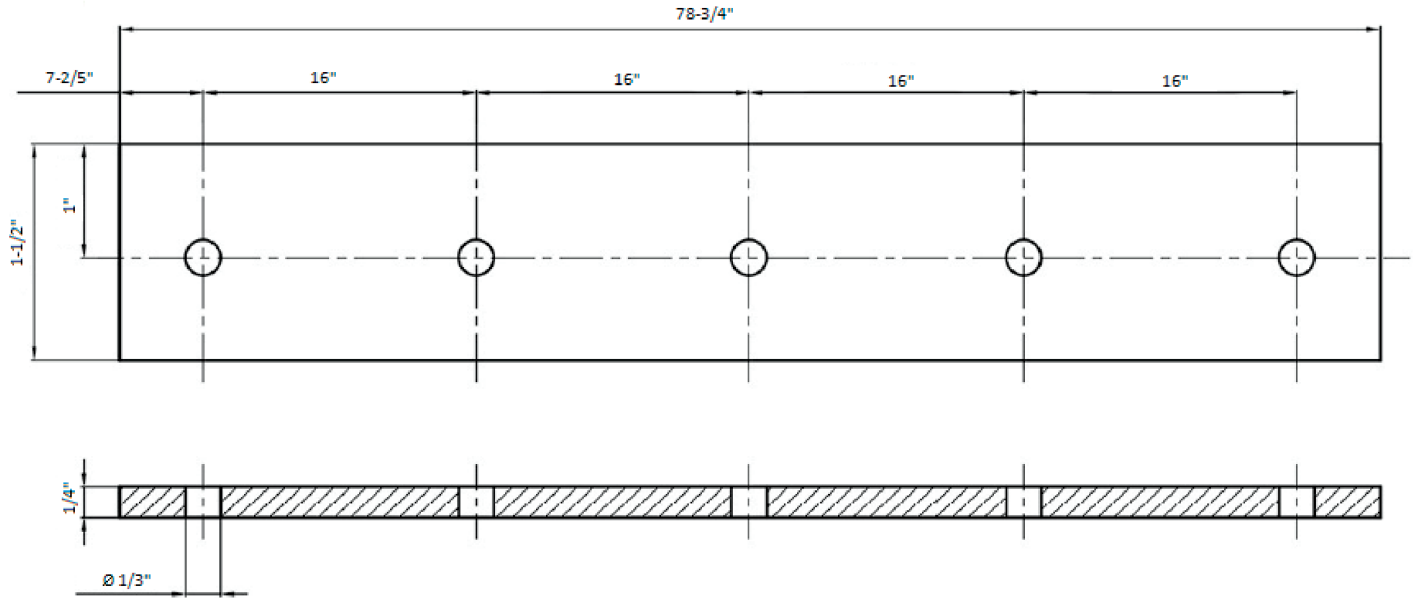

Flat Rail 78.75"

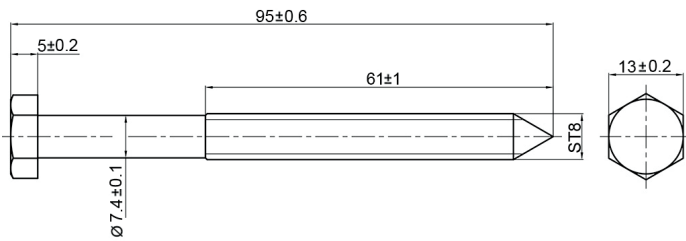

Track Lag Bolt

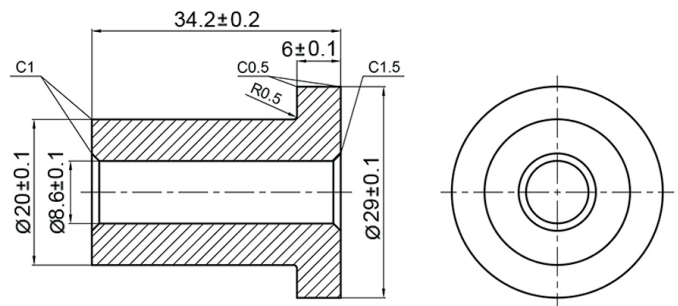

Flat Rail Spacer

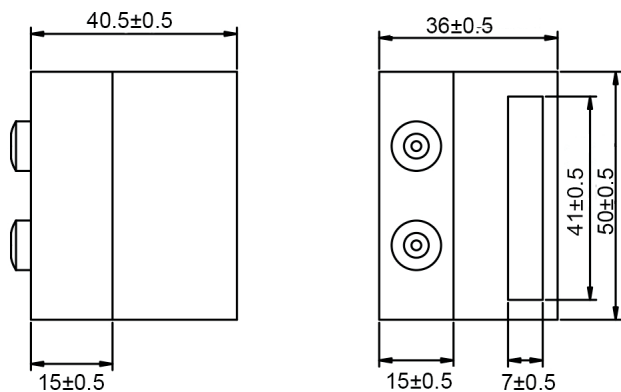

Flat Rail Stop Standard

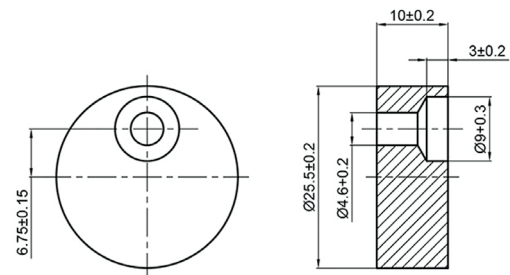

Anti Jump Disk