

OJV-45



Notes:

- Nous vous recommandons de bloquer l'arrivée d'eau et la conduite d'évacuation à la réception du meuble
- L'installation du meuble-lavabo devrait être confiée à un plombier expérimenté
- Le tuyau d'écoulement et le siphon ne sont pas inclus

Notes:

- We suggest you rough-in the water-lines and drain after receiving the unit
- The vanity should be installed by an experienced plumber
- Drain pipe and trap are not included

Instructions d'installation / Installation instructions

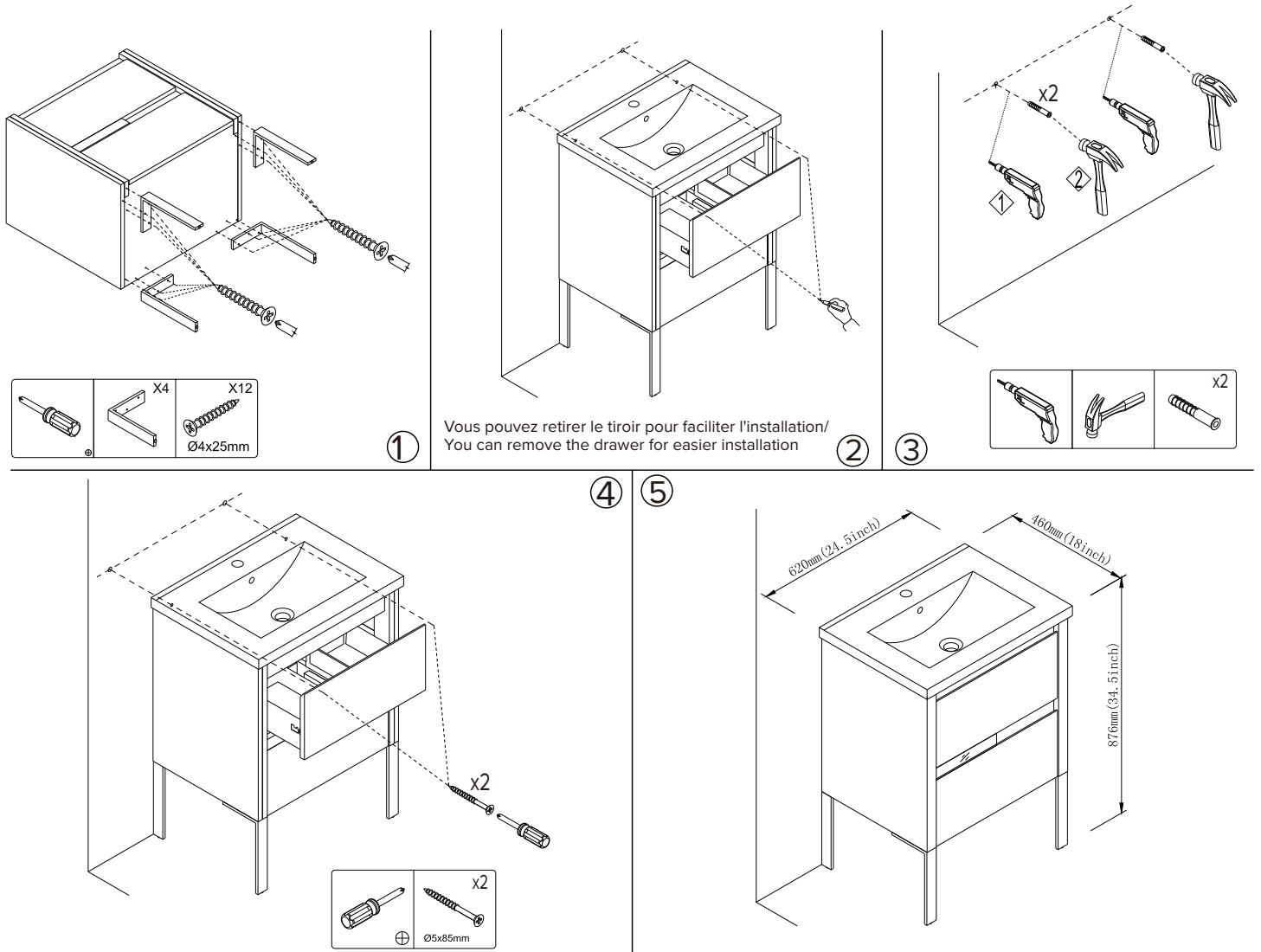

Cet article n'est plus garanti si installé avec un défaut visuel évident.

The warranty will be void if this item is installed with obvious visual defects.

LIMITED 1 YEAR WARRANTY

This warranty applies to MISENO vanities installed for commercial and residential use. MISENO warrants that, when installed in accordance with the Recognized Plumbing Industry Practice, the vanities are free of manufacturing defects for a period of one (1) year from the date of purchase.

We guarantee your satisfaction with each vanity. Should any vanity not meet your satisfaction due to a visual defect, simply return it to your retailer with the original packaging, PRIOR TO INSTALLATION, for a replacement.

INFORMATION ABOUT YOUR WARRANTY COVERAGE

This warranty does not cover damages or failure attributable to:

- Vanities installed with obvious visual defects.
- Defects or damages to vanities caused by installation that does not comply strictly with the instructions set forth in the MISENO vanities Recognized Plumbing Industry Practice.
- Defects or damage to vanities caused by severe accidents (e.g., fire, burns)
- Damage caused by flooding or standing water from leaking pipes, faucets, household appliances, etc; up to and including flooding and any damage caused by acts of God.

Notes on Warranty:

- This warranty applies only to the original purchaser and installation site and is not transferable.

FOR WARRANTY SERVICE

To make a claim, contact MISENO no later than 30 days following the date of discovery or detection of defect, at 1-855-480-2915. Proof of purchase, such as the bill of sale is mandatory when requesting warranty service.

- MISENO reserves the right to designate a representative to inspect the vanity for analysis.
- No unauthorized person, installer, dealer, agent or employee of MISENO or any representative is entitled to assume any liability on behalf of MISENO relating to the sale of this product or has the authority to increase or alter the obligations or limitations of this warranty.

CONSUMER RESPONSIBILITIES AND MAINTENANCE:

MISENO does not recommend the use of harsh abrasive cleansers on any of its products. Harsh cleansers will damage the countertops, metal and glass finish of your vanity.

For daily maintenance, use a wet cloth and a soft liquid cleaner. Never use abrasives or cleaners containing acetone, chlorine or strong bleach, scrapers, metallic brushes, nor other objects or products which can graze or tarnish surfaces.

An important part of granite or marble countertop maintenance is re-sealing your countertop to prevent cloudiness and permanent stains. It is necessary to reseal the counter every six months. Check with your installer or a local stone provider to get their recommendation. When you do re-seal, be sure to choose a non-toxic sealer.

THE SOLE REMEDY PROVIDED BY THIS WARRANTY IS THE REPAIR OR REPLACEMENT OF DEFECTIVE PRODUCTS. THIS WARRANTY DOES NOT COVER THE COST OF REMOVAL OR INSTALLATION OF NEW PRODUCT

THE WARRANTY WILL BE VOID IF THIS ITEM IS INSTALLED WITH OBVIOUS VISUAL DEFECTS.