

FNS 7794 E

PerfectCool freezer

with NoFrost and 8 freezer drawers on telescopic runners for max. convenience.



- Ice cubes thanks to the plumbed IceMaker
- Double the convenience with Miele's Ice&PizzaBox
- No icing up of food and no need to defrost thanks to NoFrost
- Optimum and maintenance-free LED lighting in compartment
- Soft closing of the door with SoftClose

EAN: 4002516480938 / Material number: 11911910 / Old Material Number: 37779400USA

Appliance category	
Freezer	•
Design	
Built-in	•
Built-in integrated	•
Door hinge side	Left
Convertible hinging	•
Can be installed side-by-side	•
Design	
Freezer compartment lighting	LED
IceMaker lighting	•
User convenience	
Networking with Miele@home	•
NoFrost	•
VarioRoom	•
SoftClose door closing damper	•
IceMaker with plumbed water connection	•
Control	
Electronic temperature display and control	FreshTouch
Independent temperature control of fridge and freezer compartments	No
SuperFrost	•
No. of temperature zones	1
Sabbath mode	•
Party mode	•
Freezer/freezer zone	
Number of freezer drawers	8
of which on runners	6
of which Ice&PizzaBox	2
Safety	
Lock function	•
Acoustic door alarm	•
Acoustic temperature alarm, freezer section	•
Optical door alarm	•
Optical temperature alarm	•
Power cut indication for freezer compartment	•
Technical data	
Niche width in inches (mm), min.	22 1/8 (560)
Niche width in inches (mm), max.	22 1/2 (570)
Niche height in inches (mm), min.	69 7/8 (1772)
Niche height in inches (mm), max.	70 1/2 (1788)
Niche depth in in.(mm)	21 3/4 (550)
Appliance width in in.(mm)	22 1/8 (559)
Appliance height in in.(mm)	69 3/4 (1770)
Appliance depth in in.(mm)	21 1/2 (544)
Weight in lbs.(kg)	157 (70.9)
Type of mounting	Fixed door
Maximum fridge compartment door front weight in lbs. (kg)	58 (26)
Maximum freezer compartment door front weight in lbs. (kg)	58 (26)

FNS 7794 E

PerfectCool freezer

with NoFrost and 8 freezer drawers on telescopic runners for max. convenience.



EAN: 4002516480938 / Material number: 11911910 / Old Material Number: 37779400USA

Climatic classification	SN-T
Storage time in case of fault in h	9
Voltage in V	120
Fuse rating in A	10
Number of phases	1
Frequency in Hz	50-60
Wire length in ft (m)	7 (2.2)
Replacing bulbs	Customer Service

FNS 7794 E PerfectCool freezer

with NoFrost and 8 freezer drawers on telescopic runners for max. convenience.

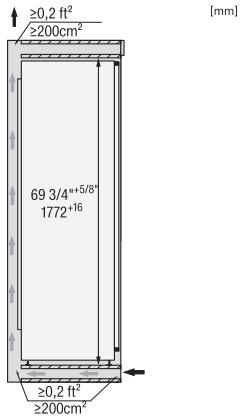

KS7793D, FNS7794E, side view (installation drawings) (US)

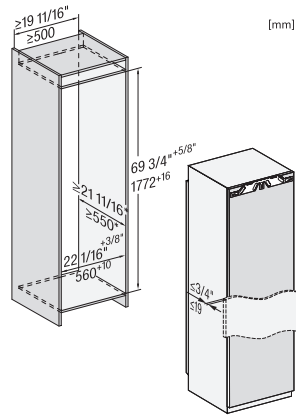

KS7793D, FNS7794E, built-in installation (*footnote) (installation drawings) (US)

*The declared energy consumption was calculated in a 560 mm deep niche. The appliance is fully functional in a 550 mm niche but the energy consumption will be slightly higher.

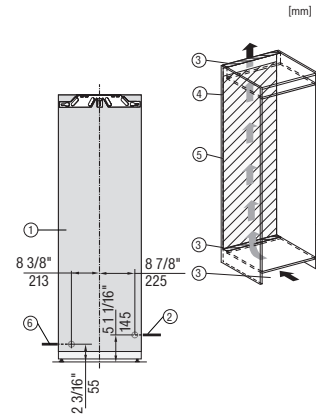

FNS7794E, installation (*footnote) (installation drawings) (US)

*1. View from the front, 2. Mains connection cable, L = 2100 mm, 3. Ventilation cut-out min. 200 cm², 4. Ventilation, 5. No connections permitted in this area, 6. Water connection L = 2000 mm