

MOCP215/MOCL215

15" CLEAR ICE MACHINE



MARVEL OUTDOOR COLLECTION

MAIN FEATURES

- Produces 3/4" clear ice cubes
- Produces up to 39 pounds of clear ice per day
- Stores up to 23 pounds of clear ice
- Ice scoop included with dedicated holder
- Door ajar and cleaning alerts
- Arctic white LED theater-style lighting
- Elegant midnight black interior
- Reversible door allows for right or left swing
- Designed for outdoor use

WARRANTY

- 1-year parts and labor warranty and 5-year sealed system parts warranty (see complete warranty for details)

FINISH OPTIONS



DOOR STYLE	PUMP	MODEL NUMBER
Solid Stainless Steel	Yes	MOCP215-SS01B
Solid Stainless Steel	No	MOCL215-SS01B



DIMENSIONAL DRAWINGS

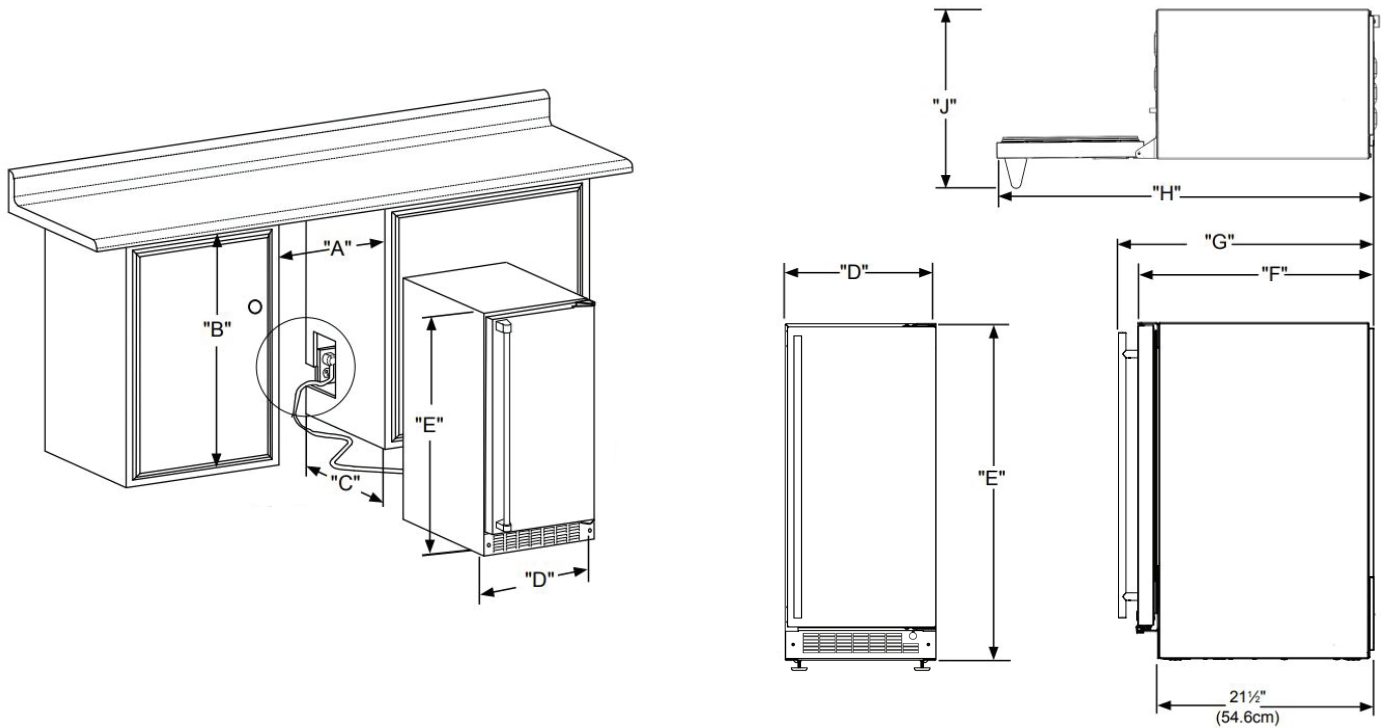

ROUGH IN DIMENSIONS*

"A"	"B"	"C"
15"	34" to 35"	24"
(38.1 cm)	(86.4 cm to 88.9 cm)	(61 cm)

CABINET DIMENSIONS*

"D"	"E"	"F"	"G"	"H"	"J"
14-7/8"	33-3/4" to 34-3/4"	23-5/8"	26-1/8"	37-3/8"	16-5/8"
(37.8 cm)	(85.7 cm to 88.3 cm)	(60 cm)	(66.3 cm)	(94.9 cm)	(42.2 cm)

*Stainless steel model dimensions only. For panel-ready models, see the owner's guide online at marvelrefrigeration.com.

PRODUCT SPECIFICATIONS

Capacity	23 LBS
Cord Length	6 FT.
Electrical Requirements	115V / 60 Hz / 15A
ENERGY STAR	No
Refrigerant Type	R600a
Sabbath Mode	Yes
Shipping Dimensions	25" W x 31" D x 37" H
Shipping Weight	160 LBS

