

Little GIANT®

VDS PIGGY-BACK VERTICAL DIAPHRAGM SWITCH



Features

- Heavy duty switch contacts
- Designed for use in confined areas
- Not sensitive to turbulence
- Controls pumps up to 1/2 HP at 120VAC, 13 amps max.
- UL listed and CSA certified for use in water and sewage
- Pressure activation
- Pumping range 6" or 10"
- Stainless steel mounting brackets

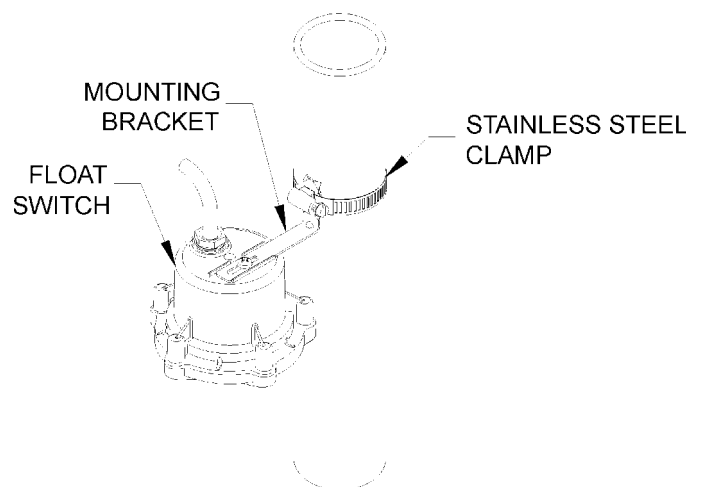

The vertical diaphragm switch provides automatic control of a pump in water and sewage effluent applications. The design allows it to operate in applications with limited space, such as small sump chambers. The VDS features models with either a 6" or 10" pumping range.

VDS

PIGGY-BACK VERTICAL DIAPHRAGM SWITCH

Typical Installation

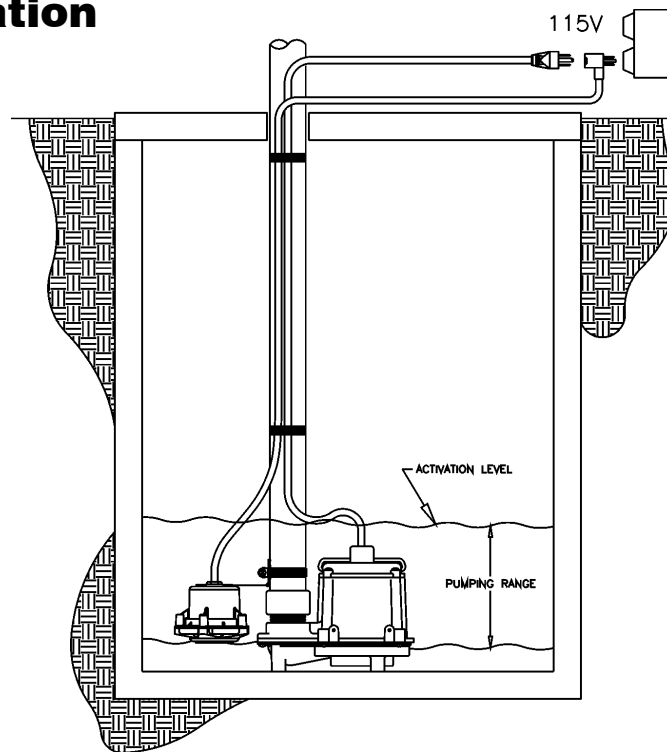

Specifications

Item No.	Model No.	Listings	Volts	Max. Amps	Pumping Range	Cord Length	Voltage 50Hz/60Hz Single Phase	Maximum Pump Running Current	Recommended Pump HP
599165	VDS1006	UL/CSA	115	13.0	6"	10'	120 VAC	13 Amps	1/2 HP or less
599166	VDS1506	UL/CSA	115	13.0	6"	15'	120 VAC	13 Amps	1/2 HP or less
599167	VDS2010	UL/CSA	115	13.0	10"	20'	120 VAC	13 Amps	1/2 HP or less
599168	VDS1010	UL/CSA	115	13.0	10"	10'	120 VAC	13 Amps	1/2 HP or less
599169	VDS1510	UL/CSA	115	13.0	10"	15'	120 VAC	13 Amps	1/2 HP or less

Construction

Cable	Flexible 14 gauge, 2 conductor SJTW (UL & CSA) water resistant, neoprene (CR)
Mounting Bracket & Hose Clamp	Stainless steel
Float Housing	Impact resistant, non-corrosive, thermal-plastic for use in liquids up to 140°F (60°C)