

Little Giant®

SP-14



Features

- Ideal for sump and drainage applications
- 10' Power Cord
- Handles up to 3/16" solids
- 1/4 HP thermally protected motor, oil filled for lifetime lubrication
- 1-1/2" FNPT discharge
- Minimum basin size 18" diameter x 24" deep
- ON Level: 12" - 14"
OFF Level: 5" - 7"

Construction

- Motor — 1/4 HP shaded pole
- Flow Rate — 32 GPM @ 5'
- Maximum Head — 22'
- Intermittent Liquid Temp. up to 120° F
- Discharge — 1-1/2" FNPT
- Housing — Cast iron
- Volute — ABS
- Impeller — Nylon, glass-filled
- Shaft Seal — Carbon/Ceramic
- Electrical — 115V, 60Hz, 7.6A, thermal overload protection

This pump is designed to provide efficient, trouble-free service in moving large volumes of water. Applications include excavation site, crawl space, basements, underground passageways, loading docks, construction sites among others.

SP-14

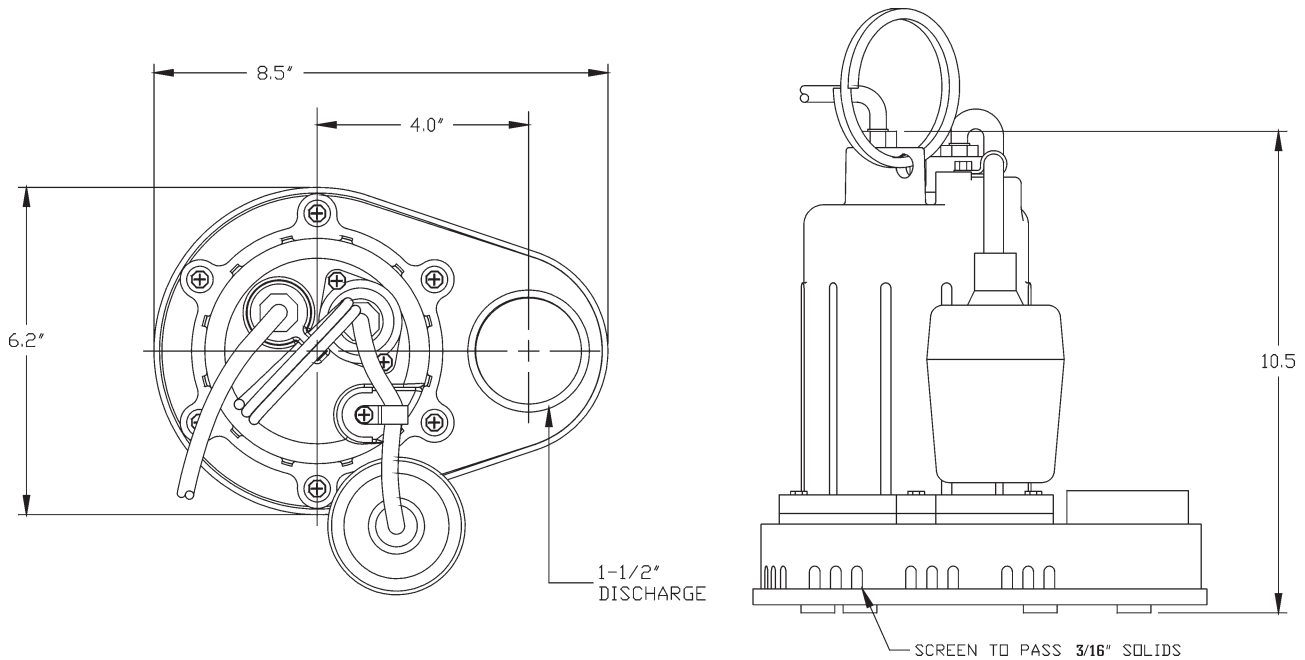

Specifications

Model No.	Item No.	Discharge	Listings	HP	Volts	Hertz	Amps	Watts	Performance (GPM @ Head)				Shut Off Feet	PSI	Pwr. Cord (ft.)	Weight (lbs.)	Height	Length	Width
									5'	10'	15'	20'							
SP-14	577101	1-1/2" FNPT	UL/CSA	1/4	115	60	7.6	560	32	25	17	5	22	9.5	10	16.00	10.5	8.5	6.2

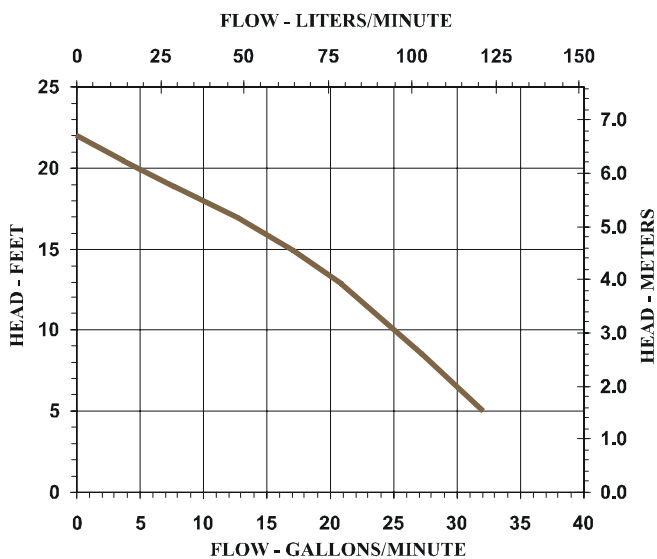

SP-14 Series

Head (ft.)	Flow (GPM)	Head (m)	Flow (LPM)
5	32	1.5	121
10	25	3.0	95
15	17	4.6	64
20	5	6.1	19
22	0	6.7	0

Little Giant Pump Co.

PO Box 12010
Okla. City, OK 73157

Phone: 405.947.2511
Fax: 405.228.1550

www.LittleGiant.com