

PONY PUMP REPAIR KIT

INTRODUCTION

This instruction sheet provides you with the information required to safely own and operate your product. Retain these instructions for future reference.

The product you have purchased is of the highest quality workmanship and material, and has been engineered to give you long and reliable service. This product has been carefully tested, inspected, and packaged to ensure safe delivery and operation. Please examine your item(s) carefully to ensure that no damage occurred during shipment. If damage has occurred, please contact the place of purchase. They will assist you in replacement or repair, if required.

READ THESE INSTRUCTIONS CAREFULLY BEFORE ATTEMPTING TO INSTALL, OPERATE, OR SERVICE YOUR PRODUCT. KNOW THE PRODUCT'S APPLICATION, LIMITATIONS, AND POTENTIAL HAZARDS. PROTECT YOURSELF AND OTHERS BY OBSERVING ALL SAFETY INFORMATION. FAILURE TO COMPLY WITH THESE INSTRUCTIONS COULD RESULT IN PERSONAL INJURY AND/OR PROPERTY DAMAGE!

SAFETY GUIDELINES

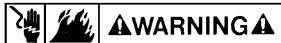

WARNING: Disconnect the pump and all submerged electrical components before performing any operation in the water. If the plug or socket is wet, disconnect the breaker before removing the power cord.

Do not use to pump flammable or explosive fluids such as gasoline, fuel oil, kerosene, etc. Do not use in explosive atmospheres. Pump should only be used with liquids compatible with pump component materials.

Do not handle pump with wet hands or when standing on a wet or damp surface or in water.

For DC (direct current) versions, when attaching pump leads to battery terminals, be sure that the area is adequately ventilated to prevent an explosion or fire from explosive or flammable vapors that may be present. Consult the battery manufacturer for additional safety information.

Batteries emit hydrogen gas, which is explosive. Avoid smoking, sparks, or open flame anywhere in batteries' vicinity.

Explosion from battery can cause blindness. Shield eyes when working near any battery.

Batteries contain sulfuric acid. In case of contact with eyes, skin or clothing, flush immediately with large amounts of water and get medical attention.

Do not add acid or electrolyte to a battery.

Keep out of reach of children.

ELECTRICAL CONNECTIONS



1. Check the pump label for proper voltage required. Do not connect to voltage other than that shown.
2. For DC (direct current) versions, when using a battery as the power source, attach the red positive (+) lead wire to the positive (+) battery terminal, followed by attaching the black negative (-) lead wire to the ground (-) battery terminal. When disconnecting the pump, first disconnect the black negative

(-) lead wire from the battery ground (-) terminal, and then disconnect the red positive (+) lead wire from the positive (+) battery terminal.

3. To operate properly, the DC (direct current) version pump must be connected to a steady DC power source or a battery in good condition supplying the proper voltage according to the pump label. Low voltage power source may cause critical overheating and premature failures. To avoid this condition, be sure proper voltage is maintained.

MAINTENANCE



CAUTION: Disconnect the pump from the power source when making adjustments and repairs. On DC (direct current) versions, first disconnect the black negative (-) lead wire, and then disconnect the red positive (+) lead wire.

1. **TO REPLACE IMPELLER:** Replace impeller when it has become worn or damaged.
 - a. Remove 4 volute cover mounting screws (1).
 - b. Remove volute cover (2) and gasket (3).
 - c. Slide impeller (4) off motor shaft.
 - d. Clean the inside of the pump head and the gasket sealing surface. Make certain that there are no foreign materials that would obstruct the impeller's operation.
 - e. Apply petroleum jelly or similar lubricant to the inside of the pump head using cotton swab. Do not get lubricant on gasket sealing surface; this surface must be lubricant-free.
 - f. Align the flat on the inside of the impeller (4) shaft bore with the flat on the motor shaft. Push the impeller into place, while twisting the impeller vanes in a clockwise rotation.
 - g. Place new gasket (3) onto pump head face, align holes, and replace cover (2).
 - h. Tighten cover mounting screws (1) evenly and snugly.
2. **TO REPLACE CAM:** Replace cam (5) when it has become worn or damaged.
 - a. Remove impeller (4) according to step 2.
 - b. Remove handle mounting screw (not shown) and handle.
 - c. Remove cam screw (7) and cam screw gasket (6).
 - d. Gasket sealant is used between cam and pump head, and will require that the cam be pried from pump head. Be careful not to damage the cover gasket sealing surface.
 - e. Clean the gasket sealant from the pump head.
 - f. Apply gasket sealant to new cam (5) and mating surface of pump head.
 - g. Install new cam into pump head. Install new cam screw gasket (6) and secure new cam with new cam screw (7). Tighten new cam screw snugly to prevent leakage.
 - h. Clean any excess gasket sealant from pump head.
 - i. Reinstall handle and handle mounting screw.
 - j. Install impeller (4) according to step 2.
3. **TO REPLACE SHAFT SEAL:** Replace shaft seal (8) when it has become worn or damaged.
 - a. Remove pump head mounting screws (not shown) and slide pump head off of motor shaft. Do not remove slinger washer (11) from motor shaft.
 - b. Pry retaining ring (10) from the backside of the pump head.

- c. Remove the felt washer (9) and shaft seal (8) from seal bore in the pump head.
- d. Install new shaft seal and new felt washer into seal bore in the pump head.
- e. Press new retaining ring (10) into seal bore in the pump head.
- f. Place pump head onto motor shaft, carefully aligning the shaft seal inside diameter with motor shaft. There is a flat on the motor shaft and a mating flat on the impeller inside diameter. To fully seat the pump head onto the motor, the flats on the motor shaft and the impeller must be aligned. Rotate the pump head until the flats align and the pump head can be fully seated onto the face of the motor.
- g. Align the pump head mounting holes with the mounting holes on the face of the motor. Reinstall the pump head mounting screws, tightening them evenly and snugly.

Repair Kits			
555702 HRK-360S	555706 IRK-360	555713 IRK-360S	555714 ISRK-360S

Item	Description	Component Quantity			
		555702 HRK-360S	555706 IRK-360	555713 IRK-360S	555714 ISRK-360S
1	Screw, volute cover	4	--	--	--
2	Volute cover, SST	1	--	--	--
3	Cover gasket, Nitrile	2	2	2	2
4	Impeller, Buna-N w/SST insert	2	--	2	2
4	Impeller, Buna-N w/brass insert	--	2	--	--
5	Cam, SST	1	--	--	--
6	Gasket, fiber washer, cam screw	1	--	--	--
7	Screw, cam	1	--	--	--
8	U-cup seal, Viton	--	--	--	1
9	Felt washer	--	--	--	1
10	Internal retaining ring	--	--	--	1
11	Slinger washer, neoprene	--	--	--	1

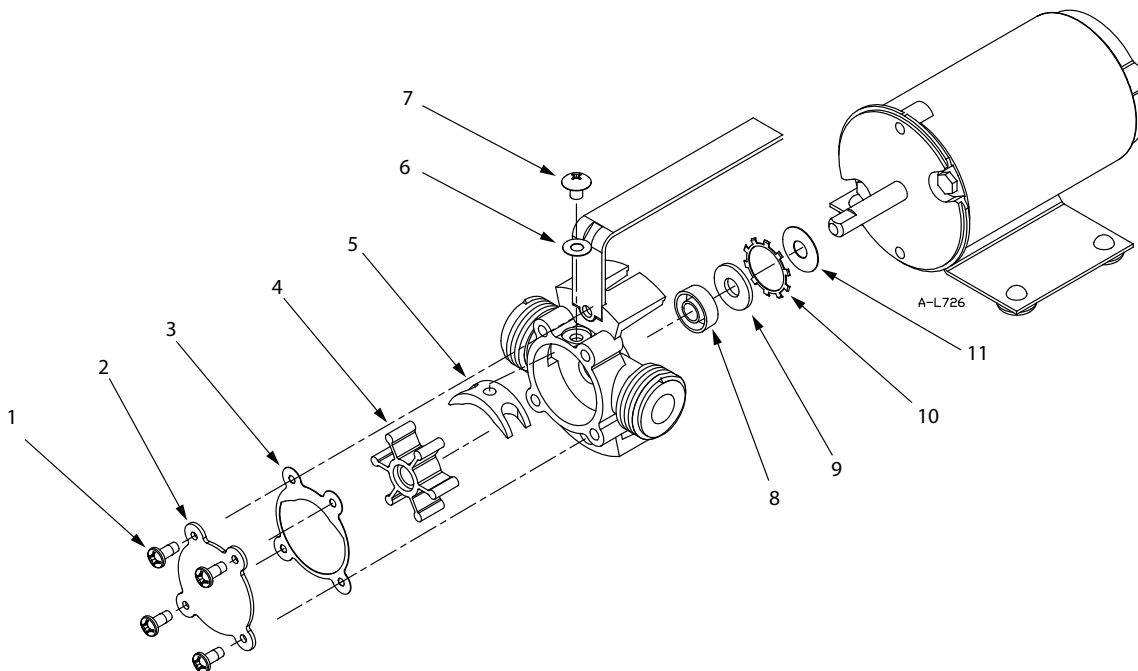

TROUBLESHOOTING

PROBLEM	PROBABLE CAUSES	CORRECTIVE ACTION
Pump will not run	<ol style="list-style-type: none"> 1. No power or incorrect voltage 2. Brushes worn out 3. Motor has open circuit 4. Motor overheated 	<ol style="list-style-type: none"> 1. Supply correct voltage 2. Replace defective part 3. Replace defective part 4. If motor has auto-resetting thermal protector, wait 15 minutes for motor to cool
Pump runs but no fluid is pumped	<ol style="list-style-type: none"> 1. Air leak or kink in hose 2. Defective cam or impeller 3. Suction lift too high 4. Inlet clogged 5. Pump too far from liquid 	<ol style="list-style-type: none"> 1. Repair or replace 2. Replace defective part 3. Lower pump 4. Clean inlet 5. Relocate pump
Pump will not prime or retain prime after operating	<ol style="list-style-type: none"> 1. Air leak or kink in hose 2. Defective cam or impeller 3. Seal worn 4. Gasket leaking 5. Groove worn in shaft at seal area 6. Suction lift too high 	<ol style="list-style-type: none"> 1. Repair or replace 2. Replace defective part 3. Replace defective part 4. Replace defective part 5. Replace defective part 6. Lower pump
Flow rate is low	<ol style="list-style-type: none"> 1. Air leak or kink in hose 2. Defective cam or impeller 3. Incorrect voltage 4. Inlet clogged 	<ol style="list-style-type: none"> 1. Repair or replace 2. Replace defective part 3. Supply correct voltage 4. Clean inlet
Shaft seal leaks	<ol style="list-style-type: none"> 1. Seal worn 2. Groove worn in shaft at seal area 3. Pump head loose on motor 	<ol style="list-style-type: none"> 1. Replace defective part 2. Replace defective part 3. Repair
Motor runs too hot	<ol style="list-style-type: none"> 1. Incorrect voltage 2. Excessive discharge pressure 3. Impeller swollen 4. Liquid too viscous 5. Obstruction or kink in hose 6. Insufficient air flow on motor 	<ol style="list-style-type: none"> 1. Supply correct voltage 2. Reduce pressure 3. Replace defective part 4. Reduce viscosity of liquid 5. Repair or replace 6. Be sure ample fresh air is available at the motor

For parts or repair, please contact 1.888.572.9933
For technical assistance, please contact 1.888.956.0000

www.LittleGiantPump.com
CustomerService-WTS@fele.com
