

Little GIANT®

JUNCTION BOX ALARM KIT

FOR USE WITH AUTOMATIC GRINDER PUMPS



Features

- NEMA 4X non-corrosive PVC enclosure
- Hinged cover for convenience
- 25 Amp pump circuit breaker
- 3 Amp alarm circuit breaker
- PVC enclosure is resistant to moisture, wind, flame, and ultra-violet rays
- Separate alarm and pump control circuitry provided on terminal strip
- Flashing alarm beacon
- 20' alarm float switch

The Little Giant Junction Box Alarm Kit is used in conjunction with the automatic grinder. It provides a reliable means of connecting the pump to a power source in a non-corrosive weatherproof enclosure. The junction box contains a 25 Amp pump circuit breaker, 3 Amp alarm circuit breaker, a labeled terminal block, and a flashing alarm beacon. The kit also includes a 20' alarm float switch.

JUNCTION BOX ALARM KIT

Model No.	Item No.
JBAK	513297

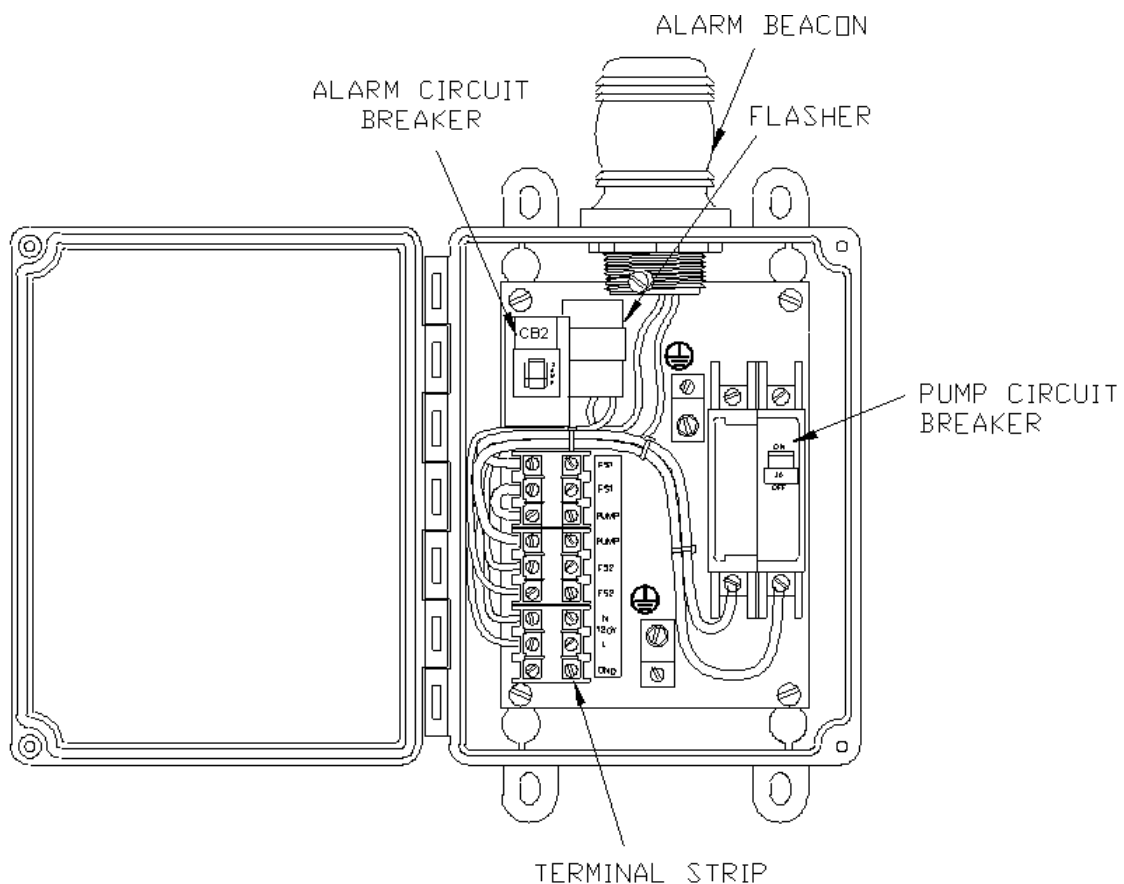
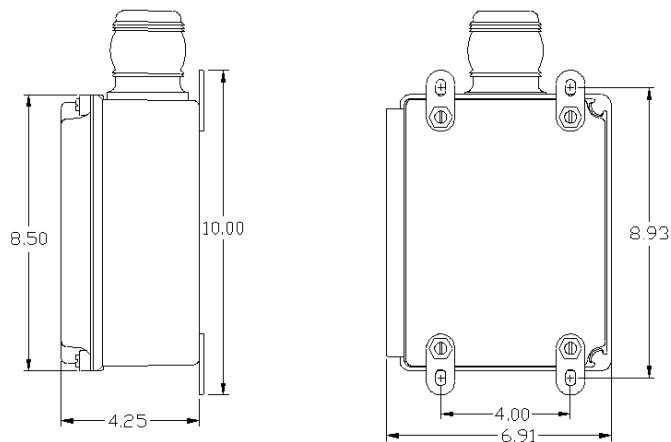

NOTE: Little Giant Pump Co. cannot be responsible for damages caused by faulty or negligent installation of this control. We recommend that you engage the services of a competent plumber, electrician, or qualified service person to install this product in accordance with national and local electrical codes.