

INTRODUCTION

Little Giant pumps are carefully packaged, inspected and tested to insure safe operation and delivery. When you receive your pump, examine it carefully to determine that there are no broken or damaged parts that may have occurred during shipment. If damage has occurred, make notation and notify the firm you purchased the pump from. They will assist you in replacement or repair, if required.

SAFETY GUIDELINES



WARNING: Risk of electric shock. This pump is supplied with a grounding conductor and grounding-type attachment plug. To reduce the risk of electric shock, be certain that it is connected only to a properly grounded, grounding-type receptacle.

1. Read all instructions and safety guidelines thoroughly. Failure to follow the guidelines and the instructions could result in serious injury and/or property damage.
2. Check local electrical and building codes before installation. The installation must be in accordance with their regulations.
3. During normal operation the sump pump is immersed in water. Also, during rain storms, water may be present in the surrounding area of the pump. Caution must be used to prevent bodily injury when working near the pump:
 - a. The plug must be removed from the receptacle prior to touching, servicing or repairing the pump.
 - b. To minimize possible fatal electrical shock hazard, extreme care should be used when changing fuses. Do not stand in water while changing fuses or insert your finger into fuse socket.
4. Do not run the pump in a dry sump. If the pump is run in a dry sump, the surface temperature of the pump will rise to a high level. This high level could cause skin burns if the pump is touched and will cause serious damage to your pump.
5. Do not oil the motor. The pump housing is sealed. A high grade dielectric oil devoid of water has been put into the motor housing at the factory. Use of other oil could cause serious electric shock and/or permanent damage to the pump.
6. This pump's motor housing is filled with a dielectric lubricant at the factory for optimum motor heat transfer and lifetime lubrication of the bearings. Use of any other lubricant could cause damage and void the warranty. This lubricant is non-toxic; however, if it escapes the motor housing, it should be removed from the surface quickly by placing newspapers or other absorbent material on the water surface to soak it up, so aquatic life is undisturbed.
7. In any installation where property damage and/or personal injury might result from an inoperative or leaking pump due to power outages, discharge line blockage, or any other reason, a backup system(s) and/or alarm should be used.

LITTLE GIANT QUALITY

Every pump has been factory tested for capacity, control operation and electrical continuity to assure maximum performance and safety. Little Giant automatic sump pumps have a high volume pumping capacity with a pressure activated switch. The switch engages in 8-1/2"–12" of water. Other pumps are available in epoxy coated cast iron housings or corrosion resistant cast bronze. Maximum operating temperature is 120°F.

The motor section of your pump is permanently lubricated and sealed - do not attempt to open this section. Special equipment and knowledge is required for proper servicing of this part of your pump and may only be accomplished by an Authorized Service Center or the factory. Your warranty will be void if the motor section is opened by unauthorized persons.

ELECTRICAL CONNECTIONS



Your sump pump is supplied with a 3-prong electrical plug (see Figure 1). The third prong is to ground the pump to prevent possible electric shock hazard. Do not remove the third prong from the plug. A separate branch electrical circuit is recommended. Do not use an extension cord.

Figure 1.

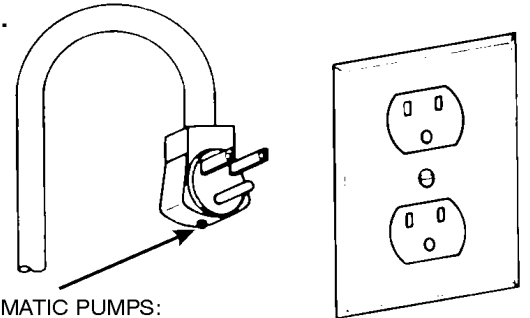

FOR AUTOMATIC PUMPS:
PROPER PLUG INSTALLATION
IS VENT TUBE DOWN.

INSTALLATION

1. Clean any debris from sump pit and set pump in center of pit. A solid bottom will prevent clogging of the pump from sand and dirt.
2. Connect discharge piping and run it to the nearest sewer or surface outlet. Use pipe joint compound at all connections. Sump pumps can be piped to discharge into the house drainage system, to a dry well, splash block or to a storm drain, depending on local plumbing codes. The discharge pipe should be as short as possible and contain as few elbows as possible. The discharge pipe should be the same diameter as the discharge size to reduce pipe friction losses. Smaller pipe will restrict capacity and reduce pump performance. The sump pump comes with 1-1/2" female pipe thread discharge.
3. Always install a union in the discharge line, just above the sump pit, to allow for easy removal of the pump for cleaning or repair.
4. In situations where the piping is long, the vertical discharge is above 7 or 8 feet, or a small pit has been provided, use of a check valve is recommended to prevent backflow of water into the sump. When a check valve is used, drill a relief hole (1/8" or 3/16" diameter) in the discharge pipe. This hole should be located below the floor line between the pump discharge and the check valve. Unless such a relief hole is provided, the pump could "air lock" and will not pump water even though it will run.

5. Tape power cord to discharge line with electrician's tape. This will protect the cord from damage and will prevent the pump's being pulled from the sump by its power cord.
6. TEST THE PUMP AFTER ALL CONNECTIONS HAVE BEEN MADE. Run water into sump. Do not attempt to operated the pump without water; this will damage the seals and bearings and could result in permanent damage to the pump. Fill sump to normal "on" level and allow pump to remove water to the normal "off" level (see Figure 2).
7. Place cover over sump. This cover will prevent solid debris from filling the pit, prevent odors, and guard against accidental injury.

WARNING: Always disconnect the electrical power before touching the pump or discharge when water is present in the sump. Failure to do so can result in hazardous electrical shock.

TYPICAL INSTALLATION FOR AUTOMATIC SUMP PUMPS

Figure 2.

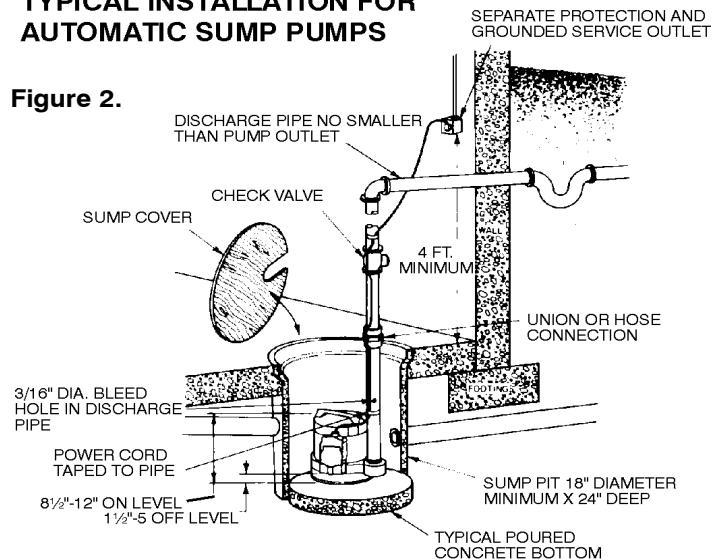

TROUBLESHOOTING INFORMATION • INFORMATION SUR LA RELÈVE DES DÉRANGEMENTS • INFORMACION DE INVESTIGACION DE AVERIAS		
PROBLEM • FONCTIONNEMENT DÉFECTUEUX • PROBLEMA	PROBABLE CAUSES • CAUSES PROBABLES • CAUSAS PROBABLES	CORRECTIVE ACTIONS • SOLUTIONS • SOLUCION
Pump will not shut off. NOTE: Before troubleshooting automatic control, check to see that pump operates on manual control. To do this, create slight vacuum on breather tube (near plug), then close off tube with thumb, plug into wall outlet. If pump works, proceed to check switch; if not, fault is in pump or power supply.	Diaphragm switch.	Replace switch.
	Weak or hardened rubber diaphragm.	Replace rubber diaphragm.
	Plugged vent tube.	Clear vent tube of any obstruction.
	Dirt or sediment lodged between retainer ring and rubber diaphragm causing contacts to remain closed.	Clean area around rubber diaphragm.
	Pump is air locked.	Shut power off for approximately 1 minute, then restart. Repeat several times to clear air from pump. If system includes a check valve, a 3/16" hole should be drilled in discharge pipe approximately 2" above discharge connections.
	Liquid inflow matches pump capacity.	Larger pump required.
	Defective switch.	Disconnect switch, check w/ohmmeter. Open-infinite resistance, closed zero.
Pump runs, but does not discharge liquid.	Loose connection in level control wiring.	Check control wiring.
	Check valve installed backwards.	Check flow indicating arrow on check valve body to ensure it is installed properly.
	Check valve stuck or plugged.	Remove check valve and inspect for proper operation.
	Lift too high for pump.	Check rating table.
	Inlet to impeller plugged.	Pull pump and clean.
Pump does not deliver rated capacity.	Pump is air locked.	(See corrective action above).
	Lift too high for pump.	Check rated pump performance.
	Low voltage, speed too slow.	Check for proper supply voltage to make certain it corresponds to nameplate voltage.
	Impeller or discharge pipe is clogged.	Pull pump and clean. Check pipe for scale or corrosion.
Pump cycles continually.	Impeller wear due to abrasives.	Replace worn impeller.
	No check valve in long discharge pipe allowing liquid to drain back into sump.	Install a check valve in discharge line.
	Check valve leaking.	Inspect check valve for correct operation.
	Sump pit too small for inflow.	Install a larger sump pit.

Figure 3.

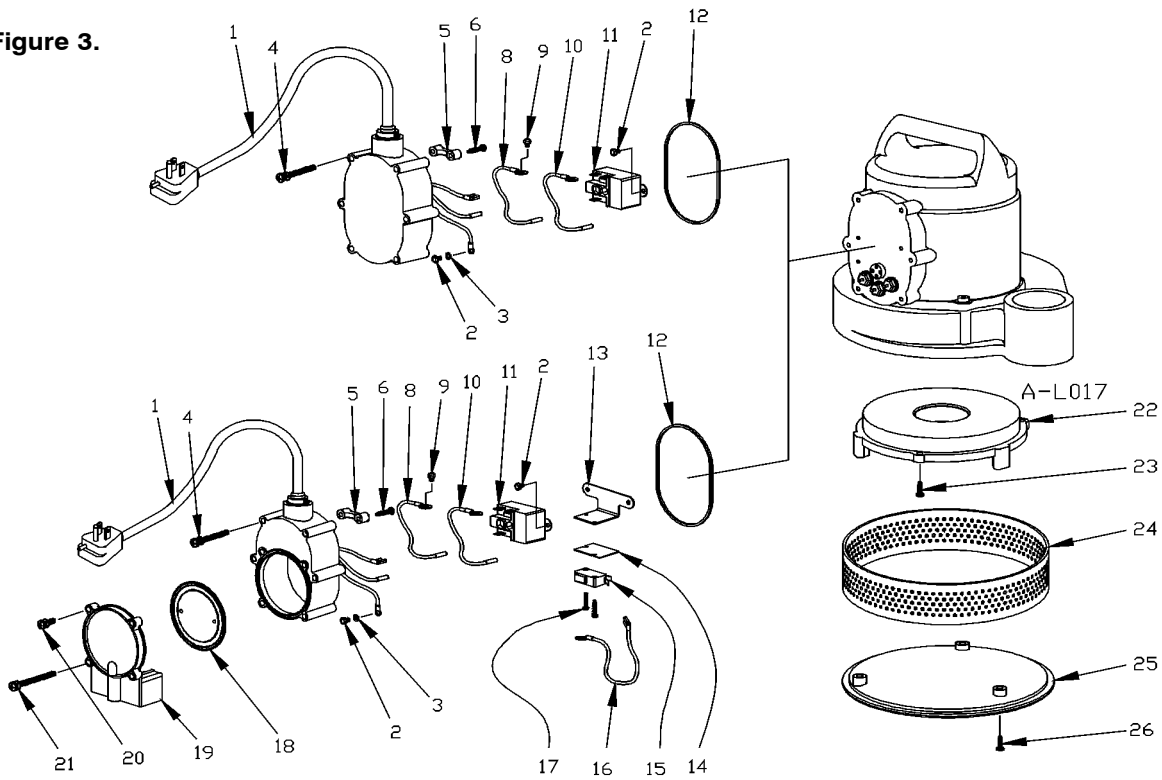

REPLACEMENT PARTS LIST

ITEM NO.	PART NO.	DESCRIPTION	10-CJM 510055	10-CIA 510155	10-CIA 510156	12-CBM 512055	12-CBA 512155
1	111704	Housing, Manual Switch Assembly, 10' (115V)	•				
1	111705	Housing, Automatic Switch Assembly, 10'		•			•
1	111706	Wiring Harness Assembly, with Tube, 25'			•		
2	902307	Screw, Tap #6-32 x 1/4"	3	3	3	3	3
3	921028	Washer, Lock #6	•	•	•	•	•
4	909025	Screw/Washer #10-24 x 1-3/4" (SST)	6	4	4		
	909033	Screw/Washer #10-24 x 1-3/4" (brass)				6	4
5	112120	Clamp, Strain Relief	•	•	•	•	•
6	902409	Screw, Tap, 8-18 x 3/4"	2	2	2	2	2
8	951964	Lead Wire, Red	•	•	•	•	•
9	901306	Screw, #6-32 x 3/16"	3	3	3	3	3
10	951963	Lead Wire, Black	•	•	•	•	•
11	950930	Relay	•	•	•	•	•
12	928019	Seal Ring	•	•	•	•	•
13	112121	Bracket, Switch Relay	•	•	•	•	•
14	112119	Pad, Insulating	•	•	•	•	•
15	950323	Switch, Miniature	•	•	•	•	•
16	951976	Lead Wire, Black	•	•	•	•	•
17	909034	Screw/Washer, #4-40 x 9/16"		2	2		2
18	108125	Diaphragm		•	•		•
19	108055	Cover, Switch Housing		•	•		•
	909022	Screw/Washer #10-24 x 5/8"		2	2		
20	901521/ 921002	Screw/Washer #10-24 x 5/8" (bronze)					2
	901523/ 921023	Screw/Washer #10-24 x 2-1/8"		2	2		
21	901528/ 921002	Screw/Washer #10-24 x 2-1/8" (bronze)					2
	110033	Base	•	•	•		
	112033	Base				•	•
	909021	Screw/Washer #10-24 x 1/2" (SST)	3	3	3		
	909009	Screw/Washer #10-24 x 1/2" (brass)				3	3
24	110082	Screen, Intake	•	•	•		
	112082	Screen, Intake (brass)				•	•
	110092	Plate, Screen	•	•	•		
	112092	Plate, Screen (bronze)				•	•
	909023	Screw/Washer #10-24 x 3/4"	3	3	3		
26	909019	Screw/Washer #10-24 x 3/4" (brass)				3	3

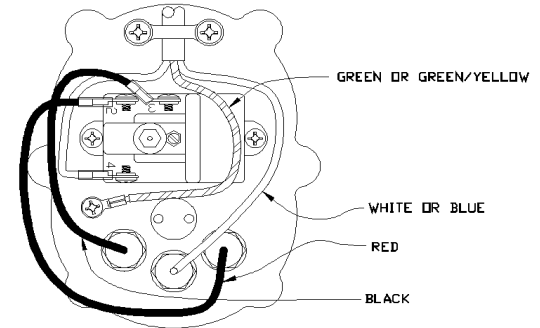

MANUAL PUMP MODELS

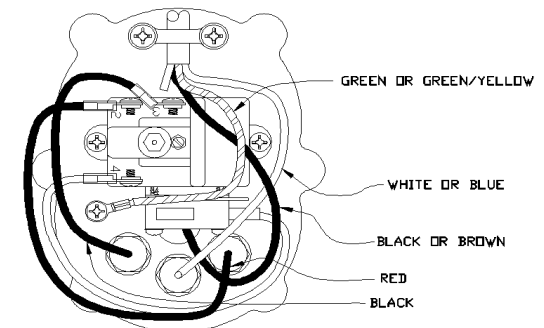

AUTOMATIC PUMP MODELS

ONE YEAR LIMITED WARRANTY

For one year from date of purchase, Little Giant Pump Company will repair this pump if defective in material or workmanship. Warranty service is available through a nationwide network of warranty service stations or by returning the pump prepaid to the factory. For further details, please consult the warranty statement on carton. This warranty gives you specific legal rights, and you may also have others rights which may vary from state. to state.

For Parts or Repair, please contact.....1.888.572.9933
For Technical Assistance, please contact.....1.888.956.0000

www.LittleGiant.com
customerservice@lgpc.com
