

ASSEMBLY INSTRUCTIONS FOR 9S-SMPX-LG 10S-SMPX-LG (BOLT-ON VENT/DISCHARGE FLANGES)

PRE-PACKAGED UNIT (Figure 1):

Verify all parts with basin and cover assemblies are received intact. The flanges provided will allow the following discharge/vent combinations to be used: 3" discharge/2" vent, or a 2" discharge/2" vent, depending on cover configuration.

1. Remove bolts and washers in cover and set aside.
2. Remove gasket material from hardware kit and place material around circumference of basin inside of bolt circle.
3. Place the pump on a flat surface and install the discharge pipe in the discharge of the pump.
4. Install float switch 4" above discharge of pump with a 3-1/2" tether length. Float switch should be installed in a manner that will not allow it to contact the pump or side of basin during operation. Refer to float switch instruction manual for alternative settings. Place the pump in the basin in the torque stops.
5. To install the two-piece cover, pull the pump and float cords through the smallest hole in the cover. Place the two-piece cover on the basin, making sure the discharge pipe is through the proper hole in the cover (holes are labeled on bottom of cover). Secure the lid to the basin, using the bolts and washers provided, making sure the bolts attaching the two pieces together are also tight. Place the larger square-cut O-ring on discharge pipe with beveled edge down. Install flange and tighten bolts. Place the remaining O-ring in the bottom of the vent flange with beveled edge down. Install flange and tighten bolts.
6. Pull the slack out of the cords and install them through the grommet 1-2 inches above the cover. Press the grommet in the hole in the cover.
7. Install a 2" vent pipe by threading it on the vent flange. Make sure the flange bolts are tight.

PRE-ASSEMBLED UNIT (Figure 2):

The pre-assembled unit is furnished fully assembled and ready for installation. Remove check valve from discharge pipe and re-install as shown on typical installation (Figure 3). **CAUTION:** For best performance of check valves when handling solids, install in a horizontal position or at an angle of not more than 45°. Do not install check valve in a vertical position, as solids may settle in valve and prevent opening on start-up. Remove the cord from the vent hole and install the vent pipe (see Figure 3 to complete typical installation).

To test the unit, plug the unit in and run water into the basin until the unit switches on. If the unit does not operate, refer to the troubleshooting information in the instructions for the pump.

Figure 1.
Pre-Packaged

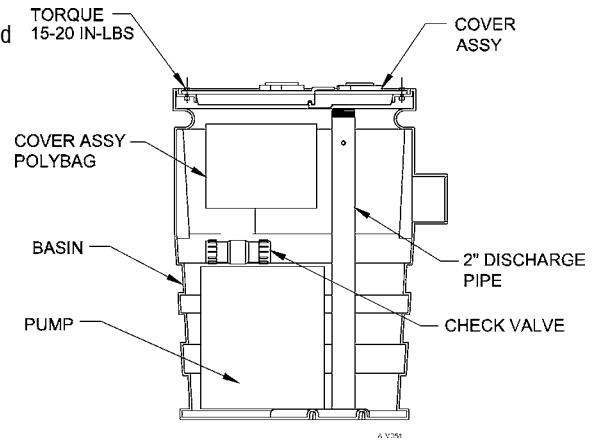

Figure 2.
Pre-Assembled

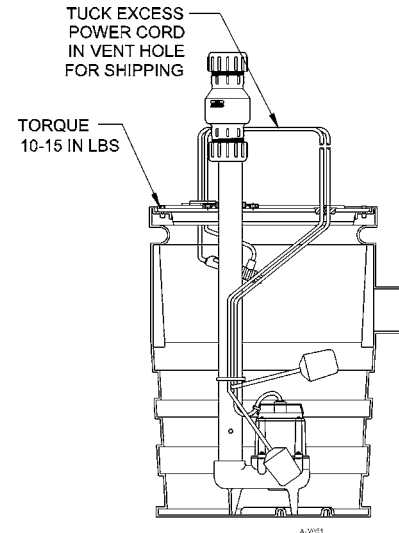
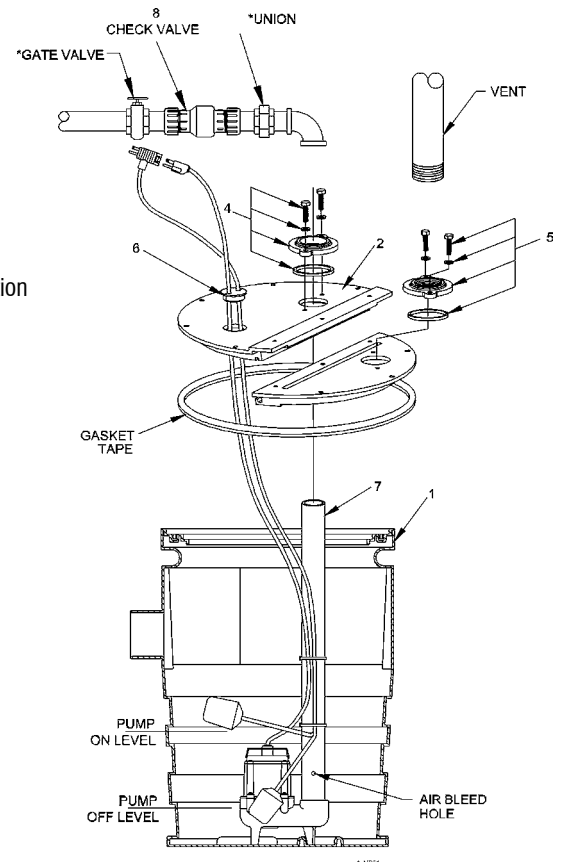

Figure 3.
Typical Installation



REPLACEMENT PARTS LIST			
ITEM	PART NO.	DESCRIPTION	QTY.
1	113096	BASIN, 20" x 30"	1
2	113184	COVER ASSEMBLY, 2" DISCHARGE	1
2	113185	COVER ASSEMBLY, 3" DISCHARGE	1
*	113171	COVER ASSEMBLY HARDWARE KIT	1
4	113214	FLANGE, 2" DISCHARGE PIPE	1
4	113216	FLANGE, 3" DISCHARGE PIPE	1
5	113215	FLANGE, 2" VENT PIPE	1
6	N/A	GROMMET, 2-HOLE	1
7	113423	PIPE, DISCHARGE 2"	1
7	113424	PIPE, DISCHARGE 3"	1
8	940022	CHECK VALVE, 2"	1
8	940023	CHECK VALVE, 3" (only on 509112 & 509113)	1
8	940026	CHECK VALVE/BALL VALVE, 2" (only on 509106 & 509107)	1