

Job Name/Location:

Tag #:

Date:

For:	File	Resubmit
	Approval	Other_____

PO No.:

Architect: _____ GC: _____

Engr: _____ Mech: _____

Rep: _____
(Company) (Project Manager)

PREMTC00U Simple Remote Controller

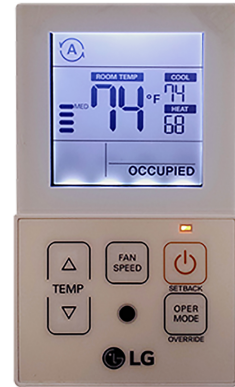

Unit Data:

Maximum No. of Indoor Units (Group Control)	16
Temperature Value*	Fahrenheit (1° Increments) / Celsius
Dimensions	4-3/4" L x 2-3/4" W x 5/8" H
Weight	0.18 lbs.

*Temperature Value depends on equipment.

Operating Range:

Cooling (°F DB)	64 ~ 86
Heating (°F WB)	60 ~ 86

Communications Cabling Specifications (V-Net):

Type	Field Supplied
Length**	164 feet
Size	22-3 AWG, twisted, stranded, unshielded

**Communication cable can be extended to a maximum of 164 feet between controller and indoor unit by using field supplied cable or the Wired Remote Group Control Cable Assembly (PZCWRCG3) or Wired Remote Extension Cable (PZWRC1), maximum of 4.

Standard Features:

- Auto Operation (Dual Setpoint)
- Unit Operation – On / Off
- Mode Selection – Cool / Heat / Dry / Fan / Auto
- Fan Speed Selection
- Air Flow Direction (available with indoor units equipped for this feature)
- Static Pressure Setting
- Child Lock
- LED Indicator for unit operating status
- Master / Slave Setting for Multiple Controller Installation
- Room Temperature Sensing Location (Zone Controller, Indoor Unit, Two-Thermistor)
- Discharge Vanes – Auto Swing / Fixed (available with indoor units equipped for this feature)
- Manual Central Control Addressing

Optional Accessories:

- 33-foot Extension Cable Assembly (PZCWRC1)
- Group Control Cable Kit (PZCWRCG3)

Notes:

1. Must follow installation instructions in the applicable LG installation manual.
2. Available functions / features may differ based on the connected system.

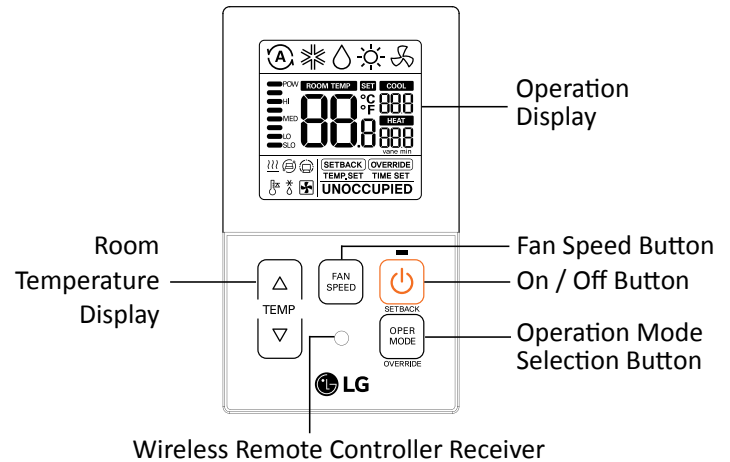

Job Name/Location:

Tag No:

Date:

For:	File	Resubmit
	Approval	Other

PO No.:

Architect: _____ GC: _____

Engr: _____ Mech: _____

Rep: _____
(Company) (Project Manager)

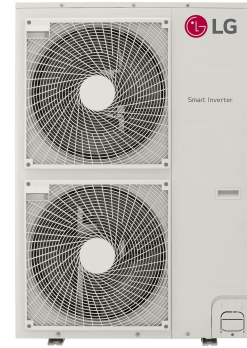

KUMXB541A

R32 Multi F Max Outdoor Unit

Outdoor Unit (ODU) - KUMXB541A

Performance:

Cooling Capacity (Min.-Rated-Max., Btu/h)	10,800-50,500-63,200
Heating Capacity (Min.-Rated-Max., Btu/h)	12,420-58,000-64,000
Max. Heating Capacity at 17°F (Btu/h)	48,000
Max. Heating Capacity at 5°F (Btu/h)	40,500
Max. Heating Capacity at -4°F (Btu/h)	35,200
Cooling COP @95°F (Rated)	3.69
Heating COP @47°F (Rated)	3.35

Cooling Nominal Test Conditions:
Indoor: 80°F DB / 67°F WB
Outdoor: 95°F DB / 75°F WB

Heating Nominal Test Conditions:
Indoor: 70°F DB / 60°F WB
Outdoor: 47°F DB / 43°F WB

Electrical:

Power Supply (V/Hz/Ø) ^{1,2}	208-230V, 60, 1
MOP (A)	40
MCA (A)	33.3
Cooling Rated Amps (A)	24.3
Heating Rated Amps (A)	24.3
Compressor (A)	23
Fan Motor (A)	0.65 x 2
Locked Rotor Amps (A)	22

MOP - Maximum Overcurrent Protection

MCA - Minimum Circuit Ampacity

Piping:

Refrigerant Charge (lbs.)	7.5
Liquid Line Connection (in., O.D.)	Ø3/8 x 1
Vapor Line Connection (in., O.D.)	Ø3/4 x 1
Maximum Total Piping ³ (ft.)	475.7
Min. / Max. ODU to IDU Piping ⁴ (ft.)	32.8 / 229.6
Piping Length ⁵ (no add'l refrigerant, ft.)	180.4
Additional Refrigerant Charge Main Pipe (oz. / ft.)	0.54
Additional Refrigerant Charge Branch Pipe (oz. / ft.)	0.22
Maximum Elevation between ODU and IDU (ft.)	98.4
Maximum Elevation between IDU and IDU (ft.)	49.2

ODU = Outdoor Unit

IDU = Indoor Unit

Features:

- Scroll (variable speed) compressor
- Auto operation / Auto restart
- Integrated central control connection
- Self diagnosis
- Defrost / Deicing
- Restart delay (three [3] minutes)
- Soft start
- Low ambient cooling down to 14°F (-4°F with Wind Baffle Kit)

Required Accessories:⁶

- 2-Port BD Unit - PMBD3620ZR
- 3-Port BD Unit - PMBD3630ZR
- 4-Port BD Units - PMBD3640ZR / PMBD3641ZR

Optional Accessories:

- Power Distribution Indicator (PDI) Premium - PQNUD1S41
- Mobile LGMV for Android® Smartphones / Tablets or for iOS® Tablets - PLGMMVW100
- LG Monitoring View (LGMV) for Computers - PRCTILO
- Drain Pan Heater - PQSH1200
- Low Ambient Wind Baffle Kit - ZLABGP04A x 2

(Android is a registered trademark of Google LLC. iOS is a registered trademark of Cisco Systems, Inc.)

Controller Options:

- MultiSITE Communication Mgr.
 - AC Smart 5
 - ACP 5
 - ACP 5 BACnet® Gateway
 - LonWorks® Gateway
- BACnet® is a registered trademark of ASHRAE. LonWorks is a registered trademark of Echelon Corp.

For a complete list of available accessories, contact your LG representative.

For continual product development, LG reserves the right to change specifications without notice.

© LG Electronics U.S.A., Inc., Englewood Cliffs, NJ. All rights reserved. "LG Life's Good" is a registered trademark of LG Corp. /www.lghvac.com

Operating Range:

Cooling (°F DB)	14 to 118
Heating (°F WB)	-4 to +64

Unit Data:

Refrigerant Type	R32
Refrigerant Control	EEV
Sound Pressure (Cool / Heat) ±1 dB(A) ⁷	53 / 55
Net / Shipping Weight (lbs.)	194 / 218.3
Power Wiring: ODU→BDU, BDU→IDU (No. x AWG) ²	3 x 14, 3 x 14
Comm. Wiring: ODU→BDU, BDU→IDU (No. x AWG) ²	2 x 18, 2 x 18
Heat Exchanger Coating	Gold Fin™
Minimum No. of Indoor Units	2
Maximum No. of Indoor Units	8

Compressor:

Type	Scroll
Quantity	1
Oil / Type	PVE

Fan:

Type	Propeller
Quantity	2
Motor / Drive	Brushless Digitally Controlled/Direct
Max. Airflow Rate (CFM)	2,295 x 2

Notes:

1. Acceptable operating voltage: 187V - 253V.
2. All power supply wiring to the outdoor unit is field supplied, solid or stranded. The power wiring and the communication wiring from the outdoor unit to the branch distribution unit, and from the branch distribution unit to the indoor unit is field supplied and must be stranded, shielded or unshielded (if shielded, it must be grounded to the chassis of the outdoor unit only). All wiring must comply with applicable local and national codes.
 - a. Power Supply Wiring to Outdoor Unit (No. x AWG): 3 x 8 for 48k, 54k, and 60k.
 - b. Power Wiring and Communication Wiring from ODU to BDU (No. x AWG) 3 x 14 / 2 x 18.
 - c. Power Wiring and Communication Wiring from BDU to IDU (No. x AWG) 3 x 14 / 2 x 18.
3. Piping lengths are equivalent.
4. 180.4 ft. of Main Piping + 49.2 ft. of Branch Piping.
5. 49.2 ft. of Main Piping + 131.2 of Branch Piping.
6. At least one branch distribution (BD) unit is required for system operation; a maximum of two can be installed per outdoor unit with the use of a Y-branch accessory (ARBLN03321).
7. Sound pressure levels are tested in an anechoic chamber under ISO Standard 3745.
8. See the Engineering Manual Capacity Tables for ODU sensible and latent capacities.
9. See the Engineering Manual Combination Tables for allocation of ODU rated capacity to each connected IDU when all are calling for full capacity. Allocation percentages should be applied to ODU capacity at design conditions.
10. Capacity is rated 0 ft. above sea level, with a 0 ft. level difference between ODU and IDUs, and the following refrigerant pipe lengths: KUMXB481 / 541 / 601A: 16.4 ft. Main + (16.4 ft. Branch x 8) = 147.6 ft. All capacities are net with a combination ratio between 95 - 105%.
11. Must follow installation instructions in the applicable LG installation manual.
12. See the Engineering Manual Capacity Tables for ODU capacity at design conditions.



Proper sizing and installation of equipment is critical to achieve optimal performance. Split system air conditioners and heat pumps (excluding ductless systems) must be matched with appropriate coil components to meet ENERGY STAR® criteria. Ask your contractor for details or visit www.energystar.gov. (ENERGY STAR and the ENERGY STAR mark are registered trademarks owned by the U.S. Environmental Protection Agency.)

KUMXB541A
R32 Multi F Max Outdoor Unit
 Outdoor Unit (ODU) - KUMXB541A



Tag No.: _____

Date: _____

PO No.: _____

Example: Outdoor unit with seven (7) indoor units, and two (2) branch distribution units connected. ODU:
 Outdoor Unit.
 IDU: Indoor Unit.
 BD: Branch Distribution Unit(s).
 A: Main Pipe.
 B: Branch Pipe (Branch Distribution Unit[s] to Indoor Unit[s]).



Multi F MAX Outdoor Unit Refrigerant Piping System Limitations.

Pipe Length (ELF = Equivalent Length of pipe in Feet)	Total piping length ($\Sigma A + \Sigma B$)	≤475.7 feet	
	Main pipe (Outdoor Unit to Branch Distribution Units: A)	Minimum for Each (A) Piping Segment	16.4 feet
		Maximum (ΣA)	≤180.4 feet
	Total branch piping length (ΣB)	≤295.3 feet	
	Branch pipe (Branch Distribution Units to Indoor Units: B)	Minimum	16.4 feet
Maximum		≤49.2 feet	
Elevation Differential (All Elevation Limitations are Measured in Actual Feet)	If outdoor unit is above or below indoor unit (h1)	≤98.4 feet	
	Between the farthest two indoor units (h2)	≤49.2 feet	
	Between branch distribution unit and farthest connected indoor unit(s) (h3)	≤32.8 feet	
	Between branch distribution units (h4)	≤49.2 feet	

Installing the Unit

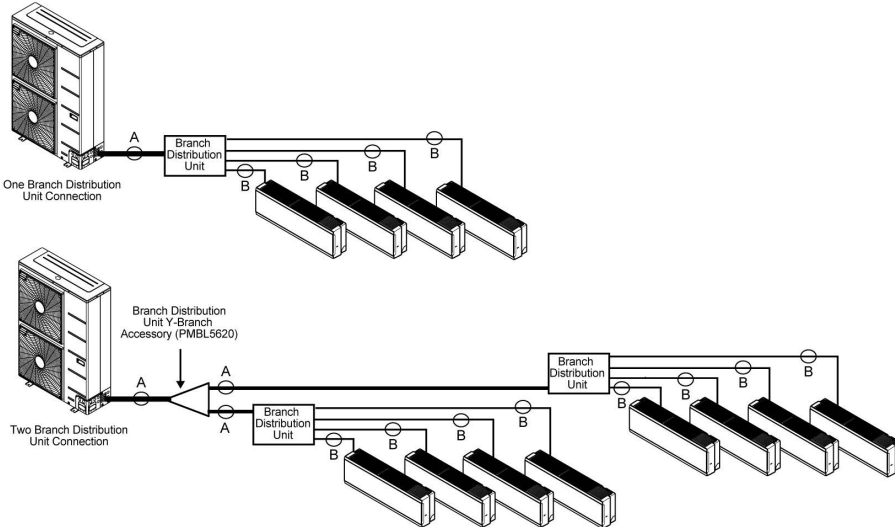

Multi F MAX Piping Sizes.

Piping	Main Pipe A (inch)	Branch Pipe B
Liquid	ø3/8	Depends on the size of the indoor unit piping.
Vapor	ø3/4	

Job Name/Location:

Tag #:

Date:

For:	File	Resubmit
	Approval	Other_____

PO No.:

Architect: _____ GC: _____

Engr: _____ Mech: _____

Rep: _____

(Company)

(Project Manager)



KNMKB091A
Multi F R32 Low Static Ducted Indoor Unit
9,000 Btu/h

Performance:

Nominal Cooling Capacity (Btu/h)	9,000
Nominal Heating Capacity (Btu/h)	10,400

Cooling Nominal Test Conditions:

Indoor: 80°F DB / 67°F WB
Outdoor: 95°F DB / 75°F WB

Heating Nominal Test Conditions:

Indoor: 70°F DB / 60°F WB
Outdoor: 47°F DB / 43°F WB

Electrical:

Power Supply (V/Hz/Ø) ^{1,2}	208-230/60/1
Rated Amps (A)	0.4

Piping:

Installed Liquid Pipe (in., O.D.)	ø1/4
Installed Vapor Pipe (in., O.D.)	ø3/8
Liquid Connection (in., O.D.)	ø1/4
Vapor Connection (in., O.D.)	ø3/8
Drain (in., O.D. / I.D.)	1-1/4 / 1
Temperature Sensor	Thermistor

Controls Features:

- Inverter (variable speed fan)
- Long-life washable prefilter
- Hot start
- Self diagnosis
- Soft dry operation
- Auto operation
- Auto restart
- Sleep mode
- Timer (on/off/weekly)
- Drain pump
- ESP control
- R32 leak detection sensor

Optional Accessories:

- Single-Port Shutoff Valve - PRHPZ010A
- Auxiliary Heater Kit - PRARH1

Controller Options:

- MultiSITE™ CRC* Controllers
- Simple Remote Controllers
- Standard III Remote Controllers
- Deluxe Remote Controller
- Remote Temperature Button Sensor
- Dry Contacts
- Wi-Fi Module - PWFMD200

Entering Mixed Air:

Cooling (°F WB)	57 ~ 77
Heating (°F DB)	59 ~ 81

Unit Data:

Refrigerant Type	R32
Refrigerant Control	EEV
Sound Pressure (H/M/L) dB(A) ³	30 / 26 / 23
Primary Filter	Washable Pre-filter
Net Weight (lbs.)	35.1
Shipping Weight (lbs.)	43.4

Fan:

Type	Sirocco
Quantity	1
Motor/Drive	Brushless Digitally Controlled/Direct
Air Flow H/M/L (CFM)	318 / 247 / 194
External Static Pressure ^{4,5} (in wg)	0.10
Minimum External Static Pressure	0.00
Maximum External Static Pressure	0.20
Dehumidification (pts./hr.)	1.37

Notes:

1. Acceptable operating voltage: 187V-253V.
2. The power wiring and the communication wiring from the outdoor unit to the indoor unit, or from the branch distribution unit to the indoor unit is field supplied and must be stranded, shielded or unshielded (if shielded, it must be grounded to the chassis of the outdoor unit only). All wiring must comply with applicable local and national codes.
 - a. Power wiring and communication wiring from outdoor unit to indoor unit (No. x AWG) 3 x 14 / 2 x 18.
 - b. Power wiring and communication wiring from branch distribution unit to indoor unit (No. x AWG) 3 x 14 / 2 x 18.
3. Sound Pressure levels are tested in an anechoic chamber under ISO Standard 3745.
4. Adjust fan speed to correct for static pressure increases when using field-supplied air filter.
5. At factory fan speed setting.
6. See Engineering Manual for sensible and latent capacities.
7. The indoor unit comes with a dry helium charge.
8. Corresponding refrigerant piping length is in accordance with standard length of each outdoor unit and the level difference is 0 ft. All capacities are net with a combination ratio between 95 - 105%.
9. Must follow installation instructions in the applicable LG installation manual.



Job Name/Location: _____

KNMKB091A
Multi F R32 Low Static Ducted Indoor Unit
 9,000 Btu/h



Tag No.: _____

Date: _____

PO No.: _____

(unit: inch)

Model Number	A	B	C	D
KNMKB091A	30-15/32	27-9/16	28-27/32	25-31/32
KNMKB121A	38-11/32	35-7/16	36-23/32	33-27/32
KNMKB181A				

(unit: inch)

Number	Name	Description
1	Liquid pipe connection	
2	Gas pipe connection	
3	Drain pipe connection	
4	Power supply connection	
5	Air discharge	
6	Air suction	

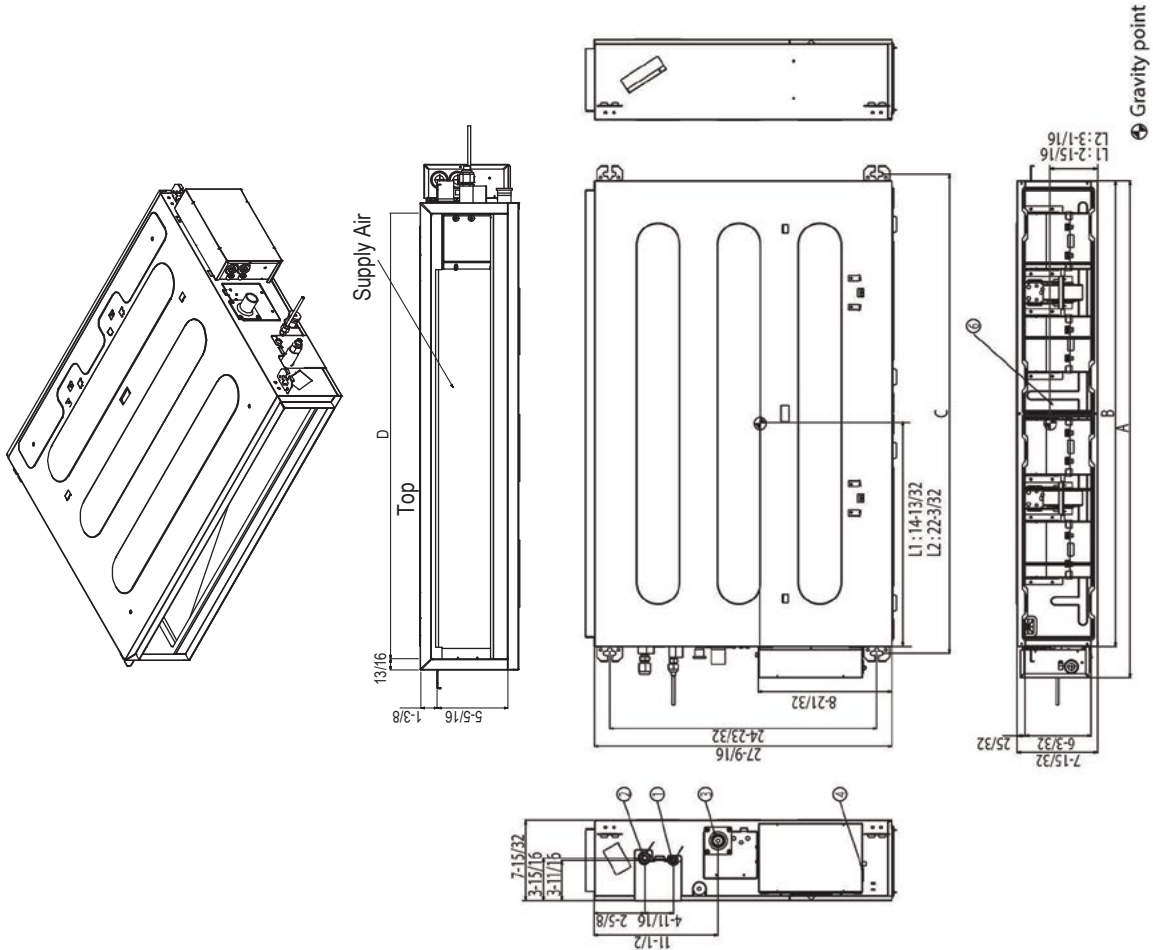

Job Name/Location:

Tag #:

Date:

For:	File	Resubmit
	Approval	Other_____

PO No.:

Architect: _____ GC: _____

Engr: _____ Mech: _____

Rep: _____

(Company)

(Project Manager)



KNMKB121A
Multi F R32 Low Static Ducted Indoor Unit
12,000 Btu/h

Performance:

Nominal Cooling Capacity (Btu/h)	12,000
Nominal Heating Capacity (Btu/h)	13,800

Cooling Nominal Test Conditions:

Indoor: 80°F DB / 67°F WB
Outdoor: 95°F DB / 75°F WB

Heating Nominal Test Conditions:

Indoor: 70°F DB / 60°F WB
Outdoor: 47°F DB / 43°F WB

Electrical:

Power Supply (V/Hz/Ø) ^{1,2}	208-230/60/1
Rated Amps (A)	0.8

Piping:

Installed Liquid Pipe (in., O.D.)	ø1/4
Installed Vapor Pipe (in., O.D.)	ø3/8
Liquid Connection (in., O.D.)	ø1/4
Vapor Connection (in., O.D.)	ø3/8
Drain (in., O.D. / I.D.)	1-1/4 / 1
Temperature Sensor	Thermistor

Controls Features:

- Inverter (variable speed fan)
- Long-life washable prefilter
- Hot start
- Self diagnosis
- Soft dry operation
- Auto operation
- Auto restart
- Sleep mode
- Timer (on/off/weekly)
- Drain pump
- ESP control
- R32 leak detection sensor

Optional Accessories:

- Single-Port Shutoff Valve - PRHPZ010A
- Auxiliary Heater Kit - PRARH1

Controller Options:

- MultiSITE™ CRC* Controllers
- Simple Remote Controllers
- Standard III Remote Controllers
- Deluxe Remote Controller
- Remote Temperature Button Sensor
- Dry Contacts
- Wi-Fi Module - PWFMD200

Entering Mixed Air:

Cooling (°F WB)	57 ~ 77
Heating (°F DB)	59 ~ 81

Unit Data:

Refrigerant Type	R32
Refrigerant Control	EEV
Sound Pressure (H/M/L) dB(A) ³	31 / 28 / 27
Primary Filter	Washable Pre-filter
Net Weight (lbs.)	45.4
Shipping Weight (lbs.)	55.2

Fan:

Type	Sirocco
Quantity	2
Motor/Drive	Brushless Digitally Controlled/Direct
Air Flow H/M/L (CFM)	353 / 300 / 247
External Static Pressure ^{4,5} (in wg)	0.10
Minimum External Static Pressure	0.00
Maximum External Static Pressure	0.20
Dehumidification (pts./hr.)	1.86

Notes:

1. Acceptable operating voltage: 187V-253V.
2. The power wiring and the communication wiring from the outdoor unit to the indoor unit, or from the branch distribution unit to the indoor unit is field supplied and must be stranded, shielded or unshielded (if shielded, it must be grounded to the chassis of the outdoor unit only). All wiring must comply with applicable local and national codes.
 - a. Power wiring and communication wiring from outdoor unit to indoor unit (No. x AWG) 3 x 14 / 2 x 18.
 - b. Power wiring and communication wiring from branch distribution unit to indoor unit (No. x AWG) 3 x 14 / 2 x 18.
3. Sound Pressure levels are tested in an anechoic chamber under ISO Standard 3745.
4. Adjust fan speed to correct for static pressure increases when using field-supplied air filter.
5. At factory fan speed setting.
6. See Engineering Manual for sensible and latent capacities.
7. The indoor unit comes with a dry helium charge.
8. Corresponding refrigerant piping length is in accordance with standard length of each outdoor unit and the level difference is 0 ft. All capacities are net with a combination ratio between 95 - 105%.
9. Must follow installation instructions in the applicable LG installation manual.



Job Name/Location: _____

KNMKB121A
 Multi F R32 Low Static Ducted Indoor Unit
 12,000 Btu/h



Tag No.: _____

Date: _____

PO No.: _____

(unit: inch)

Model Number	A	B	C	D
KNMKB091A	30-15/32	27-9/16	28-27/32	25-31/32
KNMKB121A	38-11/32	35-7/16	36-23/32	33-27/32
KNMKB181A				

(unit: inch)

Number	Name	Description
1	Liquid pipe connection	
2	Gas pipe connection	
3	Drain pipe connection	
4	Power supply connection	
5	Air discharge	
6	Air suction	

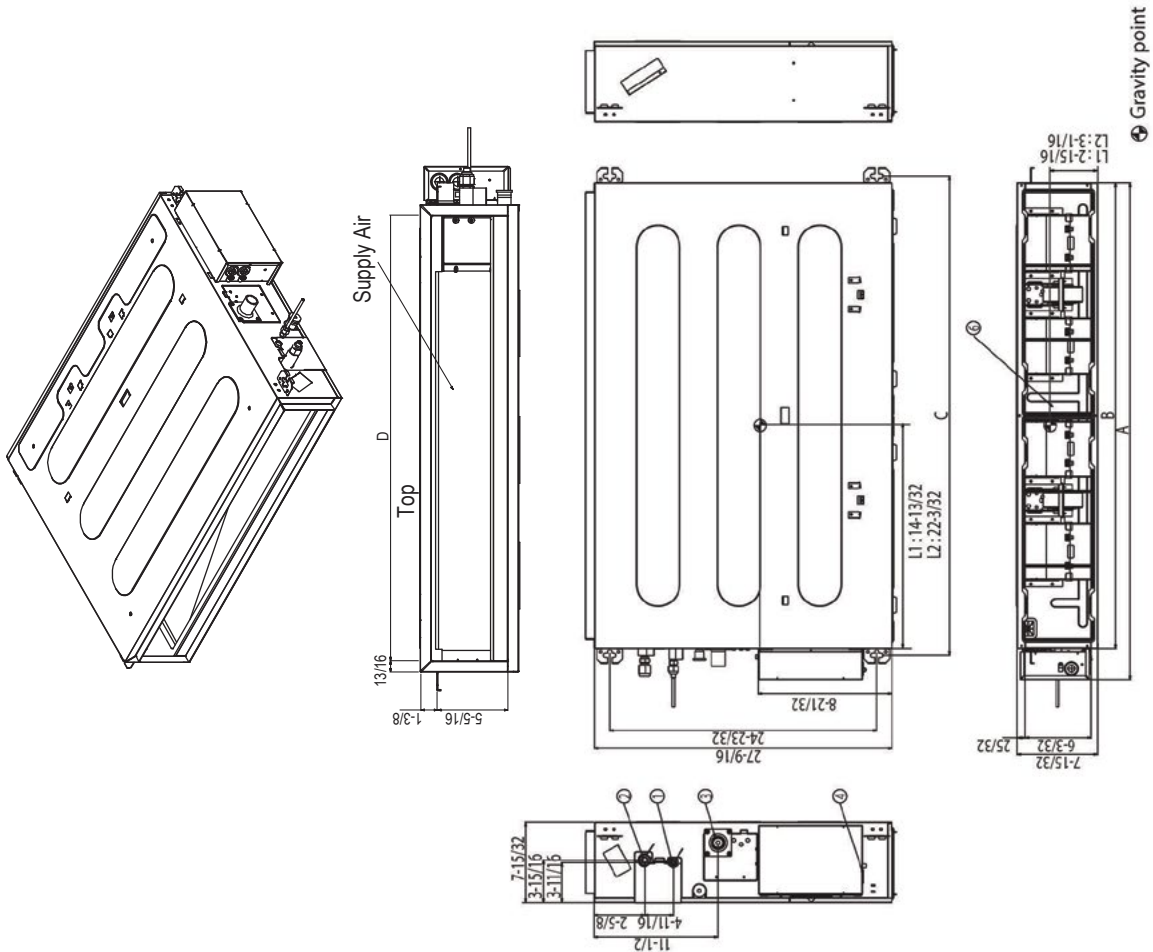

Job Name/Location:

Tag #:

Date:

For:	File	Resubmit
	Approval	Other_____

PO No.:

Architect: _____ GC: _____

Engr: _____ Mech: _____

Rep: _____

(Company)

(Project Manager)



KNMKB181A
Multi F R32 Low Static Ducted Indoor Unit
18,000 Btu/h

Performance:

Nominal Cooling Capacity (Btu/h)	18,000
Nominal Heating Capacity (Btu/h)	20,800

Cooling Nominal Test Conditions:

Indoor: 80°F DB / 67°F WB
Outdoor: 95°F DB / 75°F WB

Heating Nominal Test Conditions:

Indoor: 70°F DB / 60°F WB
Outdoor: 47°F DB / 43°F WB

Electrical:

Power Supply (V/Hz/Ø) ^{1,2}	208-230/60/1
Rated Amps (A)	0.8

Piping:

Installed Liquid Pipe (in., O.D.)	ø1/4
Installed Vapor Pipe (in., O.D.)	ø1/2
Liquid Connection (in., O.D.)	ø1/4
Vapor Connection (in., O.D.)	ø1/2
Drain (in., O.D. / I.D.)	1-1/4 / 1
Temperature Sensor	Thermistor

Controls Features:

- Inverter (variable speed fan)
- Long-life washable prefilter
- Hot start
- Self diagnosis
- Soft dry operation
- Auto operation
- Auto restart
- Sleep mode
- Timer (on/off/weekly)
- Drain pump
- ESP control
- R32 leak detection sensor

Optional Accessories:

- Single-Port Shutoff Valve - PRHPZ010A
- Auxiliary Heater Kit - PRARH1

Controller Options:

- MultiSITE™ CRC* Controllers
- Simple Remote Controllers
- Standard III Remote Controllers
- Deluxe Remote Controller
- Remote Temperature Button Sensor
- Dry Contacts
- Wi-Fi Module - PWFMD200

Entering Mixed Air:

Cooling (°F WB)	57 ~ 77
Heating (°F DB)	59 ~ 81

Unit Data:

Refrigerant Type	R32
Refrigerant Control	EEV
Sound Pressure (H/M/L) dB(A) ³	36 / 34 / 31
Primary Filter	Washable Pre-filter
Net Weight (lbs.)	45.4
Shipping Weight (lbs.)	55.2

Fan:

Type	Sirocco
Quantity	2
Motor/Drive	Brushless Digitally Controlled/Direct
Air Flow H/M/L (CFM)	530 / 441 / 353
External Static Pressure ^{4,5} (in wg)	0.10
Minimum External Static Pressure	0.00
Maximum External Static Pressure	0.20
Dehumidification (pts./hr.)	2.01

Notes:

1. Acceptable operating voltage: 187V-253V.
2. The power wiring and the communication wiring from the outdoor unit to the indoor unit, or from the branch distribution unit to the indoor unit is field supplied and must be stranded, shielded or unshielded (if shielded, it must be grounded to the chassis of the outdoor unit only). All wiring must comply with applicable local and national codes.
 - a. Power wiring and communication wiring from outdoor unit to indoor unit (No. x AWG) 3 x 14 / 2 x 18.
 - b. Power wiring and communication wiring from branch distribution unit to indoor unit (No. x AWG) 3 x 14 / 2 x 18.
3. Sound Pressure levels are tested in an anechoic chamber under ISO Standard 3745.
4. Adjust fan speed to correct for static pressure increases when using field-supplied air filter.
5. At factory fan speed setting.
6. See Engineering Manual for sensible and latent capacities.
7. The indoor unit comes with a dry helium charge.
8. Corresponding refrigerant piping length is in accordance with standard length of each outdoor unit and the level difference is 0 ft. All capacities are net with a combination ratio between 95 - 105%.
9. Must follow installation instructions in the applicable LG installation manual.



Job Name/Location: _____

KNMKB181A
 Multi F R32 Low Static Ducted Indoor Unit
 18,000 Btu/h



Tag No.: _____

Date: _____

PO No.: _____

(unit: inch)

Model Number	A	B	C	D
KNMKB091A	30-15/32	27-9/16	28-27/32	25-31/32
KNMKB121A	38-11/32	35-7/16	36-23/32	33-27/32
KNMKB181A				

(unit: inch)

Number	Name	Description
1	Liquid pipe connection	
2	Gas pipe connection	
3	Drain pipe connection	
4	Power supply connection	
5	Air discharge	
6	Air suction	

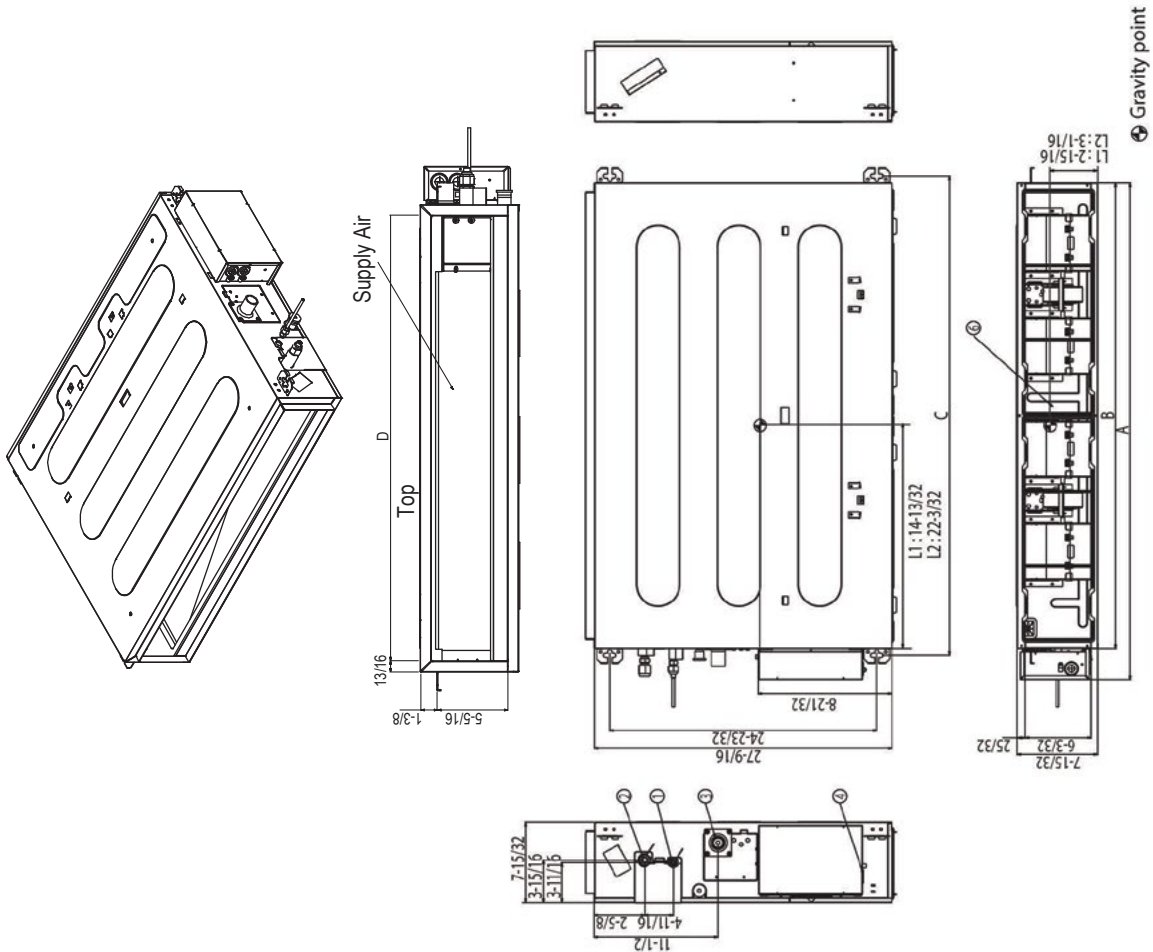

Job Name/Location: _____

Tag No: _____

Date: _____

For:	File	Resubmit
	Approval	Other _____

PO No.: _____

Architect: _____ GC: _____

Engr: _____ Mech: _____

Rep: _____
(Company) (Project Manager)



PMBD3640ZR

Four-Port Branch Distribution Unit

For Multi F MAX and Multi F MAX with LGRED® Outdoor Units

Performance:

Max. Nominal Port Capacity (Btu/h) (each port)	24,000
Max. Nominal Unit Capacity (Btu/h) (sum of ports)	73,000
Connected Indoor Unit Capacity (Btu/h)	7,000 ~ 24,000
Power Input (W)	97

Electrical:

Power Supply (V/Hz/Ø) ¹	208-230/60/1
Rated Amps (A)	0.4

Piping:

Piping Connections to Outdoor Unit:

Liquid Line (in., O.D.)	Ø3/8 Braze
Vapor Line (in., O.D.)	Ø3/4 Braze

Piping Connections to Indoor Unit:

Liquid Line (in., O.D.)	Ø1/4 Flare x 4
Vapor Line (in., O.D.)	Ø3/8 Flare x 4

Features:

- Distributes refrigerant to indoor units
- Internal components are insulated
- Compact design

Operating Range:

Temperature Range (°F D.B.)	0 ~ 150
Maximum Humidity	80%

Unit Data:

Net Weight (lbs.)	19.4
Shipping Weight (lbs.)	22.9
Power Wiring: ODU→BDU, BDU→IDU (No x AWG) ²	3 x 14, 3 x 14
Comm. Wiring: ODU→BDU, BDU→IDU (No x AWG) ²	2 x 18, 2 x 18

Notes:

1. Acceptable operating voltage: 187V-253V.
2. The power wiring and the communication wiring from the outdoor unit to the branch distribution unit, and from the branch distribution unit to the indoor unit is field supplied and must be stranded, shielded or unshielded (if shielded, it must be grounded to the chassis of the outdoor unit only). All wiring must comply with applicable local and national codes.
 - a. Power Wiring and Communication Wiring from ODU to BDU (No. x AWG) 3 x 14 / 2 x 18.
 - b. Power Wiring and Communication Wiring from BDU to IDU (No. x AWG) 3 x 14 / 2 x 18.
3. Piping lengths:
 - Maximum height difference between branch distribution unit and indoor units - 32.8 feet.
 - Maximum height difference between branch distribution unit and branch distribution unit - 49.2 feet.
 - Maximum piping length between branch distribution unit and indoor units - 49.2 feet.
4. The branch distribution unit should be installed inside of a building.
5. Must follow installation instructions in the applicable LG installation manual.



PMBD3640ZR
Four-Port Branch Distribution Unit
 For Multi F MAX and Multi F MAX with LGRED® Outdoor Units



Tag No.: _____

Date: _____

PO No.: _____

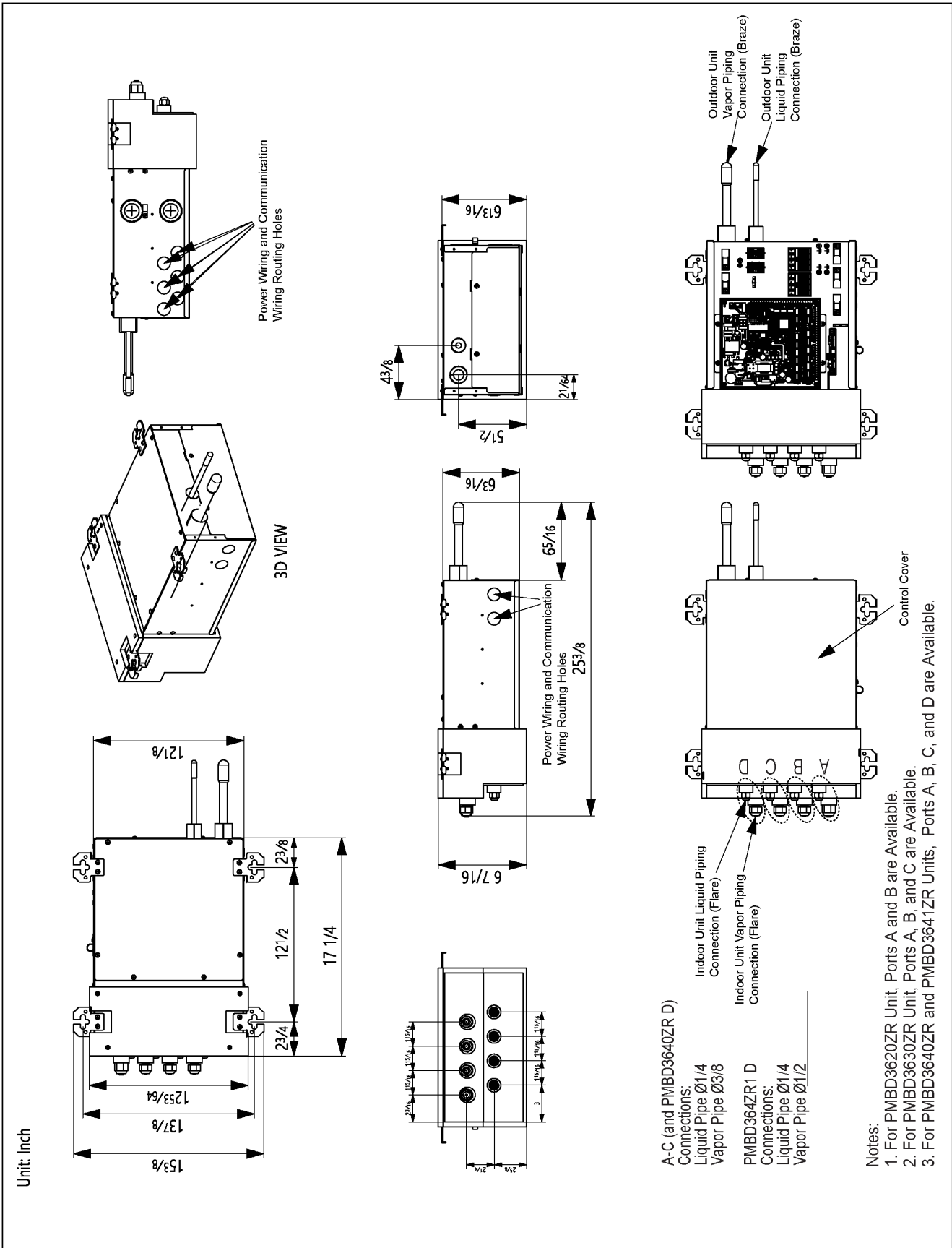

Unit: Inch

A-C (and PMBD3640ZR D)

Connections:

Liquid Pipe Ø1/4

Vapor Pipe Ø3/8

PMBD364ZR1 D

Connections:

Liquid Pipe Ø1/4

Vapor Pipe Ø1/2

Notes:

1. For PMBD3620ZR Unit, Ports A and B are Available.

2. For PMBD3630ZR Unit, Ports A, B, and C are Available.

3. For PMBD3640ZR and PMBD3641ZR Units, Ports A, B, C, and D are Available.