

Job Name/Location: \_\_\_\_\_

Tag No: \_\_\_\_\_

Date: \_\_\_\_\_

For:	File	Resubmit
	Approval	Other

PO No.: \_\_\_\_\_

Architect: \_\_\_\_\_ GC: \_\_\_\_\_

Engr: \_\_\_\_\_ Mech: \_\_\_\_\_

Rep: \_\_\_\_\_  
(Company) (Project Manager)

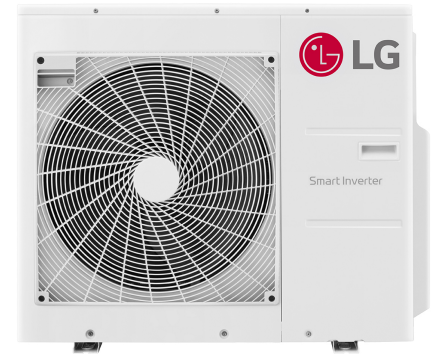

**KUMXB301A**  
**R32 Multi F Outdoor Unit**  
 Outdoor Unit (ODU) - KUMXB301A

**Performance:**

Cooling Capacity (Min.-Rated-Max., Btu/h)	8,400~30,000~36,000
Heating Capacity (Min.-Rated-Max., Btu/h)	10,080~32,000~38,400
Max. Heating Capacity at 17°F (Btu/h)	27,200
Max. Heating Capacity at 5°F (Btu/h)	24,000
Max. Heating Capacity at -4°F (Btu/h)	20,400
Cooling COP @95°F (Rated)	3.81
Heating COP @47°F (Rated)	4.01

Cooling Nominal Test Conditions:  
 Indoor: 80°F DB / 67°F WB  
 Outdoor: 95°F DB / 75°F WB

Heating Nominal Test Conditions:  
 Indoor: 70°F DB / 60°F WB  
 Outdoor: 47°F DB / 43°F WB

**Electrical:**

Power Supply (V/Hz/Ø) <sup>1,2</sup>	208-230V, 60, 1
MOP (A)	25
MCA (A)	19.0
Cooling Rated Amps (A)	14.15
Heating Rated Amps (A)	14.15
Compressor (A)	13.5
Fan Motor (A)	0.65
Locked Rotor Amps (A)	19.0

MOP - Maximum Overcurrent Protection

MCA - Minimum Circuit Ampacity

**Piping:**

Refrigerant Charge (lbs.)	4.85
Liquid Line Connection (in., O.D.)	1/4 x 4
Vapor Line Connection (in., O.D.)	3/8 x 4
Maximum Total Piping <sup>3</sup> (ft.)	246.1
Min. / Max. ODU to IDU Piping (ft.)	9.8 / 82.0
Piping Length (no add'l refrigerant, ft.)	123
Additional Refrigerant Charge (oz. / ft.)	0.22
Maximum Elevation between ODU and IDU (ft.)	49.2
Maximum Elevation between IDU and IDU (ft.)	24.6

ODU = Outdoor Unit

IDU = Indoor Unit

**Features:**

- Auto operation / Auto restart
- Inverter (variable speed compressor)
- Integrated central control connection
- Defrost / Deicing
- Restart delay (three [3] minutes)
- Self diagnosis
- Soft start
- Low ambient cooling down to 14°F (-4°F with Wind Baffle Kit)

**Optional Accessories:**

- Power Distribution Indicator (PDI) Premium - PQNUD1S41
- Mobile LGMV for Android® Smartphones / Tablets or for iOS® Tablets - PLGMVW100  
(Android is a registered trademark of Google LLC. iOS is a registered trademark of Cisco Systems, Inc.)
- LG Monitoring View (LGMV) for Computers - PRCTILO
- Drain Pan Heater - PQSH1200
- Low Ambient Wind Baffle Kit - ZLABGP04A

**Controller Options:**

- MultiSITE Communication Mgr.
- AC Smart 5
- ACP 5
- ACP 5 BACnet® Gateway
- LonWorks® Gateway  
BACnet® is a registered trademark of ASHRAE. LonWorks is a registered trademark of Echelon Corp.

For a complete list of available accessories, contact your LG representative.

For continual product development, LG reserves the right to change specifications without notice.

© LG Electronics U.S.A., Inc., Englewood Cliffs, NJ. All rights reserved. "LG Life's Good" is a registered trademark of LG Corp. /www.lghvac.com

**Operating Range:**

Cooling (°F DB)	14 to 118
Heating (°F WB)	-4 to +64

**Unit Data:**

Refrigerant Type	R32
Refrigerant Control	EEV
Sound Pressure (Cool / Heat) ±1 dB(A) <sup>4</sup>	51 / 54
Net / Shipping Weight (lbs.)	140 / 156.5
Power Wiring from ODU to IDU (No x AWG) <sup>2</sup>	3 x 14
Communication Wiring from ODU to IDU (No x AWG) <sup>2</sup>	2 x 18
Heat Exchanger Coating	Gold Fin™
Minimum No. of Indoor Units	2
Maximum No. of Indoor Units	4

**Compressor:**

Type	Twin Rotary
Quantity	1
Oil / Type	FW68D

**Fan:**

Type	Axial
Quantity	1
Motor / Drive	Brushless Digitally Controlled/Direct
Max. Airflow Rate (CFM)	2,295

**Notes:**

1. Acceptable operating voltage: 187V - 253V.
2. All power supply wiring to the outdoor unit is field supplied, solid or stranded. The power wiring and the communication wiring from the outdoor unit to the indoor unit is field supplied and must be stranded, shielded or unshielded (if shielded, it must be grounded to the chassis of the outdoor unit only). All wiring must comply with applicable local and national codes.
  - a. Power Supply Wiring to Outdoor Unit (No. x AWG): 3 x 14 for 18k and 24k; 3 x 12 for 30k and 36k.
  - b. Power Wiring and Communication Wiring from Outdoor Unit to Indoor Unit (No. x AWG) 3 x 14 / 2 x 18.
3. Piping lengths are equivalent.
4. Sound pressure levels are tested in an anechoic chamber under ISO Standard 3745.
5. This data is rated 0 ft. above sea level, with 0 ft. level difference between outdoor and indoor units, and the following refrigerant pipe lengths:
  - KUMXB181A: 16.4 ft. x 2 = 32.8 ft.
  - KUMXB241A: 16.4 ft. x 3 = 49.2 ft.
  - KUMXB301A: 16.4 ft. x 4 = 65.6 ft.
  - KUMXB361A: 16.4 ft. x 4 = 65.6 ft.
6. All capacities are net with a combination ratio between 95 - 105%.
7. Must follow installation instructions in the applicable LG installation manual.
8. Refer to the Combination Data Manual for combination capacity tables.
9. See the Performance Data Manual for sensible and latent capacities.



Proper sizing and installation of equipment is critical to achieve optimal performance. Split system air conditioners and heat pumps (excluding ductless systems) must be matched with appropriate coil components to meet ENERGY STAR® criteria. Ask your contractor for details or visit [www.energystar.gov](http://www.energystar.gov). (ENERGY STAR and the ENERGY STAR mark are registered trademarks owned by the U.S. Environmental Protection Agency.)



Job Name/Location:

Tag No.:

Date:

For:	File	Resubmit
	Approval	Other

PO No.:

Architect: GC:

Engr: Mech:

Rep: (Company) (Project Manager)



**KNUAB091A**  
**R32 Multi F Wall Mounted High Efficiency Indoor Unit**  
 9,000 Btu/h



**Performance:**

Nominal Cooling Capacity (Btu/h)	9,000
Nominal Heating Capacity (Btu/h)	10,900

Cooling Nominal Test Conditions:  
 Indoor: 80°F DB / 67°F WB  
 Outdoor: 95°F DB / 75°F WB

Heating Nominal Test Conditions:  
 Indoor: 70°F DB / 60°F WB  
 Outdoor: 47°F DB / 43°F WB

**Electrical:**

Power Supply (V/Hz/Ø) <sup>1,2</sup>	208-230/60/1
Rated Current (A)	0.4

**Piping:**

Installed Liquid Pipe (in., O.D.)	Ø1/4
Installed Vapor Pipe (in., O.D.)	Ø3/8
Liquid Connection (in., O.D.)	Ø1/4
Vapor Connection (in., O.D.)	Ø3/8
Drain (in., O.D. / I.D.)	27/32, 5/8
Temperature Sensor	Thermistor

**Controls Features:**

- Left / right and up / down auto swing
- 24-Hour on/off timer
- Auto operation
- Auto restart
- Group control
- Inverter (variable speed fan)
- Jet cool / Jet heat
- 3M Micro Dust Filter
- Self-cleaning indoor coil
- Sleep mode
- R32 leak detection sensor
- Built-in Wi-Fi via Smart ThinQ app
- Compatible with applicable Single Zone Outdoor Units (see single zone literature for matching system details)

**Included Accessories:**

- Wireless Remote Controller — AKB76044208

**Optional Accessories:**

- Auxiliary Heater Kit - PRARS1
- Single-Port Shutoff Valve - PRHPZ010A

**Controller Options:**

- MultiSITE™ CRC\* Controllers
- Simple Remote Controllers
- Standard III Remote Controllers
- Deluxe Remote Controller
- Remote Temperature Button Sensor
- Dry Contacts

**Entering Mixed Air:**

Cooling (°F WB)	57 ~ 77
Heating (°F DB)	59 ~ 81

**Unit Data:**

Refrigerant Type	R32
Refrigerant Control	EEV
Sound Pressure (H/M/L) (±3 dB[A]) <sup>3</sup>	36 / 32 / 27
Primary Filter	Washable Pre-filter
Secondary Filter	3M Micro Dust
Net Weight (lbs.)	19.73
Shipping Weight (lbs.)	22.7

**Fan:**

Type	Cross Flow
Quantity	1
Motor/Drive	Brushless Digitally Controlled/Direct
Air Flow H/M/L (CFM)	268 / 218 / 169
Dehumidification (pts./hr.)	2.70

**Notes:**

1. Acceptable operating voltage: 187V-253V.
2. The power wiring and the communication wiring from the outdoor unit to the indoor unit, or from the branch distribution unit to the indoor unit is field supplied and must be stranded, shielded or unshielded (if shielded, it must be grounded to the chassis of the outdoor unit only). All wiring must comply with applicable local and national codes.
  - a. Power Wiring and Communication Wiring from Outdoor Unit to Indoor Unit (No. x AWG) 3 x 14 / 2 x 18.
  - b. Power Wiring and Communication Wiring from Branch Distribution Unit to Indoor Unit (No. x AWG) 3 x 14 / 2 x 18.
3. Sound Pressure levels are tested in an anechoic chamber under ISO Standard 3745.
4. See Engineering Manual for sensible and latent capacities.
5. The indoor unit comes with a dry helium charge.
6. Corresponding refrigerant piping length is in accordance with standard length of each outdoor unit and the level difference is 0 ft. All capacities are net with a combination ratio between 95 - 105%.
7. Must follow installation instructions in the applicable LG installation manual.



**KNUAB091A**  
**R32 Multi F Wall Mounted High Efficiency Indoor Unit**  
 9,000 Btu/h



Tag No.: \_\_\_\_\_

Date: \_\_\_\_\_

PO No.: \_\_\_\_\_

Unit : Inch (mm)

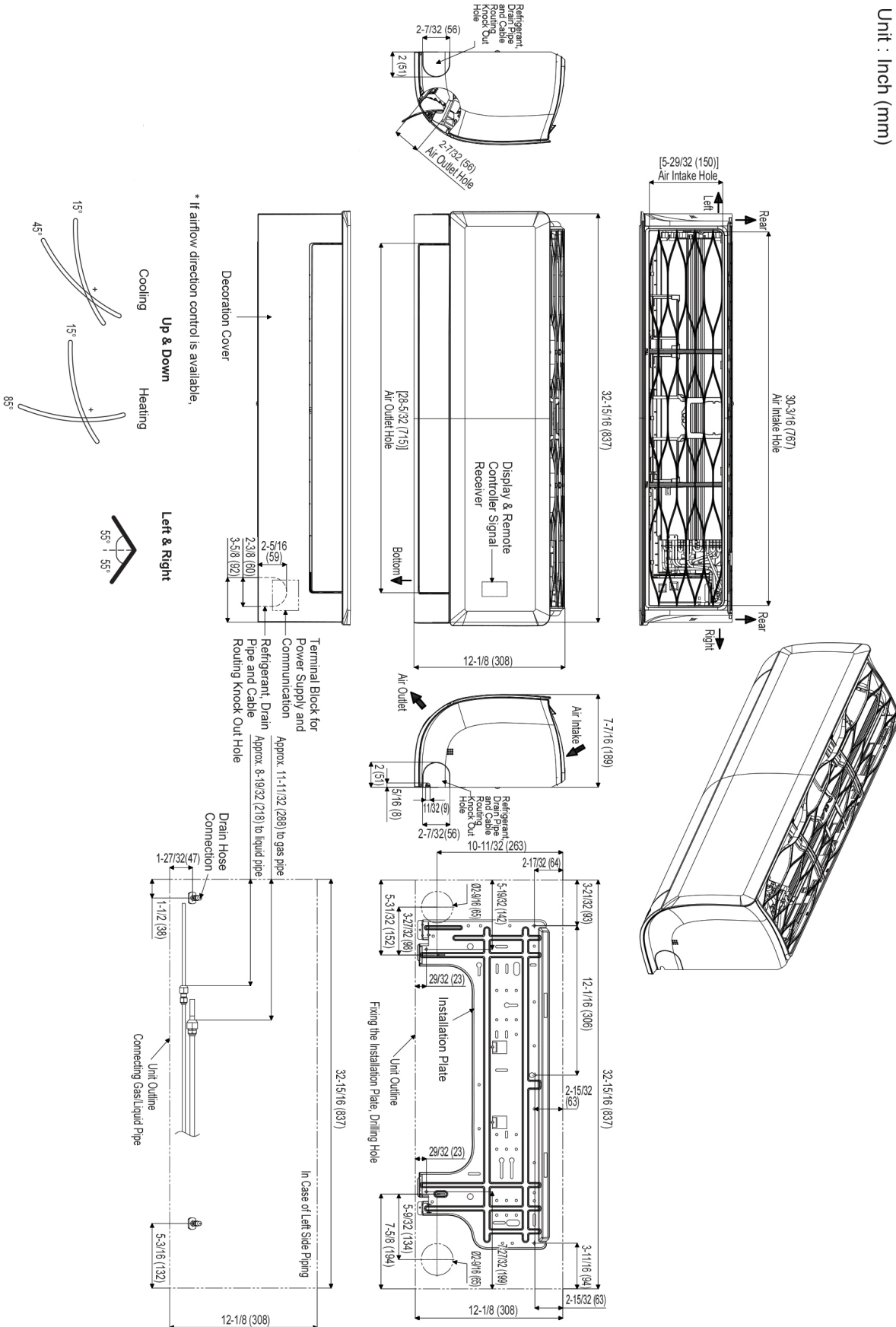

Job Name/Location:

Tag No.:

Date:

For:	File	Resubmit
	Approval	Other

PO No.:

Architect: GC:

Engr: Mech:

Rep: (Company) (Project Manager)



**KNUAB121A**  
R32 Multi F Wall Mounted High Efficiency Indoor Unit  
12,000 Btu/h



**Performance:**

Nominal Cooling Capacity (Btu/h)	12,000
Nominal Heating Capacity (Btu/h)	13,600

Cooling Nominal Test Conditions:  
Indoor: 80°F DB / 67°F WB  
Outdoor: 95°F DB / 75°F WB

Heating Nominal Test Conditions:  
Indoor: 70°F DB / 60°F WB  
Outdoor: 47°F DB / 43°F WB

**Electrical:**

Power Supply (V/Hz/Ø) <sup>1,2</sup>	208-230/60/1
Rated Current (A)	0.4

**Piping:**

Installed Liquid Pipe (in., O.D.)	Ø1/4
Installed Vapor Pipe (in., O.D.)	Ø3/8
Liquid Connection (in., O.D.)	Ø1/4
Vapor Connection (in., O.D.)	Ø3/8
Drain (in., O.D. / I.D.)	27/32, 5/8
Temperature Sensor	Thermistor

**Controls Features:**

- Left / right and up / down auto swing
- 24-Hour on/off timer
- Auto operation
- Auto restart
- Group control
- Inverter (variable speed fan)
- Jet cool / Jet heat
- 3M Micro Dust Filter
- Self-cleaning indoor coil
- Sleep mode
- R32 leak detection sensor
- Built-in Wi-Fi via Smart ThinQ app
- Compatible with applicable Single Zone Outdoor Units (see single zone literature for matching system details)

**Included Accessories:**

- Wireless Remote Controller — AKB76044208

**Optional Accessories:**

- Auxiliary Heater Kit - PRARS1
- Single-Port Shutoff Valve - PRHPZ010A

**Controller Options:**

- MultiSITE™ CRC\* Controllers
- Simple Remote Controllers
- Standard III Remote Controllers
- Deluxe Remote Controller
- Remote Temperature Button Sensor
- Dry Contacts

**Entering Mixed Air:**

Cooling (°F WB)	57 ~ 77
Heating (°F DB)	59 ~ 81

**Unit Data:**

Refrigerant Type	R32
Refrigerant Control	EEV
Sound Pressure (H/M/L) (±3 dB[A]) <sup>3</sup>	38 / 34 / 29
Primary Filter	Washable Pre-filter
Secondary Filter	3M Micro Dust
Net Weight (lbs.)	19.73
Shipping Weight (lbs.)	22.7

**Fan:**

Type	Cross Flow
Quantity	1
Motor/Drive	Brushless Digitally Controlled/Direct
Air Flow H/M/L (CFM)	282 / 233 / 177
Dehumidification (pts./hr.)	2.75

**Notes:**

1. Acceptable operating voltage: 187V-253V.
2. The power wiring and the communication wiring from the outdoor unit to the indoor unit, or from the branch distribution unit to the indoor unit is field supplied and must be stranded, shielded or unshielded (if shielded, it must be grounded to the chassis of the outdoor unit only). All wiring must comply with applicable local and national codes.
  - a. Power Wiring and Communication Wiring from Outdoor Unit to Indoor Unit (No. x AWG) 3 x 14 / 2 x 18.
  - b. Power Wiring and Communication Wiring from Branch Distribution Unit to Indoor Unit (No. x AWG) 3 x 14 / 2 x 18.
3. Sound Pressure levels are tested in an anechoic chamber under ISO Standard 3745.
4. See Engineering Manual for sensible and latent capacities.
5. The indoor unit comes with a dry helium charge.
6. Corresponding refrigerant piping length is in accordance with standard length of each outdoor unit and the level difference is 0 ft. All capacities are net with a combination ratio between 95 - 105%.
7. Must follow installation instructions in the applicable LG installation manual.





Job Name/Location:

Tag No.:

Date:

For:	File	Resubmit
	Approval	Other

PO No.:

Architect: GC:

Engr: Mech:

Rep: (Company) (Project Manager)



**KNUAB181A**  
**R32 Multi F Wall Mounted High Efficiency Indoor Unit**  
 18,000 Btu/h



**Performance:**

Nominal Cooling Capacity (Btu/h)	18,000
Nominal Heating Capacity (Btu/h)	21,600

Cooling Nominal Test Conditions:  
 Indoor: 80°F DB / 67°F WB  
 Outdoor: 95°F DB / 75°F WB

Heating Nominal Test Conditions:  
 Indoor: 70°F DB / 60°F WB  
 Outdoor: 47°F DB / 43°F WB

**Electrical:**

Power Supply (V/Hz/Ø) <sup>1,2</sup>	208-230/60/1
Rated Current (A)	0.4

**Piping:**

Installed Liquid Pipe (in., O.D.)	Ø1/4
Installed Vapor Pipe (in., O.D.)	Ø1/2
Liquid Connection (in., O.D.)	Ø3/8
Vapor Connection (in., O.D.)	Ø5/8
Drain (in., O.D. / I.D.)	27/32, 5/8
Temperature Sensor	Thermistor

**Controls Features:**

- Left / right and up / down auto swing
- 24-Hour on/off timer
- Auto operation
- Auto restart
- Group control
- Inverter (variable speed fan)
- Jet cool / Jet heat
- 3M Micro Dust Filter
- Self-cleaning indoor coil
- Sleep mode
- R32 leak detection sensor
- Built-in Wi-Fi via Smart ThinQ app
- Compatible with applicable Single Zone Outdoor Units (see single zone literature for matching system details)

**Included Accessories:**

- Wireless Remote Controller — AKB76044208

**Optional Accessories:**

- Auxiliary Heater Kit - PRARS1
- Single-Port Shutoff Valve - PRHPZ010A

**Controller Options:**

- MultiSITE™ CRC\* Controllers
- Simple Remote Controllers
- Standard III Remote Controllers
- Deluxe Remote Controller
- Remote Temperature Button Sensor
- Dry Contacts

**Entering Mixed Air:**

Cooling (°F WB)	57 ~ 77
Heating (°F DB)	59 ~ 81

**Unit Data:**

Refrigerant Type	R32
Refrigerant Control	EEV
Sound Pressure (H/M/L) (±3 dB[A]) <sup>3</sup>	44 / 38 / 34
Primary Filter	Washable Pre-filter
Secondary Filter	3M Micro Dust
Net Weight (lbs.)	26.0
Shipping Weight (lbs.)	31.8

**Fan:**

Type	Cross Flow
Quantity	1
Motor/Drive	Brushless Digitally Controlled/Direct
Air Flow H/M/L (CFM)	558 / 438 / 353
Dehumidification (pts./hr.)	5.50

**Notes:**

1. Acceptable operating voltage: 187V-253V.
2. The power wiring and the communication wiring from the outdoor unit to the indoor unit, or from the branch distribution unit to the indoor unit is field supplied and must be stranded, shielded or unshielded (if shielded, it must be grounded to the chassis of the outdoor unit only). All wiring must comply with applicable local and national codes.
  - a. Power Wiring and Communication Wiring from Outdoor Unit to Indoor Unit (No. x AWG) 3 x 14 / 2 x 18.
  - b. Power Wiring and Communication Wiring from Branch Distribution Unit to Indoor Unit (No. x AWG) 3 x 14 / 2 x 18.
3. Sound Pressure levels are tested in an anechoic chamber under ISO Standard 3745.
4. See Engineering Manual for sensible and latent capacities.
5. The indoor unit comes with a dry helium charge.
6. Corresponding refrigerant piping length is in accordance with standard length of each outdoor unit and the level difference is 0 ft. All capacities are net with a combination ratio between 95 - 105%.
7. Must follow installation instructions in the applicable LG installation manual.
8. Multi compatible 18k IDUs include socket adapters for refrigerant pipe connections with Multi F systems.



**KNUAB181A**  
**R32 Multi F Wall Mounted High Efficiency Indoor Unit**  
 18,000 Btu/h



Tag No.: \_\_\_\_\_

Date: \_\_\_\_\_

PO No.: \_\_\_\_\_

Unit : Inch (mm)

