

Job Name/Location:

Tag No.:

Date:

For:	File	Resubmit
	Approval	Other_____

PO No.:

Architect:

GC:

Engr:

Mech:

Rep:

(Company)

(Project Manager)

PT-QAGW0

2' x 2' Cassette Panel

For Multi V™/Single-Zone /Multi F 4-Way Ceiling-Cassette Indoor Units



Unit Data:

Color	White
RAL Color Code	RAL 9003
RGB Color Code	236 - 236 - 231
Material	ABS XG571
Net Dimensions (W x H x D, in.)	24-13/32 x 1-3/8 x 24-13/32
Shipping Dimensions (W x H x D, in.)	27-3/32 x 5 x 26-1/2
Net Weight (lbs.)	6.3
Shipping Weight (lbs.)	8.6
Display LED Color	Green
Filter	Washable

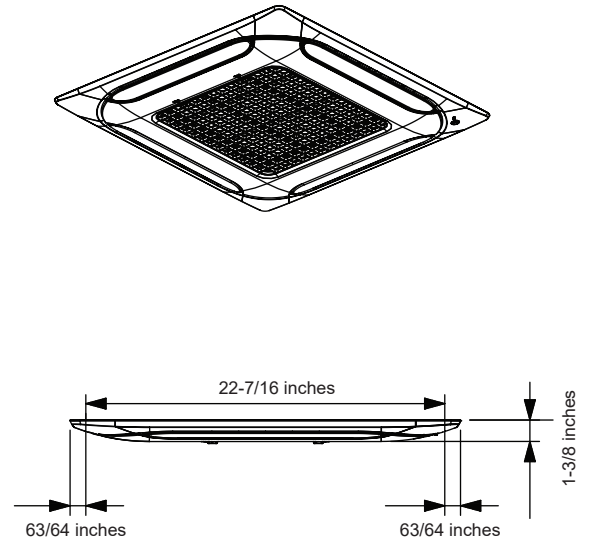
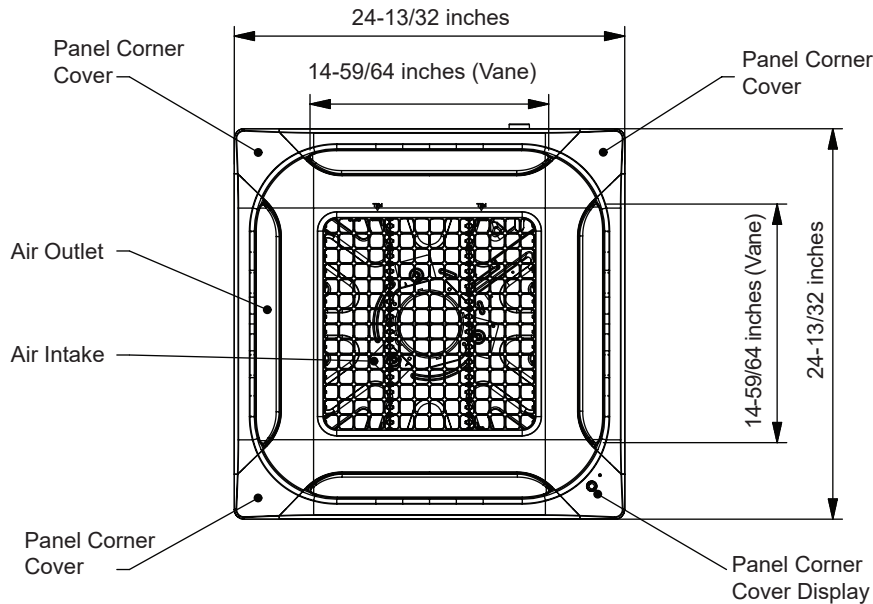

Job Name/Location:

Tag No:

Date:

For:	File	Resubmit
	Approval	Other_____

PO No.:

Architect: _____ GC: _____

Engr: _____ Mech: _____

Rep: _____
(Company) (Project Manager)



KNADB091A
R32 Multi F 2 x 2 Four-Way Ceiling Cassette Indoor Unit
9,000 Btu/h



Performance:

Nominal Cooling Capacity (Btu/h)	9,000
Nominal Heating Capacity (Btu/h)	10,400

Cooling Nominal Test Conditions:
Indoor: 80°F DB / 67°F WB
Outdoor: 95°F DB / 75°F WB

Heating Nominal Test Conditions:
Indoor: 70°F DB / 60°F WB
Outdoor: 47°F DB / 43°F WB

Electrical:

Power Supply (V/Hz/Ø) ^{1,2}	208-230/60/1
Rated Amps (A)	0.25

Piping:

Installed Liquid Pipe (in., O.D.)	Ø1/4
Installed Vapor Pipe (in., O.D.)	Ø3/8
Liquid Connection (in., O.D.)	Ø1/4
Vapor Connection (in., O.D.)	Ø3/8
Drain (in., O.D. / I.D.)	1-1/4, 1
Temperature Sensor	Thermistor

Controls Features:

- Two thermistor control
- 24-Hour on / off timer
- Auto operation
- Auto restart
- Swirl swing
- Control lock function
- Drain pump
- Group control
- Inverter (variable speed fan)
- Jet cool
- R32 leak detection sensor
- Compatible with accessory Wi-Fi module
- Compatible with applicable Single Zone Outdoor Units (see single zone literature for matching system details)

Included Accessories:

- Wireless Remote Controller - PWLSSB21H

Required Accessories:

- Panel (24-13/32" x 24-13/32") - PT-QAGW0

Optional Accessories:

- Ventilation Flange³ - PTVK430
- Auxiliary Heater Kit - PRARH1
- Wi-Fi Module - PWFMD200
- Single-Port Shutoff Valve - PRHPZ010A

Controller Options:

- MultiSITE™ CRC* Controllers
- Simple Remote Controllers
- Standard III Remote Controllers
- Deluxe Remote Controller
- Remote Temperature Button Sensor
- Dry Contacts

Entering Mixed Air:

Cooling (°F DB)	57 ~ 77
Heating (°F WB)	59 ~ 81

Unit Data:

Refrigerant Type	R32
Refrigerant Control	EEV
Sound Pressure (H/M/L) dB(A) ⁴	36 / 33 / 30
Standard Filter ⁵	Washable
Net Weight (lbs.)	28.4
Shipping Weight (lbs.)	34
Panel Net Weight (lbs.)	6.3
Panel Shipping Weight (lbs.)	8.6

Fan:

Type	Turbo
Quantity	1
Motor/Drive	Brushless Digitally Controlled/Direct
Air Flow H/M/L (CFM)	300 / 265 / 230
Dehumidification Rate (pts./hr.)	1.5

Notes:

1. Acceptable operating voltage: 187V-253V.
2. The power wiring and the communication wiring from the outdoor unit to the indoor unit, or from the branch distribution unit to the indoor unit is field supplied and must be stranded, shielded or unshielded (if shielded, it must be grounded to the chassis of the outdoor unit only). All wiring must comply with applicable local and national codes.
 - a. Power Wiring and Communication Wiring from Outdoor Unit to Indoor Unit (No. x AWG) 3 x 14 / 2 x 18.
 - b. Power Wiring and Communication Wiring from Branch Distribution Unit to Indoor Unit (No. x AWG) 3 x 14 / 2 x 18.
3. Must comply with applicable codes for fire isolation dampers.
4. Sound Pressure levels are tested in an anechoic chamber under ISO Standard 3745.
5. Removable Washable Filter size: 14" x 14" x 1".
6. See Engineering Manual for sensible and latent capacities.
7. The indoor unit comes with a dry helium charge.
8. Corresponding refrigerant piping length is in accordance with standard length of each outdoor unit and the level difference is 0 ft. All capacities are net with a combination ratio between 95 - 105%.
9. Must follow installation instructions in the applicable LG installation manual.



For a complete list of available accessories, contact your LG representative.

For continual product development, LG reserves the right to change specifications without notice.

© LG Electronics U.S.A., Inc., Englewood Cliffs, NJ. All rights reserved. "LG Life's Good" is a registered trademark of LG Corp. /www.lghvac.com

