

# WM9500HKA

LG SIGNATURE Washer

LG SIGNATURE

KEY FEATURES

- 5.8 cu.ft. MEGA Capacity
- Premium Black Stainless Steel
- TurboWash® Technology - Save Up to 30 minutes Per Load\*
- SideKick™ Compatible (WD205CK)
- Ergonomic Angled Door for Easier Access
- Full Touch On-Door Control Panel
- Smart ThinQ™ Technology
- Steam Technology
- ENERGY STAR® Most Efficient 2016
- 10-Year Warranty on Direct Drive Motor



\*Compared to an LG front load washer without TurboWash. Based on AHAM-HLW-1-2010 test protocol. Cotton / Normal or comparable cycle at default settings, 8 lb. loads. Excludes quick wash or comparable cycles intended for small, lightly soiled loads only.

PRODUCT FEATURES

CAPACITY	
Capacity	5.8 cu. ft.
APPEARANCE	
Design Look	Front Control
Full Touch On-Door Control Panel with LED Display	•
Touch Buttons	•
ENERGY	
ENERGY STAR® Most Efficient 2016	•
CEE Tier	3
WASH PROGRAMS	
No. of Programs	14
Wash Programs	Normal, Perm. Press, Delicates, Speed Wash, TubClean™, Sanitary, Allergiene™, Heavy Duty, BrightWhites™, Towels, Rinse+Spin, Download, Jumbo Wash, Bedding
No. of Options	13
Options	Prewash, Delay Wash, Extra Rinse, Child Lock, ColdWash™, FreshCare™, Steam, TurboWash™, Custom Program, Drum Light, Smart Grid, Remote Start, Wi-Fi Connect
No. of Wash/Rinse Temps	5 (Extra Hot, Hot, Warm, Cold, Tap Cold (All Cold Rinses))
Spin Speeds	Extra High (1,300 max.), High, Medium, Low, No Spin
No. of Water Levels	Automatically adjusts to the size of load
No. of Soil Levels	5
FABRIC CARE FEATURES	
TurboWash® 2.0 Technology	•
Steam Technology	•
Allergiene™ Cycle (AAFA Certified)	•
Sanitary Cycle	•
ColdWash™ Option	•
SenseClean™ System	•
CONVENIENCE FEATURES	
Ergonomic Angled Door	•
TrueBalance™ Anti-Vibration System	•
4 Tray Dispenser	Prewash, Main Wash (with liquid detergent cup), Bleach, Fabric Softener
LoDecibel™ Quiet Operation	•
End of Cycle Signal	•
LoadSense	•
Child Lock	•
Auto Suds Removal	•
Forced Drain System	•
Leveling Legs	4 Adjustable Legs

SMART THING™ TECHNOLOGY	
WiFi	•
SmartDiagnosis™ (v3.0)	•
Smart Grid Ready	•
Smart Access	•
Smart Adapt	•
Energy Monitoring	•
Laundry Starts	•
MOTOR AND AGITATOR	
Motor Type	Inverter Direct Drive Motor
Motor Speed / Max RPM	Variable / 1,300
Axis	Horizontal
MATERIALS AND FINISHES	
NeveRust™ Stainless Steel Drum	•
Cabinet	PCM
Control Panel	Plastic
Top Plate	Painted
Door Rim	Glass/Chrome
Door Cover	Dark Black Tinted Square Cover
Door Opening	42 1/8"
Available Colors	Black Stainless Steel (K)
POWER SOURCE	
Ratings	UL Listed
Electrical Requirements	120V, 10 Amps
Type	Electric
OPTIONS	
Pedestal	WDP5K
Pedestal (WxHxD)	29" x 14 1/8" x 29 2/5"
ACCESSORIES	
Hose Included	•
DIMENSIONS/CLEARANCES/WEIGHTS	
Product (WxHxD)	29 5/8" x 41 3/16" x 33 1/16" (55 15/16" D with door open)
Carton (WxHxD)	31 5/16" x 44 15/16" x 35 5/8"
Weight (Product/Carton)	239 lbs / 263.3 lbs
LIMITED WARRANTY	
Limited Warranty	1 Year Parts and Labor, 10 Years on Direct Drive Motor, Lifetime on Drum
UPC CODES	
WM9500HKA Washer	048231 017039
DLEX9500K Electric Dryer	048231 017046
DLGX9501K Gas Dryer	048231 017053
WDP5K Pedestal	048231 018364

© 2016 LG Electronics USA, Inc. All rights reserved. "LG Life's Good" is a registered trademark of LG Corp. All other product and brand names are trademarks or registered trademarks of their respective owners. Design, features and specifications are subject to change without notice. Non-metric weights and measurements are approximate. Some features may require Internet access. Content and services may vary by product and are subject to change without notice. 12/1/16

# DLEX9500K DLGX9501K

LG SIGNATURE Dryer

LG SIGNATURE

KEY FEATURES

- 9.0 cu.ft. MEGA Capacity
- Premium Black Stainless Steel
- TurboSteam™ Technology
- Ergonomic Angled Door for Easier Access
- Full Touch On-Door Control Panel
- 14 Drying Programs
- Smart ThinQ™ Technology
- Sensor Dry System



PRODUCT FEATURES

## CAPACITY

Capacity	9.0 cu. ft.
----------	-------------

## APPEARANCE

Design Look	Front Control
Full Touch On-Door Control Panel with LED Display	•
Touch Buttons	•

## DRYER PROGRAMS

No. of Programs	14
Programs (Sensor Dry)	Cotton/Normal, Perm. Press/Casual, Towels, Delicates, Heavy Duty, TurboSteam®, Steamanitary™, Bedding, LowTemp Dry, Anti-Bacterial, Jumbo Dry, Download/Super Dry
Programs (Manual)	Speed Dry, Air Dry
No. of Options	13
Options	More Time, Less Time, Custom Program, PGM Save, Damp Dry Signal, Wrinkle Care, Child Lock, Wi-Fi Connect, Drum Light, Energy Saver, TurboSteam®, Smart Grid, Remote Start
Temperature Settings	High, Medium High, Medium, Low, Ultra Low
Drying Levels	Very Dry, More Dry, Normal Dry, Less Dry, Damp Dry
Manual Dry Times	60 min., 50 min., 40 min., 30 min., 20 min., More Time/Less Time

## CONVENIENCE FEATURES

Ergonomic Angled Door	•
LoDecibel™ Quiet Operation	•
End of Cycle Signal	•
Drum Light	•
Reversible Door	•
FlowSense™ Duct Clogging Indicator	•
Venting Option	Electric: 4 Way Venting / Gas: 3 Way Venting
Leveling Legs	4 Adjustable Legs
Remaining Time Display/Status Indicator(s)	•
3 Minute Installation Check	•
SmartDiagnosis™	• (v 3.0)

## SMART THING™ TECHNOLOGY

WiFi	•
SmartDiagnosis™	•
Smart Grid Ready	•
Energy Monitoring	•
Black Box	•
Remote Control	•
Home Chat	•

## MATERIALS AND FINISHES

NeveRust™ Stainless Steel Drum	•
Tub Rear	•
Cabinet	Painted Steel
Control Panel	Plastic (Door Assembly)
Top Plate	Porcelain
Door	Glass/Chrome
Door Cover	Dark Blue Tinted Square Cover
Available Colors	Black Stainless Steel (K)

## POWER SOURCE

Ratings	CSA Listed
Electrical Requirements	120V, 15 Amps (Gas) / 240V, 30 Amps (Electric)
Type	Gas / Electric
BTU	20,000

## OPTIONS

Pedestal	WDP5K
Pedestal (WxHxD)	29" x 14 1/8" x 29 2/5"

## ACCESSORIES

Hose Included	•
---------------	---

## DIMENSIONS/CLEARANCES/WEIGHTS

Product (WxHxD)	29" x 40 7/8" x 33 3/8" (56" with door open)
Carton (WxHxD)	31 5/16" x 44 15/16" x 35 5/8"
Weight (Product/Carton) Electric	157.4 lbs / 177.2 lbs
Weight (Product/Carton) Gas	160.7 lbs / 180.5 lbs

## LIMITED WARRANTY

Limited Warranty	1 Year Parts and Labor
------------------	------------------------

## UPC CODES

DLEX9500K Electric Dryer	048231 017046
DLGX9501K Gas Dryer	048231 017053
WM9500HKA Washer	048231 017039
WDP5K Pedestal	048231 018364
WD205CK SideKick™ Pedestal (for washer only)	048231 017121

※ 본 도면은 PDF파일 관리로 전환하면서 신규 생성되는 도면임.

RELEASING THIS DRAWING WITHOUT PERMISSION LG Electronics SHOULD BE ACCUSED ACCORDING TO THE LAWS AND COMPANY RULES.  
이 도면은 LG전자의 자산으로 불법 유출시 관계법과 회사규정에 의해 처벌됨.

SEC. WORK	가	나	다	PRINTING DEGREE		MATERIAL AND PRINTING DESCRIPTION	LG MODEL 명	SUFFIX	LANGUAGE	PAGE	REMARK
	BRAND	MODEL	P/NO.	EXTERIER	INTERIER						
V	KENMORE	WDP4*	3282ER4001V	1	1	모조지 100g OFFSET 인쇄	LWP-277(8)*	A**EECI	ENG/ SPN/ FRE	16	PEDESTAL

<< 주 기 >>

1. 재질, 인쇄방법, 인쇄도수, 외곽치수등은 작업표에 준한다.
2. 인쇄내용, 문자크기 및 형상, 선의 굵기 등은 설계에서 제시된 FILM에 준함.
3. 외곽치수는 절단후 치수임.
4. 양산전에 설계 한도를 득할 것.
5. 본 부품에 금지물질이 포함되지 않도록 하고, 상세내용은 LG(63)-A-5501-34를 만족할 것

<< NOTES >>

1. Material, printing and exterier size are refer to work tables.
2. Printing, text size and line are based on LG design film.
3. Exterier size on the drawing is cutting line.
4. Before product controlled by criteria sample.
5. The part should not contain prohibited substances(Pb,Cd,Hg,Cr+6,PBB,PBDE) and details should comply with LG standard of LG(63)-A-5501-34

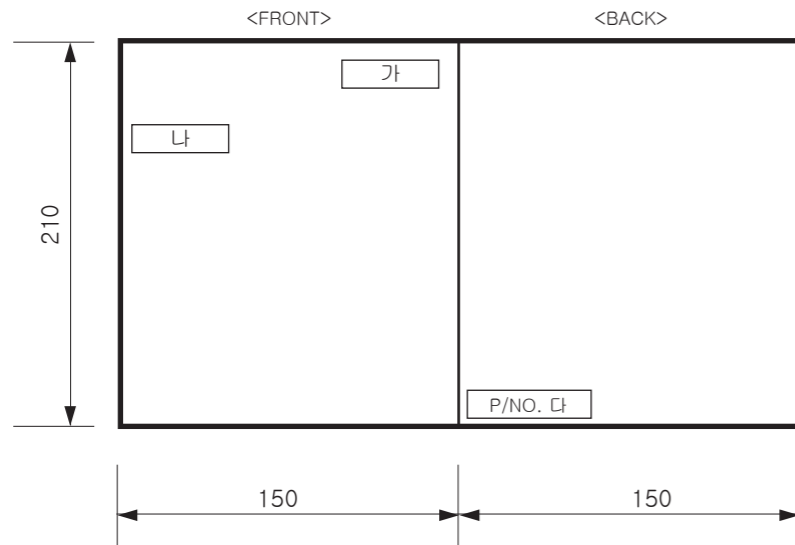

PDF ILLUSTRATOR  
DR COMPLETED  
도면 DR 완료  
완료일: 10.02.11

REV. NO. 기호	REVISION DESCRIPTION 변경 사항	REF. NO. 시방 번호	DATE 년/월/일	PREPARED 시방자	APPROVED 승인자
△	인쇄내용 변경	AWCR107257	11/11/29	황지성	강종우
△	인쇄내용 변경	AWCR203030	12/05/25	황지성	김 권
△	인쇄내용 변경	EAGE800320	14/08/25	박종일	김 권
△	인쇄내용 변경	EAGE900308	14/09/16	박종일	김 권

TRIG.	UNIT	mm	SCALE	1/1	T I T L E
MODELING	DESIGNED	REVIEWED	CHECKED	APPROVED	
X	김희정 10.02.11	X	X	조한기 10.02.11	DWG. No. 3828ER4001V
LG 전자 (주) LG Electronics Inc.				RELATED DWG.	

## PEDESTAL KIT

---

### INSTALLATION INSTRUCTIONS

Before beginning installation, read these instructions carefully. This will simplify installation and ensure that the pedestal is installed correctly and safely. Leave these instructions near the pedestal after installation for future reference.

For washer, dryer,  
and combination

## TROUSSE DE PIÉDESTAL

---

### DIRECTIVES D'INSTALLATION

Avant de commencer l'installation, lisez attentivement ces instructions. Cela simplifiera votre installation et assurera que le piédestal est installé correctement et en toute sécurité. Conservez ces instructions à proximité du piédestal après son installation, pour référence future.

Pour machine à laver, sècheuse,  
et combo

## JUEGO DE PEDESTAL

---

### INSTRUCCIONES DE INSTALACIÓN

Antes de comenzar la instalación, lea atentamente estas instrucciones. Esto simplificará la instalación y asegurará que el pedestal está instalado en forma correcta y segura. Conserve estas instrucciones cerca del pedestal luego de la instalación para futuras consultas.

Para lavadora, secadora,  
y combo

# IMPORTANT: Read and follow these instructions.

## NOTICE

The installer must have electrical and mechanical training and acceptable knowledge in the required work.

Safety is foremost---both your own and that of other people. Many important safety instructions are provided in this instruction and your appliance. Always read and observe all safety instructions.

## WARNING

### Excessive Weight Hazard

Two or more people may be needed to install and move the appliance and pedestal assembly. Do not allow children to play on the drawer. Do not step on the handle.

## NOTE

A firm, solid floor is even more critical to a front-loading washer than to a top-loader. If your floor is wooden and /or frame construction, you may need to reinforce it. Front-loaders have substantially faster spin speed than top-loaders, causing greater vibration. If the floor is not solid, your washer will vibrate.

## NOTE

If a drip pan must be used, take extra care to follow the instructions provided with the drip pan and make sure the leveling feet are adjusted for firm and even contact with the pan. Use of drip pans and failure to properly level the machine may result in increased vibration and noise during operation.

## Included Accessories



4 Holder



eighteen  
4x20mm  
Truss tapite



Drawer Divided

## Tools Needed



11/16" or 17mm  
Open End Wrench

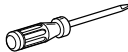

Phillips  
screwdriver

## WASHER/COMBO INSTALLATION

- 1 Remove pedestal, installation hardware, and instructions from the shipping carton.
- 2 Before installing the pedestal, remove foreign objects on the floor, clean the floor. Dust, water, oil, detergent and so on could cause vibration due to bad contact of legs with floor.

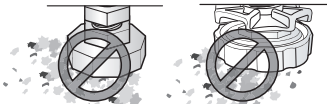

- 3 Level the pedestal on the clean place by adjusting the feet.

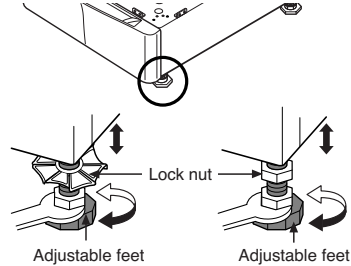

## NOTE

Do not extend the legs no more than necessary to level the washer. The more the legs are extended, the more the washer will vibrate.

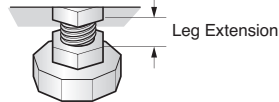

- ▶ After the washer is leveled, tighten the lock nuts up toward the base of the washer using the wrench. All four lock nuts should be tightened.

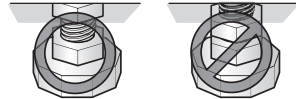

- 4 Position the washer/combo on top of the pedestal.

## NOTE

Because of the weight of the washer/combo, two or more people may be needed.

## NOTE

If the washer or combo was previously installed, unplug it, disconnect the inlet hose (s) from the faucet (s), disconnect the drain hose, and drain all hoses.

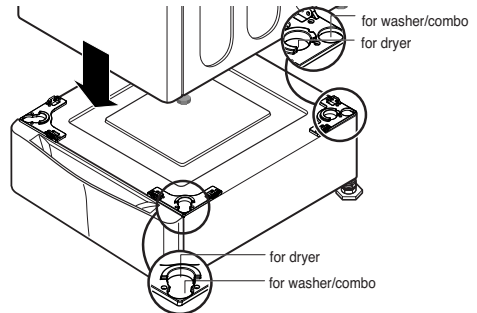



**5** Level the washer/combo on the pedestal by adjusting the feet.

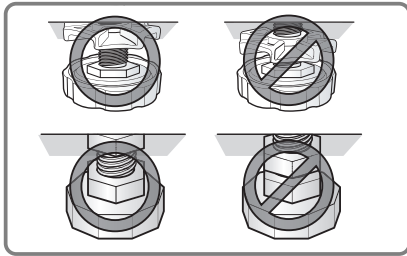
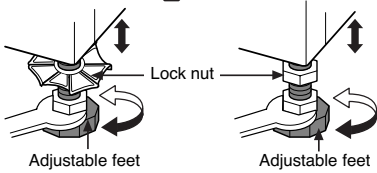
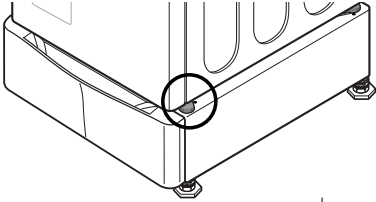

**6** Make sure the holes on the pedestal align with the holes in the appliance, then install 4 screws at each corner to securely attach the appliance to the pedestal.

**NOTE**

If the screws are not installed properly, noise and vibration may result.

For WASHER: 16 SCREWS

For DRYER: 8 SCREWS

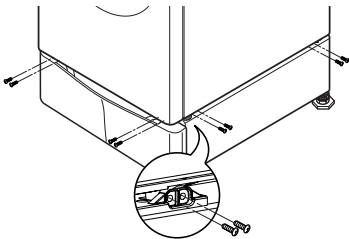

**7** Move the washer/combo to the desired place.

**NOTE**

The appliance and pedestal assembly must be placed on a solid and level floor for proper operation. Adjust the legs of the appliance and pedestal by turning with a wrench. Then, adjust the lock nut toward the pedestal while holding the pedestal leg using a wrench.

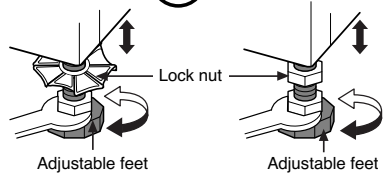
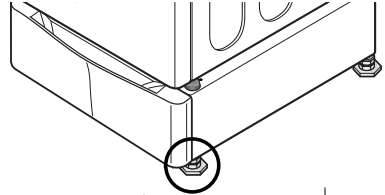

**NOTE**

**Diagonal Check**

When pushing down the edges of the washing machine top plate diagonally, the machine should not move up and down at all. (Please check both directions.) If the machine rocks when pushing the machine top plate diagonally, adjust the feet again.

**NOTE**

To make sure that the washer is properly level, run the washer with a test load: place approximately 6 pounds of laundry in the machine. Then press **POWER**, press **RINSE+SPIN**, and then press the **START/PAUSE** button. See the following sections for additional information on cycle selection and operation. Verify that the washer does not rock or vibrate excessively during the spin cycle. If the washer vibrates or shakes, adjust the leveling feet until the washer is stable and retest.

## DRYER INSTALLATION

- 1 Remove pedestal, installation hardware, and instructions from the shipping carton.
- 2 Insert the T-clip of the 4 retainers into the dryer base as shown. Press up on the back of the clip and pull outward to lock into place.

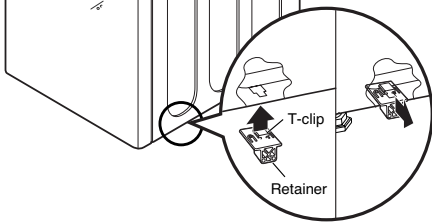

- 3 Position dryer on top of the pedestal.

### NOTE

Because of the weight of the dryer, two or more people may be needed.

### NOTE

If dryer was previously installed, uninstall it as follows:

#### A. Uninstalling an electric dryer:

- 1) Unplug the power supply cord.
- 2) Pull the dryer away from the wall enough to loosen the vent clamp. Loosen the clamp and carefully remove the exhaust vent from the dryer exhaust outlet.

#### B. Uninstalling a gas dryer:

- 1) Unplug power supply cord.
- 2) Turn off the gas supply.
- 3) Pull the dryer away from the wall enough to loosen the vent clamp. Loosen the clamp and carefully remove the exhaust vent from the dryer exhaust outlet.

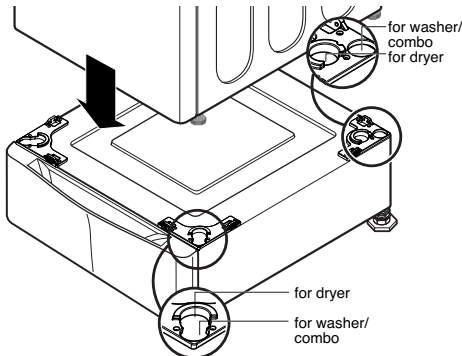

- 4 Make sure the holes on the pedestal align with the holes in the appliance, then install 2 screws at each corner to securely attach the appliance to the pedestal.

### NOTE

If the screws are not installed properly, noise and vibration may result.

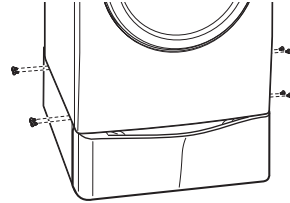

- 5 Move the dryer to the desired place.

### NOTE

The appliance and pedestal assembly must be placed on a solid and level floor for proper operation. Adjust the legs of the appliance and pedestal by turning with a wrench. Then, adjust the lock nut toward the pedestal while holding the pedestal leg using a wrench.

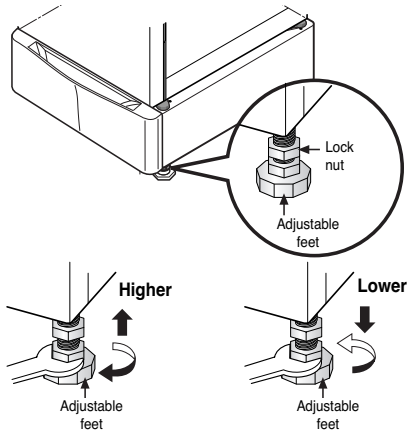

# WARRANTY

**LG Electronics Inc.**, Will repair or at its option replace, without charge, your product if it proves to be defective material or workmanship under normal use during the warranty period set forth below, effective from the date of original consumer purchase of the product. This limited warranty is good only to the original purchaser of the product and effective only when used in the United states including Alaska, Hawaii, and U.S. Territories; and Canada.

<b>WARRANTY PERIOD:</b>	<b>HOW SERVICE IS HANDLED:</b>
1Year from the Date of Purchase.	Call 1-800-243-0000 (USA) or 1-888-LGCANADA and choose the appropriate prompt. Please have product type, model number, serial number, and ZIP code ready.

**THIS WARRANTY IS IN LIEU OF ANY OTHER WARRANTIES, EXPRESS OR IMPLIED, INCLUDING WITHOUT LIMITATION, ANY WARRANTY OF MERCHANTABILITY OR FITNESS FOR A PARTICULAR PURPOSE. TO THE EXTENT ANY IMPLIED WARRANTY IS REQUIRED BY LAW, IT IS LIMITED IN DURATION TO THE EXPRESS WARRANTY PERIOD ABOVE. LG WILL NOT BE LIABLE FOR ANY CONSEQUENTIAL, INDIRECT, OR INCIDENTAL DAMAGES OF ANY KIND, INCLUDING LOST REVENUE OR PROFITS, IN CONNECTION WITH THE PRODUCT.**

**SOME STATES DO NOT ALLOW LIMITATION ON HOW LONG AN IMPLIED WARRANTY LASTS OR THE EXCLUSION OF INCIDENTAL OR CONSEQUENTIAL DAMAGES, SO THE ABOVE LIMITATIONS OR EXCLUSIONS MAY NOT APPLY TO YOU.**

**THIS LIMITED WARRANTY DOES NOT APPLY TO:**

1. Service trips to your home to deliver, pick up, and/or install the product, instruct, or replace house fuses or correct wiring, or correction of unauthorized repairs; and
2. Damages or operating problems that result from misuse, abuse, operation outside environmental specifications or contrary to the requirements or precautions in the Operating Guide, accident, vermin, fire, flood, improper installation, acts of God, unauthorized modification or alteration, incorrect electrical current or voltage, or commercial use, or use for other than intended purpose.
3. Therefore, the cost of repair or replacement of such a defective product shall be borne by the consumer.

**CUSTOMER INTER-ACTIVE CENTER NUMBERS:**

<b>To Prove Warranty Coverage</b>	<b>Retain your Sales Receipt to prove date of purchase.</b> A copy of your Sales Receipt must be submitted at the time warranty service is provided.
<b>To Obtain Nearest Authorized Service Center or Sales Dealer, or to Obtain Product, Customer, or Service Assistance</b>	Call 1-800-243-0000 or 1-888-LGCANADA and choose the appropriate prompt from the menu, and have your product type, model number, serial number, and ZIP Code; or visit our website at <a href="http://www.lgservice.com">http://www.lgservice.com</a>

ENGLISH



# IMPORTANT: Lire et suivre ces instructions à la lettre

## NOTICE

L'installateur doit avoir une formation électrique et mécanique et une expérience convenable pour ce genre de travail.

La sécurité est primordiale: la vôtre et celle des autres. D'importantes instructions de sécurité sont indiquées dans ces instructions et sur votre appareil. Lire et observer attentivement toutes ces instructions de sécurité.

## ⚠ AVERTISSEMENT

### Risque dû au poids excessif de la machine:

Plus de deux personnes sont nécessaires pour déplacer et installer l'appareil et l'assemblage du piédestal. Ne pas laisser les enfants jouer sur le tiroir. Ne pas marcher sur le manche.

## REMARQUE

Un plancher robuste et solide est essentiel pour une laveuse à chargement frontal qu'un modèle à chargement sur le dessus. Si le plancher est en bois et/ou autre construction, il faudra le renforcer. La laveuse à chargement frontal effectue un essorage beaucoup plus rapide que les autres appareils, causant ainsi plus de vibrations. Si le plancher n'est pas robuste, la laveuse peut vibrer. L'on entendra et sentira les vibrations dans la maison.

## REMARQUE

L'utilisation d'une cuvette est déconseillée. Elle pourrait empêcher la mise à niveau du lave-linge et donc provoquer des vibrations. Si vous devez l'utiliser, veillez à l'installer correctement.



## Accessoires inclus



4 Support



dix-huit  
4x20mm  
taraudé Truss



Divisor de cajon

## Outils nécessaires



11/16 po ou de 17 mm  
Ouvrez Clé Fin

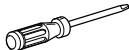

Tournevis Phillips

## INSTALLATION DE LA MACHINE A LAVER & DU COMBO

**1** Retirer le piédestal, les matériels d'installation et les instructions du carton de transport.

**2** Avant d'installer le lave-linge, enlevez tous les objets se trouvant sur le sol et nettoyez-le. La présence de poussière, d'eau, d'huile, de détergent ou autre peut provoquer des vibrations dues à un mauvais contact des pieds avec le sol.

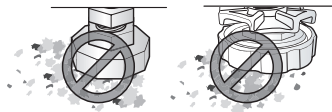

**3** Sur un emplacement propre, mettez le socle à niveau en réglant ses pieds.

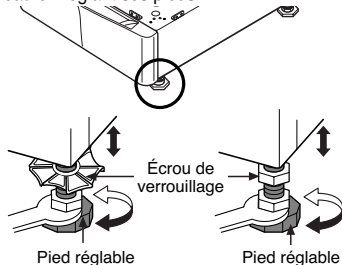

## REMARQUE

Ne pas allonger les pieds niveleurs plus que nécessaire pour mettre la laveuse de niveau. Plus les pieds sont allongés, plus la laveuse vibre.

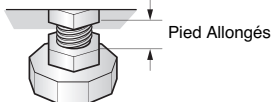

Pied Allongés

► Après que la laveuse est de niveau, serrer les écrous de verrouillage vers le haut de la base de la laveuse. Tous les écrous de verrouillage doivent être serrés.

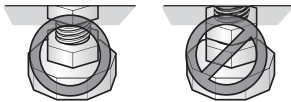

**4** Positionner la machine à laver/combo sur le haut du piédestal.

## REMARQUE

A cause du poids de la machine à laver/combo, plus de deux personnes sont nécessaires pour installation.

## REMARQUE

Si la machine à laver ou le combo sont déjà installés : les débrancher, détacher le(s) tuyau(x) d'entrée du(des) robinet(s) d'eau, détacher le tuyau d'évacuation et vider tous les tuyaux:

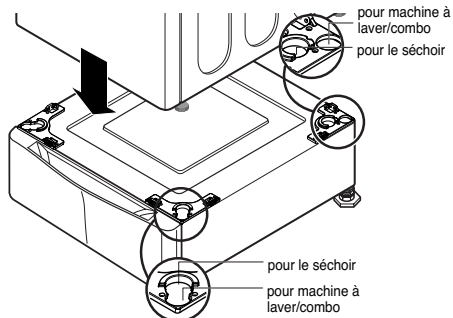

- 5** Nivelez la machine à laver/combo sur le piédestal en ajustant les pieds.

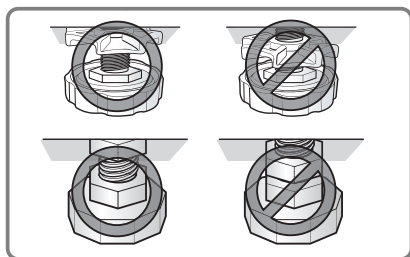
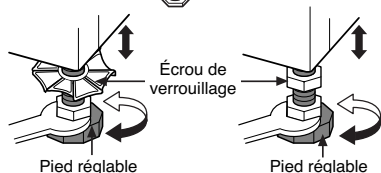
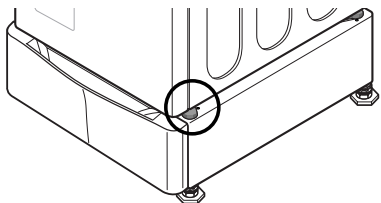

- 6** Assurez-vous que les trous du piédestal sont alignés avec les trous de l'appareil. Insérez et serrez 4 vis à chaque coin pour fixer solidement l'appareil au piédestal.

#### REMARQUE

Si les supports ne sont pas correctement installés, vous pourriez entendre du bruit et sentir des vibrations.

Placez l'appareil à l'endroit désiré.  
pour machine à laver: 16 VIS  
pour le sèche-ri: 8 VIS

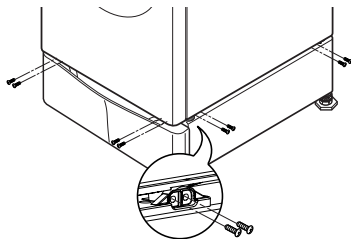

- 7** Déplacer la machine à laver/combo à l'endroit où vous voulez les disposer.

#### REMARQUE

L'appareil et le piédestal doivent être placés sur un sol solide et plat pour un fonctionnement approprié. Ajuster les pieds de l'appareil et le piédestal en tournant à l'aide d'une clé à vis. Ensuite ajuster le frein d'écrou vers le piédestal en tenant le pied du piédestal avec la clé à vis.

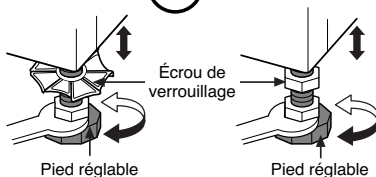
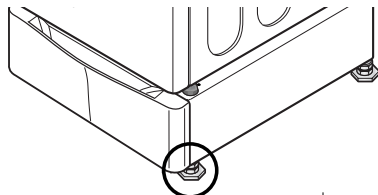

#### REMARQUE

##### Verification diagonale

En pressant les bords du dessus de la laveuse de façon diagonale, l'appareil ne devrait pas bouger (vérifier les deux sens).

Si l'appareil bascule, régler les pieds de nouveau.

#### REMARQUE

Il est essentiel que les pieds soient bien réglés. Ceci doit être fait pendant que la laveuse essore **avec une charge**. Effectuer un test de la laveuse pour s'assurer qu'elle est mise de niveau de façon appropriée. Mettre environ 6 lb de vêtements dans l'appareil. Presser **POWER** (alimentation), **RINSE+SPIN** (rinçage + essorage) et **START/PAUSE** (marche/pause), dans cet ordre. Lorsque l'appareil essore à haute vitesse, s'assurer que la laveuse est stable. Sinon, régler les pieds de façon appropriée. Utiliser la clé (fournie) pour régler les pieds jusqu'à ce qu'il n'y ait plus de vibration. Ensuite serrer les écrous de verrouillage pour empêcher tout autre changement.

## INSTALLATION DU SÉCHOIR

- 1 Retirer le piédestal, les objets d'installation et les instructions du carton de transport.
- 2 Insérer l'extrémité en forme de T des 4 souteneurs dans la base de la sècheuse comme illustré. Em appuyant sur l'arrière des souteneurs, tirez-les vers l'extérieur pour les fixer en place.

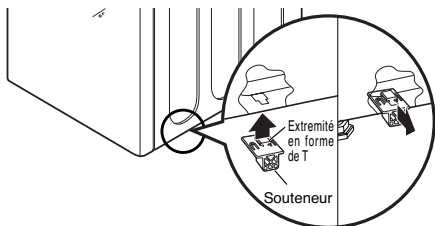

- 3 Positionner le séchoir sur le haut du piédestal.

### REMARQUE

A cause du poids du séchoir, plus de deux personnes sont nécessaires.

### REMARQUE

Au cas où le séchoir a été installé préalablement, le désinstaller selon les instructions suivantes:

#### A. Désinstaller le séchoir électrique:

- 1) Débrancher le fil électrique.
- 2) Laisser assez d'espace entre le séchoir et le mur pour permettre de desserrer la bride d'évent. Desserrer la bride et enlever l'évent d'échappement(exhaust vent) de la sortie d'air(exhaust outlet) du séchoir avec attention.

#### B. Désinstaller le séchoir de gaz:

- 1) Débrancher le fil électrique.
- 2) Couper l'alimentation en gaz.
- 3) Laisser assez d'espace entre le séchoir et le mur pour permettre de desserrer la bride d'évent. Desserrer la bride et enlever l'évent d'échappement(de la sortie d'air du séchoir avec attention.

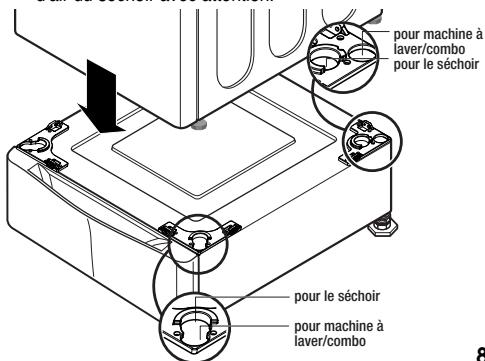

- 4 Assurez-vous que les trous du piédestal sont alignés avec les trous de l'appareil. Insérez et serrez 2 vis à chaque coin pour fixer solidement l'appareil au piédestal.

### REMARQUE

Si les supports ne sont pas correctement installés, vous pourriez entendre du bruit et sentir des vibrations.

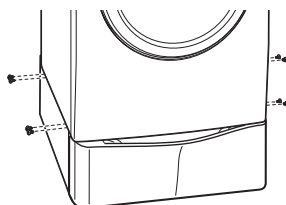

- 5 Déplacer le séchoir à l'endroit où vous voulez le disposer.

### REMARQUE

L'appareil et le piédestal doivent être placés sur un sol solide et plat pour un fonctionnement approprié. Ajuster les pieds de l'appareil et du piédestal en tournant avec une clé à vis. Ensuite ajuster le frein d'écrou vers le piédestal en tenant le pied de piédestal avec la clé à vis.

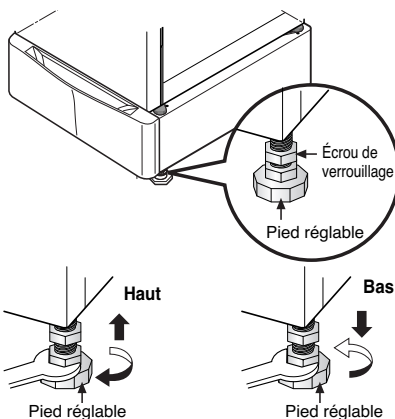

## GARANTIE

**LG Electronics Inc.**, réparera ou remplacera à sa discrétion, sans frais, le produit s'il présente un défaut de fabrication ou de main-d'œuvre dans des conditions d'utilisation normale pendant la période de garantie indiquée ci-dessous, à partir de la date d'achat d'origine par le consommateur. Cette garantie limitée s'applique seulement à l'acheteur d'origine du produit et est valide aux É.-U., incluant Alaska, Hawaii et ses possessions; et Canada.

<b><u>PÉRIODE DE GARANTIE:</u></b>  1an à partir de la date d'achat.	<b><u>POUR LE SERVICE:</u></b>  Téléphoner au 1-800-243-0000 (aux É.-U.) ou 1-888-LGCANADA appropriée. Avoir les numéros de modèle et de série, le type de produit et le code postal sous la main.
--	--

**CETTE GARANTIE EST EN LIEU DE TOUTE AUTRE GARANTIE, EXPLICITES OU IMPLICITES, INCLUANT SANS LIMITATION, TOUTE GARANTIE DE COMMERCIALISATION OU AUTRE POUR UN USAGE PARTICULIER. DANS L'ÉVENTUALITÉ OÙ UNE GARANTIE IMPLICITE EST REQUISE PAR LA LOI, ELLE EST LIMITÉE À LA DURÉE DE LA GARANTIE EXPLICITE CI-DESSUS. LG NE SERA PAS TENUE RESPONSABLE DES DOMMAGES ACCESSOIRES DIRECTS OU INDIRECTS DE TOUTE SORTE, INCLUANT LA PERTE DE REVENUS OU DE PROFITS, EN RAPPORT AVEC CE PRODUIT. CERTAINS ÉTATS NE PERMETTENT PAS LA LIMITATION SUR LA DURÉE D'UNE GARANTIE IMPLICITE ET L'EXCLUSION DE DOMMAGES ACCESSOIRES DIRECTS OU INDIRECTS, PAR CONSÉQUENT LES LIMITATIONS ET EXCLUSIONS SUSMENTIONNÉES PEUVENT NE PAS S'APPLIQUER.**

### **CETTE GARANTIE LIMITÉE NE S'APPLIQUE PAS:**

1. Les déplacements de service à domicile pour livrer, cueillir et/ou installer le produit, donner les instructions ou remplacer un fusible ou un câblage approprié ou corriger des réparations non autorisées, et;
2. Les dommages ou problèmes de fonctionnement résultant d'un mauvais usage, abus, fonctionnement hors des données techniques environnementales ou contraires aux exigences ou aux précautions du guide de fonctionnement, accident, vermine, incendie, inondation, installation inadéquate, actes de Dieu, modification non autorisée, tension ou courant électrique inadéquat, utilisation commerciale ou toute autre utilisation non prévue.
3. Par conséquent, les coûts de réparation ou de remplacement pour un produit défectueux relèvent de la responsabilité du consommateur.

### **NUMÉROS INTERACTIFS POUR CLIENTS:**

<b>Pour preuve de couverture de la garantie</b>	<b>Conserver la facture comme preuve de la date d'achat.</b> Un exemplaire de la facture doit être présenté au moment du service sous garantie.
<b>Pour obtenir un centre de service autorisé, un marchand ou obtenir de l'aide pour les produits, le service ou le service à la clientèle.</b>	<b>Téléphoner au 1-800-243-0000 ou 1-888-LGCANADA</b> et choisir l'option appropriée du menu. Avoir sous la main les numéros de modèle et de série, le type de produit et le code postal, ou visiter notre site web: <a href="http://www.lgservice.com">http://www.lgservice.com</a>

# IMPORTANTE: Lea y siga estas instrucciones.

## NOTA

Quien vaya a instalar debe tener entrenamiento en electricidad, y mecánica también conocimiento aceptable en el oficio.

La seguridad es primero --- tanto la suya como la de los otros son muy importantes. Se han previsto muchos mensajes de seguridad importantes en estas instrucciones y en su aparato. Siempre lea y obedezca todos los mensajes de seguridad.

## ⚠ ADVERTENCIA

### Riesgo de Peso Excesivo

Pueden solicitar ayuda de dos o más personas para mover e instalar la lavadora, combo y secadora con los pedestales.

No permita a los niños jugar en el tambor.  
No se pare en el mango.

## NOTA

Un piso firme y sólido es más necesario para una Carga Frontal que para una Carga Superior. Si su piso es de madera o está en construcción, puede ser que necesite reforzarlo. Las Cargas Frontales tienen mayor revolución que las Cargas Superiores, causando más vibración. Si el piso no es sólido, su lavadora va a vibrar. Va a oír y sentir la vibración en toda su casa.

## NOTA

No se recomienda emplear un recogegotas. Podría ocasionar vibraciones por causa de una mala nivelación de la lavadora. Si debe usarse, preste especial atención durante su instalación y asegúrese de que se realiza correctamente.



## Accesorios incluidos



4 Soporte



dieciocho  
4x20 mm  
truss Tapite

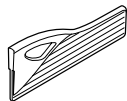

Séparateur de tiroir

## Herramientas necesarias



11/16 po o 17 mm  
Abrir llave de boca



Destornillador  
Phillips

## INSTALACION DE LA LAVADORA & COMBO

**1** Quite el pedestal, el disco duro de instalación e instrucciones del cartón de envío.

**2** Antes de instalar la lavadora, retire los objetos extraños del suelo y límpielo. La presencia de polvo, agua, aceite, detergentes, etc., podría producir vibraciones debido al mal contacto de las patas con el suelo.

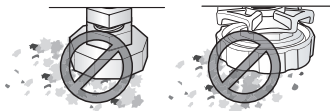

**3** Nivele el pedestal en un lugar limpio mediante el ajuste de sus patas.

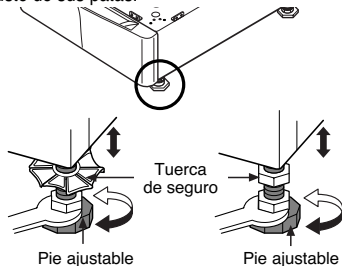

Pie ajustable

Pie ajustable

## NOTA

No extienda las patas niveladoras más de lo necesario. Mientras más extendidas estén, más vibración puede haber.

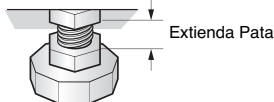

Extienda Pata

► Después de que la lavadora este nivelada, apretar la tuerca de seguro hacia la base de la lavadora. Asegurarse de que todas las tuercas estén apretadas.

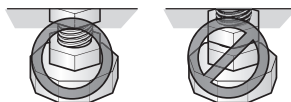

**4** Coloque la lavadora/combo encima del pedestal.

## NOTA

Debido al peso de la lavadora/combo, puede necesitar de dos o más personas.

## NOTA

Si la lavadora o combo fueron instalados previamente, desenchúfelo, desconecte la manguera de la entrada(s) del grifo(s), desconecte la manguera del desagüe, y desagüe todas las mangueras.

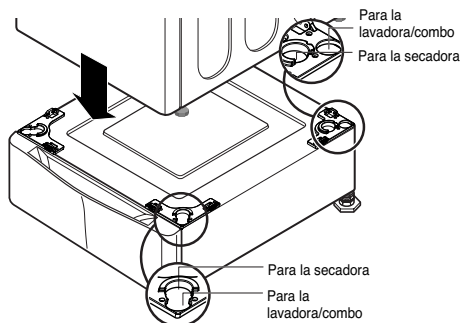

Para la  
lavadora/combo  
Para la secadora

Para la secadora  
Para la  
lavadora/combo

**5** Nivelación de la lavadora/combo sobre el pedestal se ajusta con la pata de la lavadora.

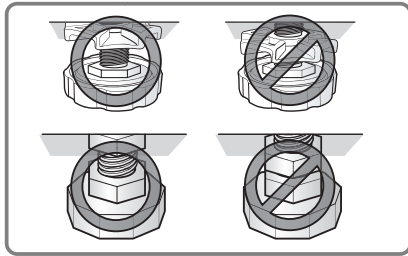
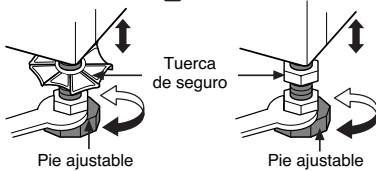
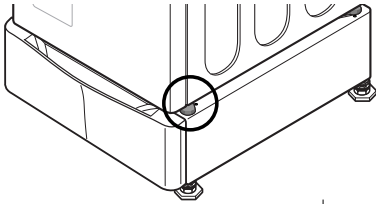

**6** Asegúrese de que los orificios del pedestal se alinean con los orificios del electrodoméstico, luego instale 4 tornillos en cada esquina para ajustar en forma segura el electrodoméstico al pedestal.

**NOTA**

si los tornillos no se instalan de manera adecuada, es posible que se produzcan ruidos y vibraciones. Mueva el electrodoméstico hacia la ubicación deseada.

Para la lavadora: 16 tornillos  
para la secadora : 8 tornillos

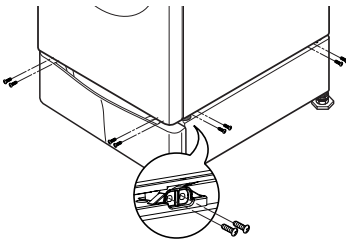

**7** Mover la lavadora/combo al lugar deseado.

**NOTA**

El aparato y el pedestal ensamblado deben ponerse sobre el suelo sólido y nivelado para un funcionamiento apropiado. Ajuste las patas del aparato y el pedestal dándole vueltas con la llave inglesa. Luego, ajuste el seguro de la cerradura hacia el pedestal mientras sostiene la pata del pedestal usando la llave inglesa.

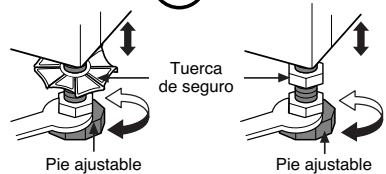
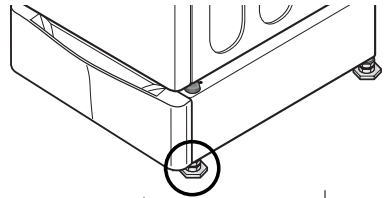

**NOTA**

**Verificación Diagonal**

Al empujar hacia abajo los extremos de la tapa superior de la lavadora de forma diagonal, esta no debe moverse hacia arriba y hacia abajo para nada (Verifíquelo en ambas direcciones).

Si la máquina se tambalea al empujar diagonalmente los extremos hacia abajo, ajuste las patas nuevamente.



**NOTA**

Es crítico que ajuste las patas correctamente. Esto debe hacerse mientras la lavadora esté girando **con una carga**. Inicie el lavado con una prueba de lavado para asegurarse que está bien nivelada.

Cargue aproximadamente 6 libras de ropa en la lavadora.

Luego presione **ENCENDIDO (POWER)**, **ENJUAGUE+GIRO (RINSE+SPIN)** e **INICIAR/PAUSA (START/PAUSE)**, en ese orden.

Cuando la lavadora esté girando a su mayor velocidad verifique si está estable.

Si no, ajuste nuevamente las patas.

Use la llave (abastecida) para ajustar las patas hasta que no haya vibración. Luego asegure los tornillos para evitar cambios en el nuevo ajuste.



## INSTALACION DE LA SECADORA

- 1 Quite el pedestal, instalación del disco duro e instrucciones del cartón del envío.
- 2 Insert the T-clip of the 4 retainers into the dryer base as shown. Press up on the back of the clip and pull outward to lock into place.

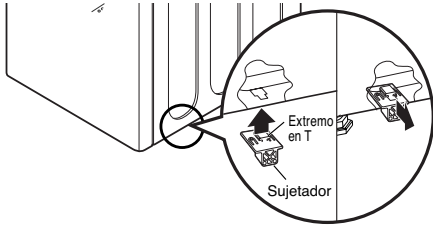

- 3 Coloque la secadora encima del pedestal.

### NOTA

Debido al peso de la secadora, pueden necesitarse dos o más personas.

### NOTA

Si la secadora fuera instalada previamente, desinstalela como sigue:

#### A. Desinstalando la secadora eléctrica:

- 1) Desenchufe el cordón de suministro de energía.
- 2) Jale la secadora fuera de la pared lo suficiente para aflojar la abrazadera del conducto de ventilación. Suelte la abrazadera y quite cuidadosamente el extractor del conducto de ventilación del enchufe del extractor de la secadora.

#### B. Desinstale la secadora de gas:

- 1) Quite el cordón de suministro de energía.
- 2) Apague el suministro de gas.
- 3) Jale la secadora fuera de la pared lo suficiente para aflojar la abrazadera del ventilación. Suelte la abrazadera y cuidadosamente quite el extractor de ventilación del enchufe del extractor de la secadora.

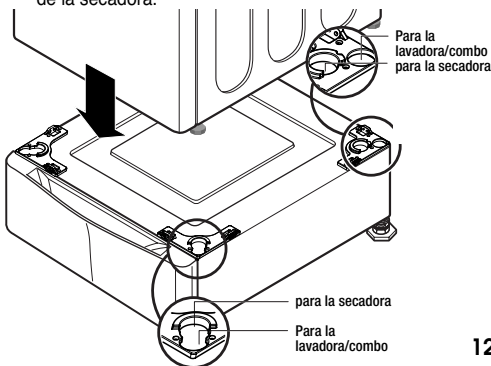

- 4 Asegúrese de que los orificios del pedestal se alinean con los orificios del electrodoméstico, luego instale 2 tornillos en cada esquina para ajustar en forma segura el electrodoméstico al pedestal.

### NOTA

si los tornillos no se instalan de manera adecuada, es posible que se produzcan ruidos y vibraciones.

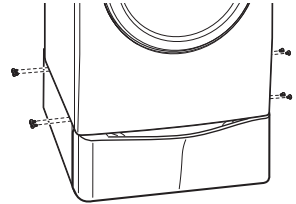

- 5 Mover la secadora al lugar deseado.

### NOTA

El aparato y el pedestal ensamblado deben ponerse sobre suelo sólido y nivelado para un funcionamiento apropiado. Ajuste las patas del aparato y el pedestal dando vueltas con la llave inglesa. Entonces, ajuste el seguro de la cerradura hacia el pedestal mientras sostiene la pata del pedestal usando la llave inglesa.

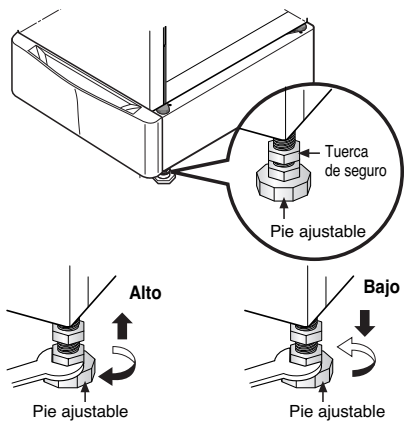

# GARANTÍA

**LG Electronics Inc.**, reparará o en defecto repondrá, sin cargo alguno, su producto si prueba ser defectuoso en material o mano de obra dentro de un uso normal durante el período establecido en la parte inferior de la garantía, efectivo desde el día de compra del producto. Esta garantía limitada es efectiva únicamente para el comprador original del producto, y efectivo únicamente si ha sido usado en los Estados Unidos, incluyendo Alaska, Hawaii y territorio norteamericano; y Canadá.

<p><b><u>PERIODO DE GARANTÍA:</u></b></p> <p>1 año desde la fecha de compra</p>	<p><b><u>COMO SE MANEJA EL SERVICIO:</u></b></p> <p>Llame al 1-800-243-0000 (los Estados Unidos) o 1-888-LGCANADA</p>
---	---

**ESTA GARANTÍA REEMPLAZA CUALQUIER OTRA GARANTÍA, EXPRESA O IMPLÍCITA, INCLUYENDO SIN LIMITACIÓN CUALQUIER GARANTÍA DE VENTA DE MERCANCÍA O CONVENIENCIA PARA PROPÓSITOS PARTICULARES, EN EL EXTENDIDO CUALQUIER GARANTÍA IMPLÍCITA ES REQUERIDA POR LEY, ES LIMITADA EN DURACIÓN AL PERÍODO DE GARANTÍA EXPRESA EN LA PARTE INFERIOR. LG NO SE HARÁ RESPONSABLE POR CUALQUIER DAÑO INDIRECTO, CONSECUENTE O INCIDENTAL DE NINGÚN TIPO, INCLUYENDO PÉRDIDAS DE INGRESOS O GANANCIAS, EN RELACIÓN CON EL PRODUCTO. ALGUNOS ESTADOS NO PERMITEN LÍMITES EN CUANTO A LA DURACIÓN DE LA GARANTÍA IMPLÍCITA, O LA EXCLUSIÓN DE DAÑOS INCIDENTALES O DAÑOS CONSECUENTES, ASÍ QUE LO CITADO EN LA PARTE INFERIOR PUEDE NO APLICARSE A USTED.**

## ESTA GARANTÍA LIMITADA NO APLICA A:

1. Viajes de servicio a su casa para llevar, recoger y/o instalar el producto, instruir o reponer fusibles o conectar correctamente cables, o la corrección de piezas desautorizadas; y
2. Daños o problemas operacionales como resultado de un mal uso, abuso, operación dentro de un ambiente no especificado o contrario a los requerimientos o precauciones en la Guía Operacional, accidentes, plagas, incendios, inundaciones, instalación inapropiada, actos de Dios, alteraciones o modificaciones desautorizadas, voltaje incorrecto, uso comercial, o para el uso de otros fines que no sean los propósitos intencionados.
3. Consecuentemente, el costo de las reparaciones o reemplazo del producto defectuoso, será asumido por el consumidor.

## MÚMEROS CENTRALES INTERACTIVOS PARA EL CLENTE:

<p><b>Para comprobar la cobertura de la garantía:</b></p>	<p><b>Conserve su recibo para comprobar la fecha de compra. Una copia de su recibo será requerida en el momento en el que el servicio de la garantía es proveído.</b></p>
<p><b>Para obtener Centros de Servicio Autorizados cercanos, o para obtener producto, o asistencia de servicio o para el consumidor:</b></p>	<p>Llame al 1-800-243-0000 o 1-888-LGCANADA y escoja la opción del menú apropiada y tenga a la mano su tipo de producto, número de modelo, número de serie y código postal; o visite nuestra página de internet en <a href="http://www.lgservice.com">http://www.lgservice.com</a></p>

● **MODEL : 27" LWP-277\* / WDP4\***

Net weight : 52.9 lb (24 kg)

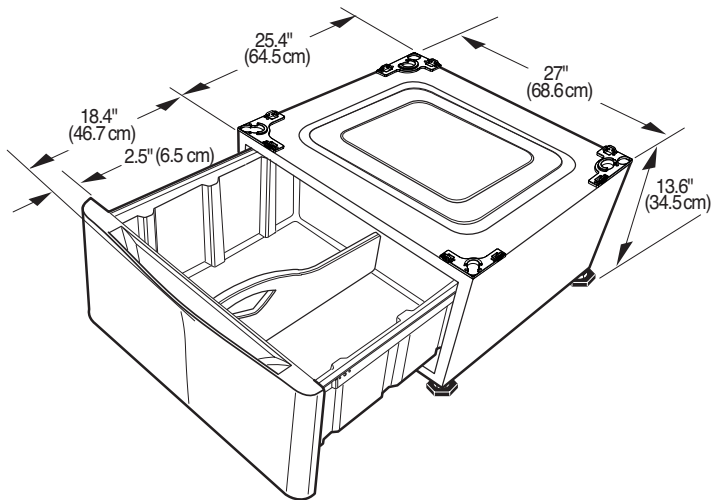

● **MODEL : 29" LWP-290\* / WDP5\***

Net weight : 57.3 lb (26 kg)

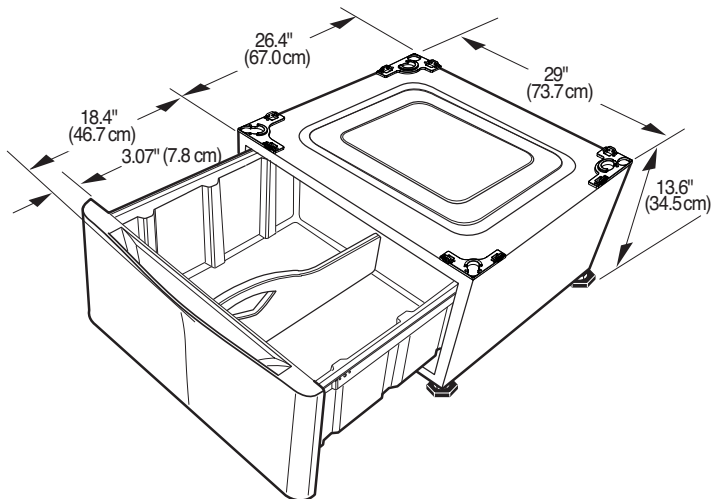

※ Specifications are subject to change by manufacturer.

※ Las especificaciones son sujetas a cambio por el fabricante

※ Données techniques sujettes à changement sans préavis



**MEMO**

