



OWNER'S MANUAL

DRYER

Read this owner's manual thoroughly before operating the appliance and keep it handy for reference at all times.

ENGLISH ESPAÑOL

DLE3600*, DLG3601*
DLEX4000*, DLGX4001*
DLEX4200*, DLGX4201*
DLEX4500*, DLGX4501*



MFL70442647
Rev.03_070620

www.lg.com

Copyright © 2020 LG Electronics Inc. All Rights Reserved.

TABLE OF CONTENTS

3 PRODUCT FEATURES

4 SAFETY INSTRUCTIONS

5 IMPORTANT SAFETY INSTRUCTIONS

9 PRODUCT OVERVIEW

9 Parts

9 Accessories

10 INSTALLATION

10 Installation Overview

10 Product Specifications

11 Installation Location Requirements

12 Clearances

14 Leveling the Dryer

15 Reversing the Door

16 Installing the Side Vent Kit

17 Stacking the Dryer

18 Venting the Dryer

20 Connecting the Inlet Hose
(Steam Models)

21 Connecting Gas Dryers

23 Connecting Electric Dryers

28 Special Electrical Requirements

28 Final Installation Check

29 Installation Test (Duct Check)

31 OPERATION

31 Using the Dryer

32 Check the Lint Filter Before Every Load

32 Sorting Laundry

32 Loading the Dryer

33 Control Panel

36 Cycle Guide

40 Cycle Modifier Buttons

40 Option Buttons

41 Special Functions

41 Steam Functions
(Steam Models)

44 SMART FUNCTIONS

44 LG ThinQ Application

47 Smart Diagnosis™ Function

48 MAINTENANCE

48 Regular Cleaning

49 TROUBLESHOOTING

49 FAQs: Frequently Asked Questions

49 User Support Videos

50 Before Calling for Service

56 WARRANTY

PRODUCT FEATURES

Easy-to-Use Control Panel

Rotate the cycle selector knob to select the desired dry cycle. Add cycle options or adjust settings with the touch of a button.

Easy-Access Reversible Door

The wide-opening door provides easy access for loading and unloading. The door hinge can be reversed to adjust for installation location.

Steam Functions (Steam Models)

LG's steam technology allows you to inject fabrics with a swirling jet of hot steam to refresh clothes, reduce static, and make ironing easier. Simply select the Steam Fresh™ cycle, or you can add a Steam option to selected cycles.

Flow Sense™ Duct Blockage Sensing System Indicator

The Flow Sense™ duct blockage sensing system detects and alerts you to restrictions in the installed household ductwork that reduce exhaust airflow through the dryer. If you see the alert: Clean or repair the ducts to remove the restrictions. Keep your ducts clean to help increase efficiency and reduce long drying times caused by blocked ducts.

Smart Diagnosis™

Should you experience any technical difficulty with your dryer, it has the capability of transmitting data via your telephone to the Customer Information Center. The call center agent records the data transmitted from your machine and uses it to analyze the issue, providing a fast and effective diagnosis.

LG ThinQ

Download the new LG smart phone app to set options, self-diagnose and troubleshoot problems with the appliance, and other useful features. This function uses Wi-Fi.



SAFETY INSTRUCTIONS

READ ALL INSTRUCTIONS BEFORE USE

Your safety and the safety of others are very important.

We have provided many important safety messages in this manual and on your appliance. Always read and follow all safety messages.

This is the safety alert symbol.



This symbol alerts you to potential hazards that can kill or injure you and others.

All safety messages will follow the safety alert symbol and either the word WARNING or CAUTION.

These words mean:



WARNING

You may be killed or seriously injured if you do not follow instructions.



CAUTION

You may be slightly injured or cause damage to the product if you do not follow instructions.

All safety messages will tell you what the potential hazard is, tell you how to reduce the chance of injury, and tell you what may happen if the instructions are not followed.

WARNING- Risk of Fire

Install the clothes dryer according to the manufacturer's instructions and local codes.

- Clothes dryer installation must be performed by a qualified installer.
- Do not install a clothes dryer with flexible plastic venting materials. If flexible metal (foil type) duct is installed, it must be of a specific type identified by the appliance manufacturer as suitable for use with clothes dryers. Flexible venting materials are known to collapse, be easily crushed, and trap lint. These conditions will obstruct clothes dryer airflow and increase the risk of fire.
- To reduce the risk of severe injury or death, follow all installation instructions.
- Save these instructions.



WARNING

FIRE OR EXPLOSION HAZARD

Failure to follow safety warnings exactly could result in serious injury, death or property damage.

- Do not store or use gasoline or other flammable vapors and liquids in the vicinity of this or any other appliance.
- WHAT TO DO IF YOU SMELL GAS
 - Do not try to light any appliance.
 - Do not touch any electrical switch; do not use any phone in your building.
 - Clear the room, building or area of all occupants.
 - Immediately call your gas supplier from a neighbor's phone. Follow the gas supplier's instructions.
 - If you cannot reach your gas supplier, call the fire department.
- Installation and service must be performed by a qualified installer, service agency or your gas supplier.

IMPORTANT SAFETY INSTRUCTIONS

WARNING

To reduce the risk of explosion, fire, death, electric shock, scalding or injury to persons when using this product, follow basic precautions, including the following:

INSTALLATION

- Before use, the appliance must be properly installed as described in this manual.
- Connect to a properly rated, protected, and sized power circuit to avoid electrical overload.
- To reduce the risk of severe injury or death, follow all installation instructions.
- The appliance must be installed and electrically grounded by qualified service personnel in accordance with local codes.
- Disconnect the power cord, house fuse or circuit breaker before installing or servicing the appliance.
- When moving or installing the product in a different location, call qualified service personnel for installation and service.
- Keep packing materials out of the reach of children. Packaging material can be dangerous for children. There is a risk of suffocation.
- Moving or installation of the appliance requires two or more people.
- This appliance is not designed for maritime use or for mobile installations such as in RVs, trailers, or aircraft.
- Store and install the appliance where it will not be exposed to temperatures below freezing or exposed to outdoor weather conditions.
- This appliance must be positioned near to an electrical power supply.
- Do not, under any circumstances, cut or remove the third (ground) prong from the power cord.
- When installing or moving the appliance, be careful not to pinch, crush, or damage the power cord.
- Do not install the appliance in humid spaces.
- Destroy the carton, plastic bag, and other packing materials after the appliance is unpacked. Children might use them for play. Cartons covered with rugs, bedspreads, or plastic sheets can become airtight chambers.
- Adhere to all industry recommended safety procedures including the use of long sleeved gloves and safety glasses.
- Never attempt to operate this appliance if it is damaged, malfunctioning, partially disassembled, or has missing or broken parts, including a damaged cord or plug.
- Do not install a clothes dryer with flexible plastic venting materials. If flexible metal (foil type) duct is installed, it must be of a specific type identified by the appliance manufacturer as suitable for use with clothes dryers. Flexible venting materials are known to collapse, be easily crushed, and trap lint. These conditions will obstruct clothes dryer airflow and increase the risk of fire.

- Place the dryer at least 18 inches above the floor for a garage installation.
- Do not use sheet metal screws or other fasteners which extend into the duct that could catch lint and reduce the efficiency of the exhaust system. Secure all joints with duct tape.
- Use only rigid, semi-rigid or flexible metal 4-inch diameter duct inside the dryer cabinet or for exhausting to the outside. Use of plastic or other combustible ductwork may cause a fire. Punctured ductwork may cause a fire if it collapses or becomes otherwise restricted in use or during installation.
- The exhaust duct must be 4 inches (10.2 cm) in diameter with no obstructions. The exhaust duct should be kept as short as possible. Make sure to clean any old ducts before installing your new dryer.
- Rigid, semi-rigid or flexible metal ducting is recommended for use between the dryer and the wall. All non-rigid metal transition duct must be UL-listed. Use of other materials for transition duct could affect drying time.
- Ductwork is not provided with the dryer, and you should obtain the necessary ductwork locally. The end cap should have hinged dampers to prevent backdraft when the dryer is not in use.
- Gas dryers **MUST** be exhausted to the outside.
- The dryer exhaust system must be exhausted to the outside of the dwelling. If the dryer is not exhausted outdoors, some fine lint and large amounts of moisture will be expelled into the laundry area. An accumulation of lint in any area of the home may create a health and fire hazard.
- Do not install near another heat source such as a stove, oven or heater.
- Keep area around the exhaust opening and adjacent surrounding areas free from the accumulation of lint, dust, and dirt.
- The appliance must not be supplied through an external switching device, such as a timer, or connected to a circuit that is regularly switched on and off by a utility.

OPERATION

- Repair or immediately replace all power cords that have become frayed or otherwise damaged. Do not use a cord that shows cracks or abrasion damage along its length or at either end.
- If you detect a strange sound, a chemical or burning smell, or smoke coming from the appliance, unplug it immediately, and contact an LG Electronics customer information center.
- Never unplug the appliance by pulling on the power cord. Always grip the plug firmly and pull straight out from the outlet.
- Do not use an extension cord or adapter with this appliance.
- Do not grasp the power cord or touch the appliance controls with wet hands.
- Do not modify or extend the power cord.
- If the product has been submerged, contact an LG Electronics customer information center for instructions before resuming use.
- Do not store or use gasoline or other flammable vapors and liquids in the vicinity of this or any other appliance.
- Keep the area underneath and around your appliances free of combustible materials (lint, paper, rags, etc.), gasoline, chemicals and other flammable vapors and liquids.
- This appliance is not intended for use by persons (including children) with reduced physical, sensory or mental capabilities, or lack of experience and knowledge, unless they have been given supervision or instruction concerning the use of the appliance by a person responsible for their safety.

- Read all instructions before using the appliance and save these instructions.
- Use this appliance only for its intended purpose.
- Do not abuse, sit on, or stand on the door of the appliance.
- Do not allow children to play on, in or with the appliance. Close supervision of children is necessary when the appliance is used near children.
- Do not tamper with controls.
- In the event of a gas leak (propane gas, LP gas, etc.) do not operate this or any other appliance. Open a window or door to ventilate the area immediately.
- Under certain conditions, hydrogen gas may be produced in a hot-water system that has not been used for two weeks or more. **HYDROGEN GAS IS EXPLOSIVE.** If the hot-water system has not been used for such a period, before using the appliance turn on all hot water faucets and let the water flow from each for several minutes. This will release any accumulated hydrogen gas. As the gas is flammable, do not smoke or use an open flame during this time.
- Fix the drain hose securely in place.
- Do not put oily or greasy clothing, candles or flammable materials on top of the appliance.
- Do not use fabric softeners or products to eliminate static unless recommended by the manufacturer of the fabric softener or product.
- Do not reach into the appliance if the drum is moving.
- Do not dry articles that have been previously cleaned in, washed in, soaked in, soiled with or spotted with gasoline, dry cleaning solvents, vegetable oil, cooking oil or other flammable or explosive substances, as they give off vapors that could ignite or explode.
- Do not use heat to dry articles containing foam rubber or similarly textured rubber-like materials.
- Do not store plastic, paper, or clothing that may burn or melt on top of the dryer during operation.
- Always check the inside of the appliance for foreign objects.
- Gas appliances can cause minor exposure to four potentially hazardous substances, namely benzene, carbon monoxide, formaldehyde, and soot, caused primarily by the incomplete combustion of natural gas or LP fuels.
- Properly adjusted dryers will minimize incomplete combustion. Exposure to these substances can be minimized further by properly venting the dryer to the outdoors.
- Do not place items exposed to cooking oils in your dryer. Items contaminated with cooking oils may contribute to a chemical reaction that could cause a load to catch fire.
To reduce the risk of fire due to contaminated loads, the final part of a tumble dryer cycle occurs without heat (cool down period). Avoid stopping a tumble dryer before the end of the drying cycle unless all items are quickly removed and spread out so that the heat is dissipated.
- Do not let children or pets climb inside the dryer drum.
- Do not put living animals such as pets inside the product.
- Do not put any part of your body, such as your hands or feet, or metal objects under the product.
- Do not let your hand get pinched when opening or closing the dryer door.

STEAM (Steam Models)

- Do not open the dryer door during steam cycles.
- Do not touch the steam nozzle in the drum during or after a steam cycle.

MAINTENANCE

- Do not repair or replace any part of the appliance. All repairs and servicing must be performed by qualified service personnel unless specifically recommended in this Owner's Manual. Use only authorized factory parts.
- Do not disassemble or repair the appliance by yourself.
- Remove any dust or foreign matter from the power plug pins.
- Disconnect this appliance from the power supply before cleaning and attempting any user maintenance. Turning the controls to the OFF position does not disconnect this appliance from the power supply.
- Remove the door before the appliance is removed from service or discarded to avoid the danger of children or small animals getting trapped inside.
- Unplug the appliance before cleaning to avoid the risk of electric shock.
- Clean the lint filter before or after each load.
- The interior of the appliance and exhaust duct should be cleaned periodically by qualified service personnel.

GROUNDING INSTRUCTIONS

- Improper connection of the equipment-grounding conductor can result in a risk of electric shock. Check with a qualified electrician or service personnel if you are in doubt whether the appliance is properly grounded. Do not modify the plug provided with the appliance; if it will not fit the outlet, have a proper outlet installed by a qualified electrician.
- The appliance must be grounded. In the event of a malfunction or breakdown, grounding will reduce the risk of electric shock by providing a path of least resistance for electric current. The appliance is equipped with a cord having an equipment-grounding conductor and a grounding plug. The plug must be plugged into an appropriate outlet that is installed and grounded in accordance with all local codes and ordinances.
- This dryer must be plugged into a properly grounded outlet. Electrical shock may result if the dryer is not properly grounded. Have the wall outlet and circuit checked by a qualified electrician to make sure the outlet is properly grounded. Failure to follow these instructions may create an electric shock hazard and/or a fire hazard.

WARNING

Fire Hazard

Failure to follow safety warnings exactly could result in serious injury, death or property damage.

- Do not install a booster fan in the exhaust duct.
- Install all clothes dryers in accordance with the installation instructions of the manufacturer of the dryer.

SAVE THESE INSTRUCTIONS

PRODUCT OVERVIEW

Parts

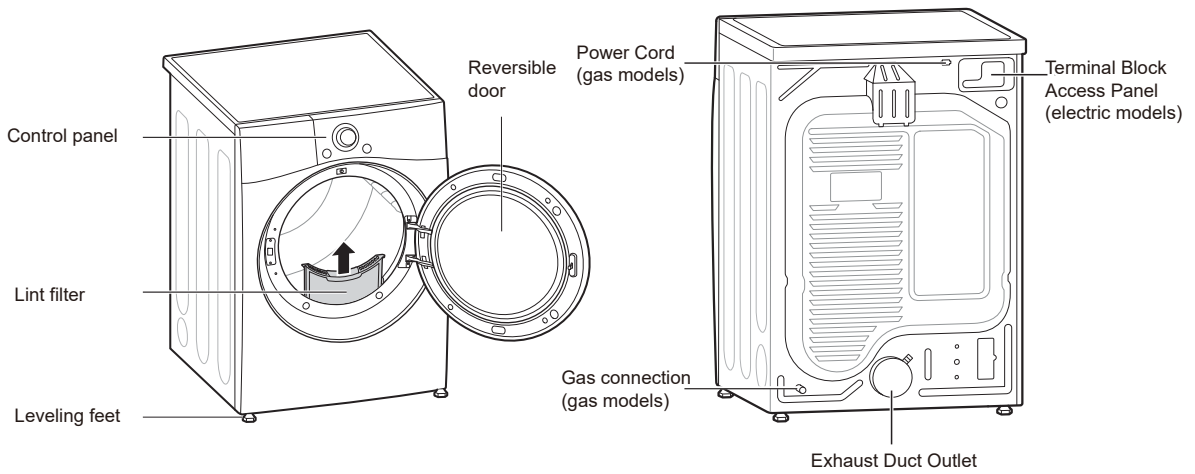

Accessories

Included Accessories



Y connector
(Steam Models)

Optional Accessories

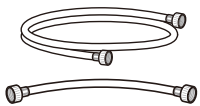

Hoses
(Steam Models)

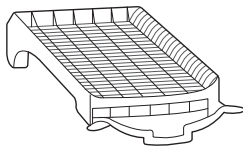

Drying Rack
(sold separately)

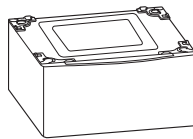

Pedestal
(sold separately)



Stacking kit
(sold separately)

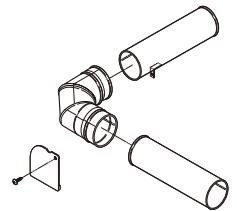

Side vent kit
(sold separately)
Kit No. 383EEL9001B

NOTE

- For your safety and extended product life, use only authorized components. The manufacturer is not responsible for product malfunction or accidents caused by the use of unauthorized components or parts.
- The images in this manual may be different from the actual components and accessories which are subject to change by the manufacturer without prior notice for product improvement purposes.

INSTALLATION

Installation Overview

Please read the following installation instructions first after purchasing this product or transporting it to another location.

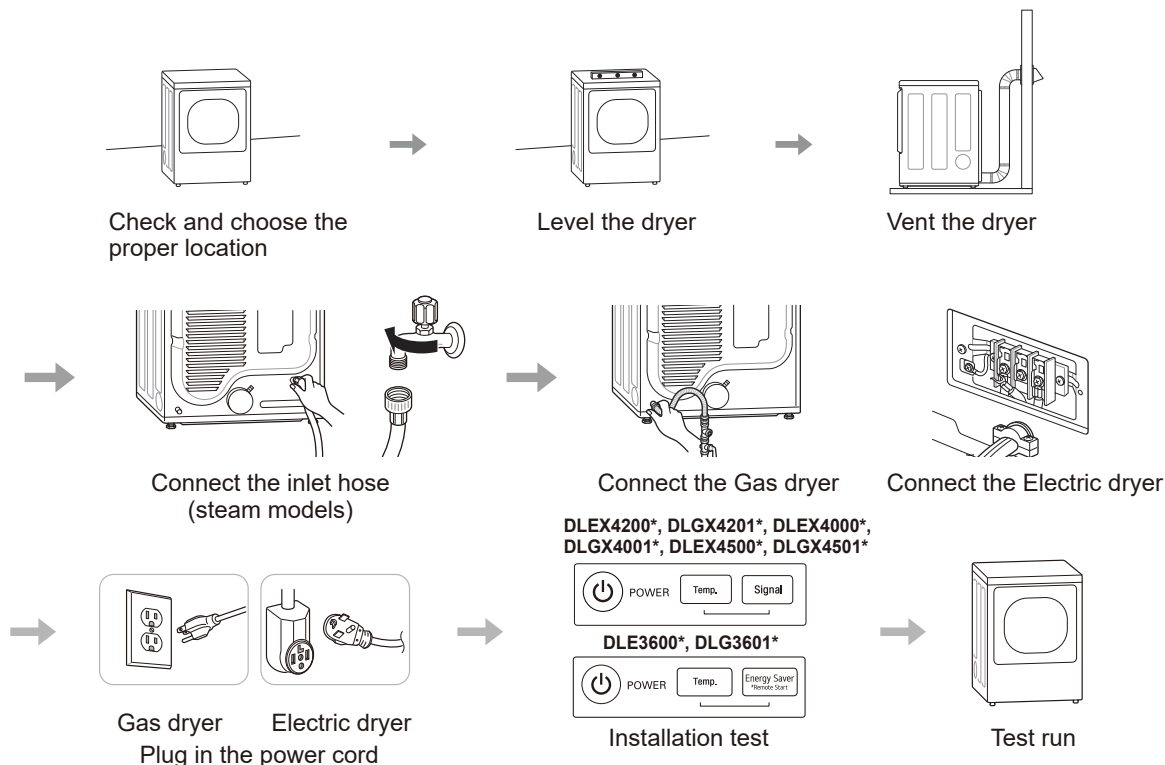

Product Specifications

The appearance and specifications listed in this manual may vary due to constant product improvements.

Dryer Models		DLE3600*, DLG3601*	DLEX4000*, DLGX4001*	DLEX4200*, DLGX4201*	DLEX4500*, DLGX4501*
Description		Non-steam Dryer	Steam Dryer	Steam Dryer	
Electrical requirements		Please refer to the rating label for detailed information.			
Gas requirements		NG: 4 - 10.5-inch (10.2 - 26.7 cm) WC LP: 8 - 13-inch (20.4 - 33.1 cm) WC			
Dimensions		27" (W) X 30 1/8" (D) X 39" (H), 51 3/8" (D with door open) 68.6 cm (W) X 76.5 cm (D) X 99 cm (H), 130.5 cm (D with door open)		27" (W) X 30" (D) X 39" (H), 51" (D with door open) 68.6 cm (W) X 76.1 cm (D) X 99 cm (H), 129.7 cm (D with door open)	
Net weight		Gas : 136.03 lb (61.7kg) - 139.34 lb (63.2kg) Electric : 121.9 lb (55.3kg) - 125.3 lb (56.8kg)		Gas : 140.4 lb (63.7 kg) Electric : 133.4 lb (60.5 kg)	
Drying capacity	Steam Cycle	-	IEC 7.4 cu.ft. (8 lb/3.6 kg)		
	Normal Cycle	IEC 7.4 cu.ft. (22.5 lb/10.2 kg)			

NOTE

Model numbers can be found on the cabinet inside the door.

Installation Location Requirements

WARNING

- Read all installation instructions completely before installing and operating your dryer. It is important that you review this entire manual before installing and using your dryer. Detailed instructions concerning electrical connections, gas connections, and exhaust requirements are provided on the following pages.

WARNING

To reduce the risk of serious injury or death, follow basic precautions, including the following:

- Use long-sleeved gloves and safety glasses.
- The appliance is heavy. Two or more people are required when installing the dryer.

The installation requires:

- A location that allows for proper exhaust installation. A gas dryer must be exhausted to the outdoors. See Venting the Dryer.
- A grounded electrical outlet located within 2 ft. (61 cm) of either side of the dryer. See Connecting Electric Dryers.
- A sturdy floor to support the total dryer weight of 200 lb (90.7 kg). The combined weight of a companion appliance should also be considered.
- No other fuel-burning appliance can be installed in the same closet as a dryer.
- Additional clearances might be required for wall, door and floor moldings.
- Companion appliance spacing should also be considered.

NOTE

- The floor must be level, with a maximum slope of 1 inch (2.5 cm) under the entire dryer. Clothes may not tumble properly, and automatic sensor cycles may not operate correctly if the dryer is not level.
- For garage installation, you will need to place the dryer at least 18 inches (45.7 cm) above the floor. The standard pedestal height is 15 inches (38 cm). You will need 18 inches (45.7 cm) from the garage floor to the bottom of the dryer.
- Do not operate your dryer at temperatures below 45 °F (7 °C). At lower temperatures, the dryer might not shut off at the end of an automatic cycle. This can result in longer drying times.
- The dryer must not be installed or stored in an area where it will be exposed to water and/or weather.
- Check code requirements that limit, or do not permit, installation of the dryer in garages, closets, mobile homes or sleeping quarters. Contact your local building inspector.

Clearances

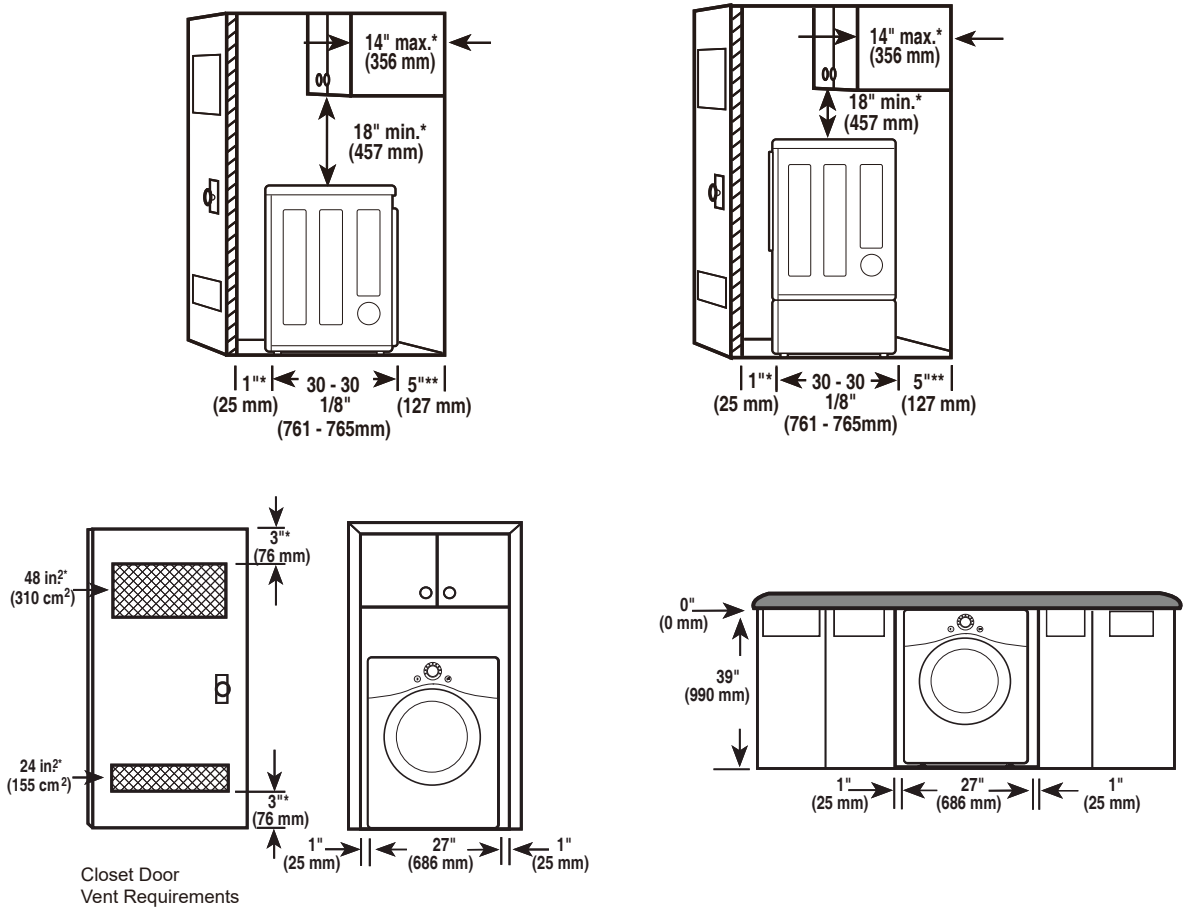

Installation Spacing for Recessed Area or Closet Installation

The following clearances are recommended for this dryer. This dryer has been tested for clearances of 1 inch (2.5 cm) on the sides and rear. Recommended clearances should be considered for the following reasons:

- Additional clearances should be considered for ease of installation and servicing.
- Additional clearances should be considered on all sides of the dryer to reduce noise transfer. For closet installation, with a door, minimum ventilation openings in the top and bottom of the door are required. Louvered doors with equivalent ventilation openings are acceptable.

Closet Ventilation Requirements

Closets with doors must have both an upper and lower vent to prevent heat and moisture buildup in the closet. One upper vent opening with a minimum opening of 48 sq. in. (310 cm²) must be installed no lower than 6 feet above the floor. One lower vent opening with a minimum opening of 24 sq. in. (155 cm²) must be installed no more than one foot above the floor. Install vent grilles in the door or cut down the door at the top and bottom to form openings. Louvered doors with equivalent ventilation openings are also acceptable.

NOTE

- There should be at least a little space around the dryer (or any other appliance) to eliminate the transfer of vibration from one appliance to another. If there is enough vibration, it could cause appliances to make noise or come into contact, causing paint damage and further increasing noise.

Installation Spacing for Recessed Area or Closet, with Stacked Washer and Dryer

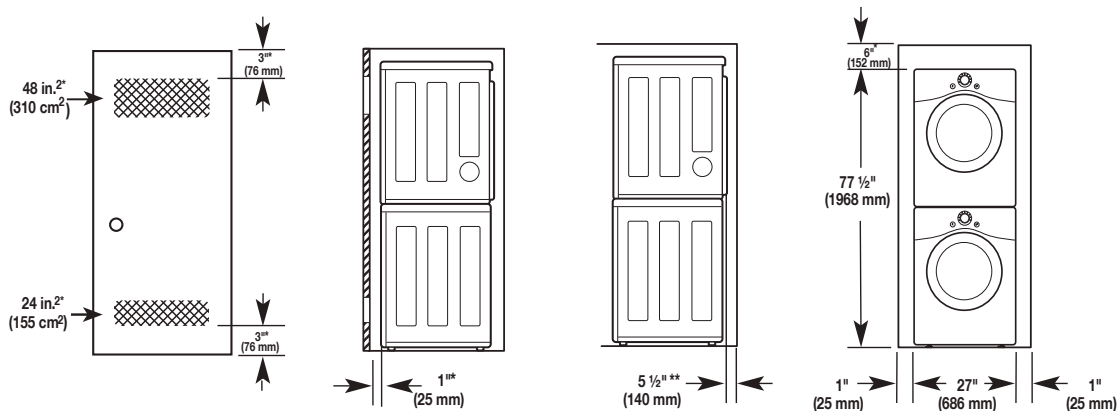

* Required spacing

** For side or bottom venting, 2-inch (5.1 cm) of spacing is allowed.

Installation Spacing for Cabinet

For cabinet installation with a door, minimum ventilation openings in the top of the cabinet are required.

* Required spacing

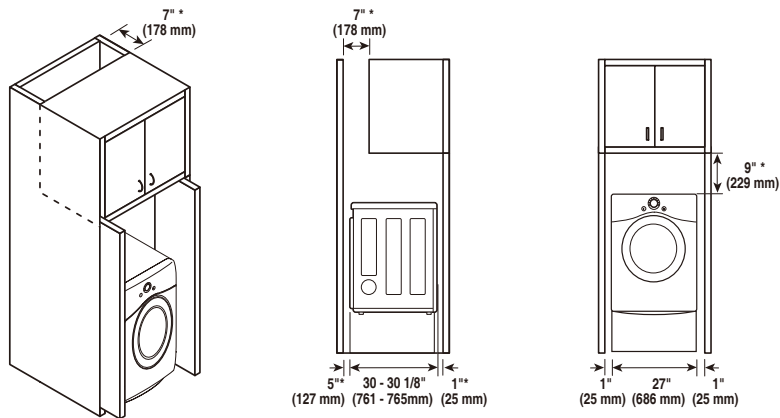

Leveling the Dryer

NOTE

- Adjust the leveling feet only as far as necessary to level the dryer. Extending the leveling feet more than necessary may cause the dryer to vibrate.
- To ensure that the dryer provides optimal drying performance, it must be level. To minimize vibration, noise, and unwanted movement, the floor must be a perfectly level, solid surface.

- 1 Position the dryer in the final location. Place a level across the top of the dryer.

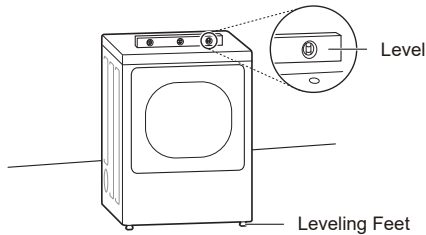

- All four leveling feet must rest solidly on the floor. Gently push on the top corners of the dryer to make sure that the dryer does not rock from corner to corner.

NOTE

- If you are installing the dryer on the optional pedestal, you must use the leveling feet on the pedestal to level the dryer. The dryer leveling feet should be fully retracted.

- 2 Use an adjustable wrench to turn the leveling feet. Unscrew the legs to raise the dryer or screw in the legs to lower it. Adjust the leveling feet until the dryer is level from side to side and front to back. Make sure that all four leveling feet are in firm contact with the floor.

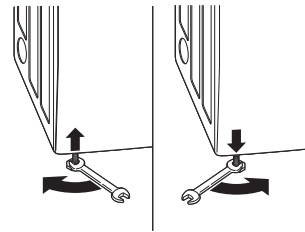

Reversing the Door

Tools Required

- Phillips screwdriver
- Large flat blade screwdriver (recommended for hinge screws if they are tight or your Phillips screwdriver is worn)
- Small flat blade screwdriver (for lifting out parts)

! WARNING

To reduce the risk of damage to the dryer, property damage or personal injury, follow basic precautions, including the following:

- Support the door with a stool or box that fits under the door, or have an assistant support the weight of the door.
- Avoid dropping the door.
- Unplug the dryer or turn off power at the main circuit breaker before beginning door reversal.
- Always reverse the door BEFORE stacking the dryer on top of the washer.

Door Reversal Instructions

The instructions here are for changing the door swing from a right to a left side hinge. If the door has been reversed, and it is necessary to change it back, use care when following these instructions. Some of the illustrations and the left/right references will be reversed, and you will need to read the instructions carefully.

! WARNING

- Be sure to support the weight of the door before removing the hinge screws.

- 1 Open the door and remove the two decorative screws, two latch screws, and the latch on the catch side with a screwdriver. Save these for step 4.

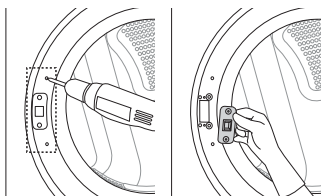

- 2 While supporting the door, remove the 2 screws on the door hinge. Remove the door.

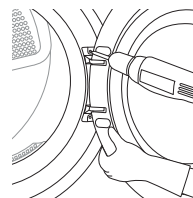

- 3 Turn the door upside down and line up the holes in the hinge with the holes on the opposite side of the cabinet. Reinstall the door with the screws removed in step 2.

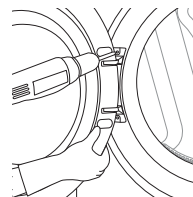

! WARNING

- Be sure to support the weight of the door before installing the hinge screws.

- 4 Install the two decorative screws, the latch, and two latch screws removed in step 1 on the opposite side from which they were removed.

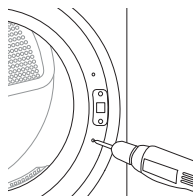

- 5 Check that the door closes properly.

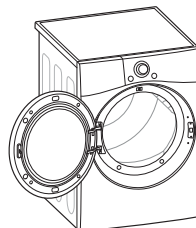

Installing the Side Vent Kit

⚠ WARNING

To reduce the risk of serious injury, death or property damage, follow basic precautions, including the following:

- Use long-sleeved gloves and safety glasses.
- Use a heavy metal vent.
- Do not use plastic or thin foil ducts.
- Clean old ducts before installing this dryer.

Your new dryer is configured to vent to the rear. It can also vent to the bottom or side (right-side venting is not available on gas models).

An adapter kit, part number 383EEL9001B, may be purchased from your LG retailer. This kit contains duct components necessary to change the dryer vent location.

- 1 Remove the rear exhaust duct retaining screw. Pull out the exhaust duct.

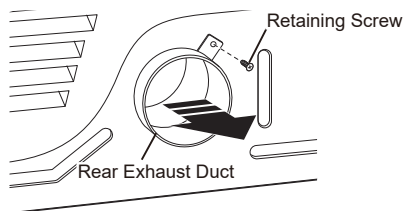

Option 1: Side Venting

- 2 Press the tabs on the knockout and carefully remove the knockout for the desired vent opening (right-side venting is not available on gas models). Press the adapter duct onto the blower housing and secure to the base of the dryer as shown.

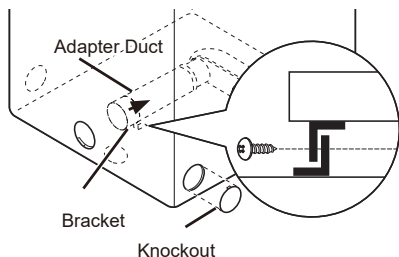

- 3 Preassemble a 4-inch (10.2 cm) elbow to the next 4-inch (10.2 cm) duct section, and secure all joints with duct tape. Be sure that the male end of the elbow faces AWAY from the dryer. Insert the elbow/duct assembly through the side opening and press it onto the adapter duct. Secure it in place with duct tape. Be sure that the male end of the duct protrudes 1.5 inches (3.8 cm) to connect the remaining ductwork. Attach the cover plate to the back of the dryer with the included screw.

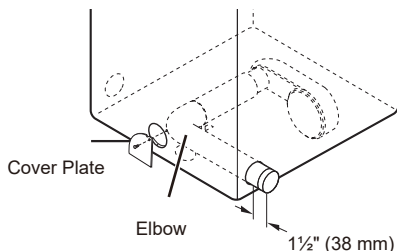

Option 2: Bottom Venting

- 2 Press the adapter duct onto the blower housing and secure it to the base of the dryer as shown.

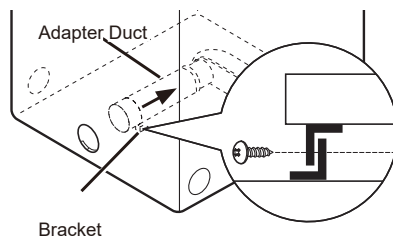

- 3 Insert the 4-inch (10.2 cm) elbow through the rear opening and press it onto the adapter duct. Be sure that the male end of the elbow faces down through the hole in the bottom of the dryer. Secure it in place with duct tape. Attach the cover plate to the back of the dryer with the included screw.

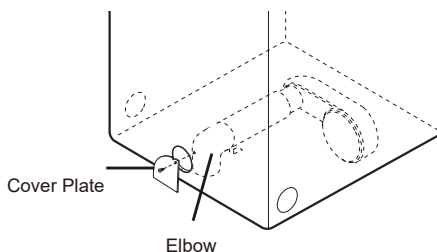

Stacking the Dryer

Stacking Kit Installation

This stacking kit includes:

- Two (2) side rails
- One (1) front rail
- Four (4) screws

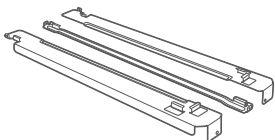

Tools Needed for Installation:

- Phillips screwdriver



! WARNING

To reduce the risk of electrical shock, fire, explosion, property damage, serious injury or death, follow basic precautions, including the following:

- The weight of the dryer and the height of installation make this stacking procedure too risky for one person. Two or more people are required when installing the stacking kit.
- Do not use the stacking kit with a gas dryer in potentially unstable conditions such as a mobile home.
- Place the washer on a solid, stable, level floor capable of supporting the weight of both appliances.
- Do not stack the washer on top of the dryer.
- If appliances are already installed, disconnect them from all power, water, or gas lines and from draining or venting connections.

To ensure safe and secure installation, please observe the following instructions.

- 1 Make sure the surface of the washer is clean and dry. Remove paper backing from the tape on one of the stacking kit side brackets.

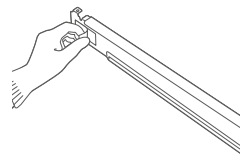

- 2 Fit the side bracket to the side of the washer top as shown in the below illustration. Firmly press the adhesive area of the bracket to the washer surface. Secure the side bracket to the washer with a screw on the back side of the bracket. Repeat steps 1 and 2 to attach the other side bracket.

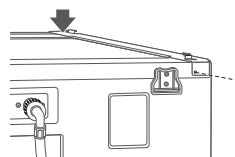

- 3 Place the dryer on top of the washer, fitting the dryer feet into the side brackets as illustrated. Avoid finger injuries; do not allow fingers to be pinched between the washer and dryer. Slowly slide the dryer toward the back of the washer until the side bracket stoppers catch the dryer feet.

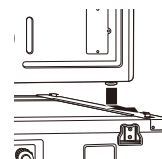

- 4 Insert the front rail between the bottom of the dryer and the top of the washer. Push the front rail toward the back of the washer until it comes in contact with the side rail stoppers. Install the two remaining screws to secure the front rail to the side rails.

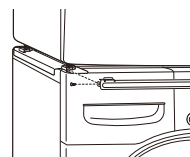

Venting the Dryer

WARNING



To reduce the risk of fire or explosion, electric shock, property damage, injury to persons or death when using this appliance, follow basic safety precautions, including the following:

- Do not crush or collapse ductwork.
- Do not allow ductwork to rest on or contact sharp objects.
- If connecting to existing ductwork, make sure it is suitable and clean before installing the dryer.
- Venting must conform to local building codes.
- Gas dryers **MUST** exhaust to the outdoors.
- Use only 4-inch (10.2 cm) rigid, semi-rigid or flexible metal ductwork inside the dryer cabinet and for venting outside.
- To reduce the risk of fire, combustion, or accumulation of combustible gases, **DO NOT** exhaust dryer air into an enclosed and unventilated area, such as an attic, wall, ceiling, crawl space, chimney, gas vent, or concealed space of a building.
- To reduce the risk of fire, **DO NOT** exhaust the dryer with plastic or thin foil ducting.
- The exhaust duct must be 4-inch (10.2 cm) in diameter with no obstructions. The exhaust duct should be kept as short as possible. Make sure to clean any old ducts before installing your new dryer.
- Rigid, semi-rigid or flexible metal ducting is recommended for use between the dryer and the wall. All non-rigid metal transition duct must be UL-listed. Use of other materials for transition duct could affect drying time.
- **DO NOT** use sheet metal screws or other fasteners which extend into the duct that could catch lint and reduce the efficiency of the exhaust system. Secure all joints with duct tape.
- Do not exceed the recommended duct length limitations noted in the chart. Failure to follow these instructions may result in extended drying times, fire or death.

WARNING

- Ductwork is not provided with the dryer. You should obtain the necessary ductwork locally. The vent hood should have hinged dampers to prevent backdraft when the dryer is not in use.
- The total length of flexible metal duct must not exceed 8 ft. (2.4 m).

Ductwork

Wall Cap Type	Number of 90° Elbows	Maximum length of 4-inch diameter rigid metal duct	
 a: 4" (10.2 cm)	Recommended	0	65 ft.(19.8 m)
		1	55 ft.(16.8 m)
		2	47 ft.(14.3 m)
		3	36 ft.(11.0 m)
 b: 2.5" (6.35 cm)	Use only for short run installations	0	55 ft.(16.8 m)
		1	47 ft.(14.3 m)
		2	41 ft.(12.5 m)
		3	30 ft.(9.1 m)
	4	22 ft.(6.7 m)	

NOTE

- Deduct 6 ft. (1.8 m) for each additional elbow. Do not use more than four 90° elbows.
- In Canada, only those foil-type flexible ducts, if any, specifically identified for use with the appliance by the manufacturer should be used. In the United States, only those foil-type flexible ducts, if any, specifically identified for use with the appliance by the manufacturer and that comply with the Outline for Clothes Dryer Transition Duct, Subject 2158A, should be used.

Routing and Connecting Ductwork

NOTE

Follow the guidelines below to maximize drying performance and reduce lint buildup and condensation in the ductwork. Ductwork and fittings are **NOT** included and must be purchased separately.

- Use 4-inch (10.2 cm) diameter rigid, semi-rigid or flexible metal ductwork.
- The exhaust duct run should be as short as possible.
- Use as few elbow joints as possible.
- The male end of each section of exhaust duct must point away from the dryer.
- Use duct tape on all duct joints.
- Insulate ductwork that runs through unheated areas in order to reduce condensation and lint buildup on duct surfaces.
- Incorrect or inadequate exhaust systems are not covered by the dryer warranty. Dryer failures or service required because of such exhaust systems will not be covered by the dryer warranty.

Correct Venting

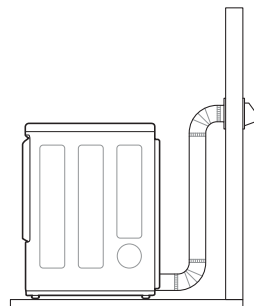

Incorrect Venting

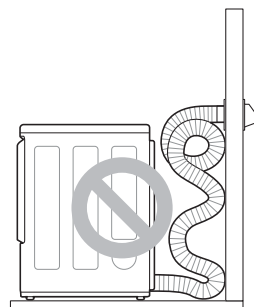

Connecting the Inlet Hose (Steam Models)

The dryer must be connected to the cold water tap using the new water supply hose. Do not reuse old hoses.

NOTE

- Water supply pressure must be between 20 and 120 psi (138—827 kPa).
- Do not strip or cross-thread when connecting the inlet hose to the valve.
- If the water supply pressure is more than 800 kPa, a pressure-reducing valve should be installed.
- Periodically check the condition of the hose and replace the hose if necessary.
- Replace inlet hoses after 5 years of use to reduce the risk of hose failure.
- Record hose installation or replacement dates on the hoses for future reference.

- 1 Check the rubber seal at each end of the inlet hoses. Two rubber seals are supplied with each inlet hose. They are used for preventing water leaks. Make sure the connection to the cold water tap is tight.

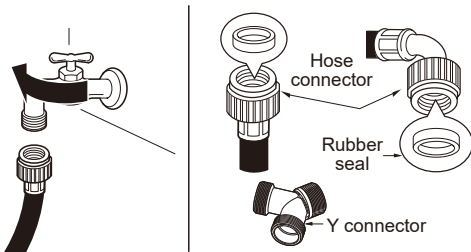

- 2 Check the installation type.

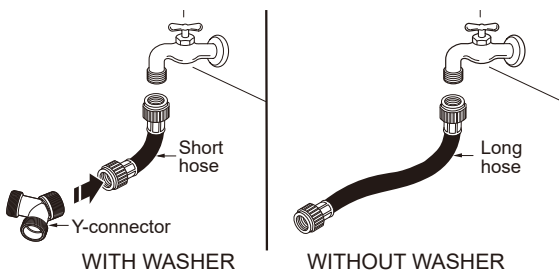

Connect all water supply hoses tightly by hand and then tighten another 2/3 turn with pliers.

WITH WASHER: When connecting the dryer to the same faucet as a washer.

- a. Shut off the cold water tap and remove the washer hose.
- b. Connect the short hose to the Y-connector using one of the rubber seals.
- c. Connect the other end of the short hose to the cold water faucet.
- d. Connect the long dryer hose to one side of the Y-connector and connect the washer hose to the other side.

WITHOUT WASHER: If the dryer does not share the cold water tap with a washer.

- a. Connect the straight end of the long hose to the cold water faucet.

NOTE

- Before connecting the water line to the dryer, flush several gallons of water into a drain or bucket. This will help prevent foreign particles such as sand and scale from clogging the dryer inlet valve.
- Do not overtighten. Damage to the coupling may result.

- 3 Connect the hose to the dryer. Connect the water supply hose to the dryer inlet valve tightly by hand and then tighten another 2/3 turn with pliers. Make sure that there are no kinks in the hoses and that they are not crushed.

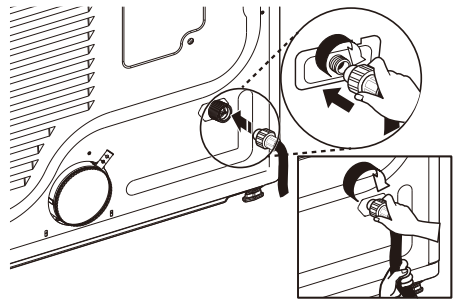

- 4 Turn on the cold water faucet.

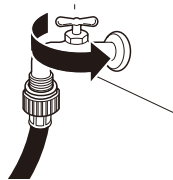

- 5 Check for leaks at the Y-connector (if used) and in all hoses.

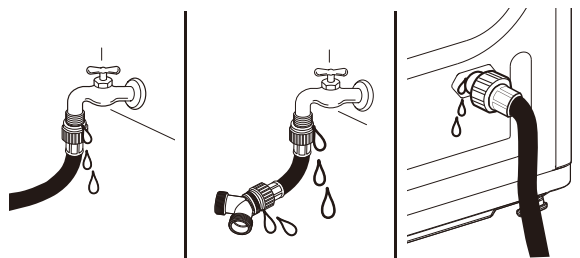

NOTE

- If any leaks are found, shut off the water faucet, remove the hose and check the condition of the rubber seal.

Connecting Gas Dryers

WARNING

To reduce the risk of fire or explosion, electric shock, property damage, injury to persons, or death when using this appliance, follow requirements including the following:

Electrical Requirements for Gas Models Only

- Do not, under any circumstances, cut or remove the third (ground) prong from the power cord.
- For personal safety, this dryer must be properly grounded.
- This dryer must be plugged into a 120-VAC, 60-Hz. grounded outlet protected by a 15-ampere fuse or circuit breaker.
- Where a standard 2-prong wall outlet is encountered, it is your personal responsibility and obligation to have it replaced with a properly grounded 3-prong wall outlet.

ELECTRIC SHOCK HAZARD

Failure to follow safety warnings could result in serious injury

- This dryer is equipped with a three-prong grounding plug for protection against shock hazard and should be plugged directly into a properly grounded three-prong receptacle. Do not cut or remove the grounding prong from this plug.

Gas Supply Requirements

- As shipped from the factory, this dryer is configured for use with natural gas (NG). It can be converted for use with propane (LP) gas. Gas pressure must not exceed 8-inch (20.4 cm) water column for NG, or 13-inch (33.1 cm) water column for LP.
- A qualified service or gas company technician must connect the dryer to the gas service.
- Isolate the dryer from the gas supply system by closing its individual manual shutoff valve during any pressure testing of the gas supply.
- DO NOT attempt any disassembly of the dryer; disassembly requires the attention and tools of an authorized and qualified service technician or company.
- Securely tighten all gas connections.
- Connect the dryer to the type of gas shown on the nameplate.

WARNING

Gas Supply Requirements (continued)

- Supply line requirements: Your laundry room must have a rigid gas supply line to your dryer. In the United States, an individual manual shutoff valve MUST be installed within at least 6 ft. (1.8 m) of the dryer, in accordance with the National Fuel Gas Code ANSI Z223.1 or Canadian gas installation code CSA B149.1. A 1/8-inch NPT pipe plug must be installed.
- If using a rigid pipe, the rigid pipe should be 0.5-inch IPS. If acceptable under local codes and ordinances and when acceptable to your gas supplier, 3/8-inch approved tubing may be used where lengths are less than 20 ft. (6.1 m). Larger tubing should be used for lengths in excess of 20 ft. (6.1 m).
- To prevent contamination of the gas valve, purge the gas supply of air and sediment before connecting the gas supply to the dryer. Before tightening the connection between the gas supply and the dryer, purge remaining air until the odor of gas is detected.
- DO NOT use an open flame to inspect for gas leaks. Use a noncorrosive leak detection fluid.
- Use only a new AGA- or CSA-certified gas supply line with flexible stainless steel connectors.
- Use Teflon tape or a pipe-joint compound that is insoluble in propane (LP) gas on all pipe threads.

Connecting the Gas Supply

- Installation and service must be performed by a qualified installer, service agency, or the gas supplier.
- Use only a new stainless steel flexible connector and a new AGA-certified connector.
- A gas shutoff valve must be installed within 6 ft. (1.8 m) of the dryer.
- The dryer is configured for natural gas when shipped from the factory. Make sure that the dryer is equipped with the correct burner nozzle for the type of gas being used (natural gas or propane gas).
- If necessary, the correct nozzle (for the LP nozzle kit, order part number 383EEL3002D) should be installed by a qualified technician and the change should be noted on the dryer.
- All connections must be in accordance with local codes and regulations. Gas dryers MUST exhaust to the outdoors.

NOTE

- In the Commonwealth of Massachusetts: This product must be installed by a licensed plumber or gas fitter. When using ball-type gas shut off valves, they shall be T-handle-type. A flexible gas connector, when used, must not exceed 3 feet.

This dryer is configured from the factory for natural gas (NG). If the dryer is to be used with propane (LP) gas, it must be converted by a qualified service technician.

- 1 Make sure that the gas supply to the laundry room is turned OFF and the dryer is unplugged. Confirm that the type of gas available in your laundry room is appropriate for the dryer.
- 2 Remove the shipping cap from the gas fitting at the back of the dryer. Be careful not to damage the threads of the gas connector when removing the shipping cap.
- 3 Connect the dryer to your laundry room's gas supply using a new flexible stainless steel connector with a 3/8-inch NPT fitting.

NOTE

- DO NOT use old connectors.

- 4 Securely tighten all connections between the dryer and your laundry room's gas supply.
- 5 Turn on your laundry room's gas supply.
- 6 Check all pipe connections (both internal and external) for gas leaks with a noncorrosive leak-detection fluid.
- 7 Proceed to Venting the Dryer.

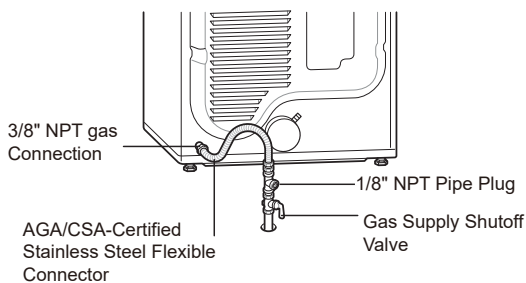
**High-Altitude Installations**

The BTU rating of this dryer is AGA-certified for elevations below 10,000 feet.

If your gas dryer is being installed at an elevation above 10,000 feet, it must be derated by a qualified technician or gas supplier.

Connecting Electric Dryers

WARNING

To reduce the risk of fire or explosion, electric shock, property damage, injury to persons, or death when using this appliance, follow requirements including the following:

Electrical Requirements for Electric Models Only

- The wiring and grounding must conform to the latest edition of the National Electrical Code, ANSI/NFPA 70 and all applicable local regulations. Please contact a qualified electrician to check your home's wiring and fuses to ensure that your home has adequate electrical power to operate the dryer.
- This dryer must be connected to a grounded metal, permanent wiring system, or an equipment-grounding conductor must be run with the circuit conductors and connected to the equipment-grounding terminal or lead on the dryer.
- The dryer has its own terminal block that must be connected to a separate 240 VAC, 60-Hertz, single-phase circuit, fused at 30 amperes (the circuit must be fused on both sides of the line). ELECTRICAL SERVICE FOR THE DRYER SHOULD BE OF THE MAXIMUM RATE VOLTAGE LISTED ON THE NAMEPLATE. DO NOT CONNECT THE DRYER TO 110-, 115-, OR 120-VOLT CIRCUIT.
- If the branch circuit to dryer is 15 ft. (4.5 m) or less in length, use UL (Underwriters Laboratories) listed No.-10 AWG wire (copper wire only), or as required by local codes. If over 15 ft. (4.5 m), use UL-listed No.-8 AWG wire (copper wire only), or as required by local codes. Allow sufficient slack in wiring so the dryer can be moved from its normal location when necessary.
- The power cord (pigtail) connection between the wall receptacle and the dryer terminal block IS NOT supplied with the dryer. Type of pigtail and gauge of wire must conform to local codes and with instructions on the following pages.

WARNING

- A 4-wire connection is required for all mobile and manufactured home installations, as well as all new construction after January 1, 1996. A 4-wire connection must be used where local codes do not permit grounding through the neutral wire.
- Do not modify the plug and internal wire provided with the dryer.
- The dryer should be connected to a 4-hole outlet.
- If the plug does not fit the outlet, a proper outlet will need to be installed by a qualified electrician.
- Connect the power cord to the terminal block. Each colored wire should be connected to the same color screw. Wire color indicated on manual is connected to the same color screw in the block.
- Grounding through the neutral conductor is prohibited for: (1) new branch-circuit installations, (2) mobile homes, (3) recreational vehicles, and (4) areas where local codes prohibit grounding through the neutral conductor.
- This dryer is supplied with the neutral wire grounded. This white ground wire **MUST BE MOVED** to the neutral terminal when a 4-wire cord is to be used, or where grounding through the neutral conductor is prohibited.

NOTE

- For electrical requirements for mobile or manufactured homes, see **Special Electrical Requirements**.

Four-Wire Power Cord

- A 4-wire connection is required for all mobile and manufactured home installations, as well as all new construction after January 1, 1996.
- A UL-listed strain relief is required.
- Use a 30-amp, 240-volt, 4-wire, UL-listed power cord with #10 AWG-minimum copper conductor and closed loop or forked terminals with upturned ends.

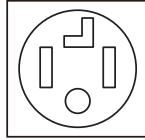

- 1 Remove the terminal block access cover on the upper back of the dryer.
- 2 Install a UL-listed strain relief into the power cord through-hole.
- 3 Thread a 30-amp, 240-volt, 4-wire, UL-listed power cord with #10 AWG-minimum copper conductor through the strain relief.

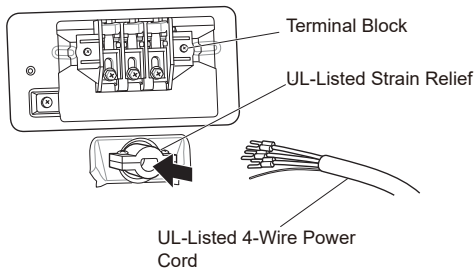

- 4 Transfer the dryer's ground wire from behind the green ground screw to the center screw of the terminal block.
- 5 Attach the two hot leads of the power cord to the outer terminal block screws.
- 6 Attach the white neutral wire to the center screw of the terminal block.
- 7 Attach the power cord ground wire to the green ground screw.

- 8 Tighten all screws securely.
- 9 Reinstall the terminal block access cover.

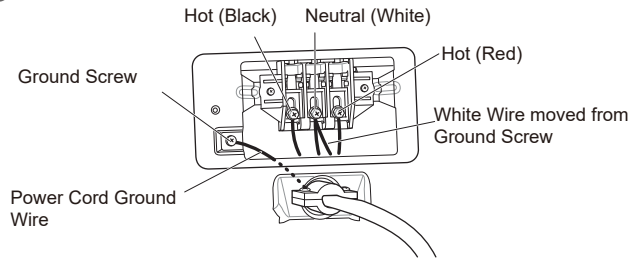

Four-Wire Direct Wire

- A 4-wire connection is required for all mobile and manufactured home installations, as well as all new construction after January 1, 1996.
- A UL-listed strain relief is required.
- Use UL-listed 4-wire #10 AWG-minimum copper conductor cable. Allow at least 5 ft. (1.5 m) of wire to allow for removal and reinstallation of the dryer.

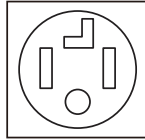

- 1 Remove 5-inch (12.7 cm) of the outer covering from the wire. Remove 5-inch of insulation from the ground wire. Cut off approximately 1.5-inch (3.8 cm) from the other three wires and strip 1 inch (2.5 cm) insulation from each wire. Bend the ends of the three shorter wires into a hook shape.

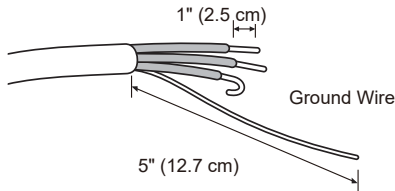

- 2 Remove the terminal block access cover on the upper back of the dryer.
- 3 Install a UL-listed strain relief into the power cord through-hole.
- 4 Thread the 4-wire #10 AWG-minimum copper power cable prepared in step 1 through the strain relief.

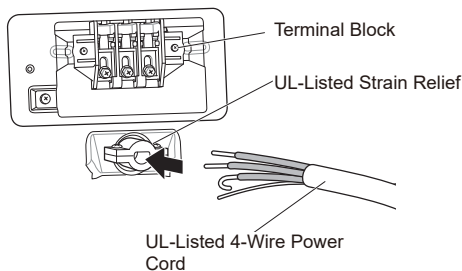

- 5 Transfer the dryer's ground wire from behind the green ground screw to the center screw of the terminal block.

- 6 Attach the two hot leads of the power cord to the outer terminal block screws.
- 7 Attach the white neutral wire to the center screw of the terminal block.
- 8 Attach the power cord ground wire to the green ground screw.
- 9 Tighten all screws securely.

- 10 Reinstall the terminal block access cover.

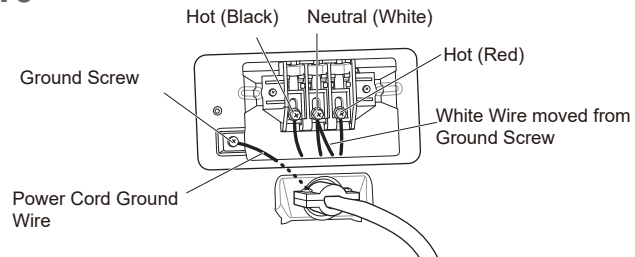

Three-Wire Power Cord

- A 3-wire connection is NOT permitted on new construction after January 1, 1996.
- A UL-listed strain relief is required.
- Use a 30-amp, 240-volt, 3-wire, UL-listed power cord with #10 AWG-minimum copper conductor and closed loop or forked terminals with upturned ends.

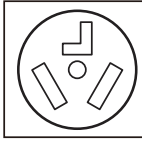

- 1 Remove the terminal block access cover on the upper back of the dryer.
- 2 Install a UL-listed strain relief into the power cord through-hole.
- 3 Thread a 30-amp, 240-volt, 3-wire, UL-listed power cord with #10 AWG-minimum copper conductor through the strain relief.

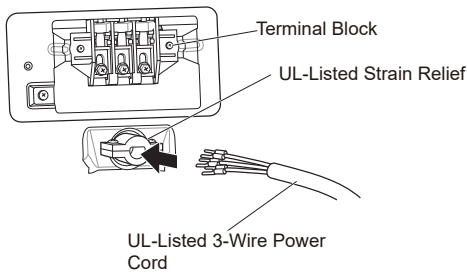

- 4 Attach the two hot leads (black and red) of the power cord to the outer terminal block screws.
- 5 Attach the neutral (white) wire to the center terminal block screw.
- 6 Connect the external ground (if required by local codes) to the green ground screw.
- 7 Tighten all screws securely.

- 8 Reinstall the terminal block access cover.

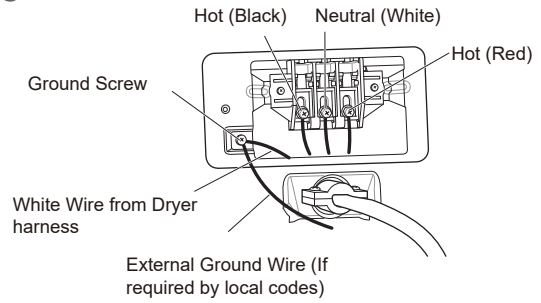

Three-Wire Direct Wire

- A 3-wire connection is NOT permitted on new construction after January 1, 1996.
- A UL-listed strain relief is required.
- Use UL-listed 3-wire, #10 AWG-minimum copper conductor cable. Allow at least 5 ft. (1.5 m) length to allow for removal and installation of dryer.

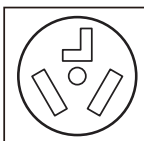

- 1 Remove 3.5-inch (8.9 cm) of the outer covering from the wire. Strip 1 inch (2.5 cm) insulation from each wire. Bend the ends of the three wires into a hook shape.

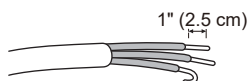

- 2 Remove the terminal block access cover on the upper back of the dryer.
- 3 Install a UL-listed strain relief into the power cord through-hole.
- 4 Thread the 3-wire, #10 AWG-minimum copper conductor power cable prepared in step 1 through the strain relief.

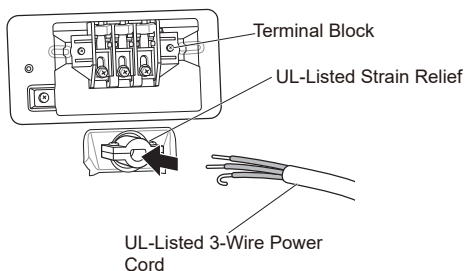

- 5 Attach the two hot leads (black and red) of the power cord to the outer terminal block screws.

- 6 Attach the neutral (white) wire to the center terminal block screw.
- 7 Connect the external ground (if required by local codes) to the green ground screw.
- 8 Tighten all screws securely.
- 9 Reinstall the terminal block access cover.

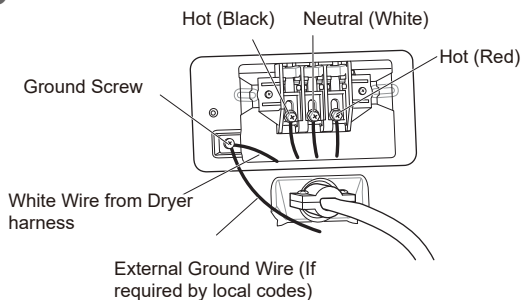

Special Electrical Requirements

(For Mobile or Manufactured Homes)

- Any installation in a manufactured or mobile home must comply with the Manufactured Home Construction and Safety Standards Title 24 CFR, Part 3280 or Standard CAN/ CSA Z240 MH and local codes and ordinances. If you are uncertain whether your proposed installation will comply with these standards, please contact a service and installation professional for assistance.
- A 4-wire connection is required for all mobile and manufactured home installations, as well as all new construction after January 1, 1996.
- A gas dryer must be permanently attached to the floor.
- The electrical connection for an electric dryer must be a 4-wire connection. More detailed information concerning the electrical connection is provided in the section Connecting Electric Dryers.
- To reduce the risk of combustion and fire, the dryer must be vented to the outside.
- DO NOT vent the dryer under a manufactured home or mobile home.
- Electric dryers may be vented to the outside using the back, left, right, or bottom panel.
- Gas dryers may be vented to the outside using the back, left, or bottom panel. Gas dryers may not be vented to the outside using the right side panel because of the burner housing.
- The dryer exhaust duct must be affixed securely to the manufactured or mobile home structure, and the exhaust duct must be made of a material that will resist fire and combustion. It is recommended that you use a rigid, semi-rigid or flexible metal duct.
- DO NOT connect the dryer exhaust duct to any other duct, vent, chimney, or other exhaust duct.
- Make sure the dryer has adequate access to outside fresh air to ensure proper operation. The opening for outside fresh air must be at least 25 sq. in (163 cm²).
- It is important that the clearance of the duct from any combustible construction be at least 2 inches (5 cm), and when venting the dryer to the outdoors, the dryer should be installed with a clearance of at least 1 inch (2.5 cm) at the sides and back of the dryer.
- Please be aware that venting materials are not supplied with the dryer. You must obtain the venting materials necessary for proper installation.

Final Installation Check

Once you have completed the installation of the dryer and it is in its final location, confirm proper operation with the following tests and Installation Test (Duct Check).

Testing Dryer Heating

GAS MODELS

Close the dryer door and press the **Power** button to turn the dryer on. Press the **Time Dry** and **Start/Pause** buttons to start the test. When the dryer starts, the igniter should ignite the main burner.

NOTE

- If all air is not purged from the gas line, the gas igniter may turn off before the main burner ignites. If this happens, the igniter will reattempt gas ignition after approximately two minutes.

ELECTRIC MODELS

Close the dryer door and press the **Power** button to turn the dryer on. Press the **Time Dry** and **Start/Pause** buttons to start the test. The exhaust air should be warm after the dryer has been operating for 3 minutes.

Checking Airflow

Effective dryer operation requires proper airflow. The adequacy of the airflow can be measured by evaluating the static pressure. Static pressure in the exhaust duct can be measured with a manometer, placed on the exhaust duct approximately 2 ft. (60.9 cm) from the dryer. Static pressure in the exhaust duct should not exceed 0.6 inch (1.5 cm). The dryer should be checked while the dryer is running with no load.

Checking Levelness

Once the dryer is in its final location, recheck the dryer to be sure it is level. Make sure it is level front to back and side to side, and that all four leveling feet are in firm contact with the floor.

Installation Test (Duct Check)

Once you have completed the installation of the dryer, use this test to make sure the condition of the exhaust system is adequate for proper operation of the dryer. This test should be performed to alert you to any serious problems in the exhaust system of your home.

- Your dryer features Flow Sense™, an innovative sensing system that automatically detects blockages and restrictions in dryer ductwork. Keeping ductwork clean of lint buildup and free of restrictions allows clothes to dry faster and reduces energy use.

NOTE

- The dryer should be cool before starting this test. If the dryer was warmed up during installation, run the Air Dry cycle for a few minutes to reduce the interior temperature.

Activating the Installation Test

- Remove the drying rack and literature, and then close the door.**

Do not load anything in the drum for this test, as it may affect the accuracy of the results.

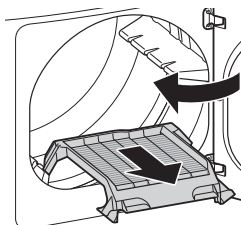

- (DLEX4200*, DLGX4201*, DLEX4000*, DLGX4001*, DLEX4500*, DLGX4501*) Press and hold Signal and Temp.**

(DLE3600*, DLG3601*) Press and hold Energy Saver and Temp.

Then press the Power button.

(On models with a glass touch control panel, press the **Power** button then IMMEDIATELY press and hold the other 2 buttons.

This button sequence activates the installation test. The code **1n5** will display if the activation is successful.

**(DLEX4200*,DLGX4201*
DLEX4000*,DLGX4001*,
DLEX4500*, DLGX4501*)**

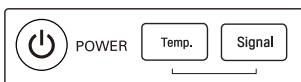

(DLE3600*,DLG3601*)

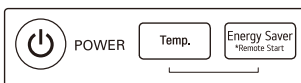

- Press the START/PAUSE button.**

The dryer will start the test, which will last a few minutes. The heat will be turned on and the temperatures in the drum will be measured.

- Check the display for results.**

(DLEX4200*,DLGX4201*, DLEX4000*, DLGX4001*, DLEX4500*, DLGX4501*)

During the test cycle, monitor the Flow Sense™ LED display on the control panel. If the Flow Sense™ LED has not turned on, when the cycle ends, the exhaust system is adequate. If the exhaust system is severely restricted, the Flow Sense™ LED will turn on. Other problems may also be shown with error codes. See the chart on the next page for error code details and solutions.



LED turned on:
RESTRICTED

The Flow Sense™ LED indicates that the exhaust system is severely restricted. Have the system checked immediately, as performance will be poor.

(DLE3600*,DLG3601*)

During the test cycle, monitor the Flow Sense™ display on the control panel. If no bars are displayed, when the cycle ends, the exhaust system is adequate. If the exhaust system is severely restricted, the display will show four bars. Other problems may also be shown with error codes. Refer to the next page for error code details and solutions.



Flow Sense

**NO BARS:
OK**



Flow Sense

**FOUR BARS:
RESTRICTED**

Four bars indicates that the exhaust system is severely restricted. Have the system checked immediately, as performance will be poor.

- End of cycle.**

(DLEX4200*,DLGX4201*, DLEX4000*, DLGX4001*, DLEX4500*, DLGX4501*)

At the end of the test cycle, **End** will display. The test cycle will end and the dryer will shut off automatically after a short delay.



(DLE3600*,DLG3601*)

At the end of the test cycle, **0** will display. The test cycle will end and the dryer will shut off automatically after a short delay.



Check the Duct Condition

If the Flow Sense™ Display is turned on, check the exhaust system for restrictions and damage. Repair or replace the exhaust system as needed.

NOTE

- When the dryer is first installed, this test should be performed to alert you to any existing problems with the exhaust duct in your home. However, since the test performed during normal operation provides more accurate information on the condition of the exhaust duct than the installation test, the number of bars displayed during the two tests may not be the same.
- Do not interrupt the test cycle, as this could result in inaccurate results.
- Even if the Flow Sense display does not light up during the test cycle, some restrictions may still be present in the exhaust system. Refer to the Venting the Dryer section of this manual for complete exhaust system and venting requirements.

Error Codes

Check the error code before you call for service.

Error Code	Possible Causes	Solutions
tE1 or tE2	Temperature sensor failure.	Turn off the dryer and call for service.
HS	Humidity sensor failure.	Turn off the dryer and call for service.
PS, PF, or nP	Electric dryer power cord is not connected correctly, or house power supply is incorrect.	Check the power supply or the connection of the power cord to the terminal block. Refer to the Connecting Electric Dryers section of this manual for complete instructions.
	House fuse is blown, circuit breaker has tripped, or power outage has occurred.	Reset circuit breaker or replace fuse. Do not increase the fuse capacity. If the problem is a circuit overload, have it corrected by a qualified electrician.
gAS	Gas supply or service turned off. (Gas Model only.)	Confirm that house gas shutoff and the dryer gas shutoff are both fully open.

Restricted or Blocked Airflow

Avoid long runs or runs with multiple elbows or bends.

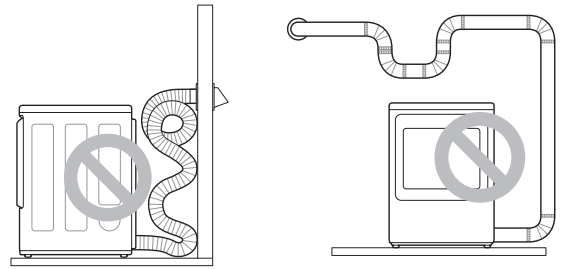

Excess or crushed transition duct

Too many elbows or exhaust too long

Check for blockages and lint buildup.

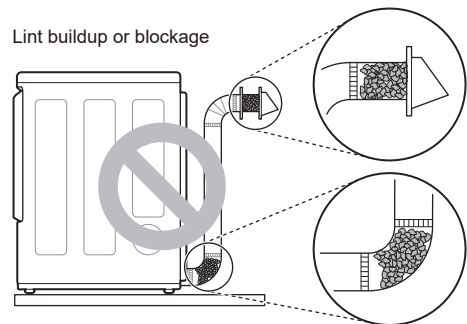

Make sure the ductwork is not crushed or restricted.

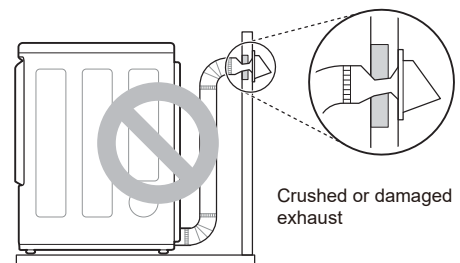

OPERATION

⚠ WARNING

- To reduce the risk of fire, electric shock, or injury to persons, read the SAFETY INSTRUCTIONS before operating this appliance.

Using the Dryer

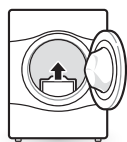

1 Clean the Lint Filter

If the lint filter has not already been cleaned, lift out the filter and remove the lint from the last load. This will help ensure the fastest and most efficient drying performance. Make sure to reinstall the filter, pressing down until it clicks firmly into place.

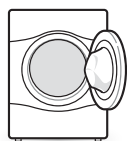

2 Load the Dryer

Load the dryer with the wet laundry from the washer. If the load is extra large, you may need to divide it into smaller loads for proper performance and fabric care.



3 Turn on the Dryer

Press the **Power** button to turn on the dryer. The cycle LEDs will illuminate and a chime will sound.



4 Select a Cycle

Turn the cycle selector knob in either direction until the LED for the desired cycle is on. The preset temperature, dry level, and option settings for that cycle will be shown. Default settings for the selected cycle can now be changed if desired. Refer to the Cycle Setting and Options page for details.

NOTE

- Not all options or modifiers are available on all cycles. Refer to the Cycle Guide page for default settings and available options. A different chime will sound and the LED will not come on if the selection is not available.



5 Begin Cycle

Press the **Start/Pause** button to begin the cycle. The cycle can be paused at any time either by opening the door or by pressing the **Start/Pause** button. If the cycle is not restarted within 14 minutes of being paused, the dryer will shut off and the settings will be lost.



6 End of Cycle

When the cycle is finished, the chime will sound. Immediately remove your clothing from the dryer to reduce wrinkling. If Wrinkle Care is selected, the dryer will tumble briefly every few minutes to help prevent wrinkles from setting in the clothes.

Check the Lint Filter Before Every Load

Always make sure the lint filter is clean before starting a new load; a clogged lint filter will increase drying time. To clean, pull the lint filter straight up and roll any lint off the filter with your fingers. Push the lint filter firmly back into place. See **Regular Cleaning** for more information.

Always ensure the lint filter is properly installed before running the dryer. Running the dryer with a loose or missing lint filter will damage the dryer and articles in the dryer.

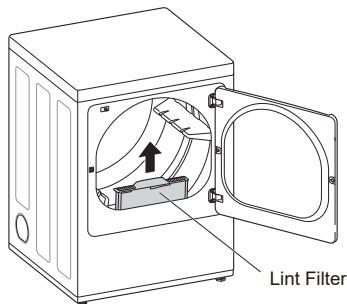

Sorting Laundry

Fabric Care Labels

Many articles of clothing include a fabric care label. Using the chart below, adjust the cycle and option selections to care for your clothing according to the manufacturer's recommendations.

Tumble dry			
	Dry		Gentle/delicate
	Normal		Do not tumble dry
	Permanent Press/ wrinkle resistant		Do not dry (used with do not wash)
Heat setting			
	High		Low
	Medium		No heat/air

Grouping Similar Items

For best results, sort clothes into loads that can be dried with the same drying cycle.

Different fabrics have different care requirements, and some fabrics will dry more quickly than others.

Loading the Dryer

WARNING

To reduce the risk of fire, explosion, electric shock, injury to persons, and death when using this appliance, follow basic precautions, including the following:

- Check all pockets to make sure that they are empty. Items such as clips, pens, coins, and keys can damage both the dryer and your clothes. Flammable objects such as lighters or matches could ignite, causing a fire.
- Never dry clothes that have been exposed to oil, gasoline, or other flammable substances. Washing clothes will not completely remove oil residues.

NOTE

Loading Tips

- Combine large and small items in the same load.
- Damp clothes will expand as they dry. Do not overload the dryer; clothes require room to tumble and dry properly.
- Use mesh laundry bags to separate clothes with zippers, hooks, straps, and drawstrings to prevent them from catching on or tangling with other clothes or damaging the lint filter.

Control Panel

Non-Steam Models (DLE3600*, DLG3601*)

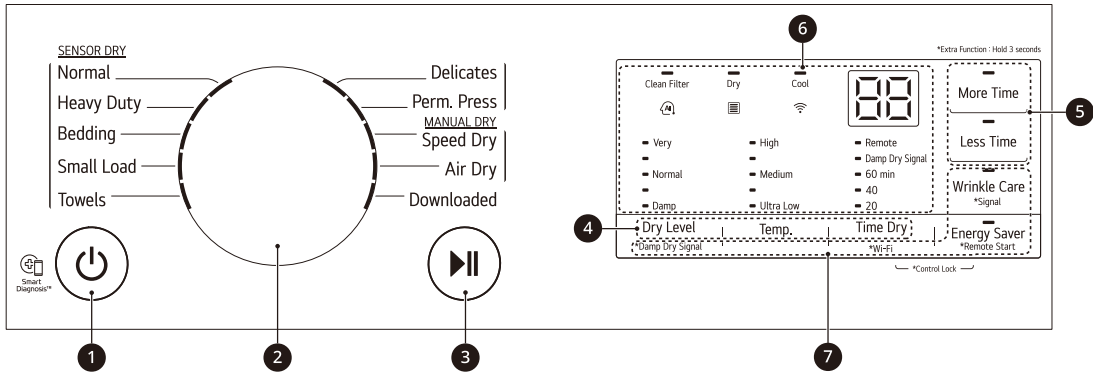

Steam Models (DLEX4000*, DLGX4001*)

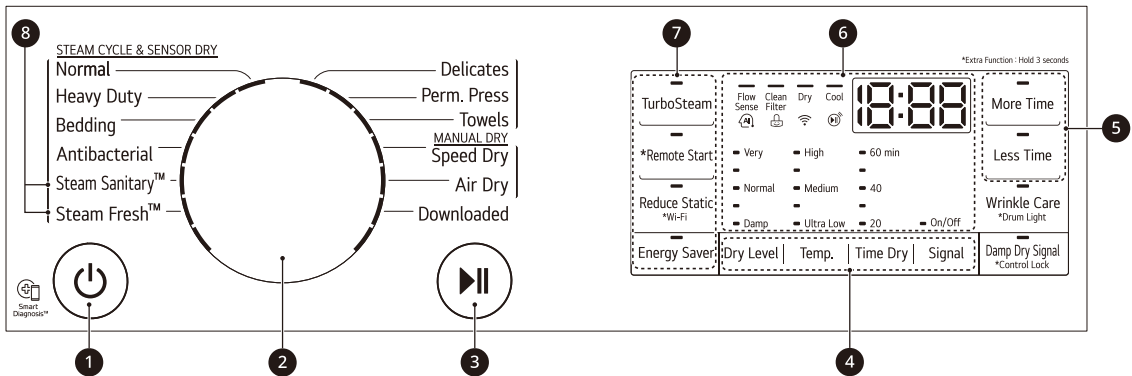

Steam Models (DLEX4200*, DLGX4201*, DLEX4500*, DLGX4501*)

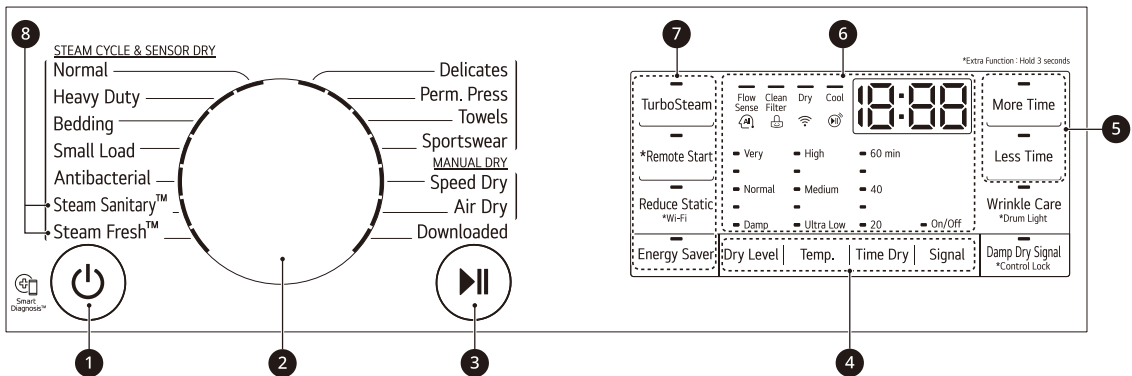

NOTE

- Model numbers can be found on the cabinet inside the door.

1 Power Button

Press the button to turn the dryer ON. Press again to turn the dryer OFF.

NOTE

- Pressing the **Power** button during a cycle will cancel that cycle and any load settings will be lost.

2 Cycle Selector Knob

Turn this knob to select the desired cycle. Once the desired cycle has been selected, the standard presets will be shown in the display. On Manual Dry cycles, these settings can be adjusted using the cycle modifier buttons anytime before starting the cycle.

3 Start/Pause Button

Press this button to start the selected cycle. If the dryer is running, use this button to pause the cycle without losing the current settings.

NOTE

- If you do not press the **Start/Pause** button to resume a cycle within 14 minutes, the dryer turns off automatically and all cycle settings are lost.

4 Cycle Modifier Buttons

Use these buttons to select the desired cycle settings for the selected cycle. The current settings are shown in the display. Press the button for that option to view and select other settings.

5 More Time/Less Time Buttons

Use these buttons with the Time Dry and other Manual Dry cycles to adjust the drying time. Press the **More Time** button to increase the selected manual cycle time by 5 minutes; press the **Less Time** button to decrease the cycle time by 5 minutes.

6 Time and Status Display

The display shows the settings, estimated time remaining, options, and status messages for the dryer.

7 Cycle Option Buttons

Press each of these buttons to select additional cycle options. Press and hold any button marked with an asterisk for 3 seconds to activate a special function.

8 Steam Functions

LG's steam technology allows you to inject fabrics with a swirling jet of steam to refresh clothes, reduce static, and make ironing easier. Simply select the **Steam Fresh™** or **Steam Sanitary™** cycle or add a Steam option to selected cycles.

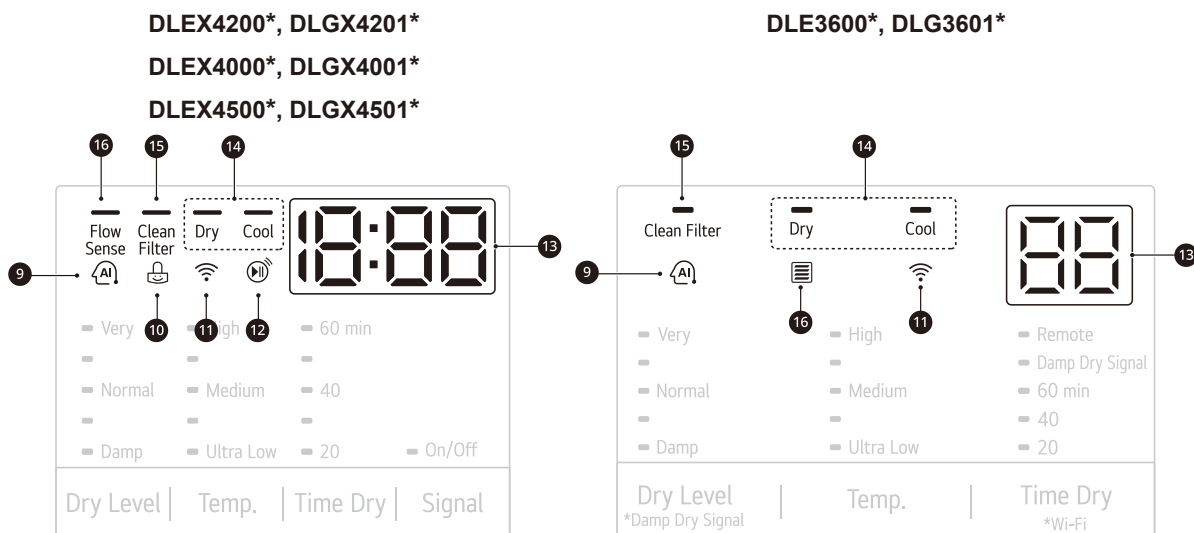

9 AI Sensor DRY Indicator

- AI Sensor Dry optimizes drying times and temperatures by detecting the laundry's characteristics.
- The indicator lights up when the Normal cycle is selected with the Normal dry level, except when the Energy Saver option is turned on.

10 Control Lock Indicator

When Control Lock is set, the Control Lock indicator appears and all buttons are disabled except the **POWER** button. This prevents children from changing settings while the dryer is operating.

11 Wi-Fi Indicator

When the appliance is connected to the Internet through a home Wi-Fi network, this indicator appears.

12 Remote Start Indicator

This indicator lights up when the **Remote Start** feature is activated.

13 Estimated Time Remaining

This display shows the estimated time remaining for Sensor Dry cycles or the actual time remaining for Time Dry or Manual Dry cycles.

NOTE

- The cycle time on Sensor Dry cycles may fluctuate as the dryer recalculates drying time for optimal results.

14 Cycle Completion Indicator

This portion of the display shows which stage of the drying cycle is currently underway (Dry or Cool).

15 Clean Filter Reminder

The display will show Clean Filter when the dryer is turned on as a reminder to clean the filter. It turns off when the **START/PAUSE** button is pressed.

16 Flow Sense Duct Blockage Sensing System Indicator

The Flow Sense™ duct blockage sensing system detects and alerts you to blockages in the ductwork that reduce exhaust flow from the dryer. Maintaining a clean exhaust system improves operating efficiency and helps minimize service calls, saving you money.

Cycle Guide

Sensor Dry Cycles

Sensor Dry cycles utilize LG's unique dual sensor system to detect and compare the moisture level in clothes and in the air and adjust the drying time as needed to ensure superior results. The dryer automatically sets the dryness level and temperature at the recommended setting for each cycle. The estimated time remaining will be shown in the display.

NOTE

- To protect your garments not every dryness level, temperature, or option is available with every cycle. See the Cycle Guide for details.

Manual Dry Cycles

Use Manual Dry cycles to select a specific amount of drying time and a drying temperature. When a Manual Dry cycle is selected, the Estimated Time Remaining display shows the actual time remaining in your cycle. You can change the actual time in the cycle by pressing the **More Time** or **Less Time** buttons.

NOTE

- The Energy Saver option is turned on by default in the Normal Cycle. Turn off the Energy Saver option for a faster Normal cycle which begins with heated drying. To turn the Energy Saver default off, press and hold the **Energy Saver** button. ON or OFF appears in the display.

Non-Steam Models (DLE3600*, DLG3601*)

☐ = default setting

● = allowable option

* = Energy Saver on by default

Cycle	Fabric Type	Dry Level	Temp.	Wrinkle Care	Damp Dry Signal
SENSOR DRY					
Normal*	Work clothes, corduroys, etc.	Normal	Med. High (between Medium and High)	●	●
		Adj.			
Heavy Duty	Jeans, heavyweight items	Normal	High	●	●
		Adj.			
Bedding	Comforters, Pillows, Shirts	Normal	Medium		
		Adj.			
Towels	Denim, towels, heavy cottons	Normal	Med. High (between Medium and High)	●	●
		Adj.			
Small Load	Only normal & cotton/towels fabric type (Max. 3 lb)	Normal	High	●	
		Adj.			
Perm. Press	Permanent press, synthetic items	Normal	Medium	●	●
		Adj.			
Delicates	Lingerie, sheets, blouses	Normal	Low (between Medium and Ultra Low)	●	●
		Adj.			
MANUAL DRY					
Speed Dry	For small loads with short drying times	Off	High	●	
			Adj.		
Air Dry	For items that require heat-free drying such as plastics or rubber	Off	No Heat	●	

Steam Models (DLEX4000*, DLGX4001*)

= default setting

● = allowable option

* = Energy Saver on by default

Cycle	Fabric Type	Dry Level	Temp.	Wrinkle Care	Damp Dry Signal	Reduce Static
SENSOR DRY						
Normal*	Work clothes, corduroys, etc.	Normal	Med. High (between Medium and High)	●	●	●
		Adj.				
Heavy Duty	Jeans, heavyweight items	Normal	High	●	●	●
		Adj.				
Bedding	Comforters, pillows, shirts	Normal	Medium			●
		Adj.				
Antibacterial	Do not use this cycle with delicate fabrics	Very	High	●		
Perm. Press	Permanent press, synthetic items	Normal	Medium	●	●	●
		Adj.				
Delicates	Lingerie, sheets, blouses	Normal	Low (between Medium and Ultra Low)	●	●	●
		Adj.				
Towels	Denim, towels, heavy cottons	Normal	Med. High (between Medium and High)	●	●	●
		Adj.				
MANUAL DRY						
Speed Dry	For small loads with short drying times	Off	High	●		●
			Adj.			
Air Dry	For items that require heat-free drying such as plastics or rubber	Off	No Heat	●		
STEAM CYCLE						
Steam Sanitary™	Comforters, bedding, children's clothing	Off	High	●		
Steam Fresh™	Comforters, shirts, trousers (except especially delicate fabrics)	Off	Med. High (between Medium and High)	●		
			Adj.			

Steam Models (DLEX4200*, DLGX4201*, DLEX4500*, DLGX4501*)
 = default setting

 = allowable option

* = Energy Saver on by default

Cycle	Fabric Type	Dry Level	Temp.	Wrinkle Care	Damp Dry Signal	Reduce Static
SENSOR DRY						
Normal*	Work clothes, corduroys, etc.	Normal	Med. High (between Medium and High)	●	●	●
		Adj.				
Heavy Duty	Jeans, heavyweight items	Normal	High	●	●	●
		Adj.				
Bedding	Comforters, pillows, shirts	Normal	Medium			●
		Adj.				
Small Load	Only normal & cotton/towels fabric type (Max. 3 lb)	Normal	High	●		
		Adj.				
Antibacterial	Do not use this cycle with delicate fabrics	Very	High	●		
Perm. Press	Permanent press, synthetic items	Normal	Medium	●	●	●
		Adj.				
Delicates	Lingerie, sheets, blouses	Normal	Low (between Medium and Ultra Low)	●	●	●
		Adj.				
Sportswear	Sportswear	Off		●		●
Towels	Denim, towels, heavy cottons	Normal	Med. High (between Medium and High)	●	●	●
		Adj.				
MANUAL DRY						
Speed Dry	For small loads with short drying times	Off	High	●		●
			Adj.			
Air Dry	For items that require heat-free drying such as plastics or rubber	Off	No Heat	●		
STEAM CYCLE						
Steam Sanitary™	Comforters, bedding, children's clothing	Off	High	●		
Steam Fresh™	Comforters, shirts, trousers (except especially delicate fabrics)	Off	Med. High (between Medium and High)	●		
			Adj.			

Cycle Modifier Buttons

Sensor Dry cycles have preset settings that are selected automatically. Manual Dry cycles have default settings, but you may also customize the settings using the cycle modifier buttons. Press the button for that option to view and select other settings.

Dry Level

Use this button to select the level of dryness for the cycle. Press the **Dry Level** button repeatedly to scroll through available settings.

- This option is only available with Sensor Dry cycles.
- The dryer will automatically adjust the cycle time. Selecting dry levels above Normal will increase the cycle time. Selecting dry levels below Normal will decrease the cycle time.
- Use the dry level between Normal and Damp or the Damp dry level for items that you wish to iron.

Temp.

Use this button to adjust the temperature setting. This allows precise care of fabrics and garments. Press the **Temp.** button repeatedly to scroll through available settings.

Time Dry

Use this button to manually select the drying time, from 20 to 60 minutes, in 10-minute increments. Use this for small loads or to remove wrinkles. Use the **More Time/Less Time** buttons to add or reduce the drying time in 5-minute increments.

Signal

The appliance plays a melody when the drying cycle is finished. The buttons make a sound each time a button is pressed. Use this button to turn the melody and button tones on or off.

(DLEX4200*, DLGX4201*, DLEX4000*, DLGX4001*, DLEX4500*, DLGX4501*)

- To turn on/off, press the Signal button.
- When this function is turned on, the On/Off LED on the display lights up.

(DLE3600*, DLG3601*)

- To turn on/off, press and hold the Wrinkle Care button for 3 seconds.

Option Buttons

The dryer features several additional cycle options to customize cycles to meet individual needs. Certain option buttons also feature a special function that can be activated by pressing and holding that option button for 3 seconds.

Adding Cycle Options to a Cycle

- 1 Turn on the dryer and turn the cycle selector knob to select the desired cycle.
- 2 Use the cycle modifier buttons to adjust the settings for that cycle.
- 3 Press the cycle option button(s) to add the desired options. A confirmation message is shown in the display.
- 4 Press the **Start/Pause** button to start the cycle. The dryer starts automatically.

Wrinkle Care

Selecting this option will tumble the load periodically for up to 3 hours after the selected cycle, or until the door is opened. This is helpful in preventing wrinkles when you are unable to remove items from the dryer immediately.

Damp Dry Signal

When this option is selected, the dryer signals when the load is approximately 80% dry. This allows you to remove faster-drying lightweight items or items that you would like to iron or hang while they are still slightly damp.

(DLEX4200*, DLGX4201*, DLEX4000*, DLGX4001*, DLEX4500*, DLGX4501*)

- To turn on/off, press the Damp Dry Signal button.

(DLE3600*, DLG3601*)

- To turn on/off, press and hold the Dry Level button for 3 seconds.

Energy Saver

This option helps to reduce the energy consumption of the Normal Cycle, depending on the load size. When the Energy Saver option is selected, the cycle begins with an air dry section and the drying time is increased.

Special Functions

Some cycle option buttons also activate secondary functions. These special functions are marked with an asterisk (*). Press and hold the option button marked with the special function to activate it.

Control Lock

Use this option to prevent unwanted use of the dryer or to keep cycle settings from being changed while the dryer is operating.

Activating the Control Lock Function

Press and hold the **below button(s)** for 3 seconds.

- **Damp Dry Signal** (DLEX4200*, DLGX4201*, DLEX4000*, DLGX4001*, DLEX4500*, DLGX4501*)
- **Time Dry** and **Energy Saver** (DLE3600*,DLG3601*)

When the controls are locked, [L and the remaining time are alternately shown on the display during the dry cycle. All controls will be disabled except the Power button.

Deactivating the Control Lock Function

Press and hold the **below button(s)** for 3 seconds.

- **Damp Dry Signal** (DLEX4200*, DLGX4201*, DLEX4000*, DLGX4001*, DLEX4500*, DLGX4501*)
- **Time Dry** and **Energy Saver** (DLE3600*,DLG3601*)

Once set, Control Lock remains active until it is manually deactivated. Control Lock must be turned off to run another cycle.

Drum Light

**(DLEX4200*, DLGX4201*,
DLEX4000*, DLGX4001*,
DLEX4500*, DLGX4501*)**

The drum is equipped with a blue LED that illuminates when the dryer is turned on. This light automatically turns off when the door is closed and the cycle starts. To turn on the light during a cycle, press and hold the Wrinkle Care button for three seconds. The drum light will illuminate and then turn off automatically after four minutes.

Steam Functions (Steam Models)

LG's new steam technology injects fabrics with a swirling jet of hot steam to refresh clothes, reduce static, and make ironing easier.

Simply select the Steam Fresh™ or Steam Sanitary™ cycle, or add a steam option to selected cycles.

WARNING

To reduce the risk of serious injury, death, explosion, or fire, follow basic safety precautions, including the following:

- Do not open the dryer door during steam cycles.
- Do not touch the steam nozzle in the drum during or after the steam cycle.

The Steam Sanitary™ Cycle

The Steam Sanitary™ cycle is ideal for sanitizing non-washable items quickly and easily using the power of steam.

Use this cycle for cotton and polyester material. (Do NOT use for urethane foam, down feathers or delicate items).

The Steam Fresh™ Cycle

Steam Fresh™ uses the power of steam to quickly reduce wrinkles and odors in fabrics. It brings new life to wrinkled clothes that have been stored for an extended time and makes heavily wrinkled clothes easier to iron. Steam Fresh™ can also be used to help reduce odors in fabrics.

NOTE

- The cycle time depends on the load (number of items). Press the **More Time** or **Less Time** button to change the display to reflect the number of items in the load. The display will show 1, 3, 5 or *b' 9*. 3 means 3 or fewer items, 5 is for 4 or 5 items, and *b' 9* indicates a large load such as a comforter.

Using the Steam Fresh™ Cycle

- 1 Turn on the dryer and turn the cycle selector knob to select the **Steam Fresh™** cycle.
- 2 To add an option, select **Wrinkle Care**.
- 3 The display shows the load size (number of items). Change the steam time by pressing the **More Time** or **Less Time** buttons to fit the size of the load.
- 4 Press **Start/Pause** to start the cycle.

The Steam Options

The Reduce Static option injects steam late in the drying cycle to reduce the static electricity caused by dry fabrics rubbing together.

NOTE

- When Sensor Dry is selected with the Reduce Static option, the dry levels below Normal cannot be selected.
- The Reduce Static option can also be selected during Time Dry cycles.
- After the Steam option is selected in Time Dry, the **More Time or Less Time** buttons will change the steam time ONLY.
- Press the **More Time** or **Less Time** button to adjust the cycle time depending on the size of the load (7, 9, 11, 14, 16, or 18 items).

Adding Steam to a Standard Cycle

- 1** Turn on the dryer and turn the cycle selector knob to select the desired cycle.
- 2** Use the cycle setting buttons to adjust the settings for that cycle.
- 3** Press Turbo Steam to add steam. If desired, select the Reduce Static or Wrinkle Care options. Then adjust for the load size using the More Time or Less Time buttons.
- 4** Press **Start/Pause** to start the cycle.

NOTE

- Steam may not be clearly visible during the steam cycles. This is normal.
- Do not use Steam Fresh™ with items such as wool, wool blankets, leather jackets, silk, wet clothes, lingerie, foam products, or electric blankets.
- For best results, load articles of similar size and fabric type. Do not overload.
- When the filter/duct is clogged, the steam option may not have optimal results.
- When the steam function is operating, the drum will stop to allow steam to stay in the drum.

Steam Cycle Guide

☐ = default setting

● = allowable option

	Steam	Default Time	Temp.	Dry Level	Fabric State	Fabric Type	Maximum Amount
Steam Sanitary™	Turbo Steam	31 minutes	High		Dry	Comforter Bedding	Single (1 each)
						Children's clothing	3 lbs.
Steam Fresh™	Turbo Steam	10 minutes	Med. High (between Medium and High)		Dry	Comforter	Single (1 each)
			Adj.			Shirts*	5 each
Steam Option	Reduce Static	Follows Selected Cycle		●	Wet	Varies by selected cycle	8 lbs. (18 Items.)
	Turbo Steam	Follows Selected Cycle		●	Wet	Varies by selected cycle	8 lbs. (18 Items.)
Time Dry	Reduce Static	38 minutes	High		Wet	Varies by selected cycle	8 lbs. (18 Items.)
			Adj.				

* Shirt: 70% cotton, 30% poly blend. Except especially delicate fabrics

SMART FUNCTIONS

LG ThinQ Application

The LG ThinQ application allows you to communicate with the appliance using a smartphone.

Before Using LG ThinQ

- 1 Use a smartphone to check the strength of the wireless router (Wi-Fi network) near the appliance.
 - If the distance between the appliance and the wireless router is too far, the signal strength becomes weak. It may take a long time to register or installation may fail.
- 2 Turn off the **Mobile data** or **Cellular Data** on your smartphone.

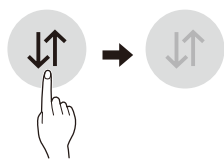

- 3 Connect your smartphone to the wireless router.

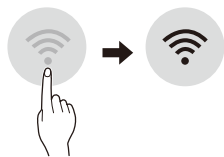

NOTE

- To verify the Wi-Fi connection, check that **Wi-Fi**  icon on the control panel is lit.
- The appliance supports 2.4 GHz Wi-Fi networks only. To check your network frequency, contact your Internet service provider or refer to your wireless router manual.
- LG ThinQ is not responsible for any network connection problems or any faults, malfunctions, or errors caused by network connection.
- The surrounding wireless environment can make the wireless network service run slowly.

- If the appliance is having trouble connecting to the Wi-Fi network, it may be too far from the router. Purchase a Wi-Fi repeater (range extender) to improve the Wi-Fi signal strength.
- The network connection may not work properly depending on the Internet service provider.
- The Wi-Fi connection may not connect or may be interrupted because of the home network environment.
- If the appliance cannot be registered due to problems with the wireless signal transmission, unplug the appliance and wait about a minute before trying again.
- If the firewall on your wireless router is enabled, disable the firewall or add an exception to it.
- The wireless network name (SSID) should be a combination of English letters and numbers. (Do not use special characters.)
- Smartphone user interface (UI) may vary depending on the mobile operating system (OS) and the manufacturer.
- If the security protocol of the router is set to **WEP**, network setup may fail. Change the security protocol (**WPA2** is recommended), and register the product again.

Installing the LG ThinQ Application

Search for the LG ThinQ application from the Google Play Store or Apple App Store on a smart phone. Follow instructions to download and install the application.

LG ThinQ Application Features

Dryer Cycle

Download new and specialized cycles that are not included in the standard cycles on the appliance.

Appliances that have been successfully connected can download a variety of specialty cycles specific to the appliance.

Only one cycle can be stored on the appliance at a time.

Once cycle download is completed in the appliance, the appliance keeps the downloaded cycle until a new cycle is downloaded.

Venting Tips

Provides venting tips.

Smart Diagnosis™

This function provides useful information for diagnosing and solving issues with the appliance based on the pattern of use.

Energy Monitoring

The dryer energy usage is affected by the cycles and options, so you may see some changes in energy usage from one cycle to another.

Push Alerts

When the cycle is complete or the appliance has problems, you have the option of receiving push notifications on a smart phone.

Settings

Set the product nickname and delete product.

NOTE

- To verify the Wi-Fi connection, check that the **Wi-Fi**  icon on the control panel is lit.
- LG ThinQ is not responsible for any network connection problems or any faults, malfunctions, or errors caused by network connection.
- The machine supports 2.4 GHz Wi-Fi networks only.
- If the appliance is having trouble connecting to the Wi-Fi network, it may be too far from the router. Purchase a Wi-Fi repeater (range extender) to improve the Wi-Fi signal strength.
- The Wi-Fi connection may not connect or may be interrupted because of the home network environment.
- The network connection may not work properly depending on the internet service provider.
- The surrounding wireless environment can make the wireless network service run slowly.
- This information is current at the time of publication. The application is subject to change for product improvement purposes without notice to users.

Using Remote Start

Use a smart phone to control the appliance remotely or check to see how much time is left in the cycle.

- 1 Press the **Power** button.
- 2 Load the laundry.
- 3 Press and hold the **Remote Start** button for 3 seconds to enable the Remote Start function.
- 4 Start a cycle from the LG ThinQ application on your smart phone.

NOTE

- Once the Remote Start mode is enabled, you can start a cycle from the LG ThinQ smartphone application. If the cycle is not started, the machine will wait to start the cycle until it is turned off remotely from the application or the Remote Start mode is disabled.
- If the door is opened, Remote Start is disabled.

Disabling Remote Start

When Remote Start is activated, press and hold the **Remote Start** button for 3 seconds.

Wireless LAN Module Specifications

Model	LCW-004
Frequency Range	2412 to 2462 MHz
Output Power (Max)	< 30 dBm

FCC Notice

This equipment has been tested and found to comply with the limits for a Class B digital device, pursuant to Part 15 of the FCC Rules. These limits are designed to provide reasonable protection against harmful interference in a residential installation. This equipment generates, uses, and can radiate radio frequency energy and, if not installed and used in accordance with the instructions, may cause harmful interference to radio communications. However, there is no guarantee that interference will not occur in a particular installation. If this equipment does cause harmful interference to radio or television reception, which can be determined by turning the equipment off and on, the user is encouraged to try to correct the interference by one or more of the following measures:

- Reorient or relocate the receiving antenna.
- Increase the separation between the equipment and the receiver.
- Connect the equipment to an outlet on a circuit different from that to which the receiver is connected.
- Consult the dealer or an experienced radio/TV technician for help.

This device complies with part 15 of the FCC Rules. Operation is subject to the following two conditions:

- 1) this device may not cause harmful interference and
- 2) this device must accept any interference received, including interference that may cause undesired operation of the device.

Any changes or modifications in construction of this device which are not expressly approved by the party responsible for compliance could void the user's authority to operate the equipment.

FCC RF Radiation Exposure Statement

This equipment complies with FCC radiation exposure limits set forth for an uncontrolled environment. This transmitter must not be co-located or operating in conjunction with any other antenna or transmitter.



This equipment should be installed and operated with a minimum distance of 20 cm (7.8 inches) between the antenna and your body. Users must follow the specific operating instructions for satisfying RF exposure compliance.

Open Source Software Notice Information

To obtain the source code under GPL, LGPL, MPL, and other open source licenses, that is contained in this product, please visit <http://opensource.lge.com>. In addition to the source code, all referred license terms, warranty disclaimers and copyright notices are available for download.

LG Electronics will also provide open source code to you on CD-ROM for a charge covering the cost of performing such distribution (such as the cost of media, shipping, and handling) upon email request to opensource@lge.com. This offer is valid for three (3) years from the date on which you purchased the product.

Smart Diagnosis™ Function

This feature is only available on models with the  or  logo.

Use this feature to help you diagnose and solve problems with your appliance.

NOTE

- For reasons not attributable to LGE's negligence, the service may not operate due to external factors such as, but not limited to, Wi-Fi unavailability, Wi-Fi disconnection, local app store policy, or app unavailability.
- The feature may be subject to change without prior notice and may have a different form depending on where you are located.

Using LG ThinQ to Diagnose Issues



If you experience a problem with your Wi-Fi equipped appliance, it can transmit troubleshooting data to a smartphone using the **LG ThinQ** application.

- Launch the **LG ThinQ** application and select the **Smart Diagnosis™** feature in the menu. Follow the instructions provided in the **LG ThinQ** application.

Using Audible Diagnosis to Diagnose Issues

Follow the instructions below to use the audible diagnosis method.

- Launch the **LG ThinQ** application and select the **Smart Diagnosis™** feature in the menu. Follow the instructions for audible diagnosis provided in the **LG ThinQ** application.

- 1 Press the **Power** button to turn on the appliance.
 - Do not press any other buttons.
- 2 Hold the mouthpiece of your phone in front of the  or  logo.

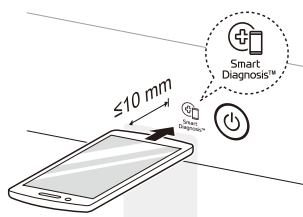

- 3 Press and hold the **Temp.** button for 3 seconds or longer while continuing to hold your phone near the logo.
- 4 Keep the phone in place until the tone transmission has finished. The display will count down the time. Once the countdown is over and the tones have stopped, the diagnosis will be displayed in the application.

NOTE

- For best results, do not move the phone while the tones are being transmitted.

MAINTENANCE

Regular Cleaning

WARNING

To reduce the risk of fire, electric shock, injury to persons, or death when using this appliance, follow basic precautions, including the following:

- Unplug the dryer before cleaning.
- Never use harsh chemicals, abrasive cleaners, or solvents to clean the washer. They will damage the finish.

Cleaning the Exterior

Proper care of your dryer can extend its life. The outside of the machine can be cleaned with warm water and a mild, nonabrasive household detergent. Immediately wipe off any spills with a soft, damp cloth.

NOTE

- Do not use methylated spirits, solvents, or similar products.
- Never use steel wool or abrasive cleansers; they can damage the surface.

Cleaning the Interior

Wipe around the door opening and seal with a soft, damp cloth to prevent lint and dust buildup that could damage the door seal.

Clean the window with a soft cloth dampened with warm water and a mild, nonabrasive household detergent, then wipe dry.

The stainless steel drum can be cleaned with a conventional stainless steel cleaner, used according to the manufacturer's specifications. Never use steel wool or abrasive cleansers; they may scratch or damage the surface.

Cleaning Around and Under the Dryer

Vacuum lint and dust from around the dryer and underneath it regularly. Vent ductwork should be checked for lint buildup and cleaned at least once per year. If any noticeable reduction in airflow or drying performance occurs, immediately check ductwork for obstructions and blockages.

Maintaining Ductwork

Vent ductwork should be checked for lint buildup once per month and cleaned at least once per year. If any noticeable reduction in airflow or drying performance occurs, immediately check ductwork for obstructions and blockages. Contact a qualified technician or service provider.

Cleaning the Lint Filter

Always clean the lint from the filter after every cycle.

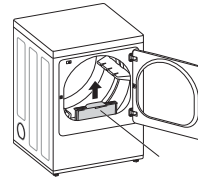

Lint Filter

To clean the lint filter, open the dryer door and pull the lint filter straight up. Then:

- 1 For everyday cleaning, roll any lint off the filter with your fingers, or

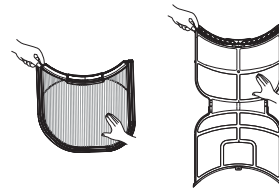

- 2 Vacuum the lint filter.

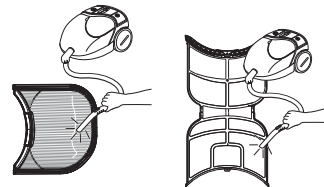

- 3 If the lint filter has become very dirty or clogged with fabric softener, wash the lint filter in warm, soapy water and allow it to dry thoroughly before reinstalling.

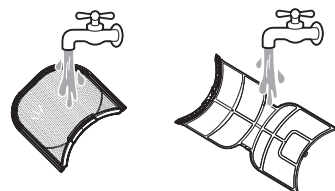

NOTE

- NEVER operate the dryer without the lint filter in place.

TROUBLESHOOTING

FAQs: Frequently Asked Questions

Q: When I press a button, why does my dryer beep and then nothing happens?

A: The Control Lock feature is turned on. To turn off Control Lock, turn the dryer on, then press and hold the button that has ***Control Lock** on or under it for 3 seconds.

Q: Why does my dryer take so long to dry clothes?

A: Proper airflow is critical to the efficient operation of clothes dryers. A lint filter which is full of lint or clogged with fabric softener sheet residue can reduce the airflow to the point that the time required to dry clothing will be greatly increased. Another factor affecting dry time is your home exhaust system. An exhaust system which is dirty and clogged with lint, or is excessively long, needs to be professionally cleaned or repaired.

Q: Why does my dryer start by itself every few minutes?

A: This is how the Wrinkle Care feature works. The dryer runs briefly every few minutes for up to 3 hours after the cycle finishes. This feature is designed to help prevent wrinkles from setting in when the dryer is not unloaded immediately after the cycle is finished.

Q: Why does my dryer show 3 minutes when I select the Steam Fresh™ cycle?

A: When the Steam Fresh™ cycle is selected, the dryer displays the recommended number of garments for the cycle, not the estimated cycle time, until the cycle is started. Use the **More Time or Less Time** buttons to adjust the load size setting for the number of garments you desire. For a large load or single bulky item use the *b' 9* (big) setting.

User Support Videos

For further assistance, there are videos and tutorials available through the LG.com website.

- 1 On the lg.com/us home page, click on the Support menu tab to bring up the menu selections. Select **Video Tutorials**.
- 2 Type **Dryer** in the search box on the new page and click the Search button.



Scan this QR code to quickly access the video search page on the LG website.

Before Calling for Service

This dryer is equipped with an automatic error-monitoring system to detect and diagnose problems at an early stage. If the dryer does not function properly or does not function at all, check the following before you call for service.

Operation

Problem	Possible Cause	Solutions
The Flow Sense™ indicator remains active after clearing the restriction in the venting.	After clearing the restriction, the Flow Sense™ system requires multiple, consecutive cycles to determine that the performance value has improved before the Flow Sense™ indicator is reset.	<ul style="list-style-type: none"> • If the Flow Sense™ indicator remains active for more than five cycles after the restriction has been cleared, call for service.
Dryer will not turn on	Power cord is not properly plugged in.	<ul style="list-style-type: none"> • Make sure that the plug is securely plugged into a grounded outlet matching the dryer's rating plate.
	House fuse is blown, circuit breaker has tripped, or power outage has occurred.	<ul style="list-style-type: none"> • Reset circuit breaker or replace fuse. Do not increase fuse capacity. If the problem is a circuit overload, have it corrected by a qualified electrician.
Dryer does not heat	House fuse is blown, circuit breaker has tripped, or power outage has occurred.	<ul style="list-style-type: none"> • Reset circuit breaker or replace fuse. Do not increase fuse capacity. If the problem is a circuit overload, have it corrected by a qualified electrician. • NOTE: Due to the design of electric dryers, it is possible for a circuit problem to allow an electric dryer to run without heat.
	Gas supply or service is turned off.	<ul style="list-style-type: none"> • Confirm that the house gas shutoff and the dryer gas shutoff valves are both fully open. Even if gas is not supplied to the dryer, it will run and no error codes will display. Verify that other gas appliances in the home are working normally.
	ENERGY SAVER option selected (on some models)	<ul style="list-style-type: none"> • If using the Normal cycle, deselect the ENERGY SAVER option. The Energy Saver option is selected by default. This option reduces energy use by adding an air dry section to the beginning of the cycle. It is normal to feel no heat at the beginning of the cycle while in ENERGY SAVER mode.
Clothes take too long to dry	Exhaust ducts are blocked, dirty, or duct run is too long.	<ul style="list-style-type: none"> • Confirm that the exhaust duct is properly configured and free of debris, lint, and obstructions. Make sure that outside wall dampers can open properly and are not blocked, jammed, or damaged.
	Load is not properly sorted.	<ul style="list-style-type: none"> • Separate heavy items from lightweight items. Larger and heavier items take longer to dry. Light items in a load with heavy items can fool the sensor because the light items dry faster.
Display shows error code nP	Electric dryer power cord is not connected correctly, or house power supply is incorrect.	<ul style="list-style-type: none"> • Check the power supply or the connection of the power cord to the terminal block.
Display shows error code gAS	Gas supply or service turned off (gas models only).	<ul style="list-style-type: none"> • Confirm that house gas shutoff and the dryer gas shutoff are both fully open.

Problem	Possible Cause	Solutions
Clothes take too long to dry	Large load of heavy fabrics.	<ul style="list-style-type: none"> • Heavy fabrics take longer to dry because they tend to retain more moisture. To help reduce and maintain more consistent drying times for large and heavy fabrics, separate these items into smaller loads of a consistent size.
	Dryer controls are not set properly.	<ul style="list-style-type: none"> • Use the appropriate control settings for the type of load you are drying. Some loads may require an adjustment of the dry level setting for proper drying.
	Lint filter needs to be cleaned.	<ul style="list-style-type: none"> • Remove the lint from the filter before every load. With the lint removed, hold the filter up to a light to see if it is dirty or clogged. With some loads that produce high amounts of lint, such as new bath towels, it may be necessary to pause the cycle and clean the filter during the cycle.
	House fuse is blown, circuit breaker has tripped, or power outage has occurred.	<ul style="list-style-type: none"> • Reset circuit breaker or replace fuse. Do not increase fuse capacity. If the problem is a circuit overload, have it corrected by a qualified electrician. • NOTE: Due to the design of electric dryers, it is possible for a circuit problem to allow an electric dryer to run without heat.
	Dryer is overloaded.	<ul style="list-style-type: none"> • Divide extra large loads into smaller loads for better drying performance and efficiency.
	Dryer is underloaded.	<ul style="list-style-type: none"> • If you are drying a very small load, add a few extra items to ensure proper tumbling action. If the load is very small and you are using SENSOR DRY cycles, the electronic control cannot properly sense the dryness of the load and may shut off too soon. Use TIME DRY or add some extra wet clothes to the load.
	ENERGY SAVER option selected (on some models)	<ul style="list-style-type: none"> • If using the Normal cycle, deselect the ENERGY SAVER option. This option reduces energy use by adding an air dry section to the beginning of the cycle.
Drying time is not consistent	Heat settings, load size, or dampness of clothing is not consistent.	<ul style="list-style-type: none"> • The drying time for a load will vary depending on the type of heat used (electric, natural gas, or LP gas), the size of the load, the type of fabrics, the wetness of the clothes, and the condition of the exhaust duct and lint filter. Even an unbalanced load in the washer can cause poor spinning, resulting in wetter clothes which will take longer to dry.

Performance

Problem	Possible Cause	Solutions
Greasy or dirty spots on clothes	Fabric softener used incorrectly.	<ul style="list-style-type: none"> Confirm and follow the instructions provided with your fabric softener.
	Clean and dirty clothes are being dried together.	<ul style="list-style-type: none"> Use your dryer to dry only clean items. Soil from dirty clothes can transfer to the clean clothes in the same or later loads.
	Clothes were not properly cleaned or rinsed before being placed in the dryer.	<ul style="list-style-type: none"> Stains on dried clothes could be stains that were not removed during the washing process. Make sure that clothes are being completely cleaned or rinsed according to the instructions for your washer and detergent. Some difficult soils may require pre-treating prior to washing.
Clothes are wrinkled	Clothes dried too long (over dried).	<ul style="list-style-type: none"> Over drying a load of laundry can lead to wrinkled clothes. Try a shorter drying time or LESS DRY setting and remove items while they still retain a slight amount of moisture.
	Clothes left in dryer too long after cycle ends.	<ul style="list-style-type: none"> Use the WRINKLE CARE option. This feature will tumble the clothes briefly every few minutes for up to 3 hours to help prevent wrinkling.
Clothes are shrinking	Garment care instructions are not being followed.	<ul style="list-style-type: none"> To avoid shrinking your clothes, always consult and follow fabric care instructions. Some fabrics will naturally shrink when washed. Other fabrics can be washed but will shrink when dried in a dryer. Use a low or no heat setting.
Lint on clothes	Lint filter not cleaned properly.	<ul style="list-style-type: none"> Remove the lint from the filter before every load. With the lint removed, hold the filter up to a light to see if it is dirty or clogged. If it looks dirty, follow the cleaning instructions. With some loads that produce high amounts of lint, it may be necessary to clean the filter during the cycle.
	Laundry not sorted properly.	<ul style="list-style-type: none"> Some fabrics are lint producers (i.e., a fuzzy white cotton towel) and should be dried separately from clothes that are lint trappers (i.e., a pair of black linen pants).
	Excess static in clothes.	<ul style="list-style-type: none"> Use a fabric softener to reduce static electricity. Be sure to follow the manufacturer's instructions. Overdrying a load of laundry can cause a buildup of static electricity. Adjust settings and use a shorter drying time, or use SENSOR DRY cycles.
	Dryer is overloaded.	<ul style="list-style-type: none"> Divide extra large loads into smaller loads for drying.
	Tissue, paper, etc., left in pockets.	<ul style="list-style-type: none"> Check pockets thoroughly before washing and drying clothes.

Problem	Possible Cause	Solutions
Excess static in clothes after drying	Fabric softener is not used or used incorrectly.	<ul style="list-style-type: none"> • Use a fabric softener or the REDUCE STATIC option, if equipped, to reduce static electricity. Be sure to follow the manufacturer's instructions.
	Clothes dried too long (overdried).	<ul style="list-style-type: none"> • Overdrying a load of laundry can cause a buildup of static electricity. Adjust settings and use a shorter drying time, or use MANUAL DRY cycles. Select a LESS DRY setting on SENSOR DRY cycles, if necessary.
	Drying synthetics, permanent press, or synthetic blends.	<ul style="list-style-type: none"> • These fabrics are naturally more prone to static buildup. Try using fabric softener, or use LESS DRY and/or shorter TIME DRY time settings.
Clothes have damp spots after a Sensor Dry cycle.	Very large load or very small load. Single large item such as a blanket or comforter.	<ul style="list-style-type: none"> • If items are too tightly packed or too sparse the sensor may have trouble reading the dryness level of the load. Use a TIME DRY cycle for very small loads. • Large, bulky items such as blankets or comforters can sometimes wrap themselves into a tight ball of fabric. The outside layers will dry and register on the sensors, while the inner core remains damp. When drying a single bulky item, it may help to pause the cycle once or twice and rearrange the item to unwrap and expose any damp areas. • To dry a few remaining damp items from a very large load or a few damp spots on a large item after a sensor cycle has completed, empty the lint trap, then set a TIME DRY cycle to finish drying the item(s).
Trouble connecting appliance and smartphone to Wi-Fi network	The password for the Wi-Fi network was entered incorrectly.	<ul style="list-style-type: none"> • Delete your home Wi-Fi network and begin the registration process again.
	Mobile data for your smartphone is turned on.	<ul style="list-style-type: none"> • Turn off the Mobile data on your smartphone before registering the appliance.
	The wireless network name (SSID) is set incorrectly.	<ul style="list-style-type: none"> • The wireless network name (SSID) should be a combination of English letters and numbers. (Do not use special characters.)
	The router frequency is not 2.4 GHz.	<ul style="list-style-type: none"> • Only a 2.4 GHz router frequency is supported. Set the wireless router to 2.4 GHz and connect the appliance to the wireless router. To check the router frequency, check with your Internet service provider or the router manufacturer.
	The appliance is too far from the router.	<ul style="list-style-type: none"> • If the appliance is too far from the router, the signal may be weak and the connection may not be configured correctly. Move the router closer to the appliance or purchase and install a Wi-Fi repeater.

Steam Functions (Steam Models)

Problem	Possible Cause	Solutions
Water drips from nozzle when STEAM CYCLE starts	This is normal.	<ul style="list-style-type: none"> This is steam condensation. The dripping water will stop after a short time.
Garments still wrinkled after Steam Fresh™	Too many or overly different types of garments in dryer.	<ul style="list-style-type: none"> Small loads of 1 to 5 items work best. Load fewer garments. Load similar types of garments.
Creases or pleats are gone from garments after Steam Fresh™	The function of this cycle is to remove wrinkles from fabric.	<ul style="list-style-type: none"> Use an iron to replace creases and pleats in garments.
Garments have static after using the Reduce Static option	This is normal.	<ul style="list-style-type: none"> The amount of static experienced will depend on the individual moisture level in the skin.
Garments are too damp or too dry after using the Reduce Static option	Correct drying options not selected.	<ul style="list-style-type: none"> Select the load weight manually before starting the Reduce Static option.
Steam does not generate, but no error code is shown	Water level error.	<ul style="list-style-type: none"> Unplug dryer and call for service.
Water drips from door during STEAM CYCLE	This is normal.	<ul style="list-style-type: none"> Condensation will normally form on the inside of the dryer door during steam operation. Some condensation may drip out the bottom of the door.
Steam is not visible during STEAM CYCLE	This is normal.	<ul style="list-style-type: none"> Steam vapor is difficult to see when the door is closed. However, condensation will normally form on the inside of the dryer door if the steam system is operating normally.
Drum does not turn during STEAM CYCLE	This is normal.	<ul style="list-style-type: none"> The drum is turned off so that the steam vapor remains in the drum. The drum will normally turn for about 2 seconds once a minute.
Cannot see steam vapor at the beginning of cycle	This is normal.	<ul style="list-style-type: none"> Steam is released at different stages of the cycle for each option.
Odors remain in clothing after Steam Fresh™	Steam Fresh™ did not remove odor completely.	<ul style="list-style-type: none"> Fabrics containing strong odors should be washed in a normal cycle.

Error Codes

Problem	Possible Cause	Solutions
Error code: tE1 through tE7	Temperature sensor failure.	<ul style="list-style-type: none"> • Turn off the dryer and call for service.
Display shows error code: PS	Power cord is connected incorrectly.	<ul style="list-style-type: none"> • Check the connection of the power cord to the terminal block.
<p>*Flow Sense™ indicator shows four bars during the drying cycle or the display shows "d80" after drying</p> <p>* This warning light is not a dryer failure and is not covered by the dryer warranty. Contact a duct cleaning service to set up an appointment to have your exhaust system cleaned and inspected.</p>	Exhaust system is too long or has too many turns/restrictions.	<ul style="list-style-type: none"> • Install a shorter or straighter duct run. See the Installation Instructions for details.
	Partial blockage of the ductwork due to lint buildup or other foreign object.	<ul style="list-style-type: none"> • Ductwork should be checked/cleaned immediately. Dryer can be used in this condition, but drying times will be longer and energy consumption will increase.
	The appliance has detected a restriction in the external dryer venting.	<ul style="list-style-type: none"> • If exhaust restrictions are sensed by the Flow Sense™ system, the indicator will remain on for 2 hours after the end of the cycle. Opening the door or pressing the Power button will turn off the display.
The Flow Sense™ indicator remains active after clearing the restriction in the venting.	After clearing the restriction, the Flow Sense™ system requires multiple, consecutive cycles to determine that the performance value has improved before the Flow Sense™ indicator is reset.	<ul style="list-style-type: none"> • If the Flow Sense™ indicator remains active for more than five cycles after the restriction has been cleared, call for service.
The display shows <i>b19</i>	More Time button was pressed.	<ul style="list-style-type: none"> • This display indicates that the steam option has been set for a "big" item such as a comforter. Press the LESS TIME button to reduce the indicated load size.
<p>The display shows</p> 	The duct work is about 80% - 95% blocked. ("d80", "d90" or "d95" error code is displayed for 2 hours only)	<ul style="list-style-type: none"> • Do not use the dryer until the exhaust system has been cleaned and/or repaired. Using the dryer with a severely restricted exhaust is dangerous and could result in a fire or other property damage. Check the outside dryer vent while the dryer is operating to make sure there is strong airflow. If the exhaust system is extremely long, have it repaired or rerouted.
	House exhaust system blocked.	<ul style="list-style-type: none"> • Keep the area around the dryer clean and free of clutter. Check vent hood for damage or lint clogging. Make sure the area around the vent hood is clear.
Check Filter indicator is on during the drying cycle	Lint filter not cleaned properly.	<ul style="list-style-type: none"> • Remove the lint from the filter before every load. With the lint removed, hold the filter up to a light to see if it is dirty or clogged. If it looks dirty, follow the cleaning instructions. With some loads that produce high amounts of lint, it may be necessary to clean the filter during the cycle.

WARRANTY

ARBITRATION NOTICE: THIS LIMITED WARRANTY CONTAINS AN ARBITRATION PROVISION THAT REQUIRES YOU AND LG TO RESOLVE DISPUTES BY BINDING ARBITRATION INSTEAD OF IN COURT, UNLESS YOU CHOOSE TO OPT OUT. IN ARBITRATION, CLASS ACTIONS AND JURY TRIALS ARE NOT PERMITTED. PLEASE SEE THE SECTION TITLED "PROCEDURE FOR RESOLVING DISPUTES" BELOW.

Should your LG Dryer ("Product") fail due to a defect in materials or workmanship under normal home use, during the warranty period set forth below, LG will at its option repair or replace the product. This limited warranty is valid only to the original retail purchaser of the product and applies only when purchased and used within the United States including U.S. Territories. Proof of original retail purchase is required to obtain warranty service under this limited warranty.

Warranty Period	Scope of Warranty	HOW SERVICE IS HANDLED
One (1) year from date of original retail purchase	Parts and Labor	LG will provide parts and labor to repair or replace defective parts.
Three (3) years from date of original retail purchase	Dryer drum	Parts only. Customer will be responsible for any labor or in-home service to replace defective parts.

- Replacement products and parts are warranted for the remaining portion of the original warranty period or ninety (90) days, whichever is greater.
- Replacement products and parts may be new or remanufactured.



THIS WARRANTY IS IN LIEU OF ANY OTHER WARRANTY, EXPRESS OR IMPLIED, INCLUDING WITHOUT LIMITATION, ANY WARRANTY OF MERCHANTABILITY OR FITNESS FOR A PARTICULAR PURPOSE. TO THE EXTENT ANY IMPLIED WARRANTY IS REQUIRED BY LAW, IT IS LIMITED IN DURATION TO THE EXPRESS WARRANTY PERIOD ABOVE. NEITHER THE MANUFACTURER NOR ITS U.S. DISTRIBUTOR SHALL BE LIABLE FOR ANY INCIDENTAL, CONSEQUENTIAL, INDIRECT, SPECIAL, OR PUNITIVE DAMAGES OF ANY NATURE, INCLUDING WITHOUT LIMITATION, LOST REVENUES OR PROFITS, OR ANY OTHER DAMAGE WHETHER BASED IN CONTRACT, TORT, OR OTHERWISE.

Some states do not allow the exclusion or limitation of incidental or consequential damages or limitations on how long an implied warranty lasts, so the above exclusion or limitation may not apply to you. This warranty gives you specific legal rights and you may also have other rights that vary from state to state.

THIS LIMITED WARRANTY DOES NOT COVER:

- Service trips to deliver, pick up, or install or repair the product; instruction to the customer on operation of the product; repair or replacement of fuses or correction of wiring or plumbing, or correction of unauthorized repairs/installation.
- Failure of the product to perform during power failures and interrupted or inadequate electrical service.
- Damage caused by leaky or broken water pipes, frozen water pipes, restricted drain lines, inadequate or interrupted water supply or inadequate supply of air.
- Damage resulting from operating the product in a corrosive atmosphere or contrary to the instructions outlined in the product's owner's manual.
- Damage to the product caused by accidents, pests and vermin, lightning, wind, fire, floods, or acts of God.
- Damage or failure caused by unauthorized modification or alteration, or if it is used for other than the intended purpose, or any water leakage where the unit was not properly installed.
- Damage or failure caused by incorrect electrical current, voltage, or plumbing codes, commercial or industrial use, or use of accessories, components, or consumable cleaning products that are not approved by LG.
- Damage caused by transportation and handling, including scratches, dents, chips, and/or other damage to the finish of your product, unless such damage results from defects in materials or workmanship and is reported within one (1) week of delivery.
- Damage or missing items to any display, open box, discounted, or refurbished product.
- Conversion of product from natural gas or LP gas.

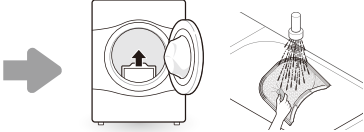
- Products with original serial numbers that have been removed, altered, or cannot be readily determined. Model and serial numbers, along with original retail sales receipts, are required for warranty validation.
- Increases in utility costs and additional utility expenses.
- Repairs when your product is used for other than normal and usual household use (e.g. commercial use, in offices and recreational facilities) or contrary to the instructions outlined in the product's owner's manual.
- Costs associated with removal of your product from your home for repairs.
- The removal and reinstallation of the product if it is installed in an inaccessible location or is not installed in accordance with published installation instructions, including LG's owner's and installation manuals.
- Damage resulting from misuse, abuse, improper installation, repair, or maintenance. Improper repair includes use of parts not approved or specified by LG.

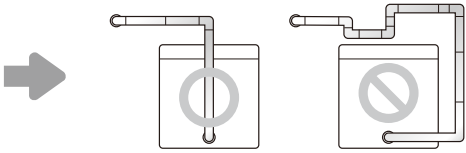
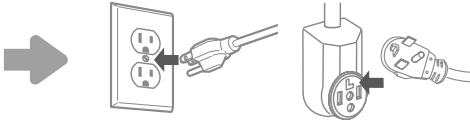
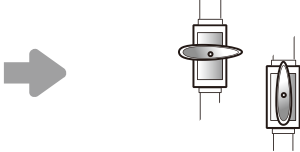
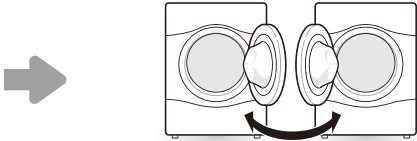
<p>Filter is clogged.</p> <p>Not heating, long dry time</p>		<p>Clean the lint filter.</p>
<p>Duct is clogged.</p> <p>Not heating, long dry time</p>		<p>Clean the hood and duct.</p>
<p>Excessive duct length and/or multiple elbows</p> <p>Not heating, long dry time</p>		<p>Keep exhaust ducts as short as possible, using as few elbows and bends as possible.</p>
<p>Improperly connected power cord or electrical outlet issue.</p> <p>No Power</p> <p>Not Heating</p>		<p>Reconnect power cord, replace house fuse or reset breaker. If outlet is issue, electrician may be required.</p>
<p>Gas valve is not turned on. (Gas Dryer)</p> <p>Not heating</p>		<p>Open the gas valve.</p>
<p>Door Reversal</p>		<p>Instructions for door reversal can be found in the owner's manual.</p>

The cost of repair or replacement under these excluded circumstances shall be borne by the consumer.

TO OBTAIN WARRANTY SERVICE AND ADDITIONAL INFORMATION

For additional product information, visit the LG website at <http://www.lg.com>

For assistance using this product or to schedule service, contact LG Electronics at 1-800-243-0000.

For further assistance, write: LG Electronics, 201 James Record Road, Huntsville, Alabama 35813

PROCEDURE FOR RESOLVING DISPUTES:

ALL DISPUTES BETWEEN YOU AND LG ARISING OUT OF OR RELATING IN ANY WAY TO THIS LIMITED WARRANTY OR THE PRODUCT SHALL BE RESOLVED EXCLUSIVELY THROUGH BINDING ARBITRATION, AND NOT IN A COURT OF GENERAL JURISDICTION. BINDING ARBITRATION MEANS THAT YOU AND LG ARE EACH WAIVING THE RIGHT TO A JURY TRIAL AND TO BRING OR PARTICIPATE IN A CLASS ACTION.

Definitions. For the purposes of this section, references to “LG” mean LG Electronics U.S.A., Inc., its parents, subsidiaries and affiliates, and each of their officers, directors, employees, agents, beneficiaries, predecessors in interest, successors, assigns and suppliers; references to “dispute” or “claim” shall include any dispute, claim or controversy of any kind whatsoever (whether based in contract, tort, statute, regulation, ordinance, fraud, misrepresentation or any other legal or equitable theory) arising out of or relating in any way to the sale, condition or performance of the product or this Limited Warranty.

Notice of Dispute. In the event you intend to commence an arbitration proceeding, you must first notify LG in writing at least 30 days in advance of initiating the arbitration by sending a letter to LG at LG Electronics, USA, Inc. Attn: Legal Department- Arbitration 111 Sylvan Ave, Englewood Cliffs, NJ 07632. You and LG agree to engage in good faith discussions in an attempt to amicably resolve your claim. The notice must provide your name, address, and telephone number; identify the product that is the subject of the claim; and describe the nature of the claim and the relief being sought. If you and LG are unable to resolve the dispute within 30 days, either party may proceed to file a claim for arbitration.

Agreement to Binding Arbitration and Class Action Waiver. Upon failure to resolve the dispute during the 30 day period after sending written notice to LG, you and LG agree to resolve any claims between us only by binding arbitration on an individual basis, unless you opt out as provided below. Any dispute between you and LG shall not be combined or consolidated with a dispute involving any other person’s or entity’s product or claim. More specifically, without limitation of the foregoing, any dispute between you and LG shall not under any circumstances proceed as part of a class or representative action. Instead of arbitration, either party may bring an individual action in small claims court, but that small claims court action may not be brought on a class or representative basis.

Arbitration Rules and Procedures. To begin arbitration of a claim, either you or LG must make a written demand for arbitration. The arbitration will be administered by the American Arbitration Association (“AAA”) and will be conducted before a single arbitrator under the AAA’s Consumer Arbitration Rules that are in effect at the time the arbitration is initiated (referred to as the “AAA Rules”) and under the procedures set forth in this section. The AAA Rules are available online at www.adr.org/consumer. Send a copy of your written demand for arbitration, as well as a copy of this provision, to the AAA in the manner described in the AAA Rules. You must also send a copy of your written demand to LG at LG Electronics, USA, Inc. Attn: Legal Department- Arbitration 111 Sylvan Avenue, Englewood Cliffs, NJ 07632. If there is a conflict between the AAA Rules and the rules set forth in this section, the rules set forth in this section will govern. This arbitration provision is governed by the Federal Arbitration Act. Judgment may be entered on the arbitrator’s award in any court of competent jurisdiction. All issues are for the arbitrator to decide, except that issues relating to the scope and enforceability of the arbitration provision and to the arbitrability of the dispute are for the court to decide. The arbitrator is bound by the terms of this provision.

Governing Law. The law of the state of your residence shall govern this Limited Warranty and any disputes between us except to the extent that such law is preempted by or inconsistent with applicable federal law.

Fees/Costs. You do not need to pay any fee to begin an arbitration. Upon receipt of your written demand for arbitration, LG will promptly pay all arbitration filing fees to the AAA unless you seek more than \$25,000 in damages, in which case the payment of these fees will be governed by the AAA Rules. Except as otherwise provided for herein, LG will pay all AAA filing, administration and arbitrator fees for any arbitration initiated in accordance with the AAA Rules and this arbitration provision. If you prevail in the arbitration, LG will pay your attorneys’ fees and expenses as long as they are reasonable, by considering factors including, but not limited to, the purchase amount and claim amount. Notwithstanding the foregoing, if applicable law allows for an award of reasonable attorneys’ fees and expenses, an arbitrator can award them to the same extent that a court would. If the arbitrator finds either the substance of your claim or the relief sought in the demand is frivolous or brought for an improper purpose (as measured by the standards set forth in Federal Rule of Civil Procedure 11(b)), then the payment of all arbitration fees will be governed by the AAA Rules. In such a situation, you agree to reimburse LG for all monies previously disbursed by it that are otherwise your obligation to pay under the AAA Rules. Except as otherwise provided for, LG waives any rights it may have to seek attorneys’ fees and expenses from you if LG prevails in the arbitration.

Hearings and Location. If your claim is for \$25,000 or less, you may choose to have the arbitration conducted solely on the basis of (1) documents submitted to the arbitrator, (2) through a telephonic hearing, or (3) by an in-person hearing as established by the AAA Rules. If your claim exceeds \$25,000, the right to a hearing will be determined by the AAA Rules. Any in-person arbitration hearings will be held at a location within the federal judicial district in which you reside unless we both agree to another location or we agree to a telephonic arbitration.

Opt Out. You may opt out of this dispute resolution procedure. If you opt out, neither you nor LG can require the other to participate in an arbitration proceeding. To opt out, you must send notice to LG no later than 30 calendar days from the date of the first consumer purchaser's purchase of the product by either: (i) sending an e-mail to optout@lge.com, with the subject line: "Arbitration Opt Out" or (ii) calling 1-800-980-2973. You must include in the opt out e-mail or provide by telephone: (a) your name and address; (b) the date on which the product was purchased; (c) the product model name or model number; and (d) the serial number (the serial number can be found (i) on the product; or (ii) online by accessing <https://www.lg.com/us/support/repair-service/schedule-repair-continued> and clicking on "Find My Model & Serial Number").

You may only opt out of the dispute resolution procedure in the manner described above (that is, by e-mail or telephone); no other form of notice will be effective to opt out of this dispute resolution procedure. Opting out of this dispute resolution procedure will not affect the coverage of the Limited Warranty in any way, and you will continue to enjoy the full benefits of the Limited Warranty. If you keep this product and do not opt out, then you accept all terms and conditions of the arbitration provision described above.





OWNER'S MANUAL

WASHING MACHINE

Read this owner's manual thoroughly before operating the appliance and keep it handy for reference at all times.

ENGLISH

WM3600H*A



MFL71693706
Rev.00_061220

www.lg.com

Copyright © 2020 LG Electronics Inc. All Rights Reserved.

TABLE OF CONTENTS

3 IMPORTANT SAFETY INSTRUCTIONS

- 3 READ ALL INSTRUCTIONS BEFORE USE
- 3 WARNING STATEMENTS
- 6 CAUTION STATEMENTS

7 PRODUCT OVERVIEW

- 7 Product Features

9 INSTALLATION

- 9 Before Installing
- 10 Choosing the Proper Location
- 11 Unpacking and Removing Shipping Material
- 12 Connecting the Water Inlet Hoses
- 13 Connecting the Drain Hose
- 14 Leveling the Washer
- 15 Final Installation Check

17 OPERATION

- 17 Before Use
- 18 Sorting Laundry
- 19 Loading the Washer
- 20 Adding Cleaning Products
- 23 Control Panel
- 25 Wash Cycles
- 28 Cycle Modifiers
- 28 Options and Extra Functions

31 SMART FUNCTIONS

- 31 Using LG ThinQ Application
- 33 Smart Diagnosis™ Function

35 MAINTENANCE

- 35 Regular Cleaning
- 35 Periodic Maintenance
- 39 Care in Cold Climates

41 TROUBLESHOOTING

- 41 Before Calling for Service

49 LIMITED WARRANTY

- 49 USA
- 52 CANADA

IMPORTANT SAFETY INSTRUCTIONS

READ ALL INSTRUCTIONS BEFORE USE

Safety Messages

Your safety and the safety of others are very important.

We have provided many important safety messages in this manual and on your appliance. Always read and follow all safety messages.



This is the safety alert symbol.

This symbol alerts you to potential hazards that can kill or injure you and others. All safety messages will follow the safety alert symbol and either the word **WARNING** or **CAUTION**.

These words mean:



WARNING

You may be killed or seriously injured if you do not follow instructions.



CAUTION

You may be injured or cause damage to the product if you do not follow instructions.

All safety messages will tell you what the potential hazard is, tell you how to reduce the chance of injury, and tell you what may happen if the instructions are not followed.

WARNING STATEMENTS



WARNING

- To reduce the risk of explosion, fire, death, electric shock, scalding or injury to persons when using this product, follow basic precautions, including the following:

Installation

- Adhere to all industry recommended safety procedures including the use of long-sleeved gloves and safety glasses.
- Never attempt to operate this appliance if it is damaged, malfunctioning, partially disassembled, or has missing or broken parts, including a damaged cord or plug.
- Before use, the appliance must be properly installed as described in this manual.
- To reduce the risk of severe injury or death, follow all installation instructions.
- Refer to the **INSTALLATION INSTRUCTIONS** for detailed grounding procedures. Installation instructions are packed with the appliance for the installer's reference. If the appliance is moved to a new location, have it checked and reinstalled by qualified service personnel.
- Moving or installation of the appliance requires two or more people.
- Do not install the appliance in humid spaces.
- Store and install the appliance where it will not be exposed to temperatures below freezing or exposed to outdoor weather conditions.
- This appliance is not designed for maritime use or for mobile installations such as in RVs, trailers, or aircraft.
- Keep packing materials out of the reach of children. Packaging material can be dangerous for children. There is a risk of suffocation.

4 IMPORTANT SAFETY INSTRUCTIONS

- Destroy the carton, plastic bag, and other packing materials after the appliance is unpacked. Children might use them for play. Cartons covered with rugs, bedspreads, or plastic sheets can become airtight chambers.
- The appliance must be installed and electrically grounded by qualified service personnel in accordance with local codes.
- When installing or moving the appliance, be careful not to pinch, crush, or damage the power cord.
- Connect to a properly rated, protected, and sized power circuit to avoid electrical overload.
- This appliance must be positioned near to an electrical power supply.
- Disconnect the power cord, house fuse or circuit breaker before installing or servicing the appliance.
- The power cord of this appliance is equipped with a 3-prong (grounding) plug which mates with a standard 3-prong (grounding) wall outlet to minimize the possibility of electric shock from this appliance.
- Do not, under any circumstances, cut or remove the third (ground) prong from the power cord.
- Use new hoses when connecting the washer to the water supply. Do not reuse old hoses.

Operation

- Read all instructions before using the appliance and save these instructions.
- Use this appliance only for its intended purpose.
- If the product has been submerged in water, sitting in standing water, or waterlogged, do not come in contact with the product and immediately contact an LG Electronics Customer Information Center for instructions before resuming use.
- If you detect a strange sound, a chemical or burning smell, or smoke coming from the appliance, unplug it immediately, and contact an LG Electronics Customer Information Center.
- Under certain conditions, hydrogen gas may be produced in a hot-water system that has not been used for two weeks or more. HYDROGEN GAS IS EXPLOSIVE. If the hot-water system has not been used for such a period, before using the appliance, turn on all hot water faucets and let the water flow from each for several minutes. This will release any accumulated hydrogen gas. As the gas is flammable, do not smoke or use an open flame during this time.
- Do not reach into the washer if the tub or drum, agitator, or any interior parts are moving. Before loading, unloading, or adding items, press Start/Pause and allow the tub or drum to coast to a complete stop before reaching inside.
- This appliance is not intended for use by persons (including children) with reduced physical, sensory or mental capabilities, or lack of experience and knowledge, unless they have been given supervision or instruction concerning the use of the appliance by a person responsible for their safety.
- Do not allow children or pets to play on, in or with the appliance. Close supervision is necessary when the appliance is used near children or pets.
- Keep laundry products out of children's reach. To prevent injury to persons, observe all warnings on product labels.
- Repair or immediately replace all power cords that have become frayed or otherwise damaged. Do not use a cord that shows cracks or abrasion damage along its length or at either end.
- Never unplug the appliance by pulling on the power cord. Always grip the plug firmly and pull straight out from the outlet.
- Do not use an extension cord or adapter with this appliance.
- Do not grasp the power cord or touch the appliance controls with wet hands.
- Do not modify or extend the power cord.
- If the electrical supply cord is damaged, it must only be replaced by the manufacturer or its service agent or a similar qualified person in order to avoid a hazard.
- Do not put oily or greasy clothing, candles or flammable materials on top of the appliance.
- Keep the area underneath and around your appliances free of combustible materials (lint, paper, rags, etc.), gasoline, chemicals and other flammable vapors and liquids.

- Do not store or use gasoline or other flammable vapors and liquids in the vicinity of this or any other appliance.
- Do not mix chlorine bleach with ammonia or acids such as vinegar. Follow package directions when using laundry products. Incorrect usage can produce poisonous gas, resulting in serious injury or death.
- Never use harsh chemicals, abrasive cleaners, or solvents to clean the washer. They will damage the finish.
- Do not wash laundry that has been previously cleaned in, washed in, soaked in, or spotted with gasoline, dry-cleaning solvents, vegetable or cooking oil, or other flammable or explosive substances, as they give off vapors that could ignite or explode.
- Do not add gasoline, dry cleaning solvents, or other flammable or explosive substances to the wash water. These substances give off vapors that could ignite or explode.
- In the event of a gas leak (propane gas, LP gas, etc.), do not operate this or any other appliance. Open a window or door to ventilate the area immediately.
- Do not tamper with controls.
- Fix the drain hose securely in place to avoid flooding.
- Do not abuse, sit on, or stand on the door of the appliance.
- Always check the inside of the appliance for foreign objects.
- Do not allow water, bleach or other liquids to sit in the drum for extended periods. Doing so can corrode the drum or cause mildew or odors.

Maintenance

- Do not repair or replace any part of the appliance. All repairs and servicing must be performed by qualified service personnel unless specifically recommended in this owner's manual. Use only authorized factory parts.
- Disconnect this appliance from the power supply before cleaning and attempting any user maintenance. Turning the controls to the OFF position does not disconnect this appliance from the power supply.
- Remove any dust or foreign matter from the power plug pins.
- Do not disassemble or repair the appliance by yourself.
- Remove the door before the appliance is removed from service or discarded to avoid the danger of children or small animals getting trapped inside.
- Make sure the dispenser drawer or lid is closed at all times when not being filled with laundry products.

Grounding Instructions

- Improper connection of the equipment-grounding conductor can result in a risk of electric shock. Check with a qualified electrician or service personnel if you are in doubt whether the appliance is properly grounded. Do not modify the plug provided with the appliance; if it will not fit the outlet, have a proper outlet installed by a qualified electrician.
- The appliance must be grounded. In the event of a malfunction or breakdown, grounding will reduce the risk of electric shock by providing a path of least resistance for electric current. The appliance is equipped with a cord having an equipment-grounding conductor and a grounding plug. The plug must be plugged into an appropriate outlet that is installed and grounded in accordance with all local codes and ordinances.

CAUTION STATEMENTS

CAUTION

- To reduce the risk of minor or moderate injury to persons, malfunction, or damage to the product or property when using this product, follow basic precautions, including the following:
-

Installation

- Install the product on a firm and level floor.

Operation

- Do not place objects on top of the appliance.
- Turn off the water faucets and unplug the appliance if the appliance is to be left for an extended period of time, such as during vacations.
- ALWAYS follow the fabric care instructions supplied by the garment manufacturer.
- Use fabric softeners or products to eliminate static only as recommended by the manufacturer.
- Do not combine laundry products for use in one load unless specified on the label.
- Do not touch draining water which may be hot.
- If the drain hose and the water inlet hose are frozen in winter, defrost them before using the appliance.
- Do not store or spill liquid detergents, cleaners, or bleaches (chlorine bleach, oxygen bleach) on the appliance. Doing so may result in corrosion, discoloration or damage to the surface of the appliance.
- Clothing or articles that are waterproof or water resistant must be washed in the Waterproof cycle only. (Examples include water resistant clothing, mattress covers, outdoor clothes, plastic mats.) Using another cycle may result in personal injury or damage to the washer, clothes, walls, floor, and surrounding objects due to abnormal vibration.

SAVE THESE INSTRUCTIONS

PRODUCT OVERVIEW

Product Features

The images in this guide may be different from the actual components and accessories, which are subject to change by the manufacturer without prior notice for product improvement purposes.

⚠ WARNING

- For your safety and for extended product life, use only authorized components. The manufacturer is not responsible for product malfunction, property damage or bodily injury caused by the use of separately purchased unauthorized components, parts, or non-LG products.

Front View

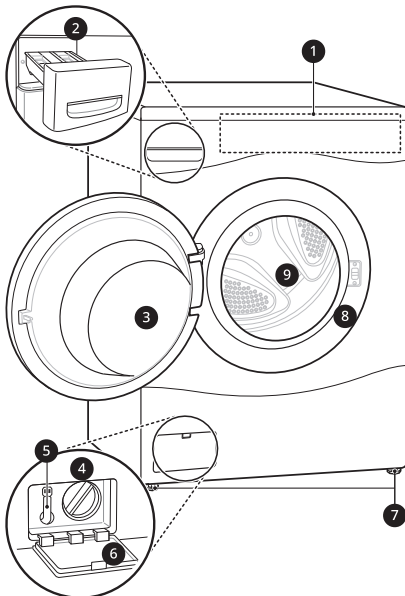

- ❶ Control Panel
- ❷ Detergent Dispenser Drawer
- ❸ Door
- ❹ Drain Pump Filter
- ❺ Drain Hose
- ❻ Drain Pump Filter Cover
- ❼ Leveling Feet
- ❽ Door Seal
- ❾ Drum

Rear View

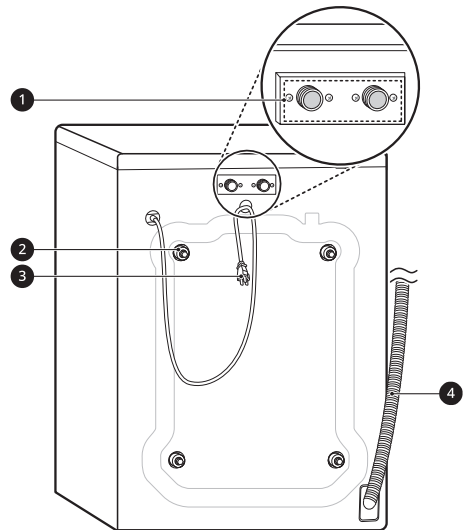

- ❶ Water Inlets
- ❷ Shipping Bolts
- ❸ Power Cord
- ❹ Drain Hose

Accessories

Included Accessories

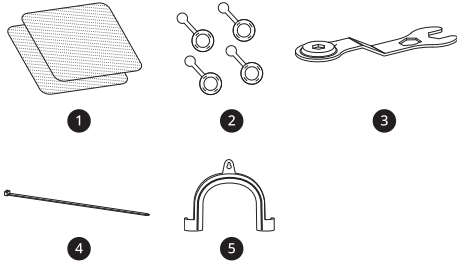

- ❶ Non-skid Pads
- ❷ Hole Caps
- ❸ Wrench
- ❹ Tie Strap
- ❺ Elbow Bracket (for securing drain hose)

Required Accessories

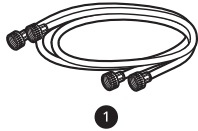

- ❶ Hot and Cold Water Hoses

Optional Accessories

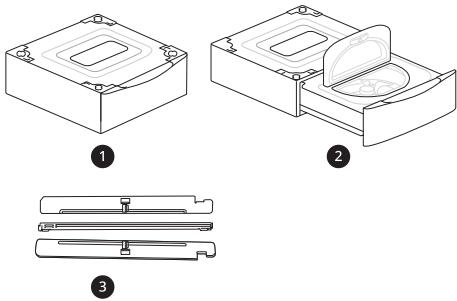

- ❶ Pedestal
- ❷ Pedestal Washer
- ❸ Stacking Kit

Product Specifications

Model	WM3600H*A
Electrical Requirements	120 VAC @ 60 Hz
Min. / Max. Water Pressure	20 - 120 psi (138 - 827 kPa)
Dimensions (Width X Height X Depth)	27" X 39" X 30 1/4" (70 cm X 99 cm X 77 cm)
Maximum Depth with Door Open	55" (139.6 cm)
Net Weight	198.4 lb (90 kg)
Max. Spin Speed	1300 RPM

INSTALLATION

Before Installing

Installation Overview

Please read the following installation instructions first after purchasing this washer or transporting it to another location.

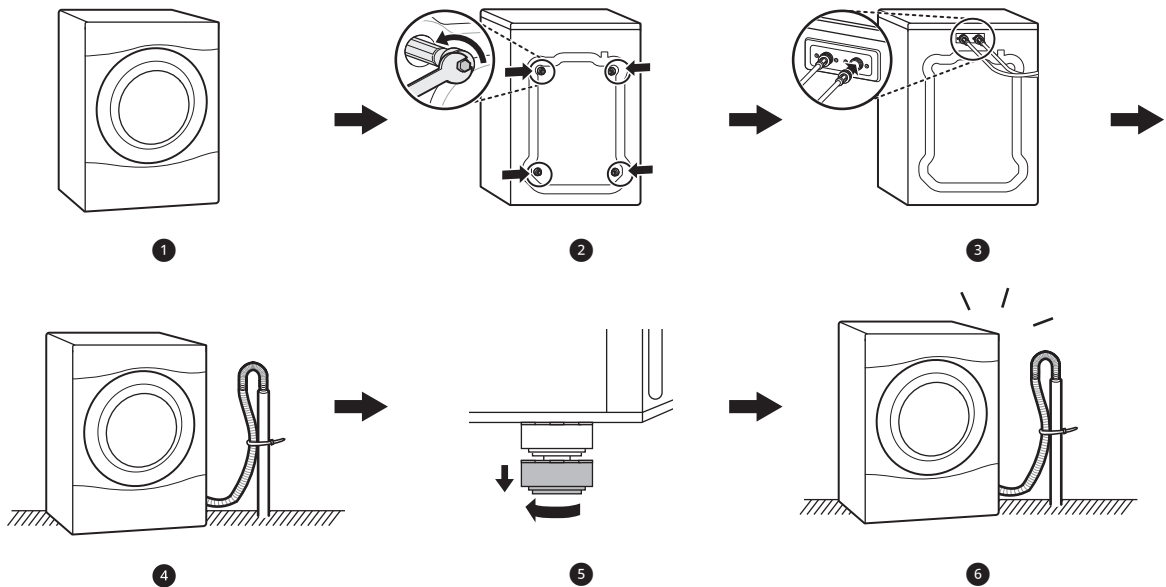

- ❶ Choosing the Proper Location
- ❷ Unpacking and Removing Shipping Material
- ❸ Connecting the Inlet Hoses
- ❹ Connecting the Drain Hose
- ❺ Leveling the Washer
- ❻ Final Installation Check

⚠ WARNING

- Moving or installation of the appliance requires two or more people. Failure to follow these instructions may result in injury.
- Store and install the appliance where it will not be exposed to temperatures below freezing or exposed to outdoor weather conditions. Failure to follow this warning can cause product or part failure, serious injury, fire, electric shock, or death.
- Properly ground the washer to conform with all governing codes and ordinances. Failure to follow this warning can cause serious injury, fire, electric shock, or death.
- To ensure proper airflow, do not block the large opening on the bottom of the washer with carpeting or other materials.
- Do not remove the ground prong from the power cord. Do not use an adapter or extension cord. Plug into a grounded 3-prong outlet. Failure to follow this warning can cause serious injury, fire, electric shock, or death.

⚠ WARNING

- Certain internal parts are intentionally not grounded and may present a risk of electric shock only during servicing. Service personnel- Do not contact the following parts while the appliance is energized: pump, valve, motor, control board.

Tools Needed

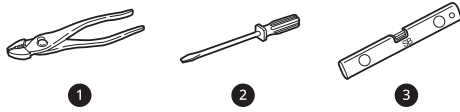

- ❶ Pliers
- ❷ Flat-Blade Screwdriver
- ❸ Level

Choosing the Proper Location

Check the following requirements for the install location before installing the washer.

- Allow for sufficient space between the walls and the washer for installation.
- Make sure that the floor is clean, dry and free of dust, dirt, water and oil so the leveling feet cannot slide easily. Leveling feet that can move or slide on the floor can contribute to excess vibration and noise.
- If the floor has too much flex, reinforce it to make it more rigid. If the floor is not solid, it may cause severe vibration and noise.
- If a drain pan must be used, take extra care to follow the instructions provided with the drain pan and make sure the leveling feet are adjusted for firm and even contact with the pan. Use of drain pans and failure to properly level the washer may result in increased vibration and noise during operation.

Power Outlet

- The power outlet must be within **60 inches (1.5 m)** of either side of the washer.
- Position the washer so that the outlet and plug are easily accessible.
- Do not overload the outlet with more than one appliance.
- The outlet must be grounded in accordance with current electrical wiring codes and regulations.
- Use a time-delay fuse or circuit breaker.

- It is the personal responsibility and obligation of the washer owner to have a proper outlet installed by a qualified electrician.

Flooring

- To minimize noise and vibration, install the washer on a level, solidly constructed floor capable of supporting the washer without flexing or bouncing.
- The washer must be installed on firm flooring to minimize vibration during the spin cycle. Concrete flooring is best, but a wood floor is sufficient, provided it is built to FHA standards.
- The floor under the washer must not slope more than 1 inch (2.5 cm) from front to back or side to side.
- Installing on carpeting and soft tile surfaces is not recommended.
- Never install the washer on a platform or weakly supported structure.

Floor Installation

To ensure sufficient clearance for water inlet hoses, drain hose and airflow, allow minimum clearances of at least **1 inch (2.5 cm)** at the sides and **4 inches (10 cm)** behind the washer. Be sure to allow for wall, door, or floor moldings that may increase the required clearances.

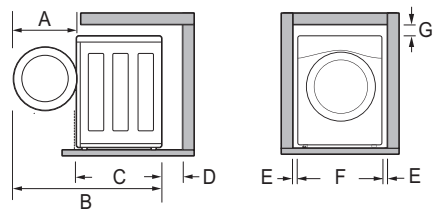

Dimensions and Clearances	
A	24 3/4" (62.6 cm)
B	55" (139.6 cm)
C	30 1/4" (77 cm)
D	4" (10 cm)
E	1" (2.5 cm)

Dimensions and Clearances	
F	27" (70 cm)
G	1/4" (0.5 cm)

Stacking or Pedestal Installation

The washer can be stacked under a dryer or on top of a pedestal or pedestal washer.

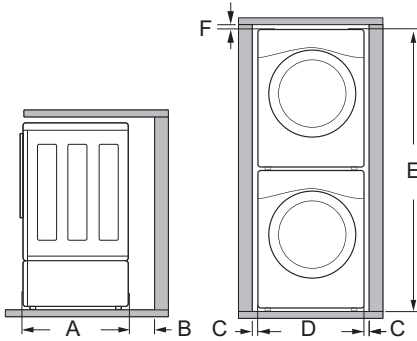

Dimensions and Clearances	
A	30 1/4" (77 cm)
B	4" (10 cm)
C	1" (0.5 cm)
D	27" (70 cm)
E	77 1/2" (196.8 cm)
F	1/4" (0.5 cm)

NOTE

- Refer to the instructions packaged with the optional pedestal kit before stacking appliance on pedestal.
- Do not use a drain pan with a pedestal or pedestal washer installation as it can block the drawer. Using a drain pan may result in increased vibration and noise during operation.

Unpacking and Removing Shipping Material

Remove all shipping materials from the washer for proper operation and inspect it for shipping damage.

CAUTION

- Failure to remove shipping materials can cause excessive noise and vibration.

Unpacking Shipping Material

* This feature is only available on some models.

Lift the washer off the foam base.

- After removing the carton and shipping material, lift the washer off the foam base.
- Make sure the plastic drum support **1*** comes off with the base and is not stuck to the bottom of the washer.
- If you must lay the washer down to remove the carton base **2**, always protect the side of the washer and lay it carefully on its side. Do not lay the washer on its front or back.

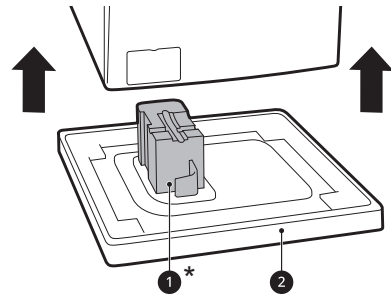

Removing Shipping Material

- 1 Remove the bolt assemblies.
 - Starting with the bottom two shipping bolts **3**, use the included wrench to fully loosen all 4 shipping bolts by turning them counterclockwise.
 - Remove the bolt assemblies (bolts and retainers) by wiggling them slightly while pulling them out.

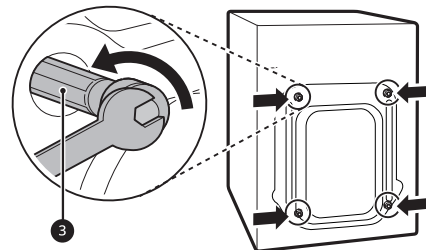

- 2 Install the hole caps.
 - Locate the hole caps **4** included in the accessory pack or attached to the back of

the washer. Install the caps in the holes left by the bolt assemblies.

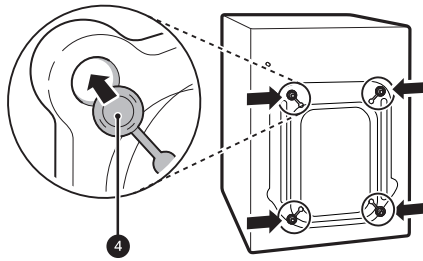

CAUTION

- Once removed, save the bolt assemblies for future use. To prevent damage to internal components, do not transport the washer without reinstalling the shipping bolts. Failure to remove shipping bolts and retainers may cause severe vibration and noise, which can lead to permanent damage to the washer.

NOTE

- The power cord is secured to the back of the washer with a shipping bolt to help prevent operation with shipping bolts in place.

Connecting the Water Inlet Hoses

To avoid the risk of costly water damage, purchase and install new water inlet hoses when installing the washer.

WARNING

- Do not overtighten the hoses or cross-thread the hose fittings. Overtightening or cross-threading can damage the valves or couplings, resulting in leaking and property damage.
- Do not reuse old hoses. Use only new hoses when installing the washer. Old hoses could leak or burst causing flooding and property damage. Contact an LG Customer Information Center for assistance in buying hoses.

NOTE

- Periodically check the hoses for cracks, leaks, and wear, and replace the hoses every five years.
- Do not stretch the water hoses intentionally, and make sure that they are not pinched, crushed or kinked by other objects.

- Water supply pressure must be between **20 psi** and **120 psi (138 - 827 kPa)**. If the water supply pressure is more than **120 psi**, a pressure reducing valve must be installed.
- Your hot water heater should be set to deliver water at **120–135 °F (48–57 °C)** to allow the washer to properly control wash temperatures.
- Do not store or install the washer in a location subject to freezing temperatures. Damage to the water inlet hoses and internal mechanisms of the washer can result. If the washer was exposed to freezing temperatures prior to installation, allow it to stand at room temperature for several hours before use and check for leaks prior to operation.
- Do not use flood-preventing hoses with auto shut off devices. The devices can be tripped during fill and prevent the washer from filling properly.

How to Connect the Water Inlet Hoses

- 1 Check the fittings and seals. Inspect the threaded fitting on each hose and make sure there is a rubber seal **1** in place in both ends of each hose to prevent leaking.

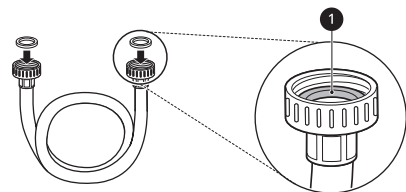

- 2 Connect the water supply hoses.
 - Connect the water inlet hoses to the hot and cold water faucets tightly by hand and then tighten another 2/3 turn with pliers.
 - Connect the blue hose to the cold water faucet and the red hose to the hot water faucet.

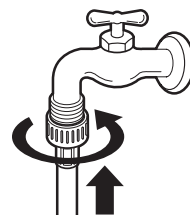

- 3 Flush out the inlet hoses.
 - After the hoses are connected, turn on the water faucets and flush out any foreign substances such as dirt, sand, or sawdust.

- Let the water drain into a bucket, and check the water temperature to make sure you've connected the hoses to the correct faucets.



- 4** Attach the inlet hoses to the back of the washer.
- Attach the hot water inlet hose to the hot water inlet on the back of the washer. Attach the cold water inlet hose to the cold water inlet on the back of the washer.
 - Tighten the fittings securely. Turn on both faucets all the way and check for leaks at both ends of the hoses.

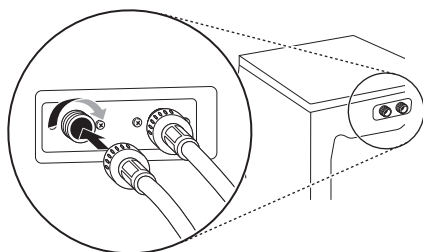

Connecting the Drain Hose

Connect the drain hose to either a standpipe or laundry tub.

⚠ WARNING

- The drain hose should always be properly secured. Failure to properly secure the drain hose can result in flooding and property damage.

NOTE

- The drain must be installed in accordance with any applicable local codes and regulations.
- Make sure that the drain hose is not stretched, pinched, crushed, or kinked.
- Do not install the drain hose with the end lower than **29.5 inches (75 cm)** or higher than **96 inches (244 cm)** above the bottom of the washer or more than **60 inches (152 cm)** away from the washer.

- Never create an airtight seal between the hose and the drain with tape or other means. If no air gap is present, water can be siphoned out of the drum resulting in poor wash/rinse performance or clothing damage.

Using a Standpipe to Drain

- 1** Clip the end of the hose into the elbow bracket.
- Connect the elbow bracket **1** within **4 inches (10 cm)** of the end of the drain hose. If the drain hose is extended more than **4 inches (10 cm)** beyond the end of the elbow bracket, mold or microorganisms could spread to the inside of the washer.

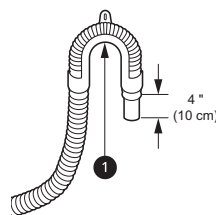

- 2** Insert the end of the drain hose into the standpipe.

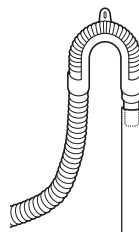

- 3** Use the provided tie strap **2** to secure the drain hose in place.

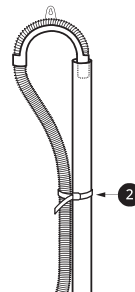

- 4** If the water valves and drain are built into the wall, fasten the drain hose to one of the water hoses with the provided tie strap **3** (ribbed side on inside).

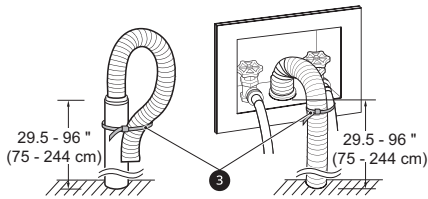

Using the Laundry Tub to Drain

- 1 Clip the end of the hose into the elbow bracket.
 - Connect the elbow bracket ① within **4 inches (10 cm)** of the end of the drain hose. If the drain hose is extended more than **4 inches (10 cm)** beyond the end of the elbow bracket, mold or microorganisms could spread to the inside of the washer.

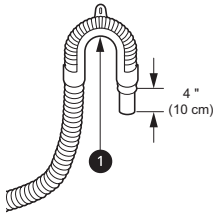

- 2 Hang the end of the drain hose over the side of the laundry tub.

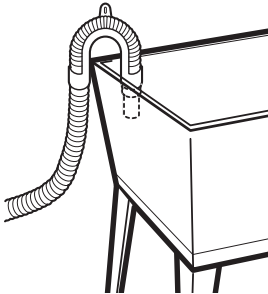

- 3 Use the provided tie strap to secure the drain hose in place.

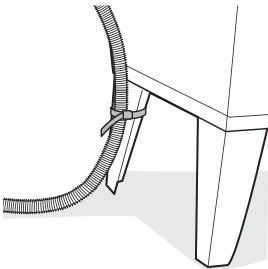

Leveling the Washer

The drum of the washer spins at very high speeds. To minimize vibration, noise, and unwanted movement, the floor must be a solid, level surface.

CAUTION

- Using the washer without leveling it may cause excess vibration and noise, leading to a washer malfunction.
- Adjust the leveling feet only as far as necessary to level the washer. Extending the leveling feet more than necessary can cause the washer to vibrate.

NOTE

- Before installing the washer, make sure that the floor is clean, dry and free of dust, dirt, water and oil so the washer feet cannot slide easily. Feet that move or slide on the floor can contribute to excessive vibration and noise.

How to Level the Washer

- 1 Position the washer in its final location.
 - Take special care not to pinch, strain, or crush the water and drain hoses. If you have a carpenter's level ①, you can use it to check that the washer is level. The slope beneath the washer should not exceed **1 inch**, and all 4 leveling feet must rest firmly on the floor.

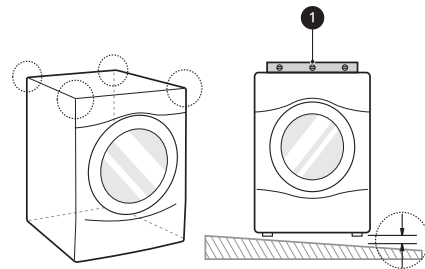

- 2** Adjust the leveling feet.
- Turn all 4 leveling feet in one direction to raise the washer or the other direction to lower it.

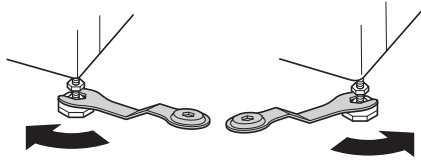

- 3** Check the level again.
- Push or rock the top edges of the washer gently to make sure the washer does not rock. If the washer rocks, readjust the leveling feet.

- 4** Tighten the locknuts **2**
- Turn the locknuts counterclockwise and tighten them when the washer is level.

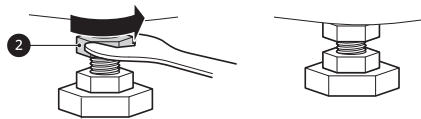

Using Non-Skid Pads

If you install the washer on a slippery surface, it may move because of excessive vibration. Incorrect leveling may cause malfunction through noise and vibration. If this occurs, install the non-skid pads under the leveling feet and adjust the level.

- 1** Clean the floor to attach the non-skid pads.
 - Use a dry rag to remove and clean foreign objects or moisture. If moisture remains, the non-skid pads may slip.
- 2** Adjust the level after placing the washer in the installation area.
- 3** Place the adhesive side **3** of the non-skid pad on the floor.
 - It is most effective to install the non-skid pads under the front leveling feet. If it is hard to place the pads under the front

leveling feet, place them under the back leveling feet.

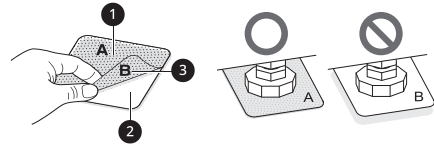

- 1** This side up
- 2** Remove backing

- 4** Recheck the washer's levelness.
- Push or rock the top edges of the washer gently to make sure the washer does not rock. If the washer rocks, level the washer again.

Final Installation Check

Connecting to the Power Supply

Plug the washer into a **120 VAC, 60 Hz** grounded 3-prong outlet.

WARNING

- Do not use a worn or damaged power cord or power plug. Replace or repair it immediately. Failure to do so may result in death, fire, electric shock, or malfunction.
- Do not modify the power cord and plug provided with the appliance. Do not damage it when installing or moving the appliance. Doing so may result in death, fire, electric shock, or malfunction.
- Make sure that the appliance is grounded.
- Connect this appliance to a grounded outlet conforming to the rating prior to use. Failure to do so may result in fire, electric shock, or malfunction.
- Do not damage or cut off the ground prong of the power cord. Doing so may cause death, fire, electric shock, or product malfunction.
- Improper connection of the equipment grounding conductor can result in risk of electric shock. Check with a qualified electrician or service technician if you are in doubt as to whether the appliance is properly grounded. If the plug does not fit the outlet, have a proper outlet installed by a qualified electrician.
- The appliance and outlet must be positioned so that the plug is easily accessible.

WARNING

- Do not use an adapter or extension cord. Doing so may result in serious injury, fire, electric shock, or death.
 - For best performance, plug the appliance into its own individual outlet. This helps prevent overloading house wiring circuits which could cause a fire hazard from overheated wires.
 - If necessary, use a new, UL-listed 3-prong (grounding) plug rated at no less than the branch circuit. Do not use an extension cord longer than 3 feet. Failure to follow these warnings may result in serious injury, fire, electric shock, or death.
-

Testing the Washer

Check if the washer is properly installed and run a test cycle.

- 1** Load the washer with 6 thick bath towels (approximately 6 pounds).
- 2** Press the **Power** button.
- 3** Select the **Rinse+Spin** cycle.
- 4** Press the **Start/Pause** button to start the wash cycle.
- 5** Make sure that water is supplied, that the washer does not rock or vibrate excessively, and that it drains well during the spin cycle.

NOTE

- If water leaks during water supply, see **Connecting the Water Inlet Hoses** to connect them properly.
 - If the washer rocks and vibrates excessively, see **Leveling the Washer** to level it again.
 - If the drain does not work, see **Connecting the Drain Hose** to install the hose properly.
-

OPERATION

Before Use

WARNING

- To reduce the risk of fire, electric shock, or injury to persons, read the SAFETY INSTRUCTIONS before operating this appliance.

Operation Overview

- 1** Sort laundry and load the washer.
 - Sort laundry by fabric type, soil level, color and load size, as needed. Open the door and load items into the washer.
 - If using single-use detergent packs, place pack into the drum before loading the laundry.
- 2** Add cleaning products.
 - Add the proper amount of HE (High-Efficiency) detergent to the detergent dispenser.
 - If desired, add bleach or fabric softener to the appropriate areas of the dispenser drawer.
 - Do not place liquid or powdered detergent packs in the dispenser.
- 3** Turn on the washer.
 - Press the **Power** button to turn on the washer.
- 4** Select a cycle.
 - Turn the cycle selector knob or press the cycle buttons repeatedly until the desired cycle is selected.
 - The preset wash temperature, spin speed, soil level and option settings for the selected cycle are shown.
 - The **Normal** cycle must be selected in order to change its default settings.
 - Pressing the **Start/Pause** button without selecting a cycle immediately starts the **Normal** cycle with the default settings.
- 5** Adjust settings.
 - Default settings for the selected cycle can be changed, if desired, using the cycle modifier and option buttons.
 - Not all modifiers and options are available on all cycles. A different chime sounds and the LED does not light up if the selection is not allowed.
- 6** Begin cycle.
 - Press the **Start/Pause** button to begin the cycle. The door locks, and the washer agitates briefly without water to measure the weight of the load.
 - If the **Start/Pause** button is not pressed within a certain time, the washer shuts off and all settings are lost.
- 7** End of cycle.
 - When the cycle is finished, a melody sounds. Immediately remove the clothing from the washer to reduce wrinkling.

18 OPERATION

- Check around the door seal when removing the load for small items that may be caught in the seal.

NOTE

- The washer rotates the laundry in a way that allows it to use less water while still fully saturating the clothing. It is normal to be unable to see water during the wash cycle.
 - If the temperature or the water level inside the machine is too high, the door will not unlock when the **Start/Pause** button is pressed, and the **Add Item** function will not be available (on applicable models). To stop a cycle and drain the water completely, turn the power off, then on, and then select the **Rinse+Spin**.
-

Sorting Laundry

CAUTION

- Clothing or articles that are waterproof or water-resistant must be washed in the **Bedding** cycle only. (Examples include water resistant clothing, mattress covers, outdoor clothes, and plastic mats.) Failure to do so may result in personal injury or damage to the washer, clothes, walls, floor, and surrounding objects due to abnormal vibration.
 - Remove the stuffing from pillows and cushions before washing the covers. Failure to do so can cause excessive vibration, resulting in damage to the washer, clothes, nearby objects, walls, and floor.
-

Grouping Similar Items

For the best washing results, and to reduce the possibility of damage to clothing, sort clothing into loads made up of similar items.

Mixing different fabric types and/or soil levels can result in poor wash performance, color transfer, discoloration, fabric damage or linting. Fabrics should be sorted into groups as described below.

Colors

Sort articles by color. Wash dark clothes separately from light colors or whites. Mixing dark clothes with light clothes can result in dye transfer or discoloration of the lighter clothes.

Soil Level

Wash heavily soiled clothing together. Washing lightly soiled clothing in the same load with heavily soiled clothing could result in poor wash performance for the lightly soiled clothing.

Fabric Type

Delicate articles should not be mixed with heavy or sturdy fabric types. Washing heavy fabrics with delicates can result in poor wash performance for the heavy fabrics and possible damage to the delicates.

Lint Type

Some fabrics attract and bind lint to them while others give off lint in the laundry process. Avoid mixing these lint collectors and lint producers in the same load. Mixing these fabrics will result in pilling and linting on the lint collectors. (For example, lint collector - knit sweater; lint producer - terry cloth towels.)











How to Sort Laundry

By Colors	By Soil	By Fabric	By Lint
White	Heavy	Delicates	Lint Producer
Lights	Normal	Easy Care	Lint Collector

By Colors	By Soil	By Fabric	By Lint
Darks	Light	Sturdy	

Fabric Care Labels

Many articles of clothing include a fabric care label. Using the chart below, adjust the cycle and option selections to care for your clothing according to the manufacturer's recommendations.

Category	Label	Directions
 Washing		Hand wash
		Machine wash, Normal cycle
		Perm Press/Wrinkle Resistant setting (which has a cool down or cold spray before the slower spin)
		Gentle/Delicate setting (slow agitation and/or reduced wash time)
		Do not wash
		Do not wring
Water Temperature	...	Hot
	..	Warm
	.	Cold/Cool
 Bleach Symbols		Any bleach (when needed)
		Only non-chlorine bleach (when needed)
		Do not bleach

Loading the Washer

⚠ CAUTION

- Clothing or articles that are waterproof or water-resistant must be washed in the **Bedding** cycle only. (Examples include water resistant clothing, mattress covers, outdoor clothes, and plastic mats.) Failure to do so may result in personal injury or damage to the washer, clothes, walls, floor, and surrounding objects due to abnormal vibration.

- Brush off heavy soil, dust, and hair from items before washing. Excess dirt or sand can abrade other fabrics and lead to poor wash performance.
- For best performance, load clothes as shown.

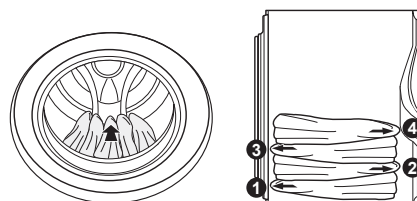

General Tips

- Check and empty pockets. Paper clips, coins, matches, etc. can damage clothing and the washer.
- Close zippers and hooks, and tie drawstrings to prevent snagging or tangling of clothes.
- Pretreat heavily stained areas for best results.
- Do not press down on items while stacking them in the drum.
- Load clothes loosely, and do not overfill the drum. Clothes need room to circulate in order to get clean.
- Combine large and small items in the drum. Load large items first. Large items should not be more than half of total load.

20 OPERATION

- The washer can be fully loaded, but the drum should not be tightly packed with items. The door of the washer must close easily.
- The washer will not fill or operate with the door open.

Bulky Items

- Wash thick, bulky items individually. Heavy blankets, comforters, bed spreads, or pet beds can get tangled or cause an unbalanced load if combined with other items.

Small Items

- Do not wash a single small item. Add enough similar items to the load to prevent an out-of-balance load.
- Wash small, light items in a mesh bag. Small items can get caught in the impeller at the bottom of the drum, and brassiere hooks can snag on other clothing or the drum.

Adding Cleaning Products

About Detergent Use

This washer is designed for use with only HE (High-Efficiency) detergents.



- HE detergents produce fewer suds, dissolve more efficiently to improve washing and rinsing performance, and help to keep the interior of the washer clean. Using detergent that is not HE may cause oversudsing and unsatisfactory performance which could result in error codes, cycle failure, and washer damage.
- Detergents designated as HE-compatible may not provide optimal results.
- For proper wash performance, always measure detergent using the measuring device provided by the detergent manufacturer. For an average load, use less than half of the recommended maximum. Use less detergent for soft water, light soil, or smaller loads.
- Use extra care when measuring 2X and 3X concentrated detergents because even a small amount of extra detergent can lead to problems.
- Never use more than the maximum amount of detergent recommended by the manufacturer. Using too much detergent can lead to

oversudsing, poor rinsing, detergent buildup in clothing, and residue buildup that can contribute to odors in the washer.

- Do not use more than one single-use detergent pack in the washer. Using too much detergent may cause oversudsing and unsatisfactory performance. Reduce detergent amount or add an extra rinse if detergent residue is left on fabrics. To add an extra rinse, select the **Extra Rinse** option.

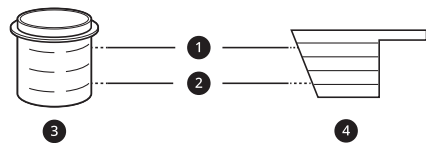

- 1 Maximum fill line
- 2 Average load fill line
- 3 Liquid detergent
- 4 Powdered detergent

Single-Use Detergent Packs

Place liquid or powdered detergent packs in the drum before loading laundry. Do not place detergent packs in the dispenser.

Using the Dispenser

To add cleaning products to the automatic dispenser:

- 1 Open the dispenser drawer.
- 2 Load the laundry products into the appropriate compartments.
 - Follow the manufacturer's recommendations when adding cleaning products.

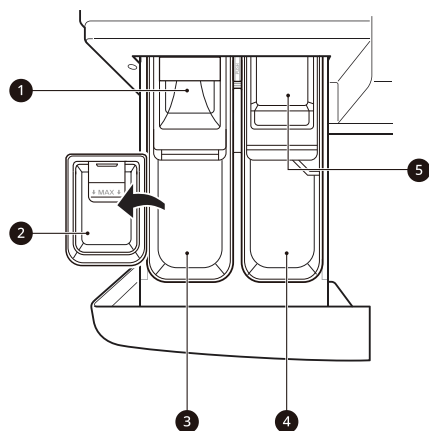

- ❶ Pre-wash detergent compartment (on some models)
- ❷ Liquid detergent cup
- ❸ Main wash detergent compartment
- ❹ Liquid fabric softener compartment
- ❺ Liquid chlorine bleach compartment

3 Gently close the detergent dispenser drawer before starting the cycle.

- Slamming the drawer closed may result in the detergent overflowing into another compartment or dispensing into the drum earlier than programmed.
- Be careful not to get a hand caught in the drawer while closing.
- It is normal for a small amount of water to remain in the dispenser compartments at the end of the cycle.

⚠ CAUTION

- Do not place or store laundry products, such as detergent, bleach, or liquid fabric softener, on top of your washer. These products can damage the washer's finish and controls.

Pre-wash Detergent Compartment

Add liquid or powdered detergent to this compartment when using the **Pre-wash** option. Always use HE (High-Efficiency) detergent with your washer.

- When using the **Pre-wash** option, liquid detergent for the main wash needs to be loaded in the liquid detergent cup accessory in the main wash dispenser (where applicable), to prevent it from being dispensed with the pre-wash detergent.

- The amount of detergent added for the **Pre-wash** option is 1/2 the amount recommended for the main wash cycle. For example, if the main wash cycle requires one measure of detergent, add 1/2 measure for the **Pre-wash** option.

Main Wash Detergent Compartment

This compartment holds laundry detergent for the main wash cycle. Either powdered or liquid detergent may be used in this compartment.

- The detergent is added to the load at the beginning of the cycle. Always use HE (High-Efficiency) detergent with your washer.
- Do not exceed the maximum fill line. Using too much detergent can result in detergent buildup in clothing and the washer.
- Liquid or powdered color-safe bleach may be added to the main wash compartment with detergent of the same type. Do not mix liquids and powders
- If the dispenser has a liquid detergent cup and insert:
 - Make sure they are in place when using liquid detergent.
 - Make sure to remove them when using powdered detergent. Powdered detergent will not dispense with the liquid detergent cup and insert in place.
- If you use a detergent that does not dissolve easily or a detergent with high viscosity, it will leave a residue and clog the dispenser.

Liquid Bleach Compartment

This compartment holds liquid bleach, which is dispensed automatically at the proper time during the wash cycle. The dispenser is activated twice to ensure complete dispensing of the bleach. Any liquid remaining in the dispenser at the end of the cycle is water, not bleach.

⚠ WARNING

- Do not mix chlorine bleach with ammonia or acids such as vinegar or rust/scale remover. Mixing chemicals like these can produce a lethal gas, resulting in severe injury or death.

NOTE

- Do not add powdered bleach to this compartment. The bleach compartment is designed to dispense liquid bleach only. Powdered or liquid color-safe bleach will not dispense properly.

NOTE

- Follow the manufacturer's recommendations when adding bleach. Never add more than one cup, and do not exceed the maximum fill line or the bleach may be dispensed immediately and damage fabrics. Using too much bleach can also damage fabrics.
 - Never pour undiluted liquid chlorine bleach directly onto the load or into the drum. Fabric damage can occur.
 - Do not use color-safe bleach or oxygen bleach in the same cycle with liquid chlorine bleach.
-

Fabric Softener Compartment

This compartment holds liquid fabric softener, which is automatically dispensed during the final rinse cycle. Either powdered or liquid fabric softener may be used.

- Do not exceed the maximum fill line. Using too much fabric softener may stain clothes or cause buildup on fabrics or in the washer.
- Dilute concentrated fabric softeners with warm water.
- Never pour fabric softener directly onto the load or into the drum.

Control Panel

Control Panel Features

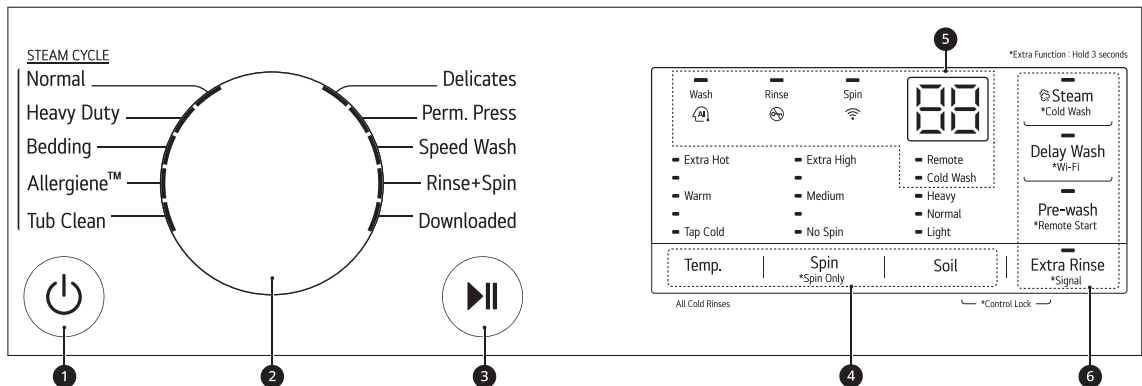

1 Power On/Off Button

- Press this button to turn the washer on or off.
- Pressing this button during a cycle will cancel that cycle and any load settings will be lost.
- The door will unlock after a brief pause.

NOTE

- If there is any water remaining in the drum after the washer shuts off, it will drain after a delay. The washer can be restarted at any time before the drain begins. However, once the water begins to drain, all functions will be suspended until the water has been completely drained and the washer shuts off.

2 Cycle Selector Knob

- Turn this knob to select the desired cycle.
- Once the desired cycle has been selected, the standard presets will appear in the display. These settings can be adjusted using the **Cycle Modifier buttons** at any time before starting the cycle.

3 Start/Pause Button

- Press this button to start the selected cycle.
- If the washer is running, use this button to pause the cycle without losing the current settings.

NOTE

- If the **Start/Pause** button is not pressed to start the selected cycle, after a delay the washer automatically turns off and all cycle settings are lost. Any water remaining in the drum will be drained.

4 Cycle Modifier Buttons

- Use these buttons to adjust the wash temperature, spin speed and soil level settings for the selected cycle.
- The current settings are shown in the display.
- Press the button for that option to select other settings.

5 Time and Status Display

6 Option and Extra Function Buttons

- These buttons allow you to select additional cycle options. Certain buttons also allow you to activate special functions by pressing and holding the button for **3 seconds**.

Time and Status Display

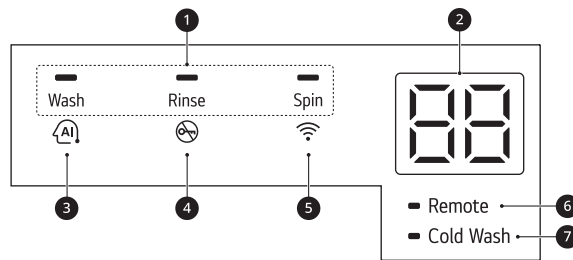

1 Cycle Status Indicators

- These LEDs will blink when a cycle is selected to indicate which stages will run.
- When a cycle is running, the LED for the active stage will blink, and the LEDs for the remaining stages will remain steady. Once a stage is complete, the LED will turn off. If a cycle is paused, the active stage LED will stop blinking.

2 Estimated Time Remaining

- When a cycle is selected, the default time for that cycle is displayed. This time will change as modifiers or options are selected.
- If the display shows ---, then the time will be displayed after the load sensing has detected the load size.
- The time shown is only an estimate. This time is based on normal operating conditions. Several external factors (load size, room temperature, incoming water temperature, etc.) can affect the actual time.

NOTE

- Once the **Start/Pause** button is pressed, the washer will measure the size of the load. The estimated time may change once the load size has been measured.
- If the **Delay Wash** function is set, the remaining delay time counts down until the cycle begins.

3 AI DD Indicator

- **AI DD** provides the appropriate drum rotation actions after load sensing is completed.
- This indicator lights up when:
 - the **Normal** cycle is selected and operated, except for when the **Heavy** soil level is selected.

4 Door Lock Indicator

- This indicator lights up when the cycle starts and the door is locked.
- The indicator light stays on until the cycle is paused, stopped or has finished.

5 Wi-Fi Indicator

- This indicator is lit when the product is connected to a home Wi-Fi network.

6 Remote Start Indicator

- This indicator lights up when the **Remote Start** feature is activated.

7 Cold Wash Indicator

- This indicator lights up when the **Cold Wash** feature is activated.

Wash Cycles

The wash cycles are designed for specific types of wash loads. Select the cycle that best matches the load contents for maximum wash performance and fabric care. See **Sorting Laundry** section for best results, and follow the fabric care labels on your garments. For a guide to fabric care symbols, see **Sorting Laundry** section.

Cycle Guide

Turn the knob or press the button to select the desired cycle. When you select a wash cycle, the light for the corresponding wash cycle will turn on.

NOTE

- Whenever load weights are mentioned, assume **1 lb (0.45 kg)** = 1 thick bath towel (dry).

• Extra Hot	• Extra High
• Hot	• High
• Warm	• Medium
• Cold	• Low
• Tap Cold	• No Spin
Temp.	Spin

- Temperature indicator lights up when one of **Tap Cold, Cold, Warm, Hot** or **Extra Hot** is selected.
- Spin indicator lights up when one of **No Spin, Low, Medium, High** or **Extra High** is selected.

Cycle	Normal	
Description	Use to wash all normal items such as cotton, linen, shirts, jeans or mixed loads, except delicate fabrics such as wool or silk. <ul style="list-style-type: none"> Pressing the Start/Pause button without selecting a cycle will cause the Normal cycle to begin immediately, using the default settings. 	
Wash Temp.	Default: Warm	Available: All
Spin Speed	Default: High	Available: All
Soil Level	Default: Normal	Available: All

Cycle	Heavy Duty	
Description	Suitable for washing heavily soiled laundry, such as cotton fabrics, using more powerful wash motions. <ul style="list-style-type: none"> When washing large loads, there will be brief periods of 2 minutes or more without agitation. These soak periods are part of the cycle's design, and are normal. 	
Wash Temp.	Default: Warm	Available: All
Spin Speed	Default: Extra High	Available: All
Soil Level	Default: Heavy	Available: All

Cycle	Bedding	
Description	Suitable for washing blankets or bulky items which have difficulty absorbing water, such as pillows, blankets, comforters, sheets or pet bedding. <ul style="list-style-type: none"> Do not use this cycle to wash a mixed load of bedding and non-bedding items. Do not mix large/bulky items with smaller articles of clothing. Do not wash excessively large items. If large/bulky items do not fit easily into the tub, there may not be enough room for them to move during washing. 	

Cycle	Bedding	
Wash Temp.	Default: Warm	Available: Hot, Warm, Cold, Tap Cold
Spin Speed	Default: Medium	Available: Medium, Low, No Spin
Soil Level	Default: Normal	Available: All

Cycle	Allergiene™	
Description	<p>This cycle is a powerful, high-temperature cycle designed specifically to reduce certain allergens.</p> <p>NOTE</p> <ul style="list-style-type: none"> • Selecting this cycle automatically incorporates steam into the wash cycle. • This cycle can significantly reduce allergens in bedding and clothing. • This cycle helps reduce dust mite populations and helps reduce allergens. Due to the higher energy and temperatures used, this cycle is not recommended for wool, silk, leather, or any other delicate or temperature sensitive items. 	
Spin Speed	Default: High	Available: All

Cycle	Tub Clean	
Description	This is a special cycle designed to clean the inside of the washer.	

Cycle	Delicates	
Description	Suitable for washing dress shirts/blouses, nylons, lingerie, or sheer and lacy clothes which can easily be damaged. (less than 8 lb (3.63 kg))	
Wash Temp.	Default: Cold	Available: Warm, Cold, Tap Cold
Spin Speed	Default: Medium	Available: Medium, Low, No Spin
Soil Level	Default: Normal	Available: All

Cycle	Perm. Press	
Description	Use this cycle to minimize wrinkles when washing tablecloths or “wrinkle-free” clothes.	
Wash Temp.	Default: Warm	Available: Hot, Warm, Cold, Tap Cold
Spin Speed	Default: Medium	Available: High, Medium, Low, No Spin
Soil Level	Default: Normal	Available: All

Cycle	Speed Wash	
Description	<p>Quickly washes lightly soiled clothing and small loads. For high wash and rinse efficiency, wash small loads of 2-3 lightly soiled garments. (less than 3 lb (1.36 kg))</p> <ul style="list-style-type: none"> • Use very little detergent in this cycle. To add an extra rinse, use the Extra Rinse option. 	
Wash Temp.	Default: Hot	Available: Hot, Warm, Cold, Tap Cold
Spin Speed	Default: Extra High	Available: All
Soil Level	Default: Light	Available: All

Cycle	Rinse+Spin
Description	<p>Select this cycle to rinse and spin a load separately from a regular cycle.</p> <ul style="list-style-type: none"> • This can be helpful in preventing fresh stains from setting in fabrics. • You can change the spin speed by pressing the Spin button repeatedly until the desired speed is selected.

Cycle	Downloaded (Small Load)	
Description	<p>You can use a smartphone to download a specialized cycle to this cycle position.</p> <ul style="list-style-type: none"> • The default cycle is Small Load, used for normally soiled loads with a few items. This cycle is also available for download. • Refer to the LG ThinQ application to see the cycles available for download. 	
Wash Temp.	Default: Warm	Available: Hot, Warm, Cold, Tap Cold
Spin Speed	Default: High	Available: All
Soil Level	Default: Normal	Available: All

Available Options

† This option is automatically included in the cycle and cannot be deselected.

NOTE

- **Delay Wash** and **Extra Rinse** can be selected for every cycle in this table.
- **Steam** and **Cold Wash** cannot be selected at the same time.

Cycle	Steam	Cold Wash	Pre-wash
Normal	●	●	●
Heavy Duty	●	●	●
Bedding	●	●	●
Allergiene™	●†		
Delicates		●	●
Perm. Press		●	●
Speed Wash		●	
Rinse+Spin			
Downloaded default: Small Load		●	●

Cycle Modifiers

About Modifier Buttons

Each cycle has default settings that are selected automatically. You may also customize these settings using the cycle modifier buttons.

- Repeatedly press the button for the desired modifier until the indicator light for the desired setting is lit.
- The washer automatically adjusts the water level for the type and size of wash load for best results and maximum efficiency.
- This is a high-efficiency washer, and the water levels may be much lower than you expect. This is normal, and cleaning/rinsing performance will not be compromised.

• Extra Hot	• Extra High	• Remote
• Warm	• Medium	• Cold Wash
• Tap Cold	• No Spin	• Heavy
		• Normal
		• Light
Temp.	Spin	Soil
	*Spin Only	

NOTE

- The LED next to the setting lights up when the setting is selected.
- To protect your garments, not every wash temperature, spin speed, soil level, or option is available with every cycle.
- A chime will sound twice and the LED will not light if the desired setting is not allowed for the selected cycle.
- Follow the fabric care labels on the garment for best results.

Temp.

Make sure the wash temperature is suitable for the type of load you are washing.

- Press the **Temp.** button repeatedly to select the wash and rinse temperature combination for the selected cycle.
- All rinses use unheated cold water.
- Cold rinses use less energy. The actual cold rinse temperature depends on the temperature of the cold water at the faucet.
- Your washer features a heating element to boost the hot water temperature for **Extra Hot** settings. This provides improved wash performance at normal water heater settings.

Spin

Higher spin speeds extract more water from clothes, reducing drying time and saving energy.

- Press the **Spin** button repeatedly until the desired speed is selected.
- Some fabrics, such as delicates, require a slower spin speed.

Spin Only

This option spins the load without a wash or rinse cycle. This is useful for spinning dry hand-washables.

- Press the **Spin** button for 3 seconds.

Soil

Adjusting the soil level setting will modify the cycle times and/or wash actions.

- Press the **Soil** button repeatedly until the desired soil level is selected.
- The **Heavy** soil setting may increase cycle times. The **Light** soil setting may decrease cycle times.

Options and Extra Functions

Your washer includes several additional cycle options to customize cycles to meet your individual needs.

- Select the desired option after selecting the desired cycle and settings.

NOTE

- The LED for the option will light when the option is selected.
- To protect your garments, not every option is available with every cycle.
- A chime will sound twice and the LED will not light if the selected option is not allowed for the selected cycle.

Steam

Adding this option to a wash cycle helps provide superior cleaning performance. Using steam gives fabrics the cleaning benefits of a very hot wash.

- Steam may not be clearly visible during the steam cycles. This is normal. Too much steam could damage clothing.
- Do not use steam with delicate fabrics such as wool and silk, or easily discolored fabrics.

⚠ WARNING

- Do not touch the door during steam cycles. The door surface can become very hot and can cause severe burns. Allow the door lock to release before opening the door.
- Do not attempt to override the door lock mechanism or reach into the washer during a steam cycle. Steam can cause severe burns.

Using the Pre-wash Option

This option adds a pre-wash (for about **15 - 17 minutes**) for improved cleaning of heavily soiled or stained clothing.

NOTE

- If you select **Pre-wash** after putting the detergent directly in the drum, the detergent may be washed away, reducing the washing performance.

Remote Start

Use a smartphone to control your washer remotely.

- For more information, see **SMART FUNCTIONS** in this manual.

Delay Wash

Once you have selected the cycle and other settings, press the **Delay Wash** button to delay the start of the wash cycle.

- Each press of this button increases the delay time by 1 hour, for up to 19 hours.
- Once the desired delay time is set, press the **Start/Pause** button to start the delay time.

NOTE

- If the **Start/Pause** button is not pressed to begin the delay time, the washer automatically turns off after a certain time and all cycle settings are lost.

Wi-Fi

When the washer is connected to a home Wi-Fi network, the  icon on the control panel is lit.

- To connect the washer to the **LG ThinQ** application, press and hold the **Delay Wash** button for 3 seconds.

Cold Wash

Press the **Cold Wash** button to save energy by using cooler water. It will increase the wash and rinse times to maintain wash performance.

- Wash time will increase up to several minutes with this option.
- For best wash results, only wash small loads (less than 8 lb) with this option.

Extra Rinse

This option adds an extra rinse to the selected cycle. Use this option to help ensure the removal of detergent or bleach residue from fabrics.

- Press the **Extra Rinse** button to add additional rinses to the cycle.

Control Lock

Use this function to disable the controls. This function can prevent children from changing cycles or operating this washer.

NOTE

- The function does not lock the door.
- Once this function is set, all buttons are locked except the **Power** button.
- When the controls are locked,  and the remaining time are alternately shown on the display during the wash cycle.
- Turning off the power will not reset this function. You must deactivate this function before you can access any other options and functions.

Locking/Unlocking the Control Panel

- 1 Turn on the power.
 - 2 Press and hold the **Soil** and **Extra Rinse** buttons for 3 seconds to activate/deactivate this function.
- When the function is deactivated, a chime will sound and the remaining time for the current cycle will reappear on the display.

Signal

The washer plays a melody when the wash cycle is finished. The buttons make a sound each time a button is pressed. Use this button to turn the melody and button tones on or off.

- To turn on/ff, press the **Signal** button.

SMART FUNCTIONS

Using LG ThinQ Application

The **LG ThinQ** application allows you to communicate with the appliance using a smartphone.

LG ThinQ Application Features

- **Remote Start**
 - It allows you to control the appliance remotely from the **LG ThinQ** application.
- **Downloaded**
 - It allows you to download new and specialized cycles that are not included in the standard cycles on the appliance.
- **Tub Clean Coach**
 - This function shows how many cycles remain before it is time to run the **Tub Clean** cycle.
- **Energy Monitoring**
 - This feature keeps track of the washer's power consumption affected by selected washing cycles and options.
- **Smart Diagnosis™**
 - This function provides useful information for diagnosing and solving issues with the appliance based on the pattern of use.
- **Push Alerts**
 - When the cycle is complete or the appliance has problems, you will receive a push message.
- **Settings**
 - Allows you to set various options on the appliance and in the application.

NOTE

- If you change your wireless router, Internet service provider, or password, delete the connected appliance from the **LG ThinQ** application and connect it again.
- This information is current at the time of publication. The application is subject to change for product improvement purposes without notice to users.

Before Using LG ThinQ Application

- 1 Check the distance between the appliance and the wireless router (Wi-Fi network).
 - If the distance between the appliance and the wireless router is too far, the signal strength becomes weak. It may take a long time to register or installation may fail.
- 2 Turn off the **Mobile data** or **Cellular Data** on your smartphone.

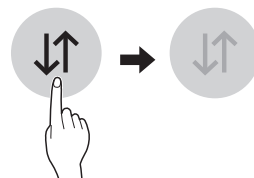

- 3 Connect your smartphone to the wireless router.

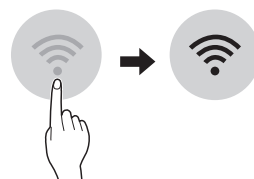

NOTE

- To verify the Wi-Fi connection, check that the  icon on the control panel is lit.
- The appliance supports 2.4 GHz Wi-Fi networks only. To check your network frequency, contact your Internet service provider or refer to your wireless router manual.
- **LG ThinQ** is not responsible for any network connection problems or any faults, malfunctions, or errors caused by network connection.
- If the appliance is having trouble connecting to the Wi-Fi network, it may be too far from the router. Purchase a Wi-Fi repeater (range extender) to improve the Wi-Fi signal strength.
- The Wi-Fi connection may not connect or may be interrupted because of the home network environment.
- The network connection may not work properly depending on the Internet service provider.
- The surrounding wireless environment can make the wireless network service run slowly.

NOTE

- If the appliance cannot be registered due to problems with the wireless signal transmission, unplug the appliance and wait about a minute before trying again.
- If the firewall on your wireless router is enabled, disable the firewall or add an exception to it.
- The wireless network name (SSID) should be a combination of English letters and numbers. (Do not use special characters.)
- Smartphone user interface (UI) may vary depending on the mobile operating system (OS) and the manufacturer.
- If the security protocol of the router is set to **WEP**, network setup may fail. Change the security protocol (**WPA2** is recommended) and register the product again.

Installing the LG ThinQ Application

Search for the **LG ThinQ** application from the Google Play Store or Apple App Store on a smartphone. Follow instructions to download and install the application.

Using the Appliance Remotely**Remote Start**

Use a smartphone to control your appliance remotely. You can also monitor your cycle operation so you know how much time is left in the cycle.

Using Remote Start

- 1 Put the laundry in the drum and add detergent to the detergent dispenser drawer.
 - If desired, add bleach or fabric softener to the appropriate areas of the dispenser.
- 2 Press the **Power** button.
- 3 Press and hold the **Remote Start** button for 3 seconds to enable the remote control function.
- 4 Start a cycle from the **LG ThinQ** application on your smartphone.

NOTE

- Once this function is enabled, you can only start a cycle from the **LG ThinQ** smartphone application. If the cycle is not started, the appliance will wait to start the cycle until it is turned off remotely from the application or this function is disabled.
- If the door has been opened, you cannot start a cycle remotely.

Disabling Remote Start Manually

When the function is activated, press and hold the **Remote Start** button for 3 seconds.

Download Cycle

You can download new and specialized cycles that are not included in the standard cycles on the appliance.

Appliances that have been successfully connected can download a variety of specialty cycles specific to the appliance.

Once cycle download is completed in the appliance, the product keeps the downloaded cycle until a new cycle is downloaded.

NOTE

- Only one downloaded cycle can be stored on the appliance at a time.

Wireless LAN Module Specifications

Model	LCW-004 or LCW-007
Frequency Range	2412 - 2462 MHz
Output Power (Max)	< 30 dBm

FCC Notice

The following notice covers the transmitter module contained in this product.

This equipment has been tested and found to comply with the limits for a Class B digital device, pursuant to Part 15 of the FCC Rules. These limits are designed to provide reasonable protection against harmful interference in a residential installation. This equipment generates, uses, and can radiate radio frequency energy and, if not installed and used in accordance with the instructions, may cause harmful interference to

radio communications. However, there is no guarantee that interference will not occur in a particular installation. If this equipment does cause harmful interference to radio or television reception, which can be determined by turning the equipment off and on, the user is encouraged to try to correct the interference by one or more of the following measures:

- Reorient or relocate the receiving antenna.
- Increase the separation between the equipment and the receiver.
- Connect the equipment to an outlet on a circuit different from that to which the receiver is connected.
- Consult the dealer or an experienced radio/TV technician for help.

This device complies with part 15 of the FCC Rules. Operation is subject to the following two conditions:

(1) This device may not cause harmful interference and

(2) This device must accept any interference received, including interference that may cause undesired operation.

Any changes or modifications in construction of this device which are not expressly approved by the party responsible for compliance could void the user's authority to operate the equipment.

FCC RF Radiation Exposure Statement

This equipment complies with FCC radiation exposure limits set forth for an uncontrolled environment. This transmitter must not be co-located or operating in conjunction with any other antenna or transmitter.

This equipment should be installed and operated with a minimum distance of 20 cm (7.8 inches) between the antenna and your body. Users must follow the specific operating instructions for satisfying RF exposure compliance.

Industry Canada Statement

This device contains licence-exempt transmitter(s)/ receiver(s) that comply with Innovation, Science and Economic Development Canada's licence-exempt RSS(s). Operation is subject to the following two conditions:

(1) This device may not cause interference.

(2) This device must accept any interference, including interference that may cause undesired operation of the device.

IC Radiation Exposure Statement

This equipment complies with IC radiation exposure limits set forth for an uncontrolled environment.

This equipment should be installed and operated with a minimum distance of 20 cm (7.8 inches) between the antenna and your body.

NOTE



- THE MANUFACTURER IS NOT RESPONSIBLE FOR ANY RADIO OR TV INTERFERENCE CAUSED BY UNAUTHORIZED MODIFICATIONS TO THIS EQUIPMENT. SUCH MODIFICATIONS COULD VOID THE USER'S AUTHORITY TO OPERATE THE EQUIPMENT.

Open Source Software Notice Information

To obtain the source code under GPL, LGPL, MPL, and other open source licenses, that is contained in this product, please visit <http://opensource.lge.com>. In addition to the source code, all referred license terms, warranty disclaimers and copyright notices are available for download.

LG Electronics will also provide open source code to you on CD-ROM for a charge covering the cost of performing such distribution (such as the cost of media, shipping, and handling) upon email request to opensource@lge.com. This offer is valid for a period of three years after our last shipment of this product. This offer is valid to anyone in receipt of this information.

Smart Diagnosis™ Function

This feature is only available on models with the  or  logo.

Use this feature to help you diagnose and solve problems with your appliance.

NOTE

- For reasons not attributable to LGE's negligence, the service may not operate due to external factors such as, but not limited to, Wi-Fi unavailability, Wi-Fi disconnection, local app store policy, or app unavailability.

- The feature may be subject to change without prior notice and may have a different form depending on where you are located.
-

Using LG ThinQ to Diagnose Issues

If you experience a problem with your Wi-Fi equipped appliance, it can transmit troubleshooting data to a smartphone using the **LG ThinQ** application.

- Launch the **LG ThinQ** application and select the **Smart Diagnosis™** feature in the menu. Follow the instructions provided in the **LG ThinQ** application.

Using Audible Diagnosis to Diagnose Issues

Follow the instructions below to use the audible diagnosis method.

- Launch the **LG ThinQ** application and select the **Smart Diagnosis™** feature in the menu. Follow the instructions for audible diagnosis provided in the **LG ThinQ** application.

1 Press the **Power** button to turn on the appliance.

- Do not press any other buttons.

2 Place the mouthpiece of your smartphone close to the  or  logo.

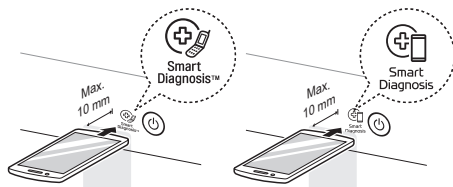

3 Press and hold the **Temp.** button for **3 seconds** or until the audible tones start. Hold the smartphone mouthpiece to the logo until the data transfer is complete.

- Keep the smartphone in place until the data transfer has finished. Time remaining for data transfer is displayed.

4 After the data transfer is complete, the diagnosis will be displayed in the application.

NOTE

- For best results, do not move the smartphone while the tones are being transmitted.
-

MAINTENANCE

WARNING

- To reduce the risk of fire, electric shock, or injury to persons, read this entire owner's manual, including the **SAFETY INSTRUCTIONS**, before operating this appliance.
- Unplug the appliance before cleaning to avoid the risk of electric shock. Failure to follow this warning can cause serious injury, fire, electric shock, or death.
- Do not use volatile substances (benzene, paint thinner, alcohol, acetone, etc.), abrasive cleaners, or detergents with strong chemical components when cleaning the appliance. Doing so may cause discoloration or damage to the appliance, or may cause a fire.
- Certain internal parts are intentionally not grounded and may present a risk of electric shock only during servicing. Service personnel - Do not contact the following parts while the appliance is energized: pump, valve, motor, control board.

Regular Cleaning

Care after Wash

After the cycle is finished, wipe the door and the inside of the door seal to remove any moisture.

- Wipe the body of the washer with a dry cloth to remove any moisture.
- Leave the door open to dry the drum interior.

WARNING

- Make sure children and pets do not climb into the drum. Engage the **Control Lock** feature if needed to prevent children from accidentally starting a wash cycle.

Cleaning the Exterior

Proper care of your washer can extend its life.

Door:

Wash with a damp cloth on the outside and inside and then dry with a soft cloth.

Exterior:

- Immediately wipe off any spills.

- Wipe with a damp cloth.
- Do not touch the surface or the display with sharp objects.

Periodic Maintenance

- Use a towel or soft cloth to wipe around the washer door opening and door glass.
- Always remove items from the washer as soon as the cycle is complete. Leaving damp items in the washer can cause wrinkling, color transfer, and odor.

Cleaning the Drum

Over time, residue may build up in the drum, leading to mildew or a musty odor. Run the **Tub Clean** cycle **monthly** to remove residue and prevent odor.

NOTE

- Make sure to run the **Tub Clean** cycle only when the drum is empty. Never load laundry while using this cycle. The laundry may be damaged or contaminated with cleaning products.
- Run the cycle more often under heavy use conditions or if odor is already present.
- If mildew or musty smell already exists, run this cycle once a week for three consecutive weeks.

- 1 Remove any clothing from the drum.
- 2 Add cleaning agents.

Cleaner	Instructions
Drum cleaner	Add to main detergent compartment of detergent dispenser
Lime scale remover	
Liquid chlorine bleach	Add to bleach compartment of detergent dispenser.
Powdered cleaner	Pull out liquid detergent cup before adding to main detergent compartment
Cleaning tablets	Place directly into the washer drum.

- For other drum cleaning products, follow the cleaner manufacturer's instructions and recommendations.

- Do not exceed the maximum fill line when adding bleach or powdered cleaners. Powdered cleaners may remain in the drum after cleaning.

- 3 Close the door and press the **Power** button.
- 4 Select the **Tub Clean** cycle then press the **Start/Pause** button to begin the cycle.
- 5 After the cycle ends, open the door and allow the drum interior to dry completely.

⚠ WARNING

- Make sure children and pets do not climb into the drum. Engage the **Control Lock** feature if needed to prevent children from accidentally starting a wash cycle.

NOTE

- If you use a descaler or drum cleaner during the **Tub Clean** cycle, use the **Rinse+Spin** option to rinse the washer drum before running your next wash cycle.

Automatic Alert for Tub Clean

When the power is on and the **EcL** message blinks on the display, it means the washer drum needs cleaning. Use the **Tub Clean** cycle to clean the washer drum. The frequency of the automatic alert's appearance depends on how often the washer is used. However, the message will generally appear every one to two months.

Removing Mineral Buildup

In areas with hard water, mineral scale can form on internal components of the washer. Periodically clean the mineral buildup on the internal components to extend the lifespan of the washer. Use of a water softener is recommended in areas with hard water.

- Use a descaler to remove visible mineral buildup on the washer drum.
- After descaling, always run the **Tub Clean** cycle before washing clothing.
- Mineral scale and other spots may be removed from the stainless steel drum using a soft cloth soaked in stainless steel cleaner.
- Do not use steel wool or abrasive cleaners.

Leaving the Door Open

After you finish using the washer, leave the door open overnight to allow air to circulate and dry the drum. This helps prevent odors.

Cleaning the Dispenser Drawer

Leaving detergent in the detergent dispenser drawer for an extended period of time or using the washer for a long period of time may cause the build-up of residue in the detergent dispenser drawer. Remove and clean the detergent dispenser drawer **once or twice a month**.

⚠ WARNING

- Do not spray water inside the washer. Doing so may cause fire or electric shock.

- 1 Turn off the washer, and unplug the power cord.
- 2 Pull the drawer straight out until it stops.
- 3 Press down hard on the disengage button **1** and pull the drawer completely out.

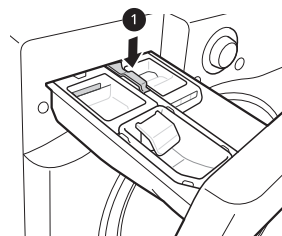

- 4 Remove the inserts from the drawer.
- 5 Clean the inserts and drawer with warm water.
 - Use a soft cloth or brush to clean and to remove any residue.
 - Do not use soap when cleaning the drawer and inserts.
- 6 Wipe off any moisture with a dry towel or cloth after cleaning.
- 7 To clean the drawer opening, use a small, non-metal brush to clean the recess. Remove all residue from the upper and lower parts of the recess.

8 Replace the drawer.

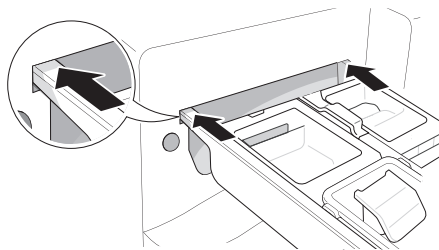

Cleaning the Door Seal

Clean the door seal **once a month** to prevent build-up of dirt.

CAUTION

- Cleaning the door seal with undiluted bleach may cause malfunction of the door seal and washer parts. You must add water to the bleach before using it.

- 1** Wear rubber gloves and protective goggles.
- 2** Dilute 3/4 cup (177 mL) of liquid chlorine bleach in 1 gallon (3.8 L) of water.
- 3** Wipe around the door seal.
 - Soak a sponge or a soft cloth in this diluted solution and wipe all around the door seal.
- 4** Wipe up any moisture with a dry towel or cloth after cleaning.
- 5** Leave the door open to allow the door seal to dry completely.

Cleaning the Water Inlet Filters

If the washer does not fill properly, an error message will appear on the display. The inlet valve filter screens could be clogged by hard water scale, sediment in the water supply, or other debris.

WARNING

- The inlet screens protect the delicate parts of the inlet valve from being damaged by particles that could enter the valves with the water supply. Operating the washer with these filters removed could cause a valve to open continuously, resulting in flooding and/or property damage.

CAUTION

- Do not use the washer without the inlet filters. Doing so will cause leaks and malfunction.
- If you use the washer in an area with hard water, the inlet filter may clog due to lime buildup and require more frequent cleaning.

- 1** Turn off the washer, and unplug the power cord.
- 2** Turn off hot and cold water faucets.
- 3** Unscrew the hot and cold water hoses from the back of the washer.
- 4** Remove the filters from the water valves carefully.
 - Use pliers to pull out the filters from the water valves.

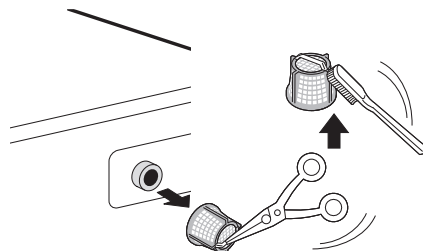

- 5** Remove foreign objects and soak the filters in white vinegar or a lime scale remover.
 - If using a lime scale remover, follow the manufacturer's instructions. Be careful not to damage the filters while cleaning them.
- 6** Rinse filters thoroughly and press them back into place.
- 7** Flush then reattach the water hoses.
 - Before reattaching the water inlet hoses, flush them by running several gallons of water through them into a bucket or drain, preferably with the faucets wide open for maximum flow.

NOTE

- An I E error message may blink on the display when the water pressure is low or an inlet filter is clogged with dirt. Clean the inlet filter.

Cleaning the Drain Pump Filter

The washer fails to drain if the drain pump filter is clogged. Periodically clean the drain filter to prevent clogging with foreign objects.

⚠ WARNING

- Opening the drain filter will result in water overflowing if there is water in the drum. Use a bucket if the drum is not completely drained before you open the drain filter.
- Using the washer without the drain filter or with an incorrectly assembled drain filter may cause leaks or malfunction of the washer.

1 Turn off the washer, and unplug the power cord.

2 Open the drain pump filter cover.

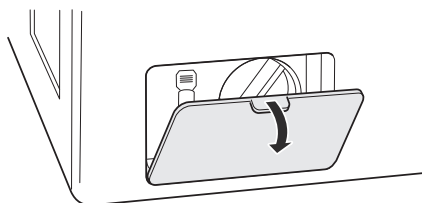

3 Drain any remaining water.

- Unclip the drain hose and remove the plug from the drain hose to drain the remaining water.

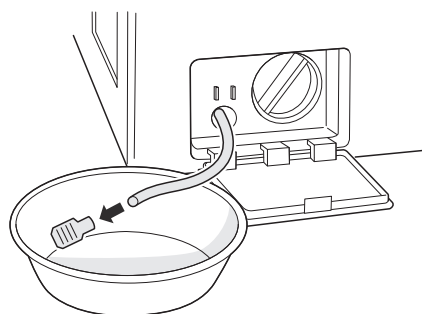

4 Remove the pump filter.

- Twist the pump filter counterclockwise to remove.

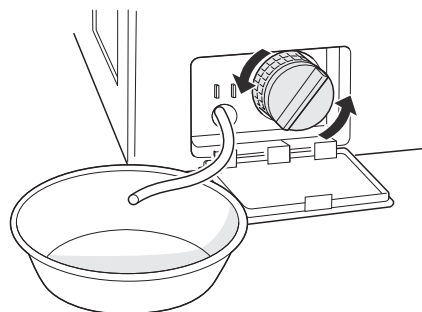

5 Clean the pump filter and opening.

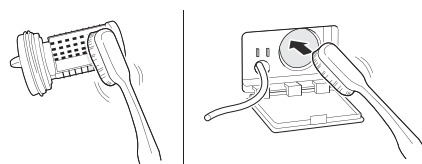

6 Reassemble the plug onto the drain hose and reclip the drain hose.

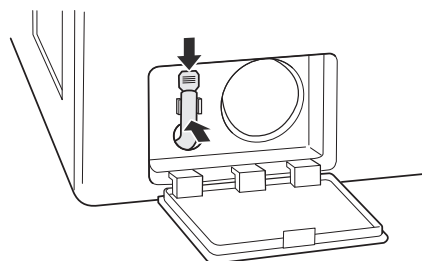

7 Insert the drain pump filter.

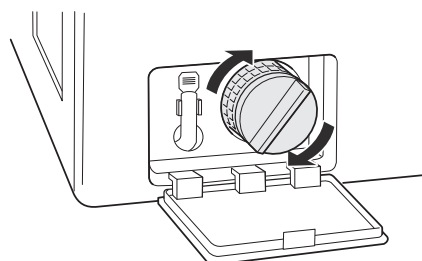

8 Close the drain pump filter cover.

NOTE

- An **UE** message blinks on the display when the drain pump filter is clogged with dirt. Clean the drain pump filter.

Care in Cold Climates

Storing the Washer

If the washer will not be used for an extended period of time and is in an area that could be exposed to freezing temperatures, follow these steps to protect the washer from damage.

NOTE

- Make sure the drum is empty before following these steps.

- 1 Turn off the washer, and unplug the power cord.
- 2 Turn off the water faucets.
- 3 Disconnect the hoses from the water supply. Drain any water from the hoses.

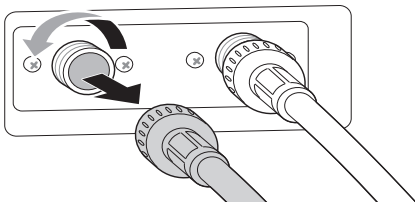

- 4 Plug the power cord into a properly grounded electrical outlet.
- 5 Add 1 gallon of nontoxic recreational vehicle (RV) antifreeze to the empty drum and close the door.
 - Never use automotive antifreeze.
- 6 Turn on the washer and press the **Spin** button.

- 7 Press the **Start/Pause** button to start the drain pump for **1 minute**.
 - This will expel some of the antifreeze, leaving enough to protect the washer from damage.
- 8 Turn off the washer and unplug the power cord.
- 9 Dry the drum interior with a soft cloth, and close the door.
- 10 Store the washer in an upright position.
- 11 Remove the inserts from the dispenser. Drain any water in the compartments and let them dry.
- 12 To remove the antifreeze from the washer after storage, run the **Rinse+Spin** cycle using detergent.
 - Do not add laundry to this cycle.

When the Water Inlet Hoses Are Frozen

- 1 Turn off the washer, and unplug the power cord.
- 2 Turn off the faucets connected to the water inlet hoses.
- 3 Pour hot water on the frozen faucets to thaw the water inlet hoses and remove the water inlet hoses.
- 4 Immerse the water inlet hoses in hot water to thaw them.
- 5 Reconnect the water inlet hoses to the water inlets of the washer and to the faucets.
 - See **Connecting the Water Inlet Hoses** for details.
- 6 Turn on the faucets.
- 7 Press the **Power** button to turn on the washer.

40 MAINTENANCE

- 8 Press the **Spin** button to operate spin only cycle for draining and spinning.
- 9 Press the **Start/Pause** button.

When the Drain Hose is Frozen

- 1 Pour hot water in the washer drum and close the door.
- 2 Wait for **1 - 2 hours**.
- 3 Press the **Power** button.
- 4 Press the **Spin** button to operate spin only cycle for draining and spinning.
- 5 Press the **Start/Pause** button to make sure the water drains.

TROUBLESHOOTING

Before Calling for Service

The washer is equipped with an automatic error-monitoring system to detect and diagnose problems at an early stage. If the washer does not function properly or does not function at all, check the following before you call for service.

FAQs

- Q: Why does my washer make loud banging noises while it is filling with water?**
- A:** This is actually a problem with the plumbing in your home. When the water valve in the washer shuts off, it can cause pipes in your home to move, resulting in a loud banging noise. This effect, called water hammer, can be reduced by installing an item called a water hammer arrestor. Add-on arrestors can be purchased through your local hardware or home improvement store.
- Q: Why is there so little water in my washer? How can it clean the clothes?**
- A:** HE (High-Efficiency) washers are designed to properly wash your laundry while using a minimum amount of water and energy. Because the water volume is low, the small amount of detergent used is more concentrated in the water, resulting in excellent cleaning performance.
- Q: When I press a button, why does my washer beep and then nothing happens?**
- A:** The **Control Lock** feature is turned on. To turn it off, turn on the washer, then press and hold the button that has **Control Lock** on or under it for **3 seconds**.
- Q: Where should I pour the powdered laundry products when doing my laundry?**
- A:** If you are using powdered laundry detergent, load it in the main detergent dispenser after removing the liquid detergent insert. Powdered laundry agents or powdered color safe bleach should be put directly into the drum. These products can be put in the empty drum before loading or on top of the laundry after loading the washer.

Error Messages

Problem	Possible Cause & Solution
I E INLET ERROR	Water supply faucets are not fully open. <ul style="list-style-type: none"> Make sure that the water faucets are fully open.
	Water inlet hoses are kinked, pinched, or crushed. <ul style="list-style-type: none"> Make sure that the hoses are not kinked, pinched or crushed behind or under the washer. Be careful when moving the washer during cleaning or maintenance.
	Water inlet filters are clogged. <ul style="list-style-type: none"> Clean the inlet filters. See MAINTENANCE.
	Water supply pressure to faucet or house is too low. <ul style="list-style-type: none"> Check another faucet in the house to make sure that household water pressure is adequate and flow is not restricted. Disconnect the water inlet hoses from the washer and run a few gallons of water through the hoses to flush out any dirt. If flow is too low, contact a plumber to have the water supply lines repaired.
	Water supply connected with leak-limiting hoses. <ul style="list-style-type: none"> The use of hoses designed to limit leaks is not recommended. Leak limiting hoses can trip falsely and prevent the washer from filling.

Problem	Possible Cause & Solution
UE UNBALANCE ERROR	<p>The load is too small.</p> <ul style="list-style-type: none"> • Add additional items to allow the washer to balance the load. <p>Heavy articles are mixed with lighter items.</p> <ul style="list-style-type: none"> • Always try to wash articles of somewhat similar weight to allow the washer to evenly distribute the weight of the load for spinning. <p>The load is out of balance.</p> <ul style="list-style-type: none"> • Manually redistribute the load if articles have become tangled, preventing the automatic rebalancing from working properly.
dE, dE 1, dE2, dE4 DOOR OPEN ERROR	<p>The door is not secured.</p> <ul style="list-style-type: none"> • Close and secure the door. If the message keeps appearing, unplug the power cord and call for service.
OE WATER OUTLET ERROR	<p>Drain hose is kinked, pinched, or clogged.</p> <ul style="list-style-type: none"> • Make sure that the drain hose is free of clogs or kinks and is not pinched behind or under the washer. <p>The end of the drain hose is more than 96 inches (2.4 m) above the bottom of the washer.</p> <ul style="list-style-type: none"> • Move the end of the drain hose so that it is lower than 96 inches (2.4 m).
EE TEMPERATURE SENSOR ERROR	<p>Control error.</p> <ul style="list-style-type: none"> • Unplug the washer and wait 60 minutes. Reconnect power and try again. • If the error code is still displayed, call for service
FE OVERFLOW ERROR	<p>Water level is too high due to a faulty water valve.</p> <ul style="list-style-type: none"> • Close the water faucets, unplug the washer, and call for service.
PE PRESSURE SENSOR ERROR	<p>The water level sensor is not working correctly.</p> <ul style="list-style-type: none"> • Close the water faucets, unplug the washer, and call for service.
LE MOTOR LOCKED ERROR	<p>A motor error has occurred.</p> <ul style="list-style-type: none"> • Allow the washer to stand for 30 minutes and then restart the cycle. • If the error code is still displayed, call for service.
Sud OVERSUDSING DETECTION	<p>Oversudsing of detergent</p> <ul style="list-style-type: none"> • Do not add more than the manufacturer's recommended amount of detergent. • To remove suds, turn the washer off then back on, then run the Rinse+Spin cycle. • If too many suds are detected during spinning, the washer stops to help prevent leaking.
PF WATER LEVEL SENSOR ERROR	<p>Water level is too low or high compared to the load.</p> <ul style="list-style-type: none"> • Unplug the washer and wait for 60 minutes. Reconnect power and try again. • If the error code is still displayed, call for service.
FF FROZEN ERROR	<p>Inlet hose, drain hose or drain pump is frozen.</p> <ul style="list-style-type: none"> • See Care in Cold Climates.
CL CONTROL LOCK FUNCTION	<p>The Control Lock function is on to prevent anyone from changing cycles or operating the washer.</p> <ul style="list-style-type: none"> • Turn off the Control Lock function in the control panel. See Control Lock under Options and Extra Functions.
EcL TUB CLEAN ALARM	<p>It is time to run the Tub Clean cycle.</p> <ul style="list-style-type: none"> • This is not an error code. It indicates that the Tub Clean cycle is running or needs to be run to clean the washer drum.

Problem	Possible Cause & Solution
U5 VIBRATION SENSOR ERROR	Vibration sensor malfunctions. <ul style="list-style-type: none"> • Call for service.

Noises

Problem	Possible Cause & Solution
Clicking	Door lock sounds when the door locks or unlocks. <ul style="list-style-type: none"> • Normal operation
Spraying or hissing	Water spraying or circulating during the cycle <ul style="list-style-type: none"> • Normal operation
Humming or Gurgling	Drain pump is pumping water from the washer at times during a cycle. <ul style="list-style-type: none"> • Normal operation
Water sloshing	A liquid in the balance ring around the pulsator helps the basket spin smoothly. <ul style="list-style-type: none"> • Normal operation
Water being added after the washer has already begun to operate	The washer adapts to the load size and type to add more water to the cycle as needed. <ul style="list-style-type: none"> • Normal operation
	The wash load may be unbalanced. If the washer senses that the load is unbalanced, it will stop and refill to redistribute the load. <ul style="list-style-type: none"> • Normal operation
	The washer may be diluting laundry additives to add to the wash load. <ul style="list-style-type: none"> • Normal operation
Rattling and clanking noise	Foreign objects, such as keys, coins, or safety pins may be in drum or pump. <ul style="list-style-type: none"> • Stop the washer, check the drum and the drain filter for foreign objects. • If noise continues after the washer is restarted, call for service.
Thumping sound	Heavy wash loads may produce a thumping sound. <ul style="list-style-type: none"> • This is normal, but if the sound continues, the washer is probably out of balance. Stop and redistribute wash load.
	Wash load may be out of balance. <ul style="list-style-type: none"> • Pause the cycle and redistribute the load after the door unlocks.
Vibrating noise	Packaging materials were not removed. <ul style="list-style-type: none"> • See Unpacking and Removing Shipping Material in INSTALLATION.
	Wash load may be unevenly distributed in the drum. <ul style="list-style-type: none"> • Pause the cycle and redistribute the load after the door unlocks.
	Not all leveling feet are resting firmly and evenly on the floor. <ul style="list-style-type: none"> • See Leveling the Washer in INSTALLATION.
	Floor is not rigid enough. <ul style="list-style-type: none"> • Make sure that the floor is solid and does not flex. See Flooring in INSTALLATION.
Squeaking noise	Packaging materials were not removed. <ul style="list-style-type: none"> • See Unpacking and Removing shipping Material in INSTALLATION.

Problem	Possible Cause & Solution
Banging noise when the washer is filling with water. (Water hammer)	Plumbing in the home moves or flexes when the water valves in the washer shut off. <ul style="list-style-type: none"> Water hammer is not caused by a defect in the washer. Install water hammer arrestors (purchased separately at hardware or home improvement store) between the fill hose and the washer for best results.
	Household water supply pressure is very high. <ul style="list-style-type: none"> Adjust household water supply regulator to a lower pressure or contact a plumber.

Operation

Problem	Possible Cause & Solution
Water Leaking	Hoses are not connected correctly. <ul style="list-style-type: none"> Check hoses and connectors for leaks, cracks, and splits. Check and tighten hose connections.
	House drain pipes are clogged. <ul style="list-style-type: none"> The washer pumps out water very rapidly. Check for water backing up out of the drain pipe during drain. If water is seen coming out of the drain, check for proper drain hose installation and check for restrictions in the drain. Contact a plumber to repair drain pipe.
	Drain hose has come out of the drain connector or is not inserted far enough. <ul style="list-style-type: none"> Tie drain hose to inlet hose or standpipe to prevent it from coming out during drain. For smaller drain pipes, insert the drain hose into the pipe as far as the drain hose flange. For larger drain pipes, insert the drain hose into the pipe 1 - 2 inches past the flange.
	Oversudsing of detergent <ul style="list-style-type: none"> Oversudsing may create leaks, and may be caused by the type and amount of detergent used. HE (High-Efficiency) detergent is the only detergent recommended. The normal amount of detergent to use is 1/4 to 1/2 of the maximum amount recommended by the detergent manufacturer. Always reduce the amount of detergent if the load is small or lightly soiled, or if the water is very soft. Never use more than the maximum amount recommended by the detergent manufacturer.
Excessive sudsing	Too much detergent or incorrect detergent <ul style="list-style-type: none"> HE detergents are formulated specifically for HE (High-Efficiency) washers and contain suds reducing agents. Only use detergent with the HE (High-Efficiency) logo. For detergent quantities refer to Detergent Use in OPERATION. If sudsing or detergent residue continues to be an issue, add an extra rinse.
Washer will not turn on.	Power cord is not properly plugged in. <ul style="list-style-type: none"> Make sure that the plug is plugged securely into a grounded, 3-prong, 120-VAC, 60 Hz outlet.
	House fuse is blown, circuit breaker has tripped, or power outage has occurred. <ul style="list-style-type: none"> Reset circuit breaker or replace fuse. Do not increase fuse capacity. If the problem is a circuit overload, have it corrected by a qualified electrician.
Wash cycle time is longer than usual.	The washer automatically adjusts the wash time for the amount of laundry, water pressure and other operating conditions. <ul style="list-style-type: none"> This is normal. The washer adjusts cycle time automatically to provide optimal results for the selected cycle. The time remaining shown in the display is only an estimate. Actual time may vary.

Problem	Possible Cause & Solution
Incomplete or no dispensing of detergent	Detergent compartments clogged from incorrect filling. <ul style="list-style-type: none"> • Make sure that detergent and additives are put into the correct dispenser compartments. • For all detergent types, always make sure that the dispenser drawer is fully closed before the start of the cycle.
	Too much detergent used. <ul style="list-style-type: none"> • Make sure that the suggested amount of detergent is used according to the manufacturer's recommendations. You may also dilute the detergent with water to the maximum fill line on the compartment to avoid clogging. Use only HE (High-Efficiency) detergent.
	NOTE <ul style="list-style-type: none"> • Always use as little detergent as possible. HE (High-Efficiency) washers need very little detergent to achieve optimum results. Using too much detergent will cause poor wash and rinse performance and may contribute to odors in the washer.
	Insufficient water supply <ul style="list-style-type: none"> • Make sure that both hot and cold water faucets are turned on all the way.
	Normal residue <ul style="list-style-type: none"> • It is normal for a small amount of detergent to remain in the dispenser. If this residue builds up, it can interfere with normal dispensing of detergents. Refer to the cleaning instructions.
Washer will not operate.	Control panel has powered off due to inactivity. <ul style="list-style-type: none"> • This is normal. Press the Power button to turn on the washer.
	Washer is unplugged. <ul style="list-style-type: none"> • Make sure that the power cord is plugged securely into an electrical outlet.
	Water supply is turned off. <ul style="list-style-type: none"> • Turn both hot and cold faucets fully on.
	Controls are not set properly. <ul style="list-style-type: none"> • Make sure that the cycle was set correctly, close the door and press the Start/Pause button to start the wash cycle.
	Door is open. <ul style="list-style-type: none"> • Close the door and make sure that nothing is caught under the door preventing it from closing completely.
	Circuit breaker/fuse is tripped/blown. <ul style="list-style-type: none"> • Check house circuit breakers/fuses. Replace fuses or reset breaker. The washer should be on a dedicated branch circuit.
	Start/Pause button was not pressed after the cycle was set. <ul style="list-style-type: none"> • Press the Power button then reselect the desired cycle and press the Start/Pause button. If the Start/Pause button is not pressed within a certain time, the washer will be turned off. (The time varies by model, from 4 to 60 minutes.)
	Extremely low water pressure. <ul style="list-style-type: none"> • Check another faucet in the house to make sure that household water pressure is adequate.
	Washer is too cold. <ul style="list-style-type: none"> • If the washer has been exposed to temperatures below freezing for an extended period of time, allow it to warm up before pressing the Power button. Otherwise, the display will not come on.

Problem	Possible Cause & Solution
Washer is not filling properly.	Filter is clogged. <ul style="list-style-type: none"> Make sure that inlet filters on the fill valves are not clogged. Refer to Cleaning the Water Inlet Filters in MAINTENANCE.
	Inlet hoses may be kinked. <ul style="list-style-type: none"> Check that inlet hoses are not kinked or clogged.
	Energy efficiency <ul style="list-style-type: none"> This is a High-Efficiency (HE) washer. As a result, the water level settings for this washer may be different than for conventional washer.
	Insufficient water supply <ul style="list-style-type: none"> Make sure that both hot and cold water faucets are turned on all the way.
	Washer door is open. <ul style="list-style-type: none"> Close the door and make sure that nothing is caught under the door preventing it from closing completely.
	Water level is too low. <ul style="list-style-type: none"> The water will not normally cover the clothes. The fill level is optimized for the wash motion to achieve the best wash performance.
Water in the washer does not drain or drains slowly.	Drain hose is kinked, pinched, or clogged. <ul style="list-style-type: none"> Make sure that the drain hose is free of clogs or kinks and is not pinched behind or under the washer.
	The end of the drain hose is more than 96 inches (2.4 m) above the bottom of the washer. <ul style="list-style-type: none"> Move the end of the drain hose so that it is lower than 96 inches (2.4 m).
Bleach does not dispense.	Bleach dispenser cover is not properly installed (on some models). <ul style="list-style-type: none"> Make sure that the bleach cover is properly installed and snapped into place before the beginning of the cycle.
	Bleach dispenser is dirty or clogged. <ul style="list-style-type: none"> Lift out the bleach dispenser cover and clean out the reservoir. Lint and other foreign debris that are collected inside the dispenser may prevent proper dispensing of the bleach.
Premature dispensing of bleach	Bleach dispenser filled for future load. <ul style="list-style-type: none"> You cannot store bleach in the dispenser for future use. The bleach will be dispensed every load.
	Overfilling the bleach dispenser <ul style="list-style-type: none"> Overfilling the bleach dispenser will cause the bleach to dispense immediately, which will damage the laundry or the washer. Always measure bleach, but never fill above the max line on the dispenser. A half cup of bleach is sufficient for most loads. Never use more than 1 cup of bleach.

Performance

Problem	Possible Cause & Solution
Wrinkling	Washer is not unloaded promptly. <ul style="list-style-type: none"> Always remove items from the washer as soon as the cycle is complete.
	Washer is overloaded. <ul style="list-style-type: none"> The washer can be fully loaded, but the drum should not be tightly packed with items. The door of the washer should close easily.
	Hot and cold water inlet hoses are reversed. <ul style="list-style-type: none"> Hot water rinse can set wrinkles in garments. Check the Inlet hose connectors.
Staining	Bleach or softener dispensed too soon. <ul style="list-style-type: none"> Dispenser compartment was overfilled or closed too quickly, causing the bleach or softener to dispense immediately. Always measure bleach, and never use more than 1 cup.
	Bleach or softener was added directly to the wash load in the drum. <ul style="list-style-type: none"> Always use the dispensers to ensure that laundry products are properly dispensed at the right time in the cycle.
	Washer was not unloaded promptly. <ul style="list-style-type: none"> Always remove items from the washer as soon as possible after the cycle is completed.
	Washer was not unloaded promptly. <ul style="list-style-type: none"> Always remove items from the washer as soon as possible after the cycle is completed.
	Clothes were not properly sorted. <ul style="list-style-type: none"> Always wash dark colors separately from light colors and whites to prevent discoloration. Never wash heavily soiled items with lightly soiled items.
Poor stain removal	Proper options are not selected. <ul style="list-style-type: none"> Heavier soils and tougher stains may require extra cleaning power. Select the Heavy feature to boost the cleaning power of the selected cycle.
	Previously set stains. <ul style="list-style-type: none"> Articles that have previously been washed may have stains that have been set. These stains may be difficult to remove and may require hand washing or pre-treating to aid in stain removal.
Musty or mildewy odor in the washer	Incorrect or too much detergent has been used. <ul style="list-style-type: none"> Use only HE (High-Efficiency) detergent in accordance with the manufacturer's instructions.
	Inside of the drum was not cleaned properly. <ul style="list-style-type: none"> Run the Tub Clean cycle regularly.

Odor

Problem	Possible Cause & Solution
Odor	<p>Some odor is caused by the rubber attached to the washing machine.</p> <ul style="list-style-type: none"> • This odor is normal for new rubber and will disappear after the machine has been run a few times.
	<p>If the rubber door gasket and door seal area are not cleaned regularly, odors can occur from mold or foreign substances.</p> <ul style="list-style-type: none"> • Be sure to clean the gasket and door seal regularly and check under the door seal for small items when unloading the washer.
	<p>Odors can occur if foreign substances are left in the drainage pump filter.</p> <ul style="list-style-type: none"> • Be sure to clean the drainage pump filter regularly.
	<p>Odors can occur if the drainage hose is not properly installed, causing siphoning (water flowing back inside the washing machine).</p> <ul style="list-style-type: none"> • When installing the drainage hose, be sure that it doesn't become kinked or blocked.
	<p>Using the dry function, odors can occur from lint and other laundry matter sticking to the heater. (Dryer model only)</p> <ul style="list-style-type: none"> • This is not a malfunction.
	<p>A particular odor can occur from drying wet clothes with hot air. (Dryer model only)</p> <ul style="list-style-type: none"> • The odor will disappear after a short while.

Wi-Fi

Problem	Possible Cause & Solution
Trouble connecting appliance and smartphone to Wi-Fi network	<p>The password for the Wi-Fi network was entered incorrectly.</p> <ul style="list-style-type: none"> • Delete your home Wi-Fi network and begin the connection process again.
	<p>Mobile data for your smartphone is turned on.</p> <ul style="list-style-type: none"> • Turn off the Mobile data on your smartphone before connecting the appliance.
	<p>The wireless network name (SSID) is set incorrectly.</p> <ul style="list-style-type: none"> • The wireless network name (SSID) should be a combination of English letters and numbers. (Do not use special characters.)
	<p>The router frequency is not 2.4 GHz.</p> <ul style="list-style-type: none"> • Only a 2.4 GHz router frequency is supported. Set the wireless router to 2.4 GHz and connect the appliance to the wireless router. To check the router frequency, check with your Internet service provider or the router manufacturer.
	<p>The appliance and the router are too far apart.</p> <ul style="list-style-type: none"> • If the appliance is too far from the router, the signal may be weak and the connection may not be configured correctly. Move the router closer to the appliance or purchase and install a Wi-Fi repeater.

LIMITED WARRANTY

USA

TERMS AND CONDITIONS

ARBITRATION NOTICE: THIS LIMITED WARRANTY CONTAINS AN ARBITRATION PROVISION THAT REQUIRES YOU AND LG ELECTRONICS (“LG”) TO RESOLVE DISPUTES BY BINDING ARBITRATION INSTEAD OF IN COURT, UNLESS YOU CHOOSE TO OPT OUT. IN ARBITRATION, CLASS ACTIONS AND JURY TRIALS ARE NOT PERMITTED. PLEASE SEE THE SECTION TITLED “PROCEDURE FOR RESOLVING DISPUTES” BELOW.

Should your LG Washer (“Product”) fail due to a defect in materials or workmanship under normal and proper use, during the warranty period set forth below, LG will, at its option, repair or replace the Product. This limited warranty is valid only to the original retail purchaser of the Product (“You”) and applies only when purchased lawfully and used within the United States including U.S. Territories.

WARRANTY PERIOD		
Washer	Direct Drive Motor (Stator or Rotor)	Stainless Steel Drum
One (1) year from the date of original retail purchase	Ten (10) years from the date of original retail purchase	Three (3) years from the date of original retail purchase
Parts and Labor (internal/functional parts only)	Parts only (You are responsible for any applicable labor cost)	Parts only (You are responsible for any applicable labor cost)

- Replacement Products and parts are warranted for the remaining portion of the original warranty period or ninety (90) days, whichever is greater.
- Replacement Products and parts may be new, reconditioned, refurbished, or otherwise factory remanufactured.
- Replaced Product or part(s) will be the property of LG.
- Proof of original retail purchase specifying the Product model and date of purchase is required to obtain warranty service under this limited warranty.
- Warranty start date will be ninety (90) days from manufacture date absent valid proof of purchase.

EXCEPT TO THE EXTENT PROHIBITED BY APPLICABLE LAW, ANY IMPLIED WARRANTY OF MERCHANTABILITY OR FITNESS FOR A PARTICULAR PURPOSE ON THE PRODUCT IS LIMITED IN DURATION TO THE DURATION OF THE ABOVE LIMITED WARRANTY. UNDER NO CIRCUMSTANCES SHALL LG OR ITS U.S. DISTRIBUTORS/DEALERS BE LIABLE FOR ANY INDIRECT, INCIDENTAL, CONSEQUENTIAL, SPECIAL, OR PUNITIVE DAMAGES, INCLUDING, WITHOUT LIMITATION, LOST GOODWILL, LOST REVENUES OR PROFITS, WORK STOPPAGE, IMPAIRMENT OF OTHER GOODS, COST OF REMOVAL AND REINSTALLATION OF THE PRODUCT, LOSS OF USE, OR ANY OTHER DAMAGES WHETHER BASED IN CONTRACT, TORT, OR OTHERWISE. LG’S TOTAL LIABILITY, IF ANY, SHALL NOT EXCEED THE PURCHASE PRICE PAID BY YOU FOR THE PRODUCT.

SOME STATES DO NOT ALLOW THE EXCLUSION OR LIMITATION OF INCIDENTAL OR CONSEQUENTIAL DAMAGES OR LIMITATIONS ON HOW LONG AN IMPLIED WARRANTY LASTS, SO THE ABOVE EXCLUSIONS OR LIMITATIONS MAY NOT APPLY TO YOU. THIS LIMITED WARRANTY GIVES YOU SPECIFIC LEGAL RIGHTS AND YOU MAY ALSO HAVE OTHER RIGHTS THAT VARY FROM STATE TO STATE.

THIS LIMITED WARRANTY DOES NOT COVER:

- Service trips to deliver, pick up, or install, educate how to operate, correct wiring, or correct unauthorized repairs.
- Damage or failure of the Product to perform during power failures and interrupted or inadequate electrical service.

- Damage or failure of the Product caused by leaky or broken water pipes, frozen water pipes, restricted drain lines, inadequate or interrupted water supply or inadequate supply of air.
- Damage or failure of the Product resulting from operating the Product in a corrosive atmosphere or contrary to the Product owner's manual.
- Damage or failure of the Product caused by accidents, pests and vermin, lightning, wind, fire, floods, acts of nature, or any other causes beyond the control of LG.
- Damage or failure of the Product caused by unauthorized modification or alteration, or if it is used for other than the intended purpose, or any water leakage where the Product was not properly installed.
- Damage or failure of the Product caused by incorrect electrical current, voltage, or plumbing codes.
- Damage or failure of the Product caused by use of parts, accessories, components, consumable cleaning products, any other products, or service that are not authorized by LG.
- Replacement of light bulbs, filters, fuses, or any other consumable parts.
- Damage or failure of the Product caused by transportation, storage, and/or handling, including scratches, dents, chips, and/or other damage to the finish of your Product, unless such damage is reported within one (1) week of delivery.
- Damage or missing items to any display, open box, or discounted Product.
- Refurbished Product or any Product sold "As Is", "Where Is", "With all Faults", or similar disclaimer.
- Products with original serial numbers that have been removed, altered, or cannot be readily determined.
- Increases in utility costs and additional utility expenses.
- Any noises associated with normal operation.
- Products used for other than normal and proper household use (e.g. commercial or industrial use, offices, and recreational facilities or vehicles) or contrary to the Product owner's manual.
- Costs associated with removal and reinstallation of your Product for repairs.
- The removal and reinstallation of the Product if it is installed in an inaccessible location or is not installed in accordance with the Product owner's manual.
- Damage or failure of the Product resulting from misuse, abuse, improper installation/repair/maintenance or service not approved by LG.

The cost of repair or replacement under the above excluded circumstances shall be borne by You.

TO OBTAIN WARRANTY SERVICE AND ADDITIONAL INFORMATION

Call 1-800-243-0000 and select the appropriate option from the menu.

Or visit our website at <http://www.lg.com>

Or by mail: LG Electronics Customer Service P.O. Box 240007 Huntsville, AL 35813 ATTN: Customer Service

PROCEDURE FOR RESOLVING DISPUTES:

ALL DISPUTES BETWEEN YOU AND LG ARISING OUT OF OR RELATING IN ANY WAY TO THIS LIMITED WARRANTY OR THE PRODUCT SHALL BE RESOLVED EXCLUSIVELY THROUGH BINDING ARBITRATION, AND NOT IN A COURT OF GENERAL JURISDICTION. BINDING ARBITRATION MEANS THAT YOU AND LG ARE EACH WAIVING THE RIGHT TO A JURY TRIAL AND TO BRING OR PARTICIPATE IN A CLASS ACTION.

Definitions. For the purposes of this section, references to "LG" mean LG Electronics U.S.A., Inc., its parents, subsidiaries and affiliates, and each of their officers, directors, employees, agents, beneficiaries, predecessors in interest, successors, assigns and suppliers; references to "dispute" or "claim" shall include any dispute, claim or controversy of any kind whatsoever (whether based in contract, tort, statute, regulation, ordinance, fraud, misrepresentation or any other legal or equitable theory) arising out of or relating in any way to the sale, condition or performance of the product or this Limited Warranty.

Notice of Dispute. In the event you intend to commence an arbitration proceeding, you must first notify LG in writing at least 30 days in advance of initiating the arbitration by sending a letter to LG at LG Electronics, USA, Inc. Attn: Legal Department-Arbitration 111 Sylvan Avenue, Englewood Cliffs, NJ 07632. You and LG agree to engage in good faith discussions in an attempt to amicably resolve your claim. The notice must provide your name, address, and telephone number; identify the product that is the subject of

the claim; and describe the nature of the claim and the relief being sought. If you and LG are unable to resolve the dispute within 30 days, either party may proceed to file a claim for arbitration.

Agreement to Binding Arbitration and Class Action Waiver. Upon failure to resolve the dispute during the 30 day period after sending written notice to LG, you and LG agree to resolve any claims between us only by binding arbitration on an individual basis, unless you opt out as provided below. Any dispute between you and LG shall not be combined or consolidated with a dispute involving any other person's or entity's product or claim. More specifically, without limitation of the foregoing, any dispute between you and LG shall not under any circumstances proceed as part of a class or representative action. Instead of arbitration, either party may bring an individual action in small claims court, but that small claims court action may not be brought on a class or representative basis.

Arbitration Rules and Procedures. To begin arbitration of a claim, either you or LG must make a written demand for arbitration. The arbitration will be administered by the American Arbitration Association ("AAA") and will be conducted before a single arbitrator under the AAA's Consumer Arbitration Rules that are in effect at the time the arbitration is initiated (referred to as the "AAA Rules") and under the procedures set forth in this section. The AAA Rules are available online at www.adr.org/consumer. Send a copy of your written demand for arbitration, as well as a copy of this provision, to the AAA in the manner described in the AAA Rules. You must also send a copy of your written demand to LG at LG Electronics, USA, Inc. Attn: Legal Department-Arbitration 111 Sylvan Avenue, Englewood Cliffs, NJ 07632. If there is a conflict between the AAA Rules and the rules set forth in this section, the rules set forth in this section will govern. This arbitration provision is governed by the Federal Arbitration Act. Judgment may be entered on the arbitrator's award in any court of competent jurisdiction. All issues are for the arbitrator to decide, except that issues relating to the scope and enforceability of the arbitration provision and to the arbitrability of the dispute are for the court to decide. The arbitrator is bound by the terms of this provision.

Governing Law. The law of the state of your residence shall govern this Limited Warranty and any disputes between us except to the extent that such law is preempted by or inconsistent with applicable federal law.

Fees/Costs. You do not need to pay any fee to begin an arbitration. Upon receipt of your written demand for arbitration, LG will promptly pay all arbitration filing fees to the AAA unless you seek more than \$25,000 in damages, in which case the payment of these fees will be governed by the AAA Rules. Except as otherwise provided for herein, LG will pay all AAA filing, administration and arbitrator fees for any arbitration initiated in accordance with the AAA Rules and this arbitration provision. If you prevail in the arbitration, LG will pay your attorneys' fees and expenses as long as they are reasonable, by considering factors including, but not limited to, the purchase amount and claim amount. Notwithstanding the foregoing, if applicable law allows for an award of reasonable attorneys' fees and expenses, an arbitrator can award them to the same extent that a court would. If the arbitrator finds either the substance of your claim or the relief sought in the demand is frivolous or brought for an improper purpose (as measured by the standards set forth in Federal Rule of Civil Procedure 11(b)), then the payment of all arbitration fees will be governed by the AAA Rules. In such a situation, you agree to reimburse LG for all monies previously disbursed by it that are otherwise your obligation to pay under the AAA Rules. Except as otherwise provided for, LG waives any rights it may have to seek attorneys' fees and expenses from you if LG prevails in the arbitration.

Hearings and Location. If your claim is for \$25,000 or less, you may choose to have the arbitration conducted solely on the basis of (1) documents submitted to the arbitrator, (2) through a telephonic hearing, or (3) by an in-person hearing as established by the AAA Rules. If your claim exceeds \$25,000, the right to a hearing will be determined by the AAA Rules. Any in-person arbitration hearings will be held at a location within the federal judicial district in which you reside unless we both agree to another location or we agree to a telephonic arbitration.

Opt Out. You may opt out of this dispute resolution procedure. If you opt out, neither you nor LG can require the other to participate in an arbitration proceeding. To opt out, you must send notice to LG no later than 30 calendar days from the date of the first consumer purchaser's purchase of the product by either: (i) sending an e-mail to optout@lge.com, with the subject line: "Arbitration Opt Out" or (ii) calling 1-800-980-2973. You must include in the opt out e-mail or provide by telephone: (a) your name and address; (b) the date on which the product was purchased; (c) the product model name or model number; and (d) the serial number (the serial number can be found (i) on the product; or (ii) online by accessing <https://www.lg.com/us/support/repair-service/schedule-repair> continued and clicking on "Find My Model & Serial Number").

You may only opt out of the dispute resolution procedure in the manner described above (that is, by e-mail or telephone); no other form of notice will be effective to opt out of this dispute resolution procedure. Opting out of this dispute resolution procedure will not affect the coverage of the Limited Warranty in any way, and you will continue to enjoy the full benefits of the Limited Warranty. If you keep this product and do not opt out, then you accept all terms and conditions of the arbitration provision described above.

CANADA

TERMS AND CONDITIONS

ARBITRATION NOTICE: THIS LIMITED WARRANTY CONTAINS AN ARBITRATION PROVISION THAT REQUIRES YOU AND LG TO RESOLVE DISPUTES BY BINDING ARBITRATION INSTEAD OF IN COURT, UNLESS THE LAWS OF YOUR PROVINCE OR TERRITORY DO NOT PERMIT THAT, OR, IN OTHER JURISDICTIONS, IF YOU CHOOSE TO OPT OUT. IN ARBITRATION, CLASS ACTIONS AND JURY TRIALS ARE NOT PERMITTED. PLEASE SEE THE SECTION TITLED "PROCEDURE FOR RESOLVING DISPUTES" BELOW.

Should your LG Washer ("Product") fail due to a defect in materials or workmanship under normal and proper use, during the warranty period set forth below, LG Electronics Canada, Inc. ("LGECI") will, at its option, repair or replace the Product upon receipt of proof of the original retail purchase. This limited warranty is valid only to the original retail purchaser of the Product and applies only to a Product distributed, purchased and used within Canada, as determined at the sole discretion of LGECI.

WARRANTY PERIOD (Note: If the original date of purchase cannot be verified, the warranty will begin sixty (60) days from the date of manufacture)		
Washer	Stainless Steel Drum	Direct Drive Motor (Motor or Rotor)
One (1) year from the date of original retail purchase	Three (3) years from the date of original retail purchase	Ten (10) years from the date of original retail purchase
Parts and Labor (internal/functional parts only)	Parts only (Consumer will be charged for labor)	Part only (Consumer will be charged for labor)

- Replacement products and parts are warranted for the remaining portion of the original warranty period or ninety (90) days, whichever is greater.
- Replacement products and parts may be new, reconditioned, refurbished, or otherwise factory remanufactured, all at the sole discretion of LGECI.
- Proof of original retail purchase specifying the Product model and date of purchase is required to obtain warranty service under this Limited Warranty.

LGECI'S SOLE LIABILITY IS LIMITED TO THE LIMITED WARRANTY SET OUT ABOVE. EXCEPT AS EXPRESSLY PROVIDED ABOVE, LGECI MAKES NO, AND HEREBY DISCLAIMS, ALL OTHER WARRANTIES AND CONDITIONS RESPECTING THE PRODUCT, WHETHER EXPRESS OR IMPLIED, INCLUDING BUT NOT LIMITED TO, ANY IMPLIED WARRANTY OR CONDITION OF MERCHANTABILITY OR FITNESS FOR A PARTICULAR PURPOSE, AND NO REPRESENTATIONS SHALL BE BINDING ON LGECI. LGECI DOES NOT AUTHORIZE ANY PERSON TO CREATE OR ASSUME FOR IT ANY OTHER WARRANTY OBLIGATION OR LIABILITY IN CONNECTION WITH THE PRODUCT. TO THE EXTENT THAT ANY WARRANTY OR CONDITION IS IMPLIED BY LAW, IT IS LIMITED TO THE WARRANTY PERIOD SET OUT ABOVE. UNDER NO CIRCUMSTANCES SHALL LGECI, THE MANUFACTURER OR DISTRIBUTOR OF THE PRODUCT, BE LIABLE FOR ANY INCIDENTAL, CONSEQUENTIAL, SPECIAL, DIRECT, INDIRECT, PUNITIVE OR EXEMPLARY DAMAGES, INCLUDING, WITHOUT LIMITATION, LOSS OF GOODWILL, LOST PROFITS, LOSS OF ANTICIPATED PROFITS, LOST REVENUE, LOSS OF USE, OR ANY OTHER DAMAGE, WHETHER ARISING DIRECTLY OR INDIRECTLY FROM ANY CONTRACTUAL BREACH, FUNDAMENTAL BREACH, TORT OR OTHERWISE, OR FROM ANY ACTS OR OMISSIONS. LGECI'S TOTAL LIABILITY, IF ANY, SHALL NOT EXCEED THE PURCHASE PRICE PAID BY YOU FOR THE PRODUCT.

This Limited Warranty gives you specific legal rights. You may also have other rights that vary from province to province depending on applicable provincial laws. Any term of this Limited Warranty that

negates or varies any implied condition or warranty under provincial law is severable where it conflicts with such provincial law without affecting the remainder of this warranty's terms.

THIS LIMITED WARRANTY DOES NOT COVER:

- Service trips to i) deliver, pick up, or install or; educate on how to operate the Product; ii) correct wiring; or iii) correct unauthorized repairs or installations of the Product;
- Damage or failure of the Product to perform during power failures and interrupted or inadequate electrical service;
- Damage or failure caused by leaky or broken water pipes, frozen water pipes, restricted drain lines, inadequate or interrupted water supply or inadequate supply of air;
- Damage or failure resulting from operating the Product in a corrosive atmosphere or contrary to the instructions outlined in the Product's owner's manual;
- Damage or failure to the Product caused by accidents, pests and vermin, lightning, wind, fire, floods, acts of God, or any other causes beyond the control of LGECI or the manufacturer;
- Damage or failure resulting from misuse, abuse, improper installation, repair, or maintenance of the Product. Improper repair includes use of parts not authorized or specified by LGECI. Improper installation or maintenance includes installation or maintenance contrary to the Product's owner's manual;
- Damage or failure caused by unauthorized modification or alteration of the Product, or if used for other than the intended household purpose/use of the Product, or damage or failure resulting from any water leakage due to improper installation of the Product;
- Damage or failure caused by incorrect electrical current, voltage or plumbing codes;
- Damage or failure caused by use that is other than normal household use, including, without limitation, commercial or industrial use, including use in commercial offices or recreational facilities, or as otherwise outlined in the Product's owner's manual;
- Damage or failure caused by the use of any accessories, components or cleaning products, including, without limitation, that are not approved/authorized by LGECI;
- Damage or failure caused by transportation and handling, including scratches, dents, chips and/or other damage to the finish of the Product, unless such damage results from defects in materials or workmanship and is reported to LGECI within one (1) week of delivery of the Products;
- Damage or missing items to any display, open box, refurbished or discounted Product;
- Refurbished Product or any Product sold "As Is", "Where Is", "With all Faults", or any similar disclaimer;
- Products with original serial numbers that have been removed, altered or cannot be readily determined at the discretion of LGECI;
- Increases in utility costs and additional utility expenses in any way associated with the Product;
- Replacement of light bulbs, filters, fuses or any other consumable parts;
- Costs associated with removal and/or reinstallation of the Product for repairs;
- Noises associated with normal operation and failure to follow instructions found in the use and care and installation guides or operating the unit in an unsuitable environment will not be covered under this warranty.
- Coverage for "in Home" repairs, for products in-warranty, will be provided if the Product is within a 150 km radius from the nearest authorized service center (ASC), as determined by LG Canada. If your Product is located outside a 150 km radius from a ASC, as determined by LG Canada, it will be your responsibility to bring the Product, at your sole expense, to the ASC for in-warranty repair.

All costs and expenses associated with the above excluded circumstances, listed under the heading, This Limited Warranty Does Not Cover, shall be borne by the consumer.

TO OBTAIN WARRANTY SERVICE AND ADDITIONAL INFORMATION, PLEASE CALL OR VISIT OUR WEBSITE:

Call 1-888-542-2623 and select the appropriate option from the menu, or visit our website at <http://www.lg.com>

PROCEDURE FOR RESOLVING DISPUTES:

EXCEPT WHERE PROHIBITED AT LAW, ALL DISPUTES BETWEEN YOU AND LG ARISING OUT OF OR RELATING IN ANY WAY TO THIS LIMITED WARRANTY OR THE PRODUCT SHALL BE RESOLVED EXCLUSIVELY THROUGH BINDING ARBITRATION, AND NOT IN A COURT OF GENERAL JURISDICTION. EXCEPT WHERE PROHIBITED AT LAW, YOU AND LG BOTH IRREVOCABLY AGREE TO WAIVE THE RIGHT TO A JURY TRIAL AND TO BRING OR PARTICIPATE IN A CLASS ACTION.

Definitions. For the purposes of this section, references to “LG” mean LG Electronics Canada, Inc., its parents, subsidiaries and affiliates, and each of their officers, directors, employees, agents, beneficiaries, predecessors in interest, successors, assigns and suppliers; references to “dispute” or “claim” shall include any dispute, claim or controversy of any kind whatsoever (whether based in contract, tort, statute, regulation, ordinance, fraud, misrepresentation or any other legal or equitable theory) arising out of or relating in any way to the sale, condition or performance of the product or this Limited Warranty.

Notice of Dispute. In the event you intend to commence an arbitration proceeding, you must first notify LG in writing at least 30 days in advance of initiating the arbitration by sending a letter to LGECI Legal Team at 20 Norelco Drive, North York, Ontario, Canada M9L 2X6 (the “Notice of Dispute”). You and LG agree to engage in good faith discussions in an attempt to amicably resolve your claim. The notice must provide your name, address, and telephone number; identify the product that is the subject of the claim; and describe the nature of the claim and the relief being sought. If you and LG are unable to resolve the dispute within 30 days of LG’s receipt of the Notice of Dispute, the dispute shall be resolved by binding arbitration in accordance with the procedure set out herein. You and LG both agree that, during the arbitration proceeding, the terms (including any amount) of any settlement offer made by either you or LG will not be disclosed to the arbitrator until the arbitrator determines the dispute.

Agreement to Binding Arbitration and Class Action Waiver. Upon failure to resolve the dispute during the 30 day period after LG’s receipt of the Notice of Dispute, you and LG agree to resolve any claims between you and LG only by binding arbitration on an individual basis, unless you opt out as provided below, or you reside in a jurisdiction that prevents full application of this clause in the circumstances of the claims at issue (in which case if you are a consumer, this clause will only apply if you expressly agree to the arbitration). To the extent permitted by applicable law, any dispute between you and LG shall not be combined or consolidated with a dispute involving any other person’s or entity’s product or claim. More specifically, without limitation of the foregoing, except to the extent such a prohibition is not permitted at law, any dispute between you and LG shall not under any circumstances proceed as part of a class or representative action. Instead of arbitration, either party may bring an individual action in small claims court, but that small claims court action may not be brought on a class or representative basis except to the extent this prohibition is not permitted at law in your province or territory of jurisdiction as it relates to the claims at issue between you and LG.

Arbitration Rules and Procedures. To begin arbitration of a claim, either you or LG must make a written demand for arbitration. The arbitration will be private and confidential, and conducted on a simplified and expedited basis before a single arbitrator chosen by the parties under the provincial or territorial commercial arbitration law and rules of the province or territory of your residence. You must also send a copy of your written demand to LG at LG Electronics, Canada, Inc., Attn: Legal Department- Arbitration, 20 Norelco Drive, North York, Ontario M9L 2X6. This arbitration provision is governed by your applicable provincial or territorial commercial arbitration legislation. Judgment may be entered on the arbitrator’s award in any court of competent jurisdiction. All issues are for the arbitrator to decide, except that, issues relating to the scope and enforceability of the arbitration provision and to the arbitrability of the dispute are for the court to decide. The arbitrator is bound by the terms of this provision.

Governing Law. The law of the province or territory of your purchase shall govern this Limited Warranty and any disputes between you and LG except to the extent that such law is preempted by or inconsistent with applicable federal or provincial/territorial law. Should arbitration not be permitted for any claim, action, dispute or controversy between you and LG, you and LG attorn to the exclusive jurisdiction of the courts of the province or territory of your purchase for the resolution of the claim, action, dispute or controversy between you and LG.

Fees/Costs. You do not need to pay any fee to begin an arbitration. Upon receipt of your written demand for arbitration, LG will promptly pay all arbitration filing fees unless you seek more than \$25,000 in damages, in which case the payment of these fees will be governed by the applicable arbitration rules. Except as otherwise provided for herein, LG will pay all filing, administration and arbitrator fees for any arbitration initiated in accordance with the applicable arbitration rules and this arbitration provision. If you prevail in the arbitration, LG will pay your attorneys’ fees and expenses as long as they are reasonable, by

considering factors including, but not limited to, the purchase amount and claim amount. Notwithstanding the foregoing, if applicable law allows for an award of reasonable attorneys' fees and expenses, an arbitrator can award them to the same extent that a court would. If the arbitrator finds either the substance of your claim or the relief sought in the demand is frivolous or brought for an improper purpose (as measured by the applicable laws), then the payment of all arbitration fees will be governed by the applicable arbitration rules. In such a situation, you agree to reimburse LG for all monies previously disbursed by it that are otherwise your obligation to pay under the applicable arbitration rules. Except as otherwise provided for, LG waives any rights it may have to seek attorneys' fees and expenses from you if LG prevails in the arbitration.

Hearings and Location. If your claim is for \$25,000 or less, you may choose to have the arbitration conducted solely (1) on the basis of documents submitted to the arbitrator, (2) through a telephonic hearing, or (3) by an in-person hearing as established by the applicable arbitration rules. If your claim exceeds \$25,000, the right to a hearing will be determined by the applicable arbitration rules. Any in-person arbitration hearings will be held at the nearest, most mutually-convenient arbitration location available within the province or territory in which you reside unless you and LG both agree to another location or agree to a telephonic arbitration.

Severability and Waiver. If any portion of this Limited Warranty (including these arbitration procedures) is unenforceable, the remaining provisions will continue in full force and effect to the maximum extent permitted by applicable law. Should LG fail to enforce strict performance of any provision of this Limited Warranty (including these arbitration procedures), it does not mean that LG intends to waive or has waived any provision or part of this Limited Warranty.

Opt Out. You may opt out of this dispute resolution procedure. If you opt out, neither you nor LG can require the other to participate in an arbitration proceeding. To opt out, you must send notice to LG no later than 30 calendar days from the date of the first consumer purchaser's purchase of the product by either (i) sending an e-mail to optout@lge.com, with the subject line: "Arbitration Opt Out;" or (ii) calling 1-800-980-2973. You must include in the opt out e-mail or provide by telephone: (a) your name and address; (b) the date on which the product was purchased; (c) the product model name or model number; and (d) the serial number (the serial number can be found (i) on the product; or (ii) online by accessing https://www.lg.com/ca_en/support/repair-service/schedule-repair and clicking on "Find My Model & Serial Number").

In the event that you "Opt Out", the law of the province or territory of your residence shall govern this Limited Warranty and any disputes between you and LG except to the extent that such law is preempted by or inconsistent with applicable federal or provincial/territorial law. Should arbitration not be permitted for any claim, action, dispute or controversy between you and LG, you and LG agree to attorn to the exclusive jurisdiction of the courts of the province or territory of your residence for the resolution of the claim, action, dispute or controversy between you and LG.

You may only opt out of the dispute resolution procedure in the manner described above (that is, by e-mail or telephone); no other form of notice will be effective to opt out of this dispute resolution procedure. Opting out of this dispute resolution procedure will not affect the coverage of the Limited Warranty in any way, and you will continue to enjoy the full benefits of the Limited Warranty. If you keep this product and do not opt out, then you accept all terms and conditions of the arbitration provision described above.

Conflict of Terms. In the event of a conflict or inconsistency between the terms of this Limited Warranty and the End User License Agreement ("EULA") in regards to dispute resolution, the terms of this Limited Warranty shall control and govern the rights and obligations of the parties and shall take precedence over the EULA.



MANUAL DEL PROPIETARIO

LAVADORA

Lea el manual del propietario detenidamente previo a operar el electrodoméstico y manténgalo al alcance para futuras referencias.

ESPAÑOL

WM3600H*A



MFL71693706
Rev.00_061220

www.lg.com

Copyright © 2020 LG Electronics Inc. Todos los derechos reservados

ÍNDICE

3 INSTRUCCIONES IMPORTANTES DE SEGURIDAD

- 3 LEA TODAS LAS INSTRUCCIONES ANTES DE UTILIZAR
- 3 MENSAJES DE ADVERTENCIA
- 6 MENSAJES DE PRECAUCIÓN

7 DESCRIPCIÓN GENERAL DEL PRODUCTO

- 7 Características del producto

9 INSTALACIÓN

- 9 Antes de la instalación
- 10 Elección de la ubicación adecuada
- 11 Desempacando y removiendo el material de transporte
- 12 Conexión de las mangueras de entrada de agua
- 13 Conexión de la manguera de desagüe
- 14 Nivelación de la lavadora
- 16 Revisión final de la instalación

17 FUNCIONAMIENTO

- 17 Antes de utilizarlo
- 18 Clasificación de prendas
- 19 Carga de la lavadora
- 20 Agregado de productos de limpieza
- 23 Panel de control
- 26 Ciclos de lavado
- 30 Modificadores de ciclo
- 30 Opciones y funciones adicionales

33 FUNCIONES INTELIGENTES

- 33 Uso de la aplicación LG ThinQ
- 36 Función Smart Diagnosis™ (Diagnóstico Inteligente)

37 MANTENIMIENTO

- 37 Limpieza regular
- 37 Mantenimiento periódico
- 41 Cuidado en climas fríos

43 SOLUCIÓN DE PROBLEMAS

- 43 Antes de llamar al servicio técnico

53 GARANTÍA LIMITADA

- 53 EE. UU.

INSTRUCCIONES IMPORTANTES DE SEGURIDAD

LEA TODAS LAS INSTRUCCIONES ANTES DE UTILIZAR

Mensajes de seguridad

Su seguridad y la de los demás son muy importantes.

Tanto en este manual como en el equipo, hemos proporcionado muchos mensajes de seguridad importantes. Siempre debe leer y respetar todos los mensajes de seguridad.



Este es el símbolo de alerta de seguridad.

Este símbolo le advierte sobre posibles riesgos que pueden ocasionar lesiones o la muerte a usted o a otros. El símbolo de alerta de seguridad siempre estará acompañado de las palabras "ADVERTENCIA" o "PRECAUCIÓN" y seguido de un mensaje de seguridad importante.

Estos términos significan lo siguiente:



ADVERTENCIA

El incumplimiento de las instrucciones podría causarle la muerte o lesiones graves.



PRECAUCIÓN

El incumplimiento de las instrucciones podría causarle lesiones o daños al producto.

Todos los mensajes de seguridad le indicarán cuáles son los peligros potenciales, cómo reducir la posibilidad de lesiones y qué podría suceder si no sigue las instrucciones.

MENSAJES DE ADVERTENCIA

ADVERTENCIA

- Para disminuir el riesgo de explosiones, incendios, descargas eléctricas, quemaduras, lesiones o muerte para las personas que usen este artefacto, siga las precauciones básicas, incluidas las siguientes:

Instalación

- Cumpla con todos los procedimientos de seguridad del sector recomendados, incluido el uso de guantes de manga larga y gafas de seguridad.
- Nunca intente operar este artefacto si se encuentra dañado, si no funciona correctamente, si no está ensamblado por completo o si tiene piezas faltantes o rotas, incluido un cable o enchufe dañado.
- Antes de ser utilizado, este artefacto debe ser correctamente instalado, conforme a lo descrito en este manual.
- Para reducir el riesgo de lesiones graves o muerte, siga todas las instrucciones de instalación.
- Consulte las INSTRUCCIONES DE INSTALACIÓN para obtener información detallada sobre los procedimientos de conexión a tierra. Las instrucciones de instalación se suministran junto con el artefacto para ser consultadas por el instalador. Si el artefacto se traslada a una nueva ubicación, asegúrese de que lo revise y lo vuelva a instalar personal de servicio calificado.
- El traslado o la instalación del artefacto requieren de dos o más personas.
- No instale el artefacto en lugares húmedos.
- Almacene e instale el artefacto donde no esté expuesto a temperaturas bajo cero ni a la intemperie.
- Este artefacto no ha sido diseñado para ser usado en embarcaciones o instalaciones móviles, tales como casas rodantes, remolques o aeronaves.
- Mantenga los materiales de empaque fuera del alcance de los niños. Los materiales de empaque pueden ser peligrosos para los niños. Corren riesgo de asfixia.

4 INSTRUCCIONES IMPORTANTES DE SEGURIDAD

- Destruya el cartón, la bolsa de plástico y los demás materiales de empaque luego de desempacar el artefacto. Estos materiales podrían utilizarlos los niños para jugar. Las cajas de cartón cubiertas con tapetes, colchas o láminas plásticas pueden convertirse en cámaras herméticas.
- El artefacto debe ser instalado y conectado a tierra por personal de servicio calificado, de acuerdo con los códigos locales.
- Cuando traslade o instale el aparato, tenga especial cuidado en no apretar, aplastar o dañar el cable de alimentación.
- Debe conectarse a un circuito de alimentación de clasificación y tamaño adecuados y debidamente protegido para evitar la sobrecarga eléctrica.
- Debe posicionar este artefacto cerca de una fuente de suministro eléctrico.
- Desconecte el cable de alimentación, el fusible del hogar o el interruptor de corriente antes de instalar o reparar el artefacto.
- El cable de alimentación de este aparato está equipado con un enchufe de 3 clavijas (conexión a tierra) que se conecta con un tomacorriente estándar de 3 clavijas (tierra) para minimizar la posibilidad de descarga eléctrica de este aparato.
- Por ninguna razón debe cortar o quitar la tercera clavija (tierra) del cable de alimentación.
- Use mangueras nuevas cuando conecte la lavadora al suministro de agua. No reutilice mangueras viejas.

FUNCIONAMIENTO

- Lea todas las instrucciones antes de usar el artefacto y consérvelas.
- Use el artefacto únicamente para el fin previsto.
- Si el producto ha estado sumergido en el agua, en agua estancada o en un área anegada, no entre en contacto con el producto y comuníquese de inmediato con un Centro de información al cliente de LG Electronics para recibir instrucciones antes de reanudar el uso.
- Si detecta un sonido extraño, olor a quemado o a químico, o humo provenientes del artefacto, desconéctelo de inmediato y contáctese con un Centro de Información al Cliente de LG Electronics.
- Bajo ciertas condiciones, podría producirse gas hidrógeno en un sistema de agua caliente que no ha sido utilizado por dos semanas o más. EL GAS HIDRÓGENO ES EXPLOSIVO. Si el sistema de agua caliente no se ha usado durante ese período de tiempo, abra todas las llaves de agua caliente y deje que fluya varios minutos antes de usar el artefacto. Esto eliminará el gas hidrógeno acumulado. Dado que el gas hidrógeno es inflamable, no fume ni use ninguna llama abierta durante este proceso.
- No introduzca las manos en la lavadora si la cuba, el tambor, el agitador o cualquier pieza interior del artefacto se encuentra en movimiento. Antes de cargar, descargar o agregar artículos, presione Inicio/ Pausa y espere que la cuba o el tambor se detengan por completo antes de introducir las manos en el interior.
- Este artefacto no ha sido diseñado para ser utilizado por personas con capacidades físicas, sensoriales o mentales disminuidas (incluidos niños) o que no cuenten con la experiencia o los conocimientos necesarios para operarlo, salvo que una persona responsable de su seguridad les brinde la supervisión o la instrucción pertinente en cuanto al uso del artefacto.
- No permita que niños o mascotas jueguen con el electrodoméstico, sobre o dentro de éste. Es necesaria la supervisión cuando el electrodoméstico es utilizado cerca de niños o mascotas.
- Mantenga los productos de lavandería lejos del alcance de los niños. Para evitar lesiones a las personas, preste atención a todas las advertencias que figuran en las etiquetas de los productos.
- Repare o reemplace de inmediato todos los cables de alimentación deshilachados o dañados de otra forma. No use un cable que exhiba roturas o abrasión en su longitud o en sus extremos.
- Nunca desconecte el artefacto tirando del cable de alimentación. Sujete siempre con firmeza el enchufe y tire derecho para extraerlo del tomacorriente.
- No use un cable de extensión ni un adaptador con este artefacto.
- No sujete el cable de alimentación ni toque los controles del artefacto con las manos húmedas.
- No modifique ni extienda el cable de alimentación.

- Si se daña el cable de electricidad, solo el fabricante está autorizado para reemplazarlo, o bien su agente de servicio técnico o una persona de calificación similar para prevenir riesgos.
- No coloque prendas aceitosas o grasosas, candelas o materiales inflamables encima del artefacto.
- Mantenga el área debajo de los artefactos y sus alrededores libre de materiales combustibles (pelusa, papel, trapos, etc.), gasolina, productos químicos y otros vapores o líquidos inflamables.
- No almacene ni use gasolina u otros líquidos o vapores inflamables cerca de este artefacto ni de ningún otro.
- No mezcle cloro con amoníaco o ácidos, como por ejemplo, vinagre. Siga las instrucciones del envase cuando utilice productos de lavandería. Su uso incorrecto puede producir gases venenosos, los cuales pueden ocasionar lesiones graves o la muerte.
- Nunca utilice productos químicos agresivos, limpiadores abrasivos ni solventes para limpiar la lavadora. Estos productos arruinarán el acabado.
- No lave prendas que hayan sido previamente limpiadas, lavadas o manchadas con gasolina, solventes de limpieza en seco, aceite vegetal o de cocina u otras sustancias inflamables o explosivas, ni prendas a las cuales se haya sumergido en estos productos, ya que los mismos emiten vapores que pueden inflamarse o explotar.
- No agregue gasolina, solventes de limpieza en seco ni otras sustancias explosivas o inflamables al agua del lavado. Estas sustancias emiten vapores que pueden inflamarse o explotar.
- En el caso de que se produzca una fuga de gas (gas propano, gas licuado de petróleo, etc.), no ponga en funcionamiento este artefacto ni ningún otro. Abra una puerta o una ventana para ventilar el área de inmediato.
- No utilice indebidamente los controles.
- Asegure la manguera de drenaje de forma segura en su lugar a manera de evitar inundaciones.
- No maltrate la puerta, no se sienta ni se pare sobre ella.
- Verifique siempre el interior del electrodoméstico para detectar objetos extraños.
- No permita que agua, blanqueador u otros líquidos permanezcan dentro del tambor durante largos períodos de tiempo. Esto podría corroer el tambor o provocar moho u olores.

Mantenimiento

- No repare ni reemplace ninguna parte del electrodoméstico. Todas las reparaciones deben ser realizadas por personal de servicio calificado a menos que se recomiende específicamente en este manual del propietario. Utilice sólo piezas de fábrica autorizadas.
- Desconecte el artefacto del suministro eléctrico antes de limpiarlo o de realizar cualquier tipo de mantenimiento que pueda realizar el usuario. Colocar los controles en la posición de apagado no desconecta el artefacto del suministro eléctrico.
- Quite el polvo o los materiales extraños de las clavijas del enchufe de alimentación.
- No desarme ni repare el artefacto por su cuenta.
- Quite la puerta antes de sacar de servicio o desechar el artefacto para evitar el riesgo de que niños o animales pequeños queden atrapados adentro.
- Asegúrese de que la tapa o el cajón del dispensador se encuentren siempre cerrados cuando no se les estén colocando productos de lavandería.

Instrucciones de conexión a tierra

- La conexión inadecuada del conductor de conexión a tierra puede resultar en riesgo de choque eléctrico. Pregunte a un electricista calificado o al personal de servicio si no está seguro si el artefacto está adecuadamente conectado a tierra. No modifique el enchufe que viene con el artefacto. Si no cabe en el contacto, pida que un electricista calificado instale un contacto apropiado.
- El artefacto debe estar conectado a tierra. En caso de funcionamiento defectuoso o avería, la conexión a tierra reduce el riesgo de choque eléctrico al establecer una ruta de menor resistencia para la corriente

eléctrica. El artefacto viene equipado con un cable eléctrico que tiene un conductor para conexión a tierra y un enchufe con conexión a tierra. El enchufe debe ser conectado a un contacto apropiado que esté instalado y conectado a tierra de acuerdo con todos los códigos y ordenanzas locales.

MENSAJES DE PRECAUCIÓN

PRECAUCIÓN

- Para reducir el riesgo de lesiones leves o moderadas a personas, el mal funcionamiento o daño al producto o propiedad cuando use este producto, siga las precauciones básicas, incluido lo siguiente:
-

Instalación

- Instale el producto sobre un piso firme y nivelado.

FUNCIONAMIENTO

- No coloque ningún objeto encima del artefacto.
- Cierre las llaves de agua y desconecte el artefacto si este no será usado por un periodo de tiempo prolongado, por ejemplo, durante las vacaciones.
- SIEMPRE siga las instrucciones para cuidado de los tejidos suministradas por el fabricante.
- Use suavizantes o productos para eliminar la electricidad estática solamente según las recomendaciones del fabricante.
- No combine productos de lavandería en una misma carga a menos que este uso se especifique en la etiqueta
- No toque el agua de desagüe, ya que podría estar caliente.
- Si las mangueras de drenaje y de entrada de agua se congelan en invierno, descongélelas antes de utilizar el electrodoméstico.
- No almacene ni vierta limpiadores, blanqueadores (blanqueador con cloro, blanqueador oxigenado, etc.) ni detergentes líquidos encima del artefacto. Si lo hace, podría ocasionar corrosión, decoloración o daño de la superficie del artefacto.
- Prendas o artículos impermeables o resistentes al agua deben ser lavados solamente en el ciclo Impermeables. (Los ejemplos incluyen: prendas resistentes al agua, fundas para colchones, ropa para exteriores, tapetes plásticos, etc.) El uso de otro ciclo podría producir una herida o causarle daños a la lavadora, a las prendas, las paredes, el piso y a objetos circundantes debido a la vibración anormal.

GUARDE ESTAS INSTRUCCIONES

DESCRIPCIÓN GENERAL DEL PRODUCTO

Características del producto

Las ilustraciones en esta guía pueden diferir de los componentes y accesorios reales, los cuales están sujetos a cambios sin previo aviso por parte del fabricante a fin de introducir mejoras en el producto.

⚠ ADVERTENCIA

- Para su seguridad y para prolongar la vida útil del producto, use solo componentes autorizados. El fabricante no se hace responsable del mal funcionamiento del producto, los daños a la propiedad o las lesiones corporales causadas por el uso de componentes, partes o productos no autorizados adquiridos por separado.

Vista frontal

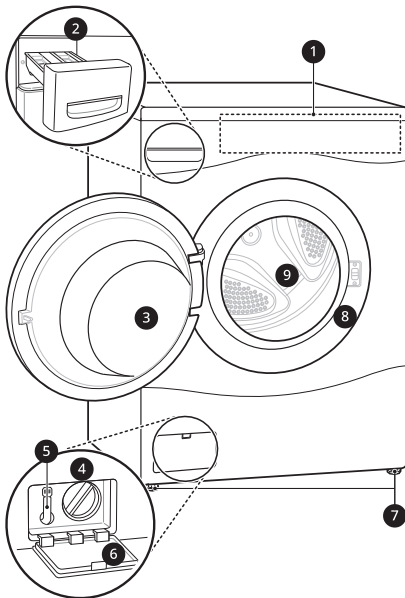

- ❶ Panel de control
- ❷ Bandeja Dispensadora de Detergente
- ❸ Puerta
- ❹ Filtro de la Bomba de Drenaje
- ❺ Manguera de Drenaje
- ❻ Cubierta del Filtro de la Bomba de Drenaje
- ❼ Patas de nivelación
- ❽ Sello de la Puerta
- ❾ Tambor

Vista trasera

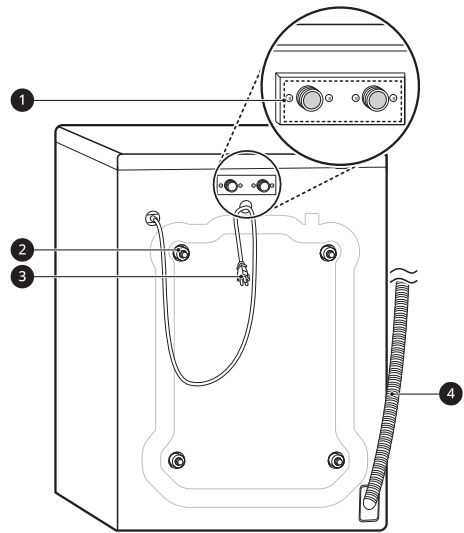

- ❶ Entradas de Agua
- ❷ Tornillos de Transporte
- ❸ Cable de Alimentación
- ❹ Manguera de Drenaje

Accesorios

Accesorios incluidos

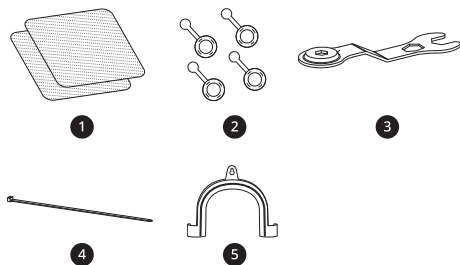

- ❶ Apoyos antideslizantes
- ❷ Tapones de agujeros
- ❸ Llave
- ❹ Correa
- ❺ Codo de soporte (para asegurar la manguera de desagüe)

Accesorios requeridos



- ❶ Mangueras de agua caliente y fría

Accesorios Opcionales

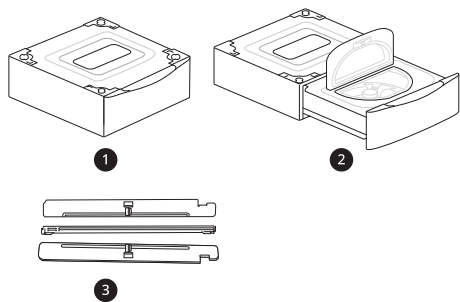

- ❶ Pedestal
- ❷ Pedestal lavador
- ❸ Kit de Apilamiento

Especificaciones del producto

Modelo	WM3600H*A
Requisitos Eléctricos	120 V CA, 60 Hz
Presión de agua mín./máx.	20 - 120 psi (138 - 827 kPa)
Dimensiones (ancho X altura X profundidad)	27" X 39" X 30 1/4" (70 cm X 99 cm X 77 cm)
Profundidad máxima con la puerta abierta	55" (139.6 cm)
Peso neto	198.4 lb (90 kg)
Velocidad máx. de centrifugado	1300 RPM

INSTALACIÓN

Antes de la instalación

Descripción general de la instalación

Lea las siguientes instrucciones de instalación inmediatamente después de adquirir esta lavadora o transportarla a otra ubicación.

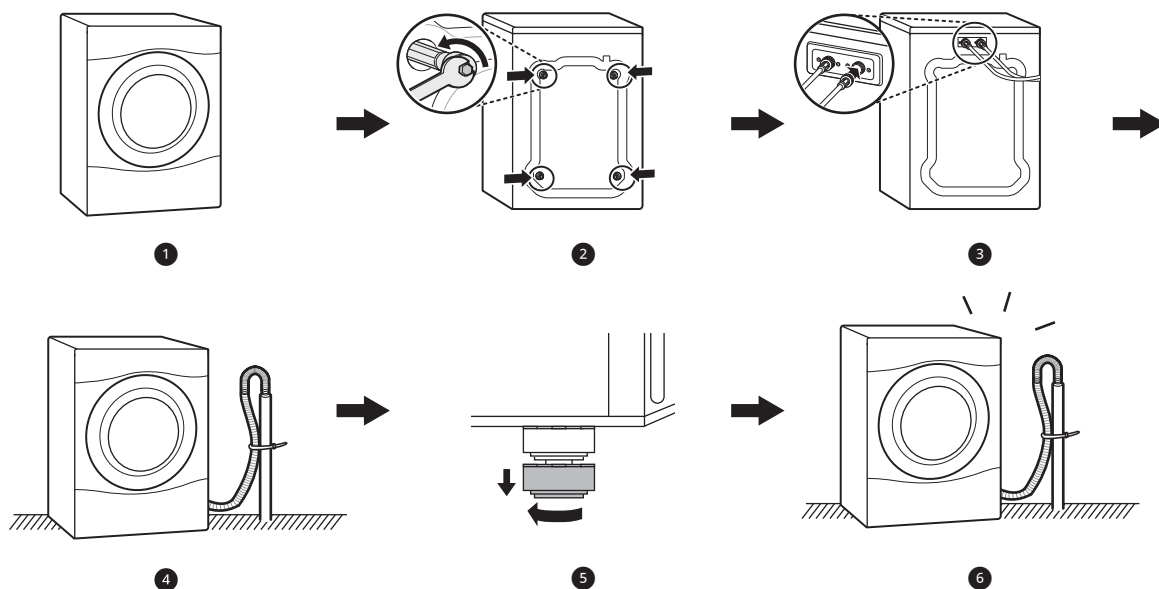

- 1 Elección de la ubicación adecuada
- 2 Desempacando y removiendo el material de transporte
- 3 Conexión de las mangueras de ingreso
- 4 Conexión de la manguera de desagüe
- 5 Nivelación de la lavadora
- 6 Revisión final de la instalación

⚠ ADVERTENCIA

- El traslado o la instalación del artefacto requieren de dos o más personas. El incumplimiento de estas instrucciones podría causar lesiones.
- Almacene e instale el artefacto donde no esté expuesto a temperaturas bajo cero ni a la intemperie. El incumplimiento de esta advertencia puede causar daños al producto o las piezas, lesiones graves, incendios, descargas eléctricas o la muerte.
- Conecte la lavadora a tierra adecuadamente, de acuerdo con todos los códigos y las ordenanzas vigentes. El incumplimiento de esta advertencia puede causar lesiones graves, incendios, descargas eléctricas o la muerte.
- Para garantizar una circulación de aire adecuada, no bloquee la abertura grande que se encuentra en la parte inferior de la lavadora con tapetes u otros materiales.
- No retire la clavija de conexión a tierra del cable de alimentación. No utilice un adaptador ni un cable de extensión. Conecte a un tomacorriente de 3 clavijas con conexión a tierra. El incumplimiento de esta advertencia puede causar lesiones graves, incendios, descargas eléctricas o la muerte.

⚠ ADVERTENCIA

- Ciertas piezas internas no tienen conexión a tierra en forma intencional y pueden presentar un riesgo de descarga eléctrica sólo durante la reparación. Personal de servicio: No toque la bomba, la válvula, el motor o el tablero de control cuando el aparato esté recibiendo energía.

Herramientas necesarias



- ❶ Pinzas
- ❷ Destornillador de hoja plana
- ❸ Nivel

Elección de la ubicación adecuada

Revise los siguientes requisitos para la ubicación de instalación antes de instalar la lavadora.

- Permita que quede espacio suficiente entre los muros y la lavadora para su instalación.
- Asegúrese de que el piso esté limpio, seco y libre de polvo, suciedad, agua y aceite, para que las patas de nivelación no se deslicen fácilmente. Las patas de nivelación que se muevan o deslicen por el piso podrían contribuir a un exceso de vibración y ruido.
- Si el piso es demasiado flexible, refuércelo para volverlo más rígido. Si el piso no es sólido, se podrían generar vibraciones y ruidos intensos.
- Si es necesario utilizar un depósito de drenaje, tenga mucho cuidado de seguir las instrucciones que se proporcionan con este y asegúrese de que ajustar las patas niveladoras para que tengan un contacto firme y uniforme con el depósito. El uso de depósitos de drenaje y la falta de nivelación adecuada de la lavadora pueden aumentar la vibración y el ruido durante el funcionamiento.

Tomacorriente

- El tomacorriente debe estar ubicado dentro de un perímetro de **60 pulgadas (1.5 m)** de cualquiera de los lados de la lavadora.
- Coloque la lavadora de manera que se pueda acceder fácilmente al tomacorriente y el enchufe.
- No sobrecargue el tomacorriente conectándole más de un artefacto.

- El tomacorriente debe estar conectado a tierra según las regulaciones y los códigos de cableado eléctrico vigentes.
- Utilice un interruptor de circuito o un fusible de acción retardada.
- Es responsabilidad y obligación personal del propietario de la lavadora contar con un tomacorriente adecuado que haya sido instalado por personal de servicio calificado.

Suelo

- Para minimizar ruidos y vibraciones, instale la lavadora en un piso sólidamente construido y a nivel, que pueda brindar soporte a la lavadora sin hundirse ni rebotar.
- La lavadora debe instalarse en un suelo firme para minimizar la vibración que se produce durante el centrifugado. Los pisos de concreto son los más indicados, pero un piso de madera es suficiente, siempre y cuando esté construido conforme a las normas de la FHA.
- El piso debajo de la lavadora no debe tener una pendiente de más de 1 pulgada (2.5 cm) de lado a lado o de adelante hacia atrás.
- No se recomienda su instalación en superficies cubiertas por alfombras o baldosas blandas.
- Nunca instale la lavadora sobre una plataforma ni sobre una estructura de soporte débil.

Instalación en el piso

Para garantizar el espacio suficiente para las mangueras de entrada de agua y desagüe, y para la circulación de aire, deje un espacio de, al menos, **1 pulgada (2.5 cm)** a cada lado y **4 pulgadas (10 cm)** detrás de la lavadora. Asegúrese de tener en cuenta las molduras de pisos, puertas o muros que podrían aumentar los espacios necesarios.

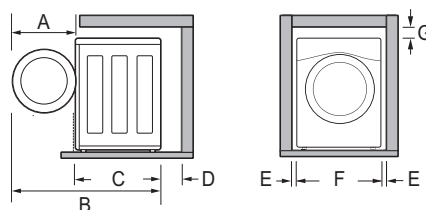

Dimensiones y espacios	
A	24 3/4" (62.6 cm)
B	55" (139.6 cm)
C	30 1/4" (77 cm)
D	4" (10 cm)
E	1" (2.5 cm)
F	27" (70 cm)
G	1/4" (0.5 cm)

Instalación Apilada o de Pedestal

La lavadora puede apilarse debajo de un secador o sobre un pedestal o pedestal lavador.

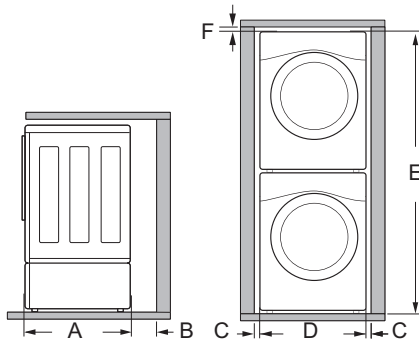

Dimensiones y espacios	
A	30 1/4" (77 cm)
B	4" (10 cm)
C	1" (0.5 cm)
D	27" (70 cm)
E	77 1/2" (196.8 cm)
F	1/4" (0.5 cm)

NOTA

- Consulte las instrucciones que se suministran junto con el kit de pedestal opcional antes de instalar el electrodoméstico sobre el pedestal.
- No utilice una bandeja de drenaje con una instalación de pedestal o pedestal lavadora, ya que ésta podría bloquear el cajón. Utilizar una bandeja de drenaje podría causar un incremento en el ruido y la vibración durante la operación.

Desempacando y removiendo el material de transporte

Retire todo el material de transporte de la lavadora para su adecuada operación y verifique que no haya daños provocados durante el envío.

⚠ PRECAUCIÓN

- No remover el material de transporte podría causar ruido y vibración excesiva.

Desempacando el material de transporte

* Esta característica solamente está disponible en algunos modelos.

Levante la lavadora de la base de espuma.

- Luego de quitar el cartón y el material de transporte, levante la lavadora de la base de espuma.
- Asegúrese de que el soporte plástico del tambor ❶* salga junto con la base y que no quede atascado en la parte inferior de la lavadora.
- Si debe recostar la lavadora para retirar la base de cartón ❷, siempre proteja sus lados y recuéstela con cuidado sobre un costado. No apoye la lavadora sobre su parte posterior o frontal.

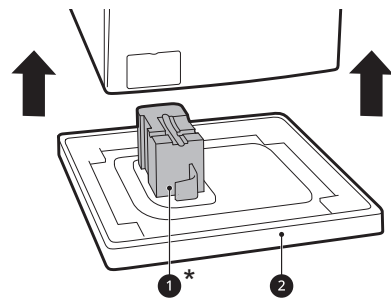

Retirando el material de transporte

- 1 Retire los ensambles de pernos.
 - Comenzando por los dos pernos de transporte de la parte inferior ❸, use la llave incluida para aflojar por completo los 4 pernos de transporte haciéndolos girar a la izquierda.

- Retire los ensambles de pernos (pernos y retenedores) moviéndolos suavemente a medida que tira de ellos.

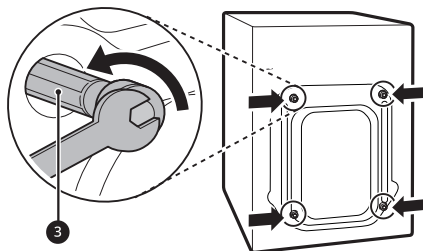

2 Instale los tapones para los orificios.

- Localice los cuatro tapones para orificios **4** incluidos en el paquete de accesorios o sujetos a la parte posterior de la lavadora. Instálelos en los orificios de los ensambles de pernos.

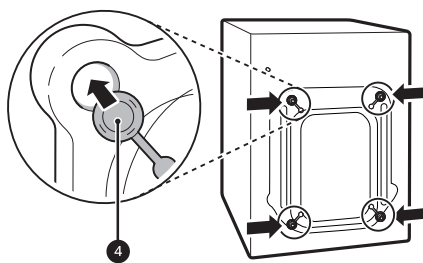

⚠ PRECAUCIÓN

- Después de retirarlos, guarde los ensambles de pernos para uso futuro. Para evitar el daño de los componentes internos, no transporte la lavadora sin volver a instalar los pernos de transporte. Si no se retiran los pernos de transporte y los retenedores, existe la posibilidad de que se produzcan ruidos y vibraciones intensas que podrían provocar daños permanentes en la lavadora.

NOTA

- El cable de alimentación está sujeto al lado posterior de la lavadora con un perno de transporte para contribuir a evitar que se haga funcionar el artefacto con los pernos de transporte colocados.

Conexión de las mangueras de entrada de agua

Para evitar costosos daños por agua, compre e instale mangueras de entrada de agua nuevas al instalar la lavadora.

⚠ ADVERTENCIA

- No apriete extremadamente ni cruce los conectores de las mangueras. Al apretar en extremo o cruzar los conectores se pueden dañar las válvulas o los acoplamientos y esto podría resultar en fugas y daños a la propiedad.
- No reutilice mangueras viejas. Utilice únicamente nuevas mangueras al instalar la lavadora. Las mangueras viejas podrían tener fugas o estallar causando una inundación y daño a la propiedad. Contacte al Centro de Información al Cliente de LG para asistencia en la compra de mangueras.

NOTA

- Revise periódicamente las mangueras para detectar rajaduras, fugas y desgaste, y reemplácelas cada cinco años.
- No estire intencionalmente las mangueras de agua y asegúrese de que no estén apretadas, aplastadas ni plegadas por otros objetos.
- La presión del suministro de agua debe ser de entre **20 psi y 120 psi (138 – 827 kPa)**. Si la presión del suministro de agua es mayor que **120 psi**, se debe instalar una válvula reductora.
- El calentador de agua caliente se debe ajustar para que suministre agua a una temperatura de **120 °F a 135 °F (48 °C a 57 °C)** a fin de controlar las temperaturas de lavado de manera correcta.
- No almacene ni instale la lavadora en un sitio sujeto a temperaturas de congelamiento. Esto puede provocar daños a las mangueras de entrada de agua y a los mecanismos internos de la lavadora. Si esta estuvo expuesta a temperaturas de congelamiento antes de su instalación, déjela a temperatura ambiente durante varias horas antes de utilizarla y compruebe que no presente fugas antes de ponerla en funcionamiento.
- No utilice mangueras de prevención de inundaciones con dispositivos de cierre automático, ya que pueden activarse durante el llenado y evitar que se llene la lavadora de manera adecuada.

Cómo conectar las mangueras de ingreso de agua

- 1 Verifique los conectores y los sellos. Inspeccione el conector roscado de cada manguera y asegúrese de que cada una cuente con un sello de goma **1** colocado en cada extremo para evitar fugas.

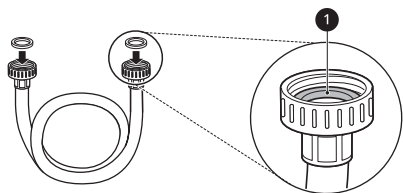

- 2** Conecte las mangueras de suministro de agua.
- Conecte las mangueras de suministro de agua a las llaves de paso de agua caliente y fría y apriete las conexiones manualmente y luego utilice unas pinzas para apretarlas otros 2/3 de vuelta.
 - Conecte la manguera azul a la llave de agua fría y la manguera roja a la llave de agua caliente.

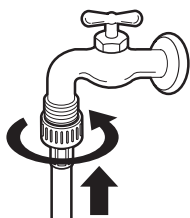

- 3** Enjuague las mangueras de entrada.
- Una vez que las mangueras estén conectadas, abra las llaves de agua y enjuague toda sustancia extraña, como suciedad, arena y aserrín.
 - Drene el agua en una cubeta y verifique la temperatura del agua a fin de asegurarse de haber conectado las mangueras a las llaves de paso correctas.

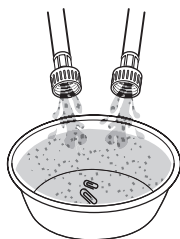

- 4** Fije las mangueras de entrada a la parte posterior de la lavadora.
- Fije la manguera de entrada de agua caliente a la entrada de agua caliente de la parte posterior de la lavadora. Fije la manguera de entrada de agua fría a la entrada de agua fría de la parte posterior de la lavadora.
 - Ajuste los conectores para asegurarlos bien. Abra por completo ambas llaves y verifique

que no existan fugas en los dos extremos de las mangueras.

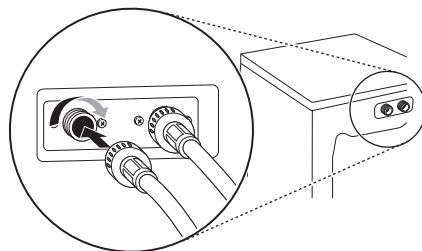

Conexión de la manguera de desagüe

La manguera de drenaje puede ser instalada utilizando un tubo independiente o un lavabo. Usted puede elegir el método que necesite.

⚠ ADVERTENCIA

- La manguera de desagüe siempre debe estar conectada adecuadamente. Si la conexión de la manguera de desagüe no se encuentra bien asegurada, podrían producirse inundaciones y daños a la propiedad.

NOTA

- El desagüe debe estar instalado según las regulaciones y los códigos locales vigentes.
- Asegúrese de que la manguera de desagüe no se encuentre estirada, pellizcada, aplastada ni plegada.
- No instale la manguera de drenaje con el extremo a una altura menor a **29.5 pulgadas (75 cm)** o mayor a **96 pulgadas (244 cm)** en relación al fondo de la lavadora, ni a más de **60 pulgadas (152 cm)** de ella.
- Nunca genere un sello hermético entre la manguera y el desagüe con una cinta u otros medios. Si no existe una trampa de aire, se puede extraer el agua desde el tambor, lo que perjudicará el rendimiento del lavado/enjuague o dañará la ropa.

Uso de un tubo independiente para drenaje

- 1** Enganche el extremo de la manguera en el codo de soporte.
- Conecte el codo de soporte **1** a unas **4 pulgadas (10 cm)** del extremo de la manguera de desagüe. Si la manguera de desagüe se extiende a más de **4 pulgadas**

(10 cm) del extremo del codo de soporte, podrían proliferar microorganismos o moho dentro de la lavadora.

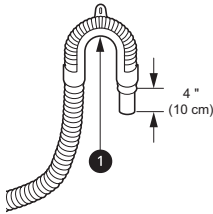

2 Inserte el extremo de la manguera de desagüe en el tubo independiente.

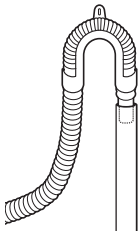

3 Utilice la correa proporcionada para fijar la manguera de desagüe en su lugar.

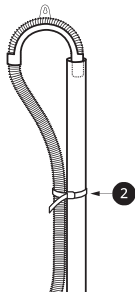

4 Si las válvulas de agua y de drenaje están integradas a la pared, ajuste la manguera de desagüe a unas de las mangueras de agua con la correa proporcionada (lado acanalado hacia dentro).

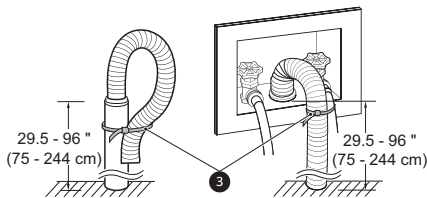

Uso del lavabo para drenaje

- Enganche el extremo de la manguera en el codo de soporte.
 - Conecte el codo de soporte 1 a unas 4 pulgadas (10 cm) del extremo de la manguera de desagüe. Si la manguera de desagüe se extiende a más de 4 pulgadas (10 cm) del extremo del codo de soporte, podrían proliferar microorganismos o moho dentro de la lavadora.

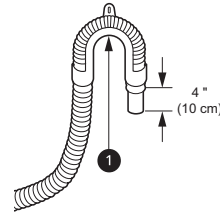

2 Cuelgue el extremo de la manguera de desagüe sobre el borde del lavabo.

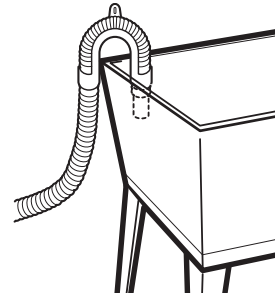

3 Utilice la correa proveída para asegurar la manguera de desagüe en su lugar.

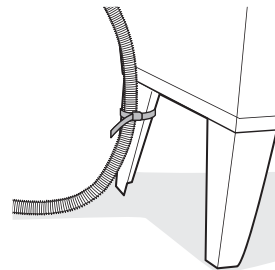

Nivelación de la lavadora

El tambor de la lavadora gira a velocidades muy altas. Para minimizar el ruido, la vibración y los movimientos no deseados, la lavadora debe instalarse en una superficie sólida y nivelada.

⚠ PRECAUCIÓN

- Si se utiliza la lavadora sin nivelarla, se pueden producir excesos de vibración y ruido y causar problemas en su funcionamiento.
- Ajuste las patas de nivelación solo en la medida necesaria para nivelar la lavadora. Si las patas de nivelación tienen más altura de la necesaria, se pueden producir vibraciones.

NOTA

- Antes de instalar la lavadora, asegúrese de que el piso esté limpio, seco y libre de polvo, suciedad, agua y aceite, para que las patas de la lavadora no se deslicen fácilmente. Las patas que se muevan o deslicen por el piso podrían provocar un exceso de vibración y ruido.

Nivelación de la lavadora

- 1 Coloque la lavadora en su ubicación final.
 - Tenga especial cuidado en no pellizcar, estirar o aplastar las mangueras de suministro de agua y drenaje. Si tiene un nivel de carpintero **1**, puede usarlo para comprobar que la lavadora esté nivelada. La pendiente bajo la lavadora no debe superar **1 pulg.**, y los 4 patas de nivelación deben estar firmemente apoyadas en el suelo.

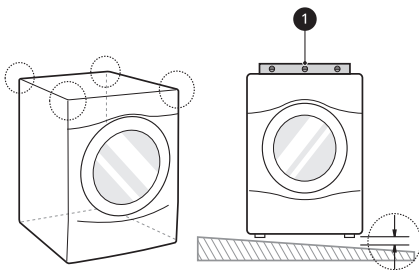

- 2 Ajuste las patas de nivelación.
 - Gire las 4 patas de nivelación en una dirección para subir la lavadora y en la otra dirección para bajarla.

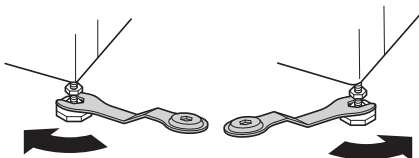

- 3 Verifique el nivel nuevamente.
 - Empuje o sacuda los bordes superiores de la lavadora de manera suave para asegurarse de que no se balancee. Si la lavadora se balancea, reajuste las patas de nivelación.
- 4 Ajuste las tuercas de seguridad **2**.
 - Gire las tuercas hacia la izquierda y apriételas cuando la lavadora esté nivelada.



Uso de apoyos antideslizantes

Si instala la lavadora sobre una superficie resbaladiza, puede que esta se mueva a causa de la vibración excesiva. Una nivelación incorrecta puede resultar en un mal funcionamiento debido al ruido y la vibración. Si esto sucede, instale los apoyos antideslizantes debajo de las patas de nivelación y ajuste el nivel.

- 1 Limpie el suelo antes de colocar los apoyos antideslizantes.
 - Utilice un paño limpio para limpiar y quitar cualquier objeto extraño o humedad. Si la superficie sigue húmeda, los apoyos antideslizantes podrían resbalarse.
- 2 Ajuste el nivel tras colocar la lavadora en el área de instalación.
- 3 Coloque el lado adhesivo **3** del apoyo antideslizante sobre el suelo.
 - Es más efectivo instalar las almohadillas antideslizantes debajo de las patas niveladoras frontales. Si es difícil instalar las almohadillas antideslizantes debajo de las patas frontales, instálelas debajo de las patas posteriores.

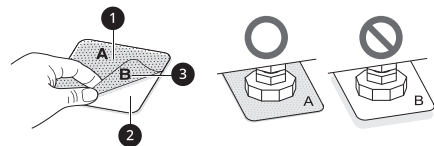

- 1 Este lado hacia arriba
- 2 Retire la parte de atrás

- 4** Vuelva a comprobar la nivelación de la lavadora.
- Empuje o sacuda los bordes superiores de la lavadora de manera suave para asegurarse de que no se balancee. Si la lavadora se balancea, vuelva a nivelarla.

Revisión final de la instalación

Conexión al suministro eléctrico

Enchufe la lavadora en un tomacorriente de 3 clavijas de **120 VCA, 60 Hz** clavijas con conexión a tierra.

ADVERTENCIA

- No utilice cables o enchufes de alimentación gastados o dañados. Reemplácelos o repárelos de inmediato. No hacerlo podría provocar un accidente mortal, un incendio, descarga eléctrica o problemas en el funcionamiento del aparato.
- No modifique el enchufe y el cable de alimentación proporcionados con el artefacto. No los dañe cuando instale o traslade la lavadora. Si se producen daños, puede provocar muerte, incendios, descargas eléctricas o mal funcionamiento del artefacto.
- Asegúrese de que el artefacto esté conectado a tierra.
- Conecte este artefacto a un tomacorriente con conexión a tierra acorde a su clasificación antes del uso. No hacerlo podría provocar un incendio, descarga eléctrica o problemas en el funcionamiento del aparato.
- No dañe ni corte la clavija de conexión a tierra del cable de alimentación. Si lo hace podría provocar un accidente mortal, un incendio, descarga eléctrica o problemas en el funcionamiento del aparato.
- La conexión incorrecta del conductor de puesta a tierra del equipo puede provocar un riesgo de descarga eléctrica. Consulte con un electricista calificado o técnico de servicio si tiene dudas sobre si el aparato está debidamente conectado a tierra. Si el enchufe no encaja en el tomacorriente, haga que un electricista calificado instale un tomacorriente adecuado.
- El artefacto y el tomacorriente deben estar ubicados de manera tal que se pueda acceder al enchufe fácilmente.
- No utilice adaptadores ni cables de extensión. De hacerlo podría provocar un accidente mortal,

lesiones graves, un incendio, descarga eléctrica o problemas en el funcionamiento del aparato.

- Para un mejor rendimiento, conecte el aparato en una toma de corriente individual exclusiva. Esto ayuda a evitar la sobrecarga de los circuitos eléctricos de la casa, lo que podría causar un peligro de incendio por sobrecalentamiento de los cables.
- Si fuera necesario, utilice un enchufe de 3 clavijas (conexión a tierra), nuevo y homologado por UL, con una clasificación no menor a la del circuito derivado. No utilice un cable de extensión de una longitud mayor a 3 pies. El incumplimiento de estas advertencias puede resultar en lesiones graves, incendios, descargas eléctricas o la muerte.

Prueba de la lavadora

Verifique que la lavadora esté correctamente instalada y ejecute un ciclo de prueba.

- 1** Cargue la lavadora con 6 toallas de baño gruesas (aproximadamente, 6 libras).
- 2** Presione el botón de **Encendido/Apagado**.
- 3** Seleccione el ciclo **Rinse+Spin (Enjuague+Centrifugado)**.
- 4** Presione el botón de **Inicio/Pausa** para iniciar el ciclo de lavado.
- 5** Compruebe que se suministra agua, que la lavadora no se balancea ni vibra en exceso y que desagota bien durante el ciclo de centrifugado.

NOTA

- Si el agua se fuga durante su suministro, vea **Conexión de las mangueras de entrada de agua** para conectarlas correctamente.
- Si la lavadora se balancea y vibra en exceso, consulte la sección **Nivelación de la lavadora** para nivelarla de nuevo.
- Si el drenaje no funciona, vea **Conexión de la Manguera de Desagüe** para instalar la manguera apropiadamente.

FUNCIONAMIENTO

Antes de utilizarlo

ADVERTENCIA

- Para reducir el riesgo de incendios, descargas eléctricas o lesiones a las personas, lea las INSTRUCCIONES DE SEGURIDAD antes de operar este artefacto.

Funcionamiento general

- 1** Clasificación y carga de la lavadora.
 - Dependiendo de la necesidad, clasifique la ropa según tipo de tejido, nivel de suciedad, color o tamaño de la carga. Abra la puerta y cargue las prendas en la lavadora.
 - Si utiliza paquetes de detergente de un solo uso, colóquelos en el tambor antes de añadir sus prendas.
- 2** Agregue productos de limpieza.
 - Añada la cantidad apropiada de detergente de alta eficiencia (HE) al dispensador de detergente.
 - Si así lo desea, añada blanqueador o suavizante en las áreas apropiadas de la bandeja dispensadora.
 - No coloque paquetes de detergente líquido o en polvo en el dispensador.
- 3** Encendido de la lavadora
 - Presione el botón de **Encendido/Apagado** para encender la lavadora.
- 4** Seleccione un ciclo
 - Gire la perilla selectora de ciclos o presione los botones de ciclos repetidamente hasta que se seleccione el ciclo deseado.
 - La configuración predeterminada de temperatura de lavado, velocidad de centrifugado, nivel de suciedad y opción se muestran para el ciclo seleccionado.
 - El ciclo **Normal** debe seleccionarse para cambiar sus configuraciones predeterminadas.
 - Presionar el botón de **Inicio/Pausa** sin seleccionar un ciclo inmediatamente inicia el ciclo **Normal** con las configuraciones predeterminadas.
- 5** Ajuste la Configuración.
 - Pueden modificarse las configuraciones predeterminadas del ciclo seleccionado, si así se lo desea, con los botones de opción y de modificación de ciclo.
 - No todas las modificaciones y opciones están disponibles para todos los ciclos. Sonará una alarma diferente y el indicador LED no se enciende si la selección no está permitida.
- 6** Comienzo del ciclo.
 - Presione el botón de **Inicio/Pausa** para iniciar el ciclo. La puerta se traba y la lavadora se agita brevemente sin agua para medir el peso de la carga.
 - Si el botón de **Inicio/Pausa** no es presionado dentro de cierto tiempo, la lavadora se apagará automáticamente y todas las configuraciones se perderán.

7 Fin de ciclo.

- Una melodía sonará cuando el ciclo haya finalizado. Remueva inmediatamente las prendas de la lavadora para reducir las arrugas.
- Verifique alrededor del sello de la puerta cuando retire la ropa lavada y busque si no han quedado objetos pequeños atrapados en el sello.

NOTA

- La lavadora centrifuga el lavado de manera que le permite utilizar menos agua mientras satura completamente las prendas. Es normal que no pueda ver agua durante el ciclo de lavado.
 - Si la temperatura o el nivel de agua dentro de la máquina son demasiado altos, la puerta no se desbloqueará cuando presione el botón de **Inicio/Pausa**, y la función **Add Item (Añadir Prendas)** no estará disponible (en modelos en los que aplique). Para detener un ciclo y drenar el agua completamente, apague y encienda el aparato, y luego seleccione **Rinse+Spin (Enjuague+Centrifugado)**.
-

Clasificación de prendas

PRECAUCIÓN

- Las prendas o los artículos impermeables o resistentes al agua se deben lavar solo en el ciclo **Bedding**. (Entre los ejemplos se incluyen prendas resistentes al agua, fundas para colchones, prendas para exteriores y tapetes de plástico). Si se utiliza otro ciclo, se pueden producir lesiones personales o daños a la lavadora, a las prendas, a las paredes, al piso y a los objetos circundantes, debido a la vibración anormal.
 - Retire el relleno de las almohadas y cojines antes de lavar las fundas. Si no lo hace, se puede provocar una vibración excesiva y dañar la lavadora, las prendas, los objetos circundantes, las paredes y el suelo.
-

Conjuntos de prendas similares

Para obtener los mejores resultados de lavado y para reducir la posibilidad de daños en las prendas, agrupe la ropa en cargas de prendas de características similares.

Si se mezclan telas o niveles de suciedad diferentes, el resultado puede ser un lavado deficiente, transferencia de colores, decoloración, daño de las prendas o que se desprendan pelusas. Las telas deben clasificarse en grupos tal como se describe a continuación.

Colores

Clasifique las prendas según su color. Lave la ropa oscura separada de los colores claros o blancos. Si se mezclan prendas de colores oscuros con prendas de colores claros, puede ocurrir transferencia de tinte o decoloración en la ropa más clara.

Nivel de suciedad

La ropa muy sucia debe lavarse junta. Si lava las prendas con menor suciedad en la misma carga que la ropa muy sucia, el resultado puede ser un lavado deficiente de las prendas de menor suciedad.

Tipo de tela

Las prendas delicadas no deben mezclarse con las prendas de telas más resistentes o pesadas. Si lava prendas de telas pesadas con ropa delicada, el resultado puede ser un lavado deficiente de la ropa de tela pesada y es posible que se dañen las prendas delicadas.

Telas que atraen o despiden pelusa

Algunas telas atraen pelusa y esta se adhiere a ellas, mientras que otras despiden pelusas en el proceso de lavado. Evite mezclar en la misma carga ropa a la que se adhiere la pelusa con ropa que despidan pelusas.











Mezclar estos materiales puede tener como resultado que, en las prendas que atraen pelusa, se formen bolitas y que estas ropas se llenen de pelusa. (Por ejemplo, prenda a la que se le adhiere la pelusa: suéter tejido; prenda que despiden pelusas: toalla de tejido esponjoso).

Cómo clasificar las prendas

Por Colores	Por nivel de suciedad	Por tela	Según la pelusa
Blancas	Muy sucias	Delicadas	Que despiden pelusa
Colores claros	Normal	Cuidado fácil	Que recoge pelusa
Oscuras	Ligera	Resistente	

Etiquetas de cuidado de las prendas

Muchas prendas incluyen una etiqueta de cuidado de telas. Utilizando el siguiente cuadro, ajuste el ciclo y las opciones a manera de cuidar de sus prendas de acuerdo a las recomendaciones del fabricante.

Categoría	Etiqueta	Indicaciones
 Lavado		Lavado a mano
		Lavado en lavadora, Ciclo normal
		Configuración Planchado permanente/Resistente a las arrugas (que tiene un rociado fresco o frío antes de un centrifugado más lento)
		Suave/Delicado (agitación lenta y/o menor tiempo de lavado)
		No lavar
		No retorcer
Temperatura del agua	...	Caliente
	..	Tibia
	.	Fría
 Símbolos sobre blanqueador		Cualquier blanqueador (cuando sea necesario)
		Solo blanqueador sin cloro (cuando sea necesario)
		No usar blanqueador

Carga de la lavadora

los objetos circundantes, debido a la vibración anormal.

PRECAUCIÓN

- Las prendas o los artículos impermeables o resistentes al agua se deben lavar solo en el ciclo **Bedding**. (Entre los ejemplos se incluyen prendas resistentes al agua, fundas para colchones, prendas para exteriores y tapetes de plástico). Si se utiliza otro ciclo, se pueden producir lesiones personales o daños a la lavadora, a las prendas, a las paredes, al piso y a

Consejos generales

- Revise y vacíe los bolsillos. Los ganchos para papel, las monedas, los fósforos, etc., pueden dañar las prendas y la lavadora.
- Asegúrese de que los zípers y los ganchos de la ropa estén cerrados y amarre cualquier cordón para evitar que las prendas se enganchen o enreden.

- Para mejores resultados, trate previamente las áreas con manchas difíciles.
- Con un cepillo, quite el polvo, los pelos y la suciedad más densa de los artículos antes de lavarlos. El exceso de suciedad o arena puede raspar otras telas y causar un lavado deficiente.
- Para un mejor rendimiento, cargue la ropa como se muestra.

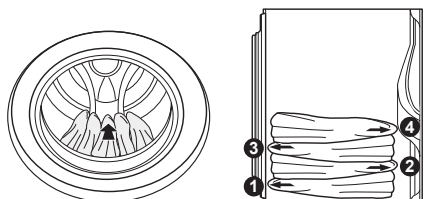

- No presione las prendas cuando las coloque en el tambor.
- Cargue la ropa floja y no llene excesivamente el tambor. Las prendas necesitan espacio para moverse y, así, limpiarse.
- Combine prendas grandes y pequeñas en el tambor. Primero, cargue la ropa más grande. Las prendas grandes no deben representar más de la mitad de la carga total.
- La lavadora puede estar llena por completo, pero el tambor no debe llenarse totalmente con prendas. La puerta de la lavadora debe poder cerrarse con facilidad.
- La lavadora no se llenará ni funcionará con la puerta abierta.

Artículos voluminosos

- Lave las prendas gruesas y voluminosas de manera individual. Las cobijas, los edredones y las colchas pesadas o las camas para mascotas pueden enredarse o provocar una carga desequilibrada si se combinan con otros artículos.

Prendas pequeñas

- No lave prendas pequeñas individualmente. Agregue suficientes prendas similares a la carga para evitar que quede desequilibrada.
- Lave las prendas pequeñas y livianas en una bolsa de malla. Las prendas pequeñas pueden quedar atrapadas en el impulsor al fondo del tambor, y los ganchos de los sostenes pueden engancharse en otras prendas o en el tambor.

Agregado de productos de limpieza

Acerca del uso de detergente

Esta lavadora está diseñada para ser usada únicamente con detergentes de alta eficiencia (HE).



- Los detergentes de alta eficiencia (HE) producen menos espuma, se disuelven mejor a fin de optimizar el rendimiento del lavado y el enjuague, y ayudan a mantener limpio el interior de la lavadora. El empleo de un detergente que no sea de alta eficiencia puede producir demasiada espuma y un mal desempeño, causando errores, fallas en los ciclos y daños a la lavadora.
- Puede que detergentes designados como Compatibles con HE no provean resultados óptimos.
- Para lograr un buen desempeño de lavado, siempre mida la cantidad de detergente usando el dispositivo de medición provisto por el fabricante del detergente. Para una carga promedio, use menos de la mitad del máximo recomendado. Use menos detergente para aguas blandas, ropas con poca suciedad o cargas reducidas.
- Preste atención especial al medir detergentes concentrados 2X y 3X porque incluso agregar solo un poco más de detergente podría provocar problemas.
- Nunca utilice una cantidad de detergente superior al máximo recomendado por el fabricante. Usar una cantidad excesiva de detergente puede producir demasiada espuma, un enjuague deficiente, acumulación de detergente en la ropa y acumulación de residuos que contribuyen a que se produzcan olores en la lavadora.
- No utilice más de un paquete de detergente de un solo uso en la lavadora. Utilizar demasiado detergente podría generar un exceso de espuma y afectar el rendimiento de lavado. Reduzca la cantidad de detergente o añada un enjuague extra si hay residuos de éste en los tejidos. Para

añadir un enjuague extra, seleccione la opción **Extra Rinse (Extra enjuague)**.

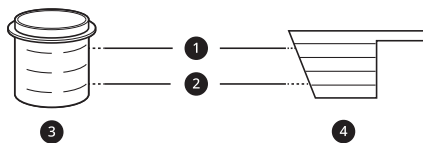

- 1 Línea de llenado máximo
- 2 Línea de llenado de carga promedio
- 3 Detergente líquido
- 4 Detergente en polvo

Paquetes de detergente de un solo uso

Coloque los paquetes de detergente en polvo o líquido en el tambor previo a cargar sus prendas. No coloque los paquetes en el dispensador.

Usando el Dispensador

Para agregar productos de limpieza al dispensador automático:

- 1 Abra la bandeja del dispensador.
- 2 Cargue los productos de lavandería en los compartimientos adecuados.
 - Siga las recomendaciones del fabricante cuando añada productos de limpieza.

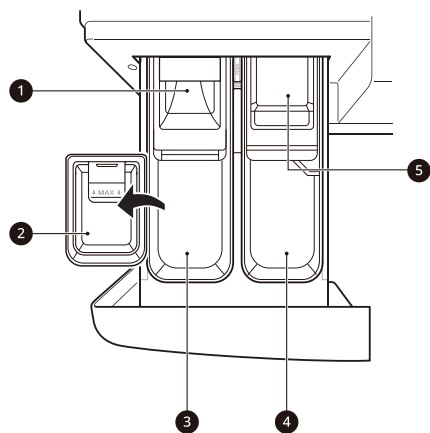

- 1 Compartimiento de detergente para pre-lavado (en algunos modelos)
- 2 Taza de detergente líquido
- 3 Compartimiento de detergente para lavado principal

- 4 Compartimiento de suavizante líquido
- 5 Compartimiento de blanqueador con cloro líquido

- 3 Cierre lentamente la bandeja dispensadora de detergente previo a iniciar el ciclo.
 - Cerrar la bandeja dispensadora de detergente con mucha fuerza puede causar el desbordamiento del detergente en otro compartimiento o que éste ingrese a la tina antes de lo programado.
 - Tenga cuidado de no prensar su mano al cerrar la bandeja.
 - Es normal que quede una pequeña cantidad de agua en los compartimientos del dispensador al final del ciclo.

⚠ PRECAUCIÓN

- No coloque ni almacene productos de lavandería, como detergente, blanqueador o suavizante líquido, en la parte superior de la lavadora. Estos productos pueden dañar los controles y el acabado de la lavadora.

Compartimiento de detergente para prelavado

Coloque detergente líquido o en polvo en este compartimiento cuando utilice la opción de **Pre-wash (Prelavado)**. Siempre utilice detergente de alta eficiencia (HE) en su lavadora.

- Cuando utilice la opción de **Pre-wash (Prelavado)**, es necesario cargar el detergente líquido para el lavado principal en el recipiente accesorio de detergente líquido del dispensador de lavado principal (cuando corresponda), para evitar que este ingrese junto con el detergente del prelavado.
- La cantidad de detergente que debe colocar para la opción de **Pre-wash (Prelavado)** es la mitad de la recomendada para el lavado principal. Por ejemplo, si para el ciclo de lavado principal se recomienda una medida de detergente, agregue 1/2 medida para la opción de **Pre-wash (Prelavado)**.

Compartimiento de detergente para lavado principal

En este compartimiento se coloca el detergente para lavadoras correspondiente al ciclo de lavado principal. En este compartimiento puede utilizarse tanto detergente líquido como en polvo.

- El detergente se agrega a la carga al inicio del ciclo. Siempre utilice detergente de alta eficiencia (HE) en su lavadora.
- No sobrepase la línea de llenado máximo. El uso de una cantidad excesiva de detergente puede ocasionar una acumulación de detergente en las prendas y en la lavadora.
- Puede agregar blanqueador protector de color líquido o en polvo en el compartimiento para el lavado principal junto con un detergente del mismo tipo. No mezcle polvos con líquidos.
- Si el dispensador tiene un accesorio y un recipiente de detergente líquido, siga estos pasos:
 - Asegúrese de que estén en su lugar al utilizar el detergente líquido.
 - Asegúrese de retirarlos cuando utilice detergente en polvo. Este detergente no ingresará a la lavadora si el accesorio y el recipiente de detergente líquido están en su lugar.
- Si utiliza un detergente que no se disuelve fácilmente o un detergente de alta viscosidad, éste dejará residuos y obstruirá el dispensador.

Compartimiento de blanqueador líquido

En este compartimiento se coloca el blanqueador líquido, que se dispensa automáticamente en el momento adecuado durante el ciclo de lavado. El dispensador se activa dos veces para asegurar que el blanqueador se dispense por completo. Si queda líquido en el dispensador después de la finalización del ciclo de lavado, se trata de agua, no de blanqueador.

ADVERTENCIA

- No mezcle cloro con amoníaco o ácidos, como por ejemplo vinagre o removedores de óxido o desincrustantes. La mezcla de productos químicos como los mencionados puede producir gases letales, que provocan lesiones graves o la muerte.

NOTA

- No coloque blanqueador en polvo en este compartimiento. El compartimiento de blanqueador está diseñado para dispensar únicamente blanqueador líquido. El blanqueador protector de color en polvo o líquido no se dispensará correctamente.
- Siga las recomendaciones del fabricante cuando añada blanqueador. Nunca añada más de una taza y no sobrepase la línea de llenado máximo o

el blanqueador se dispensará de inmediato y dañará las prendas. El uso excesivo de blanqueador también puede dañar las telas.

- Nunca vierta blanqueador con cloro líquido sin diluir directamente sobre la ropa o en el tambor. Puede dañar las prendas.
- No utilice blanqueador protector de color o blanqueador con oxígeno en el mismo ciclo de lavado en el que utilice blanqueador de cloro líquido.

Compartimiento de suavizante

En este compartimiento, se coloca el suavizante líquido, que se dispensa automáticamente durante el ciclo final de enjuague. Puede utilizarse tanto suavizante líquido como en polvo.

- No sobrepase la línea de llenado máximo. El uso de una cantidad excesiva de suavizante puede manchar las prendas u ocasionar una acumulación en las telas o en la lavadora.
- Diluya en agua caliente los suavizantes concentrados.
- Nunca vierta suavizante directamente sobre la ropa o en el tambor.

Panel de control

Funciones del panel de control

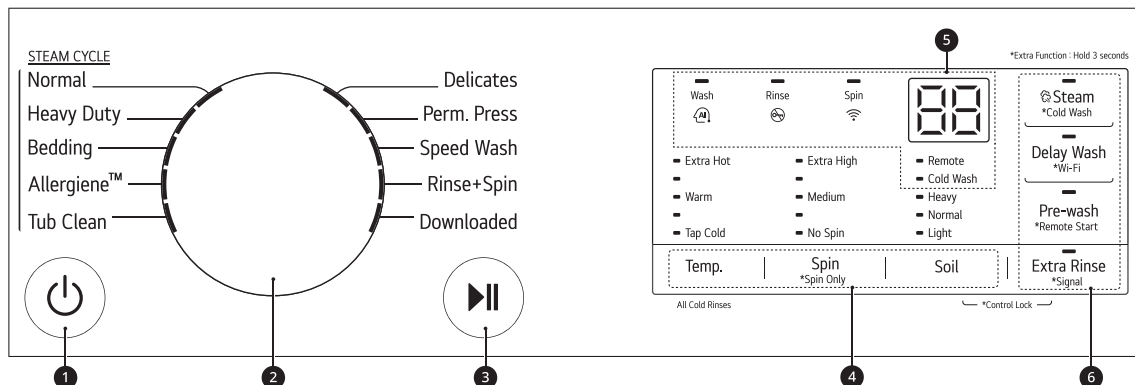

1 Botón de Encendido/Apagado

- Presione este botón para encender o apagar la lavadora.
- Presionar este botón durante un ciclo cancelará ese ciclo y se perderá cualquier configuración ingresada.
- La puerta se destrabará luego de una breve pausa.

NOTA

- Si queda agua en el tambor después de que se apaga la lavadora, el agua se drenará después de un tiempo de retraso. La lavadora puede reiniciarse en cualquier momento antes de que comience el drenaje. Sin embargo, una vez que comienza a drenarse el agua, se suspenderán todas las funciones hasta que se haya drenado el agua completamente y la lavadora se apague.

2 Perilla selectora de ciclos

- Gire esta perilla para seleccionar el ciclo deseado.
- Una vez haya seleccionado el ciclo deseado, se mostrarán las configuraciones predeterminadas en la pantalla. Estas configuraciones pueden ajustarse usando los **Botones modificadores de ciclo** en cualquier momento antes de iniciar el ciclo.

3 Botón de Inicio/Pausa

- Presione este botón para iniciar el ciclo seleccionado.
- Si la lavadora está funcionando, utilice este botón para pausar el ciclo sin perder las configuraciones actuales.

NOTA

- Si no se presiona el botón de **Inicio/Pausa** para iniciar el ciclo seleccionado, después de un tiempo de retraso la lavadora se apaga automáticamente y todas las configuraciones del ciclo se perderán. Se drenará el agua que quede en el tambor.

4 Botones modificadores de ciclo

- Use estos botones para ajustar las configuraciones de temperatura de lavado, velocidad del centrifugado y nivel de suciedad para el ciclo seleccionado.
- Las configuraciones actuales se muestran en la pantalla.
- Presione el botón para esa opción a fin de seleccionar otras configuraciones.

5 Pantalla de tiempo y estado

6 Botones de Opción y Función adicional

- Estos botones le permiten seleccionar opciones adicionales para el ciclo. Ciertos botones también le permiten activar funciones especiales al mantenerlos presionados por **3 segundos**.

Pantalla de tiempo y estado

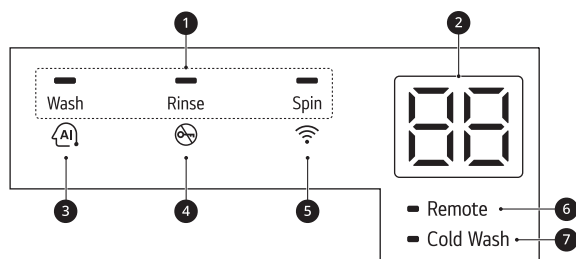

1 Indicadores de Estado del Ciclo

- Estos indicadores LED parpadean cuando un ciclo ha sido seleccionado para indicar las etapas a ejecutar.
- Cuando un ciclo está en progreso, el indicador LED de la etapa activa parpadea y los indicadores LED de las etapas restantes permanecen estables. Una vez que se completa una etapa, el indicador LED se apaga. Si se pausa un ciclo, el indicador LED de la etapa activa deja de parpadear.

2 Tiempo restante estimado

- Cuando un ciclo se ha seleccionado, el tiempo predeterminado para éste se mostrará. Este tiempo cambiará conforme se seleccionen modificadores u opciones.
- Si la pantalla muestra ---, entonces se mostrará el tiempo después de que el sensor de carga haya detectado el tamaño de la carga.
- El tiempo mostrado es sólo un estimado. Este tiempo está basado en condiciones de operación normal. Varios factores externos (tamaño de la carga, temperatura ambiente, temperatura del agua, etc.) podrían afectar el tiempo real.

NOTA

- Una vez el botón **Inicio/Pausa** ha sido presionado, la lavadora medirá el tamaño de la carga. El tiempo estimado podrá cambiar una vez el tamaño de la carga ha sido establecido.
- Si se configura el **Delay Wash (Lavado demorado)**, el tiempo de demora restante comienza una cuenta regresiva hasta que el ciclo inicie.

3 AI DD Indicator

- AI DD** proporciona las acciones de rotación del tambor adecuadas después de que se completa la detección de la carga.
- Este indicador se ilumina cuando:
 - se selecciona y opera el ciclo **Normal**, excepto cuando se selecciona el nivel de suciedad **Heavy (Muy Sucia)**.

4 Indicador de Bloqueo de Puerta

- Este indicador se enciende cuando el ciclo comienza y se bloquea la puerta.
- La luz indicadora permanecerá encendida hasta que el ciclo haya finalizado o sea pausado o detenido.

5 Indicador Wi-Fi

- Este indicador se enciende cuando el producto está conectado a una red Wi-Fi doméstica.

6 Indicador de inicio remoto

-
- Este indicador se enciende cuando la opción de **Remote Start (Inicio remoto)** está activada.

7 Indicador de Lavado frío

- Este indicador se enciende cuando la opción de **Cold Wash (Lavado frío)** está activada.

Ciclos de lavado

Los ciclos de lavado están diseñados para tipos específicos de cargas de lavado. Seleccione el ciclo que mejor se adapte al contenido de la carga para obtener el máximo rendimiento de lavado y del cuidado de la tela. Consulte la sección **Clasificación de prendas** para obtener los mejores resultados y siga las etiquetas de cuidado de las telas de sus prendas. Para ver una guía de símbolos de cuidado de telas, consulte la sección **Clasificación de prendas**.

Guía de ciclos

Gire la perilla o presione el botón para seleccionar el ciclo deseado. Cuando seleccione un ciclo de lavado, la luz correspondiente a dicho ciclo se encenderá.

NOTA

- Siempre que se haga referencia al peso de la carga, asuma **1 lb (0.45 kg)** = 1 toalla de baño gruesa (seca).

• Extra Hot	• Extra High
• Hot	• High
• Warm	• Medium
• Cold	• Low
• Tap Cold	• No Spin
Temp.	Spin

- El indicador de temperatura se ilumina cuando se selecciona una de las siguientes opciones: **Tap Cold (Más Fría)**, **Cold (Fría)**, **Warm (Tibia)**, **Hot (Caliente)** o **Extra Hot (Extra Caliente)**.
- El indicador de centrifugado se ilumina cuando se selecciona una de las siguientes opciones: **No Spin (No centrifugar)**, **Low (Bajo)**, **Medium (Medio)**, **High (Alta)** o **Extra High (Extra Fuerte)**.

Ciclo	Normal	
Descripción	Utilice este ciclo para lavar todas las prendas normales, como algodón, lino, camisas, jeans o cargas mixtas, excepto las de materiales delicados como lana o seda. <ul style="list-style-type: none"> • Presionar el botón Inicio/Pausa sin haber seleccionado un ciclo hará que el ciclo Normal inicie inmediatamente, utilizando la configuración predeterminada. 	
Temperatura de lavado	Predeterminado: Warm (Tibia)	Disponible: Todos
Velocidad de centrifugado	Predeterminado: High (Alta)	Disponible: Todos
Nivel de suciedad	Predeterminado: Normal	Disponible: Todos

Ciclo	Heavy Duty (Carga Pesada)	
Descripción	Este ciclo es para lavar ropa muy sucia, como telas de algodón, utilizando movimientos de lavado más potentes. <ul style="list-style-type: none"> • Cuando lave cargas grandes, habrá períodos breves de 2 minutos o más sin agitación. Estos períodos de remojo forman parte del diseño del ciclo y son normales. 	
Temperatura de lavado	Predeterminado: Warm (Tibia)	Disponible: Todos
Velocidad de centrifugado	Predeterminado: Extra High (Extra Fuerte)	Disponible: Todos
Nivel de suciedad	Predeterminado: Heavy (Muy Sucia)	Disponible: Todos

Ciclo	Bedding (Ropa de Cama)	
Descripción	Adecuado para lavar cobijas o artículos voluminosos que tengan dificultad para absorber agua, como almohadas, cobijas, edredones, sábanas o camas de mascotas. <ul style="list-style-type: none"> • No utilice este ciclo para lavar una carga mixta de ropa de cama y prendas que no lo sean. • No mezcle artículos grandes/voluminosos con prendas más pequeñas. • No lave artículos excesivamente voluminosos. Si los artículos grandes/voluminosos no entran fácilmente en la cuba, podrían no tener espacio suficiente para moverse durante el lavado. 	
Temperatura de lavado	Predeterminado: Warm (Tibia)	Disponible: Hot (Caliente), Warm (Tibia), Cold (Fría), Tap Cold (Más Fría)
Velocidad de centrifugado	Predeterminado: Medium (Medio)	Disponible: Medium (Medio), Low (Bajo), No Spin (No centrifugar)
Nivel de suciedad	Predeterminado: Normal	Disponible: Todos

Ciclo	Allergiene™	
Descripción	Este es un ciclo potente y de alta temperatura diseñado específicamente para reducir el contenido de ciertos alérgenos. <p>NOTA</p> <ul style="list-style-type: none"> • Seleccionando este ciclo, automáticamente incorpora vapor en el ciclo del lavado. • Con este ciclo, es posible reducir significativamente los alérgenos en la ropa de cama y las prendas. • Este ciclo ayuda a reducir las poblaciones de ácaros del polvo y los alérgenos. Debido al mayor consumo energético y a las altas temperaturas utilizadas, no se recomienda este ciclo para prendas de lana, seda, cuero ni ningún otro material delicado o sensible a las altas temperaturas. 	
Velocidad de centrifugado	Predeterminado: High (Alta)	Disponible: Todos

Ciclo	Tub Clean (Limpiando el Tambor)	
Descripción	Este es un ciclo especial diseñado para limpiar el interior de la lavadora.	

Ciclo	Delicates (Delicado)	
Descripción	Este ciclo se utiliza para lavar camisas/blusas, prendas de nailon, lencería o prendas finas o de encaje que se pueden dañar fácilmente. (menos de 8 lb (3,63 kg))	
Temperatura de lavado	Predeterminado: Cold (Fría)	Disponible: Warm (Tibia), Cold (Fría), Tap Cold (Más Fría)
Velocidad de centrifugado	Predeterminado: Medium (Medio)	Disponible: Medium (Medio), Low (Bajo), No Spin (No centrifugar)
Nivel de suciedad	Predeterminado: Normal	Disponible: Todos

Ciclo	Perm. Press (Planchado Permanente)	
Descripción	Utilice este ciclo para minimizar arrugas cuando lave manteles o prendas "que no se arrugan".	
Temperatura de lavado	Predeterminado: Warm (Tibia)	Disponible: Hot (Caliente), Warm (Tibia), Cold (Fría), Tap Cold (Más Fría)
Velocidad de centrifugado	Predeterminado: Medium (Medio)	Disponible: High (Alta), Medium (Medio), Low (Bajo), No Spin (No centrifugar)
Nivel de suciedad	Predeterminado: Normal	Disponible: Todos

Ciclo	Speed Wash (Velocidad de Lavado)	
Descripción	Lava rápidamente prendas ligeramente sucias y cargas pequeñas. Para una mayor eficiencia de lavado y enjuague, lave pequeñas cargas de 2-3 prendas ligeramente sucias. (menos de 3 lb (1,36 kg))	
	<ul style="list-style-type: none"> Utilice muy poco detergente en este ciclo. Para añadir un enjuague extra, utilice la opción Extra Rinse (Extra enjuague). 	
Temperatura de lavado	Predeterminado: Hot (Caliente)	Disponible: Hot (Caliente), Warm (Tibia), Cold (Fría), Tap Cold (Más Fría)
Velocidad de centrifugado	Predeterminado: Extra High (Extra Fuerte)	Disponible: Todos
Nivel de suciedad	Predeterminado: Light (Ligero)	Disponible: Todos

Ciclo	Rinse+Spin (Enjuague+Centrifugado)	
Descripción	<p>Seleccione este ciclo para enjuagar y centrifugar una carga por separado de un ciclo regular.</p> <ul style="list-style-type: none"> Esto puede ayudar a prevenir que manchas frescas se adhieran a las telas. Puede cambiar la velocidad de centrifugado presionando el botón de Spin (Centrifugado) repetidamente hasta seleccionar la velocidad deseada. 	

Ciclo	Downloaded (Small Load) (Ciclo Descargado (Poca ropa))	
Descripción	<p>Puede usar un teléfono inteligente para descargar un ciclo especial a esta posición de ciclo.</p> <ul style="list-style-type: none"> El ciclo predeterminado para esta posición es Small Load (Poca ropa), utilizado para cargas ligeramente sucias de pocos artículos. Este ciclo también está disponible para descargar. Consulte la aplicación LG ThinQ para ver los ciclos disponibles para descargar. 	
Temperatura de lavado	Predeterminado: Warm (Tibia)	Disponible: Hot (Caliente), Warm (Tibia), Cold (Fría), Tap Cold (Más Fría)
Velocidad de centrifugado	Predeterminado: High (Alta)	Disponible: Todos
Nivel de suciedad	Predeterminado: Normal	Disponible: Todos

Opciones disponibles

† Esta opción se incluye automáticamente en el ciclo y no se puede deseleccionar.

NOTA

- **Delay Wash (Lavado demorado)** y **Extra Rinse (Extra enjuague)** puede seleccionarse para cada ciclo en esta tabla.
- **Steam (Vapor)** y **Cold Wash (Lavado frío)** no se pueden seleccionar al mismo tiempo.

Ciclo	Steam (Vapor)	Cold Wash (Lavado frío)	Pre-wash (Prelavado)
Normal	●	●	●
Heavy Duty (Carga Pesada)	●	●	●
Bedding (Ropa de Cama)	●	●	●
Allergiene™	●†		
Delicates (Delicado)		●	●
Perm. Press (Planchado Permanente)		●	●
Speed Wash (Velocidad de Lavado)		●	
Rinse+Spin (Enjuague+Centrifugado)			
Downloaded (Ciclo Descargado) Predeterminado: Small Load (Poca ropa)		●	●

Modificadores de ciclo

Acerca de los botones modificadores

Cada ciclo tiene configuraciones predeterminadas que se seleccionan automáticamente. También puede personalizar estas configuraciones usando los botones modificadores de ciclo.

- Presione repetidamente el botón para el modificador deseado hasta que se encienda la luz indicadora para la configuración elegida.
- La lavadora automáticamente ajusta el nivel de agua según el tipo y el tamaño de la carga de ropa para obtener mejores resultados y una eficiencia máxima.
- Esta es una lavadora de alta eficiencia y los niveles de agua pueden ser mucho más bajos de lo esperado. Esto es normal y el rendimiento de lavado/enjuague no se verá afectado.

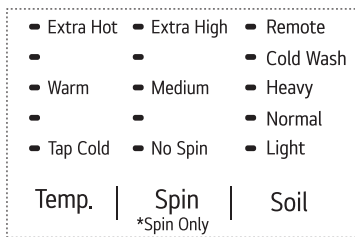

NOTA

- El indicador LED junto a la configuración se encenderá cuando se seleccione la configuración.
- Para proteger sus prendas, no todas las temperaturas de lavado, velocidades de centrifugado, niveles de suciedad u opciones están disponibles con cada ciclo.
- Sonará una alarma dos veces y no se encenderá el indicador LED si no se permite la configuración deseada para el ciclo seleccionado.
- Siga las instrucciones de las etiquetas de cuidado de las prendas para obtener mejores resultados.

Temp. (Temperatura)

Asegúrese de que la temperatura de lavado sea adecuada para el tipo de ropa que lavará.

- Presione el botón de **Temp. (Temperatura)** repetidamente para seleccionar la combinación de temperatura de lavado y enjuague para el ciclo seleccionado.

- Todos los enjuagues utilizan agua fría sin calentar.
- Los enjuagues con agua fría consumen menos energía. La temperatura real del enjuague frío depende de la temperatura del agua fría que sale de la llave.
- La lavadora cuenta con un elemento calentador para aumentar la temperatura del agua caliente en la configuración **Extra Hot (Extra Caliente)**. Esto proporciona un mejor rendimiento del lavado con configuraciones de calentador de agua normales.

Spin (Centrifugado)

Las velocidades de giro más altas extraen más agua de la ropa, reduciendo el tiempo de secado y ahorrando energía.

- Presione el botón **Spin (Centrifugado)** hasta seleccionar la velocidad deseada.
- Algunas telas, como las de las prendas delicadas, requieren que el centrifugado se realice con una velocidad menor.

Spin Only (Solo secado)

Esta opción gira la carga sin un ciclo de enjuague ni lavado. Esto resulta útil para centrifugar prendas lavables a mano.

- Presione el botón de **Spin (Centrifugado)** por 3 segundos.

Soil (Suciedad)

Ajustar el nivel de suciedad cambiará los tiempos de ciclo y/o las acciones de lavado.

- Presione el botón de **Soil (Suciedad)** repetidamente hasta seleccionar el nivel de suciedad deseado.
- La configuración de suciedad **Heavy (Muy Sucia)** podría aumentar la duración del ciclo. La configuración de suciedad **Light (Ligero)** podría reducir la duración del ciclo.

Opciones y funciones adicionales

La lavadora incluye varias opciones de ciclo adicionales para personalizar los ciclos a fin de que satisfagan sus necesidades.

- Seleccione la opción deseada después de elegir el ciclo y los ajustes que prefiere.

NOTA

- El LED de la opción se iluminará cuando esta se seleccione.

- Para proteger sus prendas, no se dispone de todas las opciones en cada ciclo.
- Sonará una alarma dos veces y no se encenderá el LED si no se permite la opción seleccionada para el ciclo que eligió.

Steam (Vapor)

Si se agrega esta opción a un ciclo de lavado, se obtiene una higiene superior. La utilización de vapor brinda a las telas los beneficios de limpieza de un lavado muy caliente.

- Es posible que durante los ciclos de vapor, este no pueda verse. Esto es normal. Demasiado vapor puede dañar las prendas.
- No utilice vapor con telas delicadas, como la lana y seda, o con telas que se decoloran fácilmente.

ADVERTENCIA

- No toque la puerta durante los ciclos de vapor. Su superficie puede calentarse mucho y puede provocar quemaduras graves. Espere a que se liberen las trabas de la puerta antes de abrirla.
- Nunca intente anular el mecanismo de cierre de la puerta ni intente introducir las manos en la lavadora durante un ciclo de vapor. El vapor puede causar quemaduras graves.

Uso de la opción de prelavado

Esta opción añade un prelavado (durante alrededor de **15 a 17 minutos**) para mejorar la limpieza de la ropa manchada o con alto nivel de suciedad.

NOTA

- Si selecciona **Pre-wash (Prelavado)** después de agregar detergente directamente en el tambor, es posible que el detergente desaparezca, reduciendo así el desempeño de lavado.

Remote Start (Inicio remoto)

Utilice un teléfono inteligente para controlar su lavadora de manera remota.

- Para obtener más información, consulte **FUNCIONES INTELIGENTES** en este manual.

Delay Wash (Lavado demorado)

Cuando haya seleccionado el ciclo y las otras configuraciones, presione el botón de **Delay Wash**

(Lavado demorado) para demorar el inicio del ciclo de lavado.

- Cada vez que presione el botón, aumenta el tiempo de demora en 1 hora, con un máximo de 19 horas.
- Una vez que haya establecido el tiempo de demora deseado, presione el botón de **Inicio/Pausa** para que comience a correr.

NOTA

- Si no se presiona el botón de **Inicio/Pausa** para iniciar el tiempo de demora, la lavadora se apagará automáticamente luego de un tiempo determinado y toda la configuración del ciclo se perderá.

Wi-Fi

Cuando la lavadora está conectada a una red Wi-Fi doméstica, el icono  en el panel de control está encendido.

- Para conectar la lavadora a la aplicación **LG ThinQ**, mantenga presionado el botón **Delay Wash (Lavado demorado)** durante 3 segundos.

Cold Wash (Lavado frío)

Presione el botón de **Cold Wash (Lavado frío)** para ahorrar energía mediante el uso de agua fría. Esto extenderá los tiempos de lavado y enjuague para mantener el rendimiento del lavado.

- El tiempo de lavado incrementará varios minutos con esta opción.
- Para obtener mejores resultados, lave solamente cargas pequeñas (menos de 8 lb) con esta opción.

Extra Rinse (Extra enjuague)

Esta opción añadirá un enjuague extra al ciclo seleccionado. Use esta opción para ayudar a eliminar el residuo de detergente o blanqueador de las telas.

- Presione el botón **Extra Rinse (Extra enjuague)** para añadir enjuagues adicionales al ciclo.

Control Lock (Bloqueo de Panel)

Utilice esta función para deshabilitar los controles. Esta función puede evitar que los niños cambien los ciclos o manejen esta lavadora.

NOTA

- La función no traba la puerta.
- Una vez que se establece esta función, todos los botones quedan bloqueados, excepto el botón de **Encendido/Apagado**.
- Cuando los controles están bloqueados, **CL** y el tiempo restante se muestran alternativamente en la pantalla durante el ciclo de lavado.
- Apagar la alimentación no restablecerá esta función. Debe desactivar esta función antes de poder acceder a otras opciones y funciones.

Bloqueando/Desbloqueando el Panel de Control

- 1** Conectar la alimentación.
 - 2** Mantenga presionado el botón de **Soil (Suciedad)** y **Extra Rinse (Extra enjuague)** por 3 segundos para activar/desactivar esta función.
- Cuando la función está desactivada, sonará una alarma y el tiempo restante para el ciclo actual volverá a aparecer en la pantalla.

Signal (Señal)

La lavadora emite una melodía cuando finaliza el ciclo de lavado. Los botones producen un sonido cada vez que se los presiona. Utilice esta opción para ajustar el volumen de la melodía y de los tonos de los botones.

- Para encender o apagar, presione el botón **Signal (Señal)**.

FUNCIONES INTELIGENTES

Uso de la aplicación LG ThinQ

La aplicación **LG ThinQ** le permite comunicarse con el electrodoméstico usando un teléfono inteligente.

Funciones de la aplicación LG ThinQ

- **Remote Start (Inicio remoto)**
 - Le permite controlar el electrodoméstico de manera remota desde la aplicación **LG ThinQ**.
- **Downloaded (Ciclo Descargado)**
 - Le permite descargar ciclos nuevos y especiales que no se encuentran incluidos en los ciclos estándar del electrodoméstico.
- **Asistente de Limpieza de Tina**
 - Esta función muestra la cantidad de ciclos restantes previo a que sea tiempo de ejecutar el ciclo de **Tub Clean (Limpiando el Tambor)**.
- **Monitoreo de energía**
 - Esta función lleva el control del consumo de energía de la lavadora afectada por determinados ciclos y opciones de lavado.
- **Smart Diagnosis™**
 - Esta función brinda información útil para diagnosticar y resolver problemas con el producto conforme a su patrón de uso.
- **Alertas Emergentes**
 - Cuando se completa el ciclo o el artefacto tiene problemas, recibirá un mensaje emergente.
- **Configuración**
 - Le permite ajustar varias opciones en el aparato y en la aplicación.

NOTA

- Si cambia de enrutador inalámbrico, proveedor de Internet o contraseña, borre el artefacto conectado de la aplicación **LG ThinQ** y proceda a conectarlo de nuevo.
- Esta información está actualizada en el momento de su publicación. La aplicación está sujeta a cambios, con fines de mejorar el producto, sin previo aviso a los usuarios.

Antes de usar la aplicación LG ThinQ

- 1 Compruebe la distancia entre el aparato y el enrutador inalámbrico (red de Wi-Fi).
 - Si la distancia entre el electrodoméstico y el enrutador inalámbrico es muy grande, la señal será débil. Puede que le tome más tiempo registrarse o que falle la instalación.
- 2 Desactive los **Datos Móviles** o **Datos Celulares** en su teléfono inteligente.

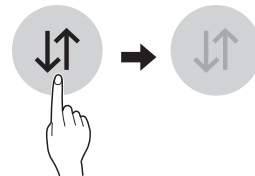

- 3 Conecte su teléfono inteligente al enrutador inalámbrico.

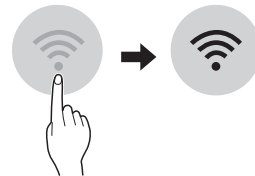

NOTA

- Para verificar la conexión Wi-Fi, revise que el ícono en el panel de control esté encendido.
- El electrodoméstico funciona únicamente con redes Wi-Fi de 2.4 GHz. Contacte a su proveedor de servicios de internet o verifique el manual del enrutador inalámbrico para revisar la frecuencia de su red.
- **LG ThinQ** no es responsable por ningún problema de conexión en red, falla, mal funcionamiento o error causado por la conexión de red.
- Si el aparato tiene problemas para conectarse a la red Wi-Fi, es posible que se encuentre demasiado lejos del router. Adquiera un repetidor Wi-Fi (extensor de alcance) para mejorar la intensidad de la señal Wi-Fi.
- Es posible que la conexión Wi-Fi no se conecte o se interrumpa debido al entorno de la red doméstica.
- Es posible que la conexión de red no funcione bien por cuestiones relacionadas con su proveedor de servicios de Internet.

NOTA

- El entorno inalámbrico circundante puede hacer que el servicio de red inalámbrica funcione lentamente.
- Si el electrodoméstico no puede registrarse debido a problemas con la transmisión de la señal inalámbrica, desconéctelo y espere alrededor de un minuto previo a intentarlo de nuevo.
- Si el cortafuegos de su enrutador inalámbrico está activado, desactívelo o añada una excepción a éste.
- El nombre de la red inalámbrica (SSID) debe ser una combinación de letras y números. (No utilice símbolos especiales)
- La interfaz de usuario (IU) del teléfono inteligente puede variar dependiendo del sistema operativo (OS) del móvil y del fabricante.
- Puede que la configuración de red falle si el protocolo de seguridad del router está en **WEP**. Cambie el protocolo de seguridad por otro (es recomendado el **WPA2**) y registre el producto de nuevo.

Instalación de la aplicación LG ThinQ

Busque la aplicación **LG ThinQ** en la tienda Google Play o App Store desde su teléfono inteligente. Siga las instrucciones para descargar e instalar la aplicación.

Uso remoto del electrodoméstico

Remote Start (Inicio remoto)

Utilice un teléfono inteligente para controlar su electrodoméstico de manera remota. También puede monitorear el funcionamiento del ciclo para saber cuánto tiempo le queda.

Uso de Remote Start (Inicio remoto)

- 1 Coloque la ropa para lavar dentro del tambor y añada detergente a la bandeja dispensadora de detergente.
 - Si así lo desea, añada blanqueador o suavizante en las áreas apropiadas del dispensador.
- 2 Presione el botón de **Encendido/Apagado**.

- 3 Mantenga presionado el botón **Remote Start (Inicio remoto)** durante 3 segundos para habilitar la función de control remoto.
- 4 Inicie un ciclo desde la aplicación **LG ThinQ** en su teléfono inteligente.

NOTA

- Una vez que esté habilitada esta función, usted puede empezar un ciclo desde la aplicación **LG ThinQ** para teléfonos inteligentes. Si el ciclo no inició, el electrodoméstico esperará a que el ciclo se inicie hasta que este se apague de forma remota desde la aplicación, o al deshabilitar esta función.
- Si se abrió la puerta, no puede iniciar un ciclo remoto.

Deshabilite Remote Start (Inicio remoto) de forma manual

Cuando la función esté activada, mantenga presionado el botón **Remote Start (Inicio remoto)** por 3 segundos.

Download Cycle (Descarga de ciclo)

Usted puede descargar ciclos nuevos y especializados que no se encuentran incluidos en los ciclos estándar del electrodoméstico.

Los artefactos que se han conectado correctamente tienen la posibilidad de descargar una variedad de ciclos especiales específicos para ellos.

Una vez que se completa la descarga de un ciclo en el artefacto, el producto mantiene el ciclo descargado hasta que se descarga un nuevo ciclo.

NOTA

- Solo se puede guardar un ciclo descargado a la vez en el electrodoméstico.

Especificaciones módulo LAN inalámbrico

Modelo	LCW-004 o LCW-007
Rango de frecuencia	2412 - 2462 MHz
Potencia de salida (máx.)	< 30 dBm

Aviso de la FCC

El siguiente aviso abarca el módulo del transmisor que contiene este producto.

Este equipo fue probado y se determinó que cumple con los límites para los dispositivos digitales de Clase B, en conformidad con la parte 15 de las normas de la FCC. Estos límites están diseñados para ofrecer una protección razonable contra interferencias dañinas en una instalación residencial. Este equipo genera, usa y puede emitir energía de radiofrecuencia y, si no se instala y utiliza de acuerdo con las instrucciones, podría causar interferencias dañinas a las comunicaciones por radio. Sin embargo, no se garantiza que dicha interferencia no pueda ocurrir en instalaciones particulares. Si este equipo causa interferencia dañina a la recepción de radio o televisión, que se puede determinar encendiendo y apagando el equipo, se aconseja al usuario intentar corregir la interferencia realizando alguna de las siguientes acciones:

- Reorientar o reubicar la antena receptora.
- Aumentar la separación entre el equipo y el receptor.
- Conectar el equipo a una toma de corriente en un circuito diferente del utilizado por el receptor.
- Consultar al vendedor o a un técnico de radio/TV con experiencia para solicitar ayuda.

El dispositivo cumple con la parte 15 de las Reglas FCC. La operación está sujeta a las siguientes dos condiciones:

- (1) Este dispositivo no debe causar interferencia dañina, y
- (2) Este dispositivo debe aceptar cualquier interferencia recibida, incluso aquellas que pudieran causar un funcionamiento no deseado del dispositivo.

Cualquier cambio o modificación en la construcción de este dispositivo, que no cuente con la aprobación expresa de la parte responsable del cumplimiento, puede anular la autorización del usuario para operarlo.

Declaración sobre exposición a la radiación de RF de la FCC

Este equipo cumple con los límites de exposición a la radiación de la FCC establecidos para entornos no controlados. Este transmisor no se debe ubicar ni operar junto con ninguna otra antena ni transmisor.

El equipo se debe instalar y operar con una distancia mínima de 20 cm (7.8 pulg.) entre la antena y su cuerpo. Los usuarios deben seguir las

instrucciones de operación específicas de manera tal de cumplir con las normas de exposición a la RF.

Declaración de Industry Canada

Este dispositivo contiene transmisores/receptores exentos de licencia que cumplen con las RSS de innovación, ciencia y desarrollo económico exentas de licencia de Canadá. Su funcionamiento queda sujeto a las siguientes condiciones:

- (1) Este dispositivo no debe causar interferencia.
- (2) Este dispositivo debe aceptar cualquier interferencia recibida, incluyendo interferencia que puede causar el funcionamiento no deseado del dispositivo.

Declaración sobre Exposición a Radiación de la IC

Este equipo cumple con los límites de exposición a la radiación de la IC establecidos para entornos no controlados.

Este equipo debe ser instalado y operado con una distancia mínima de 20 cm (7.8 pulg.) entre la antena y su cuerpo.

NOTA



- EL FABRICANTE NO SE HACE RESPONSABLE DE CUALQUIER INTERFERENCIA DE TV O RADIO CAUSADA POR MODIFICACIONES NO AUTORIZADAS A ESTE EQUIPO. TALES MODIFICACIONES PODRÍAN ANULAR LA AUTORIDAD DEL USUARIO PARA PONER EL EQUIPO EN FUNCIONAMIENTO.

Software de código abierto

Para obtener el código fuente bajo GPL, LGPL, MPL y otras licencias de código abierto que contiene este producto, visite <http://opensource.lge.com>. Además del código fuente, se pueden descargar los términos de la licencia, las anulaciones de la garantía y los avisos de derechos de autor.

LG Electronics también le proporcionará el código abierto en un CD-ROM por un costo que cubra los gastos de dicha distribución (como el costo del medio, del envío y de la manipulación) una vez realizado el pedido por correo electrónico a la dirección opensource@lge.com. Esta oferta es válida solo durante un período de tres años después de que se envíe el último cargamento de este producto. Esta oferta es válida para todo aquel que reciba esta información.

Función Smart Diagnosis™ (Diagnóstico Inteligente)

Esta característica solo está disponible en el modelo con el logo  o .

Utilice esta función como ayuda para diagnosticar y resolver problemas con su electrodoméstico.

NOTA

- Por motivos no atribuibles a la negligencia de LG, es posible que el servicio no pueda funcionar debido a factores externos como por ejemplo, la indisponibilidad de Wi-Fi, desconexión de Wi-Fi, política de la tienda de aplicaciones local o indisponibilidad de aplicaciones, entre otros.
- Esta función puede estar sujeta a cambios sin previo aviso y puede tener una forma diferente según dónde se encuentre ubicado.

Uso de LG ThinQ para diagnosticar problemas



Si experimenta un problema con su electrodoméstico equipado con Wi-Fi, este puede transmitir datos sobre la resolución de problemas a un teléfono inteligente con la aplicación **LG ThinQ**.

- Inicie la aplicación **LG ThinQ** y seleccione la función **Smart Diagnosis™** en el menú. Siga las instrucciones provistas en la aplicación **LG ThinQ**.

Uso del diagnóstico audible para diagnosticar problemas

Siga las instrucciones a continuación para utilizar el método de diagnóstico audible.

- Inicie la aplicación **LG ThinQ** y seleccione la función **Smart Diagnosis™** en el menú. Siga las instrucciones para el diagnóstico audible provistas en la aplicación **LG ThinQ**.

- 1** Presione el botón **Encendido/Apagado** para encender el electrodoméstico.
 - No presione ningún otro botón.
- 2** Coloque el micrófono de su teléfono inteligente cerca del logo  o .

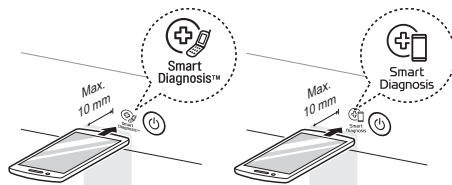

- 3** Mantenga presionado el botón **Temp. (Temperatura)** por **3 segundos** o hasta que comiencen los tonos audibles. Sostenga el micrófono del teléfono inteligente en el logo hasta que se complete la transferencia de datos.
 - Mantenga el teléfono inteligente en su lugar hasta que finalice la transferencia de datos. Se mostrará el tiempo restante para la transferencia de datos.
- 4** Después de que se complete la transferencia de datos, el diagnóstico se mostrará en la aplicación.

NOTA

- Para obtener resultados óptimos, no mueva el teléfono inteligente mientras se transmitan los tonos.

MANTENIMIENTO

⚠ ADVERTENCIA

- Para reducir el riesgo de incendios, descargas eléctricas o lesiones, lea todo el manual del usuario, incluidas las **INSTRUCCIONES DE SEGURIDAD**, antes de utilizar este aparato.
- Desconecte el aparato antes de limpiarlo para evitar el riesgo de descargas eléctricas. El incumplimiento de esta advertencia puede causar lesiones graves, incendios, descargas eléctricas o incluso la muerte.
- No utilice sustancias volátiles (benceno, disolvente, alcohol, acetona, etc.), limpiadores abrasivos o detergentes con componentes químicos fuertes al limpiar la lavadora, ya que se puede decolorar o dañar el aparato, o provocarse un incendio.
- Ciertas piezas internas no tienen conexión a tierra en forma intencional y pueden presentar un riesgo de descarga eléctrica sólo durante la reparación. Personal de servicio: No toque la bomba, la válvula, el motor o el tablero de control cuando el aparato esté recibiendo energía.

Limpieza regular

Cuidado después del lavado

Luego de que finaliza un ciclo de lavado, limpie la puerta y el lado interno del sello de la puerta con un paño seco para eliminar cualquier resto de humedad.

- Seque el cuerpo de la lavadora con un paño seco para eliminar cualquier resto de humedad.
- Deje la puerta abierta para que se seque el interior del tambor.

⚠ ADVERTENCIA

- Asegúrese de que ni los niños ni las mascotas ingresen al tambor. Active la función **Control Lock (Bloqueo de Panel)**, si fuera necesario, para evitar que los niños inicien un ciclo de lavado accidentalmente.

Limpieza del exterior

El cuidado adecuado de su lavadora puede prolongar su vida.

Puerta:

Límpiala por fuera y por dentro con un paño húmedo y luego séquela con un paño suave.

Exterior:

- Seque inmediatamente cualquier derrame.
- Límpielo con un paño húmedo.
- No toque la superficie o la pantalla con objetos punzantes o filosos.

Mantenimiento periódico

- Use una toalla o un paño suave para limpiar alrededor de la abertura de la puerta y el vidrio de la puerta de la lavadora.
- Siempre retire las prendas de la lavadora tan pronto como termine el ciclo. Si deja las prendas húmedas en la lavadora, estas pueden arrugarse, transferir color y provocar olores.

Limpiando el Tambor

Puede que con el tiempo se acumulen residuos en el tambor, provocando cierto olor a moho. Ejecute el ciclo **Tub Clean (Limpiando el Tambor)** **mensualmente** para remover residuos y prevenir la formación de olores.

NOTA

- Asegúrese de ejecutar el ciclo de **Tub Clean (Limpiando el Tambor)** solo cuando el tambor se encuentre vacío. Nunca coloque ropa para lavado mientras utilice este ciclo. La ropa puede dañarse o contaminarse con los productos de limpieza.
- Ejecútelo más seguido bajo condiciones intensas de uso, o si ya ha detectado el mal olor.
- Si ya percibe olor a humedad o a moho, ejecute este ciclo semanalmente durante tres semanas consecutivas.

- 1 Quite todas las prendas del tambor.

2 Coloque los productos de limpieza.

Producto de limpieza	Instrucciones
Limpiador de tambor	Añádalo al compartimiento principal de detergente en el dispensador.
Removedor de cal	
Blanqueador con cloro líquido	Añádalo al compartimiento de blanqueador del dispensador.
Limpiador en polvo	Extraiga el recipiente de detergente líquido antes de agregar el limpiador en el compartimiento de detergente para lavado principal.
Tabletas de limpieza	Colóquelas directamente en el tambor de la lavadora.

- Para otros productos de limpieza, siga las instrucciones y recomendaciones del fabricante del producto.
- No sobrepase la línea de llenado máximo cuando añada blanqueador o limpiadores en polvo. Los limpiadores en polvo podrían quedar en el tambor luego de la limpieza.

3 Cierre la puerta y presione el botón de **Encendido/Apagado**.

4 Seleccione el ciclo **Tub Clean (Limpiando el Tambor)** y luego presione el botón de **Inicio/Pausa** para iniciar el ciclo.

5 Luego de que finalice el ciclo, abra la puerta y permita que se seque completamente el interior del tambor.

ADVERTENCIA

- Asegúrese de que ni los niños ni las mascotas ingresen al tambor. Active la función **Control Lock (Bloqueo de Panel)**, si fuera necesario, para evitar que los niños inicien un ciclo de lavado accidentalmente.

NOTA

- Si utiliza un desincrustador o un limpiador de tambor durante el ciclo **Tub Clean (Limpiando el Tambor)**, use la opción **Rinse+Spin (Enjuague+Centrifugado)** para enjuagar el

tambor de la lavadora antes de realizar el siguiente ciclo de lavado.

Alerta automática para limpieza de la cuba

Cuando la lavadora se encuentra encendida y el mensaje **EtL** parpadea en la pantalla, significa que el tambor debe limpiarse. Utilice el ciclo **Tub Clean (Limpiando el Tambor)** para limpiar el tambor de la lavadora. La frecuencia de la aparición de la alerta automática dependerá de cuán a menudo se utilice la lavadora. No obstante, el mensaje por lo general aparecerá cada uno o dos meses.

Remoción de acumulación de minerales

En áreas con aguas duras, se pueden formar sedimentos minerales en los componentes internos de la lavadora. Limpie periódicamente la acumulación de minerales en los componentes internos para prolongar la vida útil de la lavadora. Se recomienda utilizar un ablandador de agua en áreas con aguas duras.

- Utilice un descalcificador para eliminar la acumulación visible de minerales en el tambor de la lavadora.
- Luego de limpiar con el descalcificador, siempre ejecute el ciclo de **Tub Clean (Limpiando el Tambor)** antes de lavar ropa.
- Los sedimentos minerales y otras manchas pueden eliminarse del tambor de acero inoxidable utilizando un paño suave embebido en un limpiador para acero inoxidable.
- No use lana de acero ni limpiadores abrasivos.

Dejar la puerta abierta

Después de terminar de usar la lavadora, deje la puerta abierta durante la noche para permitir que el aire circule y seque el tambor. Esto ayuda a prevenir olores.

Limpiando la Bandeja del Dispensador

Dejar detergente en el dispensador por un largo periodo de tiempo o utilizar la lavadora por un largo periodo de tiempo podría causar la acumulación de residuos en el dispensador de detergente. Saque y limpie el dispensador de detergente **una o dos veces por mes**.

⚠ ADVERTENCIA

- No rocíe agua dentro de la lavadora. Hacerlo podría causar un incendio o una descarga eléctrica.

- 1 Apague la lavadora y desenchufe el cable de alimentación.
- 2 Extraiga la bandeja hasta que se detenga.
- 3 Presione hacia abajo el botón de desenganche ① y tire de la bandeja completamente hacia afuera.

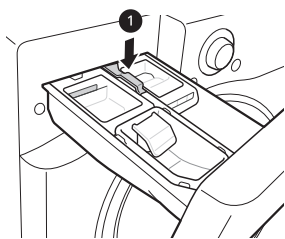

- 4 Remueva los insertos de la bandeja.
- 5 Limpie los insertos y la bandeja con agua tibia.
 - Utilice un paño suave o un cepillo para limpiar y remover cualquier residuo.
 - No utilice jabón al limpiar la bandeja y los insertos.
- 6 Seque la humedad con un paño o una toalla seca luego de limpiar.
- 7 Para limpiar la apertura de la bandeja, utilice un pequeño cepillo no metálico. Remueva todo el residuo de las parte superior e inferior del hueco.
- 8 Reemplace la bandeja.

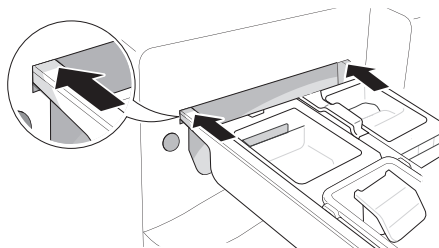
**Limpieza del sello de la puerta**

Limpie el sello de la puerta **una vez por mes** para prevenir la acumulación de suciedad.

⚠ PRECAUCIÓN

- Limpiar el sello de la puerta con blanqueador sin diluir puede causar mal funcionamiento del sello de la puerta y de las piezas de la lavadora. Debe agregarle agua al blanqueador antes de limpiar el sello.

- 1 Utilice guantes de caucho y gafas protectoras.
- 2 Diluya 3/4 taza (177 mL) de blanqueador con cloro líquido en 1 galón (3.8 L) de agua.
- 3 Limpie toda la circunferencia del sello.
 - Empape una esponja o un paño suave en esta solución de cloro diluido y limpie alrededor del sello de la puerta.
- 4 Seque la humedad con un paño o una toalla seca luego de limpiar.
- 5 Deje la puerta abierta para permitir que el sello de la puerta se seque completamente.

Limpieza de los filtros de entrada de agua

Si la lavadora no se llena correctamente, aparecerá un mensaje de error en la pantalla. Las rejillas del filtro de la válvula de entrada de agua pueden taparse por el sarro que se forma en las aguas duras, sedimentos en el suministro de agua u otros desechos.

⚠ ADVERTENCIA

- Las rejillas de entrada protegen las partes delicadas de la válvula de partículas que puedan ingresar a través del suministro de agua. Operar la lavadora sin estos filtros podría causar que una válvula se quede abierta continuamente, provocando una inundación y/o daños a la propiedad.

⚠ PRECAUCIÓN

- No use la lavadora sin los filtros de entrada. Hacerlo causará fugas y mal funcionamiento.

⚠ PRECAUCIÓN

- Si usa la lavadora en un área de aguas duras, el filtro de entrada puede obstruirse por la acumulación de cal y requeriría una limpieza más frecuente.

- 1 Apague la lavadora y desenchufe el cable de alimentación.
- 2 Cierre las llaves de paso de agua caliente y fría.
- 3 Desenrosque las mangueras de agua caliente y fría de la parte posterior de la lavadora.
- 4 Retire los filtros de las válvulas de agua cuidadosamente.
 - Use pinzas para retirar los filtros de las válvulas de agua.

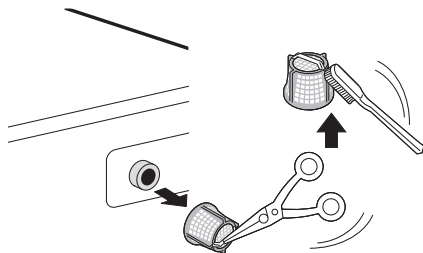

- 5 Retire objetos extraños y sumerja los filtros en vinagre blanco o en un removedor de cal.
 - Si utiliza un removedor de cal, siga las instrucciones del fabricante. Tenga cuidado de no dañar los filtros mientras los limpia.
- 6 Enjuague bien los filtros y vuelva a colocarlos en su sitio.
- 7 Enjuague las mangueras del agua y vuelva a fijarlas en su lugar.
 - Antes de volver a colocar las mangueras de entrada de agua, enjuáguelas haciendo correr bastante agua por ellas hacia una cubeta o desagüe. Preferentemente, hágalo con las llaves de paso del agua abiertas por completo, para que fluya el máximo posible de agua.

NOTA

- Un mensaje de error i E puede aparecer parpadeando en la pantalla si la presión del agua es demasiado débil o si el filtro se encuentra obstruido por suciedad. Limpie el filtro de entrada.

Limpieza del filtro de la bomba de desagüe

La lavadora no podrá desagotar el agua del lavado si el filtro de la bomba de desagüe está obstruido. Limpie el filtro de desagüe periódicamente para evitar que se obstruya con objetos extraños.

⚠ ADVERTENCIA

- Si abre el filtro de desagüe provocará que brote agua, en caso de que haya agua en el tambor. Sírvese de una cubeta si el tambor no está completamente desagotado antes de abrir el filtro de desagüe.
- Utilizar la lavadora sin el filtro de desagüe o con un filtro de desagüe montado de manera incorrecta puede provocar fugas o mal funcionamiento de la lavadora.

- 1 Apague la lavadora y desenchufe el cable de alimentación.
- 2 Abra la cubierta del filtro de la bomba de desagüe.

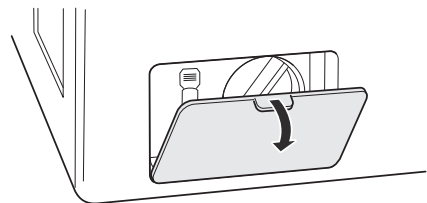

- 3 Desagote el agua restante si la hubiera.
 - Desenganche la manguera de desagüe y quite el tapón para desagotar el agua restante.

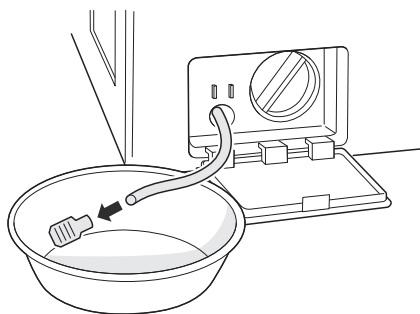

4 Retire el filtro de la bomba.

- Desenrosque el filtro de la bomba hacia la izquierda para quitarlo.

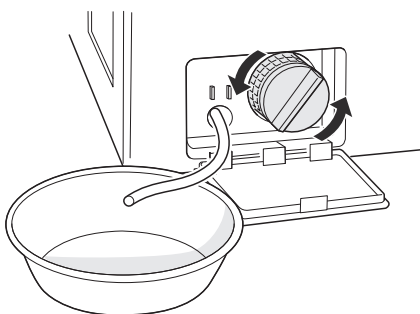

5 Limpie el filtro de la bomba y la abertura.

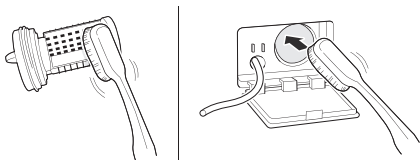

6 Vuelva a montar el tapón en la manguera de desagüe y vuelva a sujetar la manguera de desagüe.

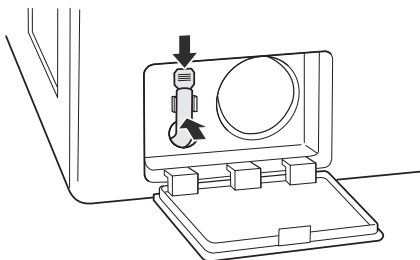

7 Inserte el filtro de la bomba de desagüe.

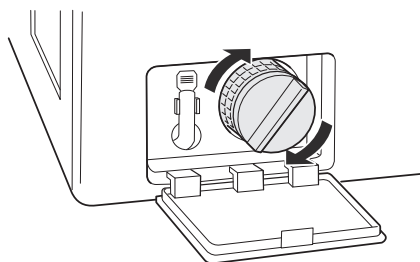

8 Cierre la cubierta del filtro de la bomba de desagüe.

NOTA

- El mensaje **E** aparece parpadeando en la pantalla cuando el filtro de la bomba de desagüe está obstruido con suciedad. Limpie el filtro de la bomba de desagüe.

Cuidado en climas fríos

Almacenamiento de la lavadora

Si la lavadora no va a ser utilizada por un período prolongado y se encuentra en una zona en la que puede quedar expuesta a temperaturas bajo cero, siga estos pasos para protegerla de daños.

NOTA

- Asegúrese de que el tambor esté vacío antes de seguir estos pasos.

- 1 Apague la lavadora y desenchufe el cable de alimentación.
- 2 Cierre las llaves de paso de agua.
- 3 Desconecte las mangueras del suministro de agua. Drene el agua que quede en ellas.

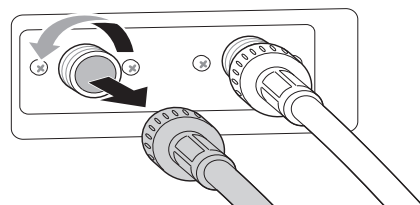

42 MANTENIMIENTO

- 4** Enchufe el cable de alimentación en un tomacorriente correctamente conectado a tierra.
- 5** Agregue 1 galón de anticongelante no tóxico para vehículos recreativos (RV) en el tambor vacío y cierre la puerta.
 - Nunca use anticongelante para automóviles.
- 6** Apague la lavadora y presione el botón de **Spin (Centrifugado)**.
- 7** Presione el botón de **Inicio/Pausa** para dar arranque a la bomba de desagüe para **1 minutos**.
 - Esto expulsará una cantidad de anticongelante y dejará solo el necesario para proteger la lavadora de posibles daños.
- 8** Apague la lavadora y desenchufe el cable de alimentación.
- 9** Seque el interior del tambor con un paño suave y cierre la puerta.
- 10** Guarde la lavadora en posición vertical.
- 11** Quite los insertos del dispensador. Desagote el agua que pueda haber en los compartimientos y déjelos secar.
- 12** Para quitar el anticongelante de la lavadora luego de haberla tenido guardada, ejecute el ciclo **Rinse+Spin (Enjuague+Centrifugado)** usando detergente.
 - No coloque ropa para lavar en este ciclo.

Cuando las mangueras de entrada de agua están congeladas

- 1** Apague la lavadora y desenchufe el cable de alimentación.
- 2** Cierre las llaves conectadas a las mangueras de entrada de agua.

- 3** Vierta agua caliente sobre las llaves congeladas para descongelar las mangueras de entrada de agua y poder retirarlas.
- 4** Sumerja las mangueras de entrada de agua en agua caliente para descongelarlas.
- 5** Vuelva a conectar las mangueras de entrada a las entradas de agua de la lavadora y a las llaves.
 - Consulte la sección **Conexión de las mangueras de entrada de agua** para obtener más detalles.
- 6** Abra las llaves de paso.
- 7** Presione el botón de **Encendido/Apagado** para encender la lavadora.
- 8** Presione el botón de **Spin (Centrifugado)** para hacer funcionar solo el ciclo de centrifugado para desagote y centrifugado.
- 9** Presione el botón de **Inicio/Pausa**.

Cuando se congela la manguera de desagüe

- 1** Vierta agua caliente en el tambor de la lavadora y cierre la puerta.
- 2** Espere durante **1 o 2 horas**.
- 3** Presione el botón de **Encendido/Apagado**.
- 4** Presione el botón de **Spin (Centrifugado)** para hacer funcionar solo el ciclo de centrifugado para desagote y centrifugado.
- 5** Presione el botón de **Inicio/Pausa** para verificar que el agua se drene correctamente.

SOLUCIÓN DE PROBLEMAS

Antes de llamar al servicio técnico

La lavadora está equipada con un sistema automático de detección de errores para detectar y diagnosticar problemas en una etapa temprana. Si la lavadora no funciona correctamente o no funciona en absoluto, compruebe lo siguiente antes de llamar al servicio técnico.

Preguntas frecuentes

P: ¿Por qué mi lavadora hace ruidos fuertes similares a golpes cuando se está llenando con agua?

R: En realidad, se trata de un problema de fontanería de su hogar. Cuando la válvula de agua de la lavadora se cierra, puede causar que las tuberías de su hogar se muevan, lo que provoca un fuerte ruido de golpes. Este efecto, llamado golpe de ariete, puede reducirse si se instala un artículo denominado supresor de golpes de ariete. Puede obtener estos complementos supresores en su ferretería local o en una tienda de materiales de construcción.

P: ¿Por qué hay tan poca agua en mi lavadora? ¿Cómo puede limpiar la ropa?

R: Las lavadoras HE (de alta eficiencia) están diseñadas para lavar adecuadamente su ropa utilizando una cantidad mínima de agua y energía. Debido a que el volumen de agua es bajo, la escasa cantidad de detergente utilizado se encuentra más concentrado en el agua, lo que tiene como resultado un lavado de rendimiento excelente.

P: Cuando presiono un botón, ¿por qué la lavadora emite un pitido y luego no sucede nada?

R: La función **Control Lock (Bloqueo de Panel)** está activa. Para apagarla, encienda la lavadora y luego mantenga presionado el botón que tenga la indicación **Control Lock (Bloqueo de Panel)** sobre o debajo de él durante **3 segundos**.

P: ¿Dónde debo verter detergente de lavandería en polvo cuando lavo la ropa?

R: Si usa detergente de lavandería en polvo, colóquelo en el compartimiento del detergente principal luego de retirar el accesorio para detergente líquido. Los agentes de limpieza para lavandería o un blanqueador protector de color en polvo deben colocarse directamente en el tambor. Estos productos se pueden colocar en el tambor vacío antes de cargar la ropa o sobre la ropa luego de cargar la lavadora.

Mensajes de error

Problemas	Causas posibles y solución
IE ERROR DE ENTRADA	<p>Las llaves de paso del suministro de agua no están abiertas por completo.</p> <ul style="list-style-type: none"> Asegúrese de que las llaves de paso del agua estén completamente abiertas. <p>Las mangueras de entrada de agua se encuentran retorcidas, pellizcadas o aplastadas.</p> <ul style="list-style-type: none"> Asegúrese de que las mangueras no estén retorcidas, pellizcadas ni aplastadas detrás o debajo de la lavadora. Tenga cuidado cuando mueva la lavadora para su limpieza o mantenimiento. <p>Los filtros de entrada de agua están obstruidos.</p> <ul style="list-style-type: none"> Limpe los filtros de entrada. Consulte MANTENIMIENTO. <p>La presión del suministro de agua de la casa o a la llave de paso de agua es demasiado baja.</p> <ul style="list-style-type: none"> Compruebe otro grifo de la casa para asegurarse de que la presión del suministro de agua doméstico es la adecuada y que la circulación de agua no está restringida. Desconecte las mangueras de entrada de agua y haga circular algunos galones de agua por las mangueras para enjuagar el polvo que pudiera haber. Si circula demasiado lento, llame a un fontanero para que repare las tuberías de agua. <p>Suministro de agua conectado con mangueras limitadoras de fugas.</p> <ul style="list-style-type: none"> No se recomienda el uso de mangueras limita fugas. Puede que las mangueras diseñadas para limitar fugas se activen falsamente y prevengan el llenado apropiado de la lavadora.
UE ERROR DE DESEQUILIBRIO	<p>La carga es muy pequeña.</p> <ul style="list-style-type: none"> Agregue prendas adicionales para que la lavadora logre equilibrar la carga. <p>Hay artículos pesados mezclados con otros más livianos.</p> <ul style="list-style-type: none"> Siempre trate de lavar artículos de peso más o menos similar para que la lavadora pueda distribuir de forma pareja el peso de la carga para el centrifugado. <p>La carga está desequilibrada.</p> <ul style="list-style-type: none"> Redistribuya la carga manualmente si los artículos se han enredado y están previniendo que el equilibrado automático funcione apropiadamente.
dE, dE 1, dE2, dE4 ERROR DE LA PUERTA ABIERTA	<p>La puerta no está asegurada.</p> <ul style="list-style-type: none"> Cierre y asegure la puerta. Si el mensaje sigue apareciendo, desenchufe el cable de alimentación y llame al servicio técnico.
QE ERROR DE LA SALIDA DE AGUA	<p>La manguera de desagüe está retorcida, pellizcada u obstruida.</p> <ul style="list-style-type: none"> Asegúrese que la manguera de drenaje esté libre de atascos o torceduras, y que no esté apretada detrás o debajo de la lavadora. <p>El extremo de la manguera de drenaje está a más de 96 pulgadas (2.4 m) en relación al fondo de la lavadora.</p> <ul style="list-style-type: none"> Mueva el extremo de la manguera de drenaje para que esté a menos de 96 pulgadas (2.4 m).
EE ERROR EN EL SENSOR DE TEMPERATURA	<p>Error de control.</p> <ul style="list-style-type: none"> Desenchufe la lavadora y espere 60 minutos. Vuelva a conectarla a la electricidad e intente de nuevo. Si se sigue mostrando el código de error, llame al servicio técnico
FE ERROR DE DESBORDE	<p>El nivel del agua es demasiado alto debido a una válvula de agua defectuosa.</p> <ul style="list-style-type: none"> Cierre las llaves de paso del agua, desenchufe la lavadora y llame al servicio técnico.
PE ERROR EN EL SENSOR DE PRESIÓN	<p>El sensor del nivel de agua no funciona correctamente.</p> <ul style="list-style-type: none"> Cierre las llaves de paso del agua, desenchufe la lavadora y llame al servicio técnico.

Problemas	Causas posibles y solución
LE ERROR DE MOTOR BLOQUEADO	Ha ocurrido un error del motor. <ul style="list-style-type: none"> • Deje la lavadora apagada durante 30 minutos y luego reinicie el ciclo. • Si se sigue mostrando el código de error, llame al servicio técnico.
5ud DETECCIÓN DE EXCESO DE ESPUMA	Exceso de espuma del detergente <ul style="list-style-type: none"> • No agregue más detergente que la cantidad recomendada por el fabricante. • Para retirar el exceso de espuma, apague la lavadora y vuelva a encenderla; luego ejecute el ciclo de Rinse+Spin (Enjuague+Centrifugado). • Si se detecta demasiada espuma durante el centrifugado, la lavadora se detiene para evitar que se produzcan fugas.
PF ERROR EN EL SENSOR DE NIVEL DE AGUA	El nivel de agua es muy bajo o muy alto comparado con la carga. <ul style="list-style-type: none"> • Desenchufe la lavadora y espere unos 60 minutos. Vuelva a conectarla a la electricidad e intente de nuevo. • Si se sigue mostrando el código de error, llame al servicio técnico.
FF ERROR DE CONGELAMIENTO	La manguera de entrada, la manguera de drenaje o la bomba de drenaje está congelada. <ul style="list-style-type: none"> • Vea la sección Cuidado en climas fríos.
CL FUNCIÓN DE BLOQUEO INFANTIL	La función de Control Lock (Bloqueo de Panel) está activada para evitar que cualquier persona cambie los ciclos o haga funcionar la lavadora. <ul style="list-style-type: none"> • Desactive la función de Control Lock (Bloqueo de Panel) en el panel de control. Vea Control Lock (Bloqueo de Panel) en Opciones y funciones adicionales.
EcL ALARMA DE LIMPIEZA DE CUBA	Es tiempo de ejecutar el ciclo de Tub Clean (Limpiando el Tambor). <ul style="list-style-type: none"> • Este no es un código de error. Este código indica que el ciclo Tub Clean (Limpiando el Tambor) se está ejecutando o que es necesario hacerlo para limpiar el tambor de la lavadora.
u5 ERROR DEL SENSOR DE VIBRACIÓN	Mal funcionamiento del sensor de vibración. <ul style="list-style-type: none"> • Llame al servicio técnico.

Ruidos

Problemas	Causas posibles y solución
Haciendo clic	Las trabas de la puerta suenan cuando la puerta se bloquea o desbloquea. <ul style="list-style-type: none"> • Funcionamiento normal
Rociado o silbido	Agua que circula o se rocía durante el ciclo <ul style="list-style-type: none"> • Funcionamiento normal
Zumbido o gorgoteo	La bomba de desagüe bombea agua desde la lavadora en ocasiones durante un ciclo. <ul style="list-style-type: none"> • Funcionamiento normal
Chapoteo de agua	Un líquido en el anillo de equilibrio alrededor del pulsador ayuda a que el cesto gire suavemente. <ul style="list-style-type: none"> • Funcionamiento normal

Problemas	Causas posibles y solución
Agua entrando a la lavadora después de que esta ya comenzó a funcionar.	La lavadora adapta el lavado al tipo y al tamaño de la carga y agrega más agua al ciclo cuando resulta necesario. <ul style="list-style-type: none"> • Funcionamiento normal
	La carga de ropa puede estar desequilibrada. Si la lavadora percibe que la carga está desequilibrada, se detiene y vuelve a llenarse para redistribuirla. <ul style="list-style-type: none"> • Funcionamiento normal
	La lavadora podría estar diluyendo los productos de lavandería para agregarlos al lavado. <ul style="list-style-type: none"> • Funcionamiento normal
Ruido metálico y de traqueteo	Puede haber objetos extraños, como por ejemplo llaves, monedas o alfileres de gancho en el tambor o la bomba. <ul style="list-style-type: none"> • Detenga la lavadora, verifique el tambor y el filtro de desagüe para detectar objetos extraños. • Si el ruido continúa después de reiniciar la lavadora, llame al servicio técnico.
Golpeteo	Las cargas pesadas pueden producir un golpeteo. <ul style="list-style-type: none"> • Esto es normal, pero, si el sonido continúa, probablemente la lavadora se encuentra desequilibrada. Detenga la lavadora y distribuya la carga nuevamente.
	La carga puede estar desequilibrada. <ul style="list-style-type: none"> • Pause el ciclo y distribuya la carga después de que se desbloquee la puerta.
Ruido de Vibración	No se quitaron todos los materiales de empaque. <ul style="list-style-type: none"> • Consulte Desempacando y removiendo el material de transporte en INSTALACIÓN.
	La carga de lavado se encuentra distribuida de manera despareja en el tambor. <ul style="list-style-type: none"> • Pause el ciclo y distribuya la carga después de que se desbloquee la puerta.
	No todas las patas de nivelación están bien afirmadas al suelo y adecuadamente niveladas. <ul style="list-style-type: none"> • Consulte Nivelación de la lavadora en INSTALACIÓN.
	El suelo no es lo suficientemente rígido. <ul style="list-style-type: none"> • Asegúrese de que el piso es sólido y no se flexiona. Vea Piso en INSTALACIÓN.
Ruido de chirridos	No se quitaron todos los materiales de empaque. <ul style="list-style-type: none"> • Consulte Desempacando y removiendo el material de transporte en INSTALACIÓN.
Ruido de golpes cuando la lavadora se está llenando con agua. (Golpe de ariete)	La fontanería en el hogar se mueve o flexiona cuando las válvulas de la lavadora se cierran. <ul style="list-style-type: none"> • El golpe de ariete no es provocado por un defecto de la lavadora. Instale supresores de golpes de ariete (se compran aparte, en su ferretería local o en una tienda de materiales de construcción) entre la manguera de llenado y la lavadora para obtener resultados óptimos.
	La presión del suministro de agua doméstico es muy alta. <ul style="list-style-type: none"> • Ajuste el regulador del suministro de agua doméstico a una presión menor o llame a un fontanero.

FUNCIONAMIENTO

Problemas	Causas posibles y solución
Fuga de agua	<p>Las mangueras no están conectadas correctamente.</p> <ul style="list-style-type: none"> • Verifique la presencia de fugas, rajaduras o quebraduras en las mangueras y los conectores. • Compruebe y apriete las conexiones de las mangueras.
	<p>Los tubos de drenaje están obstruidos.</p> <ul style="list-style-type: none"> • La lavadora bombea agua a mucha velocidad. Verifique si el agua vuelve de la tubería de desagüe durante el desagote. Si ve que sale agua del desagüe, compruebe que la manguera de desagüe esté correctamente instalada y verifique que no existan obstrucciones en el desagüe. • Llame a un fontanero para reparar la tubería de desagüe.
	<p>La manguera de desagüe se salió del conector del desagüe o no está introducida lo suficiente.</p> <ul style="list-style-type: none"> • Amarre la manguera de desagüe a la manguera de entrada o al tubo independiente para evitar que se salga durante el desagote. • Para tuberías de desagüe más pequeñas, inserte la manguera de desagüe en la tubería hasta la brida de la manguera. Para tuberías de desagüe de mayores dimensiones, inserte la manguera de desagüe en la tubería pasando de 1 a 2 pulgadas la brida de la manguera.
	<p>Exceso de espuma del detergente</p> <ul style="list-style-type: none"> • El exceso de espuma puede generar fugas y puede estar ocasionado por el tipo y la cantidad de detergente utilizado. El único detergente recomendado es el de alta eficiencia (HE). La cantidad normal de detergente que debe utilizarse es de 1/4 a 1/2 de la cantidad máxima recomendada por el fabricante de detergente. • Siempre reduzca la cantidad de detergente si la carga es pequeña, está poco sucia, o si el agua es muy suave. • Nunca utilice más de la cantidad máxima recomendada por el fabricante del detergente.
Espuma excesiva	<p>Demasiado detergente o detergente incorrecto.</p> <ul style="list-style-type: none"> • Los detergentes HE están formulados específicamente para lavadoras de alta eficiencia y contienen agentes de reducción de espuma. Use solo detergente con el logotipo de alta eficiencia (HE). • Para conocer las cantidades de detergente, consulte Uso de detergente en FUNCIONAMIENTO. Si el exceso de espuma o el residuo de detergente siguen siendo un problema, añada un enjuague adicional.
La lavadora no enciende.	<p>El cable de alimentación no está enchufado correctamente.</p> <ul style="list-style-type: none"> • Asegúrese de que el enchufe esté conectado de manera segura en un tomacorriente de 120 V CA, 60 Hz de 3 clavijas con conexión a tierra.
	<p>Se quemó el fusible del hogar, saltó el interruptor de corriente o hay un corte de energía.</p> <ul style="list-style-type: none"> • Restablezca el interruptor de corriente o reemplace el fusible. No aumente la potencia nominal del fusible. Si el problema es una sobrecarga del circuito, llame a un electricista calificado para que lo solucione.
El ciclo de lavado es más prolongado que lo normal.	<p>La lavadora automáticamente ajusta el tiempo del lavado según la cantidad de ropa, la presión del agua y otras condiciones de funcionamiento.</p> <ul style="list-style-type: none"> • Esto es normal. La lavadora automáticamente ajusta el tiempo del ciclo a fin de lograr resultados óptimos con el ciclo seleccionado. El tiempo restante que aparece en la pantalla es solo una estimación. El tiempo real puede variar.

Problemas	Causas posibles y solución
El detergente no se dispensa o se dispensa de forma incompleta	Los compartimientos de detergente están obstruidos por haber sido llenados de forma incorrecta. <ul style="list-style-type: none"> • Asegúrese de colocar el detergente y los aditivos en los compartimientos correctos del dispensador. • Para todos los tipos de detergente, asegúrese siempre de que el cajón del dispensador esté completamente cerrado antes del inicio del ciclo.
	Se utilizó demasiado detergente. <ul style="list-style-type: none"> • Asegúrese de utilizar la cantidad de detergente sugerida de acuerdo con las recomendaciones del fabricante. Podría también diluir el detergente con agua hasta la línea de llenado máximo del compartimiento para evitar que este se obstruya. Utilice solamente detergente de alta eficiencia (HE).
	<hr/> NOTA <ul style="list-style-type: none"> • Siempre utilice la menor cantidad de detergente que sea posible. Las lavadoras de alta eficiencia necesitan muy poca cantidad de detergente para lograr óptimos resultados. Si usa mucho detergente, puede hacer que el lavado y el enjuague sean deficientes y contribuir a que se produzcan olores en la lavadora. <hr/>
	Suministro de agua insuficiente <ul style="list-style-type: none"> • Asegúrese de que tanto la llave de agua fría como la de agua caliente estén abiertas por completo.
Residuo normal <ul style="list-style-type: none"> • Es normal que quede una pequeña cantidad de detergente en el dispensador. Si este residuo se acumula, puede interferir con el ingreso normal de los detergentes a la lavadora. Consulte las instrucciones de limpieza. 	

Problemas	Causas posibles y solución
La lavadora no funciona.	El panel de control se ha apagado por estar inactivo. <ul style="list-style-type: none"> Esto es normal. Presione el botón de Encendido/Apagado para encender la lavadora.
	La lavadora está desenchufada. <ul style="list-style-type: none"> Asegúrese de que el cable de alimentación esté conectado de manera segura a un tomacorriente.
	El suministro de agua está cerrado. <ul style="list-style-type: none"> Abra por completo las llaves de agua fría y caliente.
	Los controles no están configurados correctamente. <ul style="list-style-type: none"> Asegúrese de que el ciclo haya sido configurado correctamente, cierre la puerta y presione el botón de Inicio/Pausa para iniciar el ciclo de lavado.
	La puerta se encuentra abierta. <ul style="list-style-type: none"> Cierre la puerta y asegúrese de que no haya nada atrapado debajo de la puerta que le impida cerrarse por completo.
	Saltó el interruptor de corriente/se quemó el fusible. <ul style="list-style-type: none"> Revise los disyuntores/fusibles del hogar. Reemplace los fusibles o reinicie el interruptor. La lavadora debe estar conectada a un circuito derivado exclusivo.
	Inicio/Pausa no se presionó este botón después de configurar el ciclo. <ul style="list-style-type: none"> Presione el botón de Encendido/Apagado, luego seleccione nuevamente el ciclo deseado y presione el botón de Inicio/Pausa. Si el botón Inicio/Pausa no se presiona en cierto tiempo, la lavadora se apagará. (El tiempo varía según el modelo, de 4 a 60 minutos.)
	Presión de agua extremadamente baja. <ul style="list-style-type: none"> Compruebe otro grifo de la casa para asegurarse de que la presión del suministro de agua doméstico es la adecuada.
La lavadora no se llena correctamente.	La lavadora está demasiado fría. <ul style="list-style-type: none"> Si la lavadora ha estado expuesta a temperaturas de congelación por un largo período de tiempo, permita que entre en calor antes de presionar el botón Encendido/Apagado. De lo contrario, la pantalla no se encenderá.
	El filtro está tapado. <ul style="list-style-type: none"> Asegúrese de que los filtros de entrada en las válvulas de llenado no estén obstruidos. Consulte Limpieza de los filtros de entrada de agua en MANTENIMIENTO.
	Las mangueras pueden estar retorcidas. <ul style="list-style-type: none"> Asegúrese de que las mangueras de entrada no se encuentren retorcidas ni obstruidas.
	Eficiencia en el consumo de energía <ul style="list-style-type: none"> Esta es una lavadora de Alta Eficiencia (HE). Por lo tanto, puede que la configuración del nivel de agua para ella sea diferente a la de una lavadora convencional.
	Suministro de agua insuficiente <ul style="list-style-type: none"> Asegúrese de que tanto la llave de agua fría como la de agua caliente estén abiertas por completo.
	La puerta de la lavadora se encuentra abierta. <ul style="list-style-type: none"> Cierre la puerta y asegúrese de que no haya nada atrapado debajo de la puerta que le impida cerrarse por completo.
El nivel de agua es muy bajo. <ul style="list-style-type: none"> Normalmente el agua no cubrirá las prendas. El nivel de llenado es optimizado para que los movimientos de lavado alcancen los mejores rendimientos. 	

Problemas	Causas posibles y solución
El agua en la lavadora no drena o lo hace lentamente.	La manguera de desagüe está retorcida, pellizcada u obstruida. <ul style="list-style-type: none"> Asegúrese que la manguera de drenaje esté libre de atascos o torceduras, y que no esté apretada detrás o debajo de la lavadora.
	El extremo de la manguera de drenaje está a más de 96 pulgadas (2.4 m) en relación al fondo de la lavadora. <ul style="list-style-type: none"> Mueva el extremo de la manguera de drenaje para que esté a menos de 96 pulgadas (2.4 m).
No se dispensa el blanqueador.	La cubierta del dispensador de blanqueador no está instalada correctamente (en algunos modelos). <ul style="list-style-type: none"> Asegúrese de que la cubierta del blanqueador se encuentre instalada correctamente y bien encastrada en su lugar antes de iniciar el ciclo.
	El dispensador de blanqueador está sucio u obstruido. <ul style="list-style-type: none"> Levante la cubierta del dispensador de blanqueador y limpie la reserva. Puede que pelusa y otros residuos extraños que estén acumulados dentro del dispensador prevengan el dispensado apropiado del mismo.
El blanqueador se dispensa antes de tiempo	El dispensador se ha llenado para un uso futuro. <ul style="list-style-type: none"> No puede almacenar blanqueador en el dispensador para que sea utilizado en el futuro. El blanqueador se dispensará en cada carga.
	Llenado en exceso del dispensador de blanqueador. <ul style="list-style-type: none"> Llenar en exceso el dispensador de blanqueador causará que éste se dispense inmediatamente, dañando así sus prendas o la lavadora. Siempre mida el blanqueador, pero nunca llene sobre la línea de llenado máximo en el dispensador. Media taza de blanqueador es suficiente para la mayoría de cargas. Nunca utilice más de 1 taza de blanqueador.

Desempeño

Problemas	Causas posibles y solución
Arrugas	La ropa no se retira de la lavadora pronto. <ul style="list-style-type: none"> Siempre retire las prendas de la lavadora tan pronto como termine el ciclo.
	Lavadora sobrecargada. <ul style="list-style-type: none"> La lavadora puede estar llena por completo, pero el tambor no debe llenarse totalmente con prendas. La puerta de la lavadora debe poder cerrarse con facilidad.
	Las mangueras de entrada de agua fría y caliente están invertidas. <ul style="list-style-type: none"> Un enjuague con agua caliente puede ocasionar arrugas en las prendas. Compruebe los conectores de las mangueras de entrada.

Problemas	Causas posibles y solución
Manchas	<p>El blanqueador o el suavizante se dispensan antes de tiempo.</p> <ul style="list-style-type: none"> • Llenado en exceso del compartimiento dispensador o se cerró demasiado rápido, lo que causa que el blanqueador o el suavizante se dispensen inmediatamente. Siempre mida el blanqueador, y nunca use más de 1 taza.
	<p>El blanqueador/suavizante se agregó directamente sobre la ropa en el tambor.</p> <ul style="list-style-type: none"> • Siempre use los dispensadores para asegurarse de que los productos de lavandería se dispensen en el momento adecuado del ciclo.
	<p>La ropa no se retiró de la lavadora a tiempo.</p> <ul style="list-style-type: none"> • Siempre retire las prendas de la lavadora tan pronto como sea posible en cuanto termine el ciclo.
	<p>La ropa no se retiró de la lavadora a tiempo.</p> <ul style="list-style-type: none"> • Siempre retire las prendas de la lavadora tan pronto como sea posible en cuanto termine el ciclo.
	<p>Las prendas no se clasificaron correctamente.</p> <ul style="list-style-type: none"> • Siempre lave los colores oscuros separados de los colores claros y los blancos para evitar que se produzca decoloración. • Nunca lave ropa muy sucia con ropa poco sucia.
Eliminación de manchas deficiente	<p>No se seleccionaron opciones adecuadas.</p> <ul style="list-style-type: none"> • Las manchas más difíciles y densas pueden requerir potencia de lavado adicional. Seleccione la función Heavy (Muy Sucia) para aumentar la potencia de limpieza del ciclo elegido.
	<p>Manchas que se han fijado previamente.</p> <ul style="list-style-type: none"> • Las prendas que ya han sido lavadas pueden tener manchas que se han fijado. Puede ser difícil eliminar estas manchas, que quizás requieran un lavado a mano o un tratamiento previo para quitarlas.
Olor a humedad o a moho en la lavadora	<p>Se ha usado demasiado detergente o uno del tipo incorrecto.</p> <ul style="list-style-type: none"> • Siempre utilice solo detergente de alta eficiencia (HE) de acuerdo con las instrucciones del fabricante.
	<p>El interior del tambor no se limpió correctamente.</p> <ul style="list-style-type: none"> • Ejecute el ciclo Tub Clean (Limpiando el Tambor) regularmente.

Olor.

Problemas	Causas posibles y solución
Olor.	<p>Algo de olor es causado por la goma adjunta a la lavadora.</p> <ul style="list-style-type: none"> Este olor es normal en la goma nueva y desaparecerá después de haber utilizado la máquina algunas veces.
	<p>Si la junta de goma de la puerta y la del área del sello de esta no se limpian regularmente, pueden producirse olores causados por moho o sustancias extrañas.</p> <ul style="list-style-type: none"> Asegúrese de limpiar la junta y el sello de la puerta regularmente, así como de revisar si hay artículos pequeños debajo del sello al descargar la lavadora.
	<p>Pueden producirse olores si se dejan sustancias extrañas en el filtro de la bomba de drenaje.</p> <ul style="list-style-type: none"> Asegúrese de limpiar el filtro de la bomba de drenaje regularmente.
	<p>Pueden producirse olores si la manguera de drenaje no está correctamente instalada, causando sifoneado (agua desviándose hacia el interior de la lavadora).</p> <ul style="list-style-type: none"> Al instalar la manguera de drenaje, asegúrese de que esta no se retuerza o bloquee.
	<p>Al usar la función de secado, puede que se produzcan olores por la pelusa u otra materia de lavado que resulte adherida al calentador. (Únicamente modelos de secado)</p> <ul style="list-style-type: none"> Esto no es un problema de funcionamiento.
	<p>Un olor particular puede resultar al secar prendas húmedas con aire caliente. (Únicamente modelos de secado)</p> <ul style="list-style-type: none"> El olor desaparecerá luego de un corto tiempo.

Wi-Fi

Problemas	Causas posibles y solución
Problema al conectar el electrodoméstico y el teléfono inteligente a la red Wi-Fi.	<p>La contraseña de la red Wi-Fi fue ingresada incorrectamente.</p> <ul style="list-style-type: none"> Borre su red Wi-Fi doméstica e inicie el proceso de registro de nuevo.
	<p>Los Datos Móviles para su teléfono inteligente están activados.</p> <ul style="list-style-type: none"> Desactive los Datos móviles de su teléfono inteligente antes de conectar el electrodoméstico.
	<p>El nombre de la red inalámbrica (SSID) se ha configurado incorrectamente.</p> <ul style="list-style-type: none"> El nombre de la red inalámbrica (SSID) debe ser una combinación de letras y números. (No utilice símbolos especiales)
	<p>La frecuencia del enrutador no es de 2.4 GHz.</p> <ul style="list-style-type: none"> Sólo se admite una frecuencia de enrutador de 2.4 GHz. Configure el enrutador inalámbrico a 2.4 GHz y conecte el electrodoméstico a éste. Para verificar la frecuencia del enrutador, consulte con su proveedor de servicios de internet o con el fabricante del enrutador.
	<p>El electrodoméstico y el enrutador están demasiado separados.</p> <ul style="list-style-type: none"> Si el electrodoméstico se encuentra muy lejos del enrutador, puede que la señal sea débil y que la conexión no sea configurada correctamente. Coloque el enrutador más cerca del electrodoméstico o compre e instale un repetidor Wi-Fi.

GARANTÍA LIMITADA

EE. UU.

TÉRMINOS Y CONDICIONES

AVISO DE ARBITRAJE: ESTA GARANTÍA LIMITADA CONTIENE UNA CLÁUSULA DE ARBITRAJE QUE LES DEMANDA A USTED Y A LG ELECTRONICS (“LG”) A RESOLVER CONFLICTOS A TRAVÉS DE UN ARBITRAJE VINCULANTE EN LUGAR DE HACERLO EN LA CORTE, A MENOS QUE USTED DECIDA NO PARTICIPAR. EN EL ARBITRAJE NO ESTÁN PERMITIDAS LAS ACCIONES COLECTIVAS NI LOS JUICIOS CON JURADO. POR FAVOR, VEA A CONTINUACIÓN LA SECCIÓN TITULADA “PROCEDIMIENTO PARA RESOLVER CONFLICTOS”.

Si su lavadora LG (“Producto”) fallara debido a defectos de materiales o de fabricación en el uso doméstico normal y correcto, durante el período de garantía que se establece a continuación, LG tendrá la opción de reparar o reemplazar el Producto. Esta garantía limitada solo es válida para el comprador minorista original del Producto (“Usted”) y será vigente solo cuando se compre legalmente y se use dentro de los Estados Unidos y de los territorios estadounidenses.

PERÍODO DE GARANTÍA		
Arandela	Motor Direct Drive (Estator o rotor)	Tambor de acero inoxidable
Un (1) año a partir de la fecha original de compra	Diez (10) años a partir de la fecha original de compra	Diez (3) años a partir de la fecha original de compra
Piezas y Trabajo (Sólo piezas internas/funcionales)	Solo piezas (usted será responsable de cualquier costo de mano de obra).	Solo piezas (usted será responsable de cualquier costo de mano de obra).

- Los productos y las piezas de repuesto están garantizados durante el tiempo restante del período original de garantía o noventa (90) días, lo que resulte mayor.
- Los productos y las piezas de repuesto pueden ser nuevos, reparados, reacondicionados, o reconstruidos por la fábrica.
- Los productos y las piezas reemplazados deben ser propiedad de LG.
- A manera de obtener el servicio de garantía bajo esta Garantía Limitada, se requiere prueba de la compra original del producto especificando el modelo del mismo y la fecha de compra.
- La fecha de inicio de la garantía será de noventa (90) días desde la fecha de fabricación en ausencia del comprobante de compra válido.

SALVO DISPOSICIÓN LEGAL CONTRARIA, CUALQUIER GARANTÍA IMPLÍCITA DE POSIBILIDAD DE COMERCIALIZACIÓN O ADECUACIÓN DEL PRODUCTO PARA UNA FINALIDAD ESPECÍFICA ESTÁ LIMITADA EN DURACIÓN A AQUELLA DE LA GARANTÍA LIMITADA PRECEDENTE. BAJO NINGUNA CIRCUNSTANCIA LG NI SUS DISTRIBUIDORES/CONCESIONARIOS EN LOS ESTADOS UNIDOS SERÁN RESPONSABLES DE NINGÚN DAÑO INDIRECTO, INCIDENTAL, EMERGENTE, ESPECIAL NI PUNITIVO DE NINGÚN TIPO, LO QUE INCLUYE SIN LIMITACIONES, PÉRDIDA DEL BUEN NOMBRE DEL NEGOCIO, PÉRDIDA DE INGRESOS O GANANCIAS, CESACIÓN DEL EMPLEO, DETERIORO DE OTROS BIENES, COSTOS DE RETIRO Y REINSTALACIÓN DEL PRODUCTO, PÉRDIDA DE USO O CUALQUIER OTRO DAÑO BASADO EN CONTRATO, RESPONSABILIDAD CIVIL U OTROS. LA RESPONSABILIDAD TOTAL DE LG, SI EXISTE, NO SUPERARÁ EL PRECIO QUE USTED HAYA PAGADO POR EL PRODUCTO.

ALGUNOS ESTADOS NO PERMITEN LA EXCLUSIÓN O LIMITACIÓN DE DAÑOS INCIDENTALES O EMERGENTES, O LIMITACIONES A LA DURACIÓN DE LA GARANTÍA IMPLÍCITA, POR LO QUE LA EXCLUSIÓN O LIMITACIÓN ANTERIORMENTE MENCIONADAS PODRÍAN NO CORRESPONDER EN SU CASO. ESTA GARANTÍA LE OTORGA DERECHOS LEGALES ESPECÍFICOS Y ES POSIBLE QUE USTED CUENTE CON OTROS DERECHOS QUE VARÍAN SEGÚN EL ESTADO.

ESTA GARANTÍA LIMITADA NO CUBRE LO SIGUIENTE:

- Viajes del servicio técnico para entregar, buscar o instalar el producto, instruir al cliente sobre la operación del mismo, corregir el cableado o las reparaciones/instalaciones no autorizadas.
- Daño o fallo del producto al operar durante fallas e interrupciones del suministro eléctrico, o resultado de un servicio eléctrico inadecuado.
- Daños o fallo del producto causados por tuberías de agua rotas o con fugas, tuberías de agua congeladas, líneas de desagüe restringidas, suministro de agua inadecuado o interrumpido, o suministro de aire inadecuado.
- Daños o fallos del Producto resultantes de operar el Producto en una atmósfera corrosiva o de forma contraria al manual del propietario del Producto.
- Daños o fallos del producto causados por accidentes, pestes y alimañas, rayos, viento, incendio, inundaciones o hechos de fuerza mayor o cualquier otra causa ajena al control de LG.
- Daños o fallos del Producto causados por modificaciones o alteraciones no autorizadas, o si se usa para otro fin que no sea el previsto, o por fugas de agua donde el Producto no se haya instalado correctamente.
- Daños o fallos del Producto causados por corriente o voltaje eléctricos incorrectos, o por códigos de fontanería.
- Daños o fallos del Producto causados por el uso de piezas, accesorios, componentes, productos de limpieza consumibles, o cualquier otro producto, no aprobados por LG.
- Reemplazo de focos, filtros, fusibles o cualquier otra parte consumible.
- Daños o fallos del Producto causados por el transporte, el almacenamiento y/o el manejo que incluye rayas, muescas, astillado y otros daños al acabado del Producto, a menos que tales daños se informen dentro del plazo de una (1) semana de la entrega.
- Daños o artículos faltantes a productos comprados con descuento, con la caja abierta o que hayan estado en exhibición.
- Productos reacondicionados o cualquier producto vendido con los avisos "En el estado actual", "En el sitio actual", "Con todos sus defectos" o similares.
- Productos cuyos números de serie originales hayan sido retirados, alterados o no se puedan determinar fácilmente.
- Aumentos en los costos de los servicios públicos y otros gastos adicionales de dichos servicios.
- Cualquier ruido asociado con la operación normal.
- Productos usados de otra forma que no sea uso doméstico correcto y normal (p. ej., uso comercial o industrial, en oficinas, instalaciones recreativas o vehículos) o uso contrario al manual del propietario del Producto.
- Costos asociados con el retiro y la reinstalación de su producto para realizar reparaciones.
- Remoción y reinstalación del Producto si es instalado en una ubicación inaccesible o si no está instalado de acuerdo con el manual del propietario del Producto.
- Daños o fallos del Producto resultantes del mal uso, abuso, instalación, reparación o mantenimiento incorrectos o un servicio técnico no aprobado por LG.

El costo de la reparación o el reemplazo en las circunstancias excluidas mencionadas anteriormente estará a su cargo.

PARA OBTENER SERVICIO EN GARANTÍA E INFORMACIÓN ADICIONAL

Llame al 1-800-243-0000 y seleccione la opción apropiada desde el menú.

O visite nuestro sitio web en <http://www.lg.com>

O por correo postal a: LG Electronics Customer Service P.O. Box 240007 Huntsville, AL 35813 Atención: Atención al cliente

PROCEDIMIENTO PARA RESOLVER CONFLICTOS:

TODOS LOS CONFLICTOS ENTRE USTED Y LG QUE SURJAN FUERA DE O RELACIONADOS DE ALGUNA MANERA CON ESTA GARANTÍA LIMITADA O CON EL PRODUCTO, SE RESOLVERÁN EXCLUSIVAMENTE A TRAVÉS DE UN ARBITRAJE VINCULANTE Y NO EN UNA CORTE DE JURISDICCIÓN GENERAL. ARBITRAJE VINCULANTE SIGNIFICA QUE USTED Y LG RENUNCIAN AL DERECHO DE UN JUICIO CON JURADO Y A REALIZAR O PARTICIPAR EN UNA DEMANDA COLECTIVA.

Definiciones. Para el propósito de esta sección, las referencias a "LG" significan: LG Electronics U.S.A., Inc., sus empresas matrices, subsidiarias y filiales y cada uno de sus directivos, directores, empleados, agentes, beneficiarios, predecesores en interés, sucesores, cesionarios y proveedores; las referencias a "conflicto" o "reclamación" incluirán cualquier conflicto, reclamo o controversia de cualquier tipo, sin importar (ya sea basado en contrato, agravio, estatuto, regulación, ordenanza, fraude, falsa representación o cualquier teoría legal o equitativa) que surja de o esté relacionada con cualquier forma de venta, condición o desempeño del producto o de esta Garantía Limitada.

Aviso de disputa. En caso de que usted desee iniciar un procedimiento de arbitraje, primero debe notificar a LG por escrito al menos 30 días antes de iniciar el arbitraje enviando una carta a LG a LG Electronics, USA, Inc. Atención: Legal Department- Arbitration 111 Sylvan Avenue, Englewood Cliffs, NJ 07632. Usted y LG aceptan participar en discusiones de buena fe en un intento de resolver su reclamo de manera amistosa. En la carta debe proporcionar su nombre, dirección y número de teléfono; identificar el producto que es objeto de la reclamación; y describir la naturaleza del reclamo y el remedio que busca. Si usted y LG no pueden resolver la disputa dentro de 30 días, cualquiera de las partes puede proceder a presentar una demanda de arbitraje.

Acuerdo de arbitraje vinculante y renuncia de demanda colectiva. En caso de no resolver la disputa durante el período de 30 días después de enviar una notificación por escrito a LG, Usted y LG se comprometen a resolver cualquier reclamo entre nosotros, solamente a través de arbitraje vinculante sobre una base individual, a menos que usted se excluya, conforme a lo dispuesto a continuación. Cualquier conflicto entre usted y LG no estarán combinados o consolidados con una controversia relacionada con cualquier otro producto o reclamo de otra persona o entidad. Más específicamente y sin perjuicio de lo anterior, no procederá bajo ninguna circunstancia cualquier disputa entre usted y LG como parte de una acción colectiva o representativa. En lugar del arbitraje, cualquiera de las partes podrá iniciar una acción individual en la corte de reclamos menores, pero tales acciones en la corte de reclamos menores no podrán ser realizadas en una acción colectiva o representativa.

Normas y procedimientos de arbitraje. Para comenzar con el arbitraje de un reclamo, usted o LG deben realizar una demanda escrita para arbitraje. El arbitraje será administrado por la Asociación Americana de Arbitraje (AAA) y se llevará a cabo ante un árbitro único bajo las Normas de Arbitraje del Consumidor de la AAA, que tienen efecto al momento de inicio del arbitraje (en adelante "Normas de la AAA") y bajo los procedimientos establecidos en esta sección. Las Normas de la AAA están disponibles en línea en www.adr.org/consumer. Envíe una copia de su solicitud de arbitraje por escrito, así como una copia de esta disposición, a la AAA de la forma descrita en las Normas de la AAA. También debe enviar una copia de su solicitud por escrito a LG en LG Electronics, USA, Inc. Atención: Legal Department- Arbitration 111 Sylvan Avenue, Englewood Cliffs, NJ 07632. Si hay un conflicto entre las Normas de la AAA y las reglas establecidas en esta sección, prevalecerán dichas reglas de esta sección. Esta disposición de arbitraje se rige por la Ley Federal de Arbitraje. El juicio se puede introducir en el laudo arbitral en cualquier tribunal de jurisdicción competente. Todos son temas para que el árbitro tome sus decisiones, excepto aquellos asuntos relativos al alcance y aplicabilidad de la cláusula de arbitraje y de la capacidad de arbitraje de la controversia para que el tribunal decida. El árbitro se regirá por los términos de esta disposición.

Legislación vigente. La legislación del estado de su residencia regirá esta Garantía Limitada, así como todas las disputas entre nosotros, salvo que sea invalidada o inconsistente con leyes federales aplicables.

Tarifas / Costos. Usted no debe pagar ninguna tarifa para comenzar un arbitraje. Al recibir su solicitud de arbitraje por escrito, LG pagará todos los gastos administrativos rápidamente a la AAA, a menos que usted solicite más de \$25,000.00 por daños, en cuyo caso el pago de estos gastos se regirá por las Normas de la AAA. Salvo disposición contraria prevista en el presente documento, LG pagará a la AAA todos los gastos documentales, administrativos y de arbitraje para cualquier arbitraje iniciado, de conformidad con las Normas de la AAA y esta disposición de arbitraje. Si usted prevalece en el arbitraje, LG pagará los honorarios y gastos de sus abogados, siempre y cuando sean razonables, considerando factores que incluyen, entre otros, el monto de la compra y el monto del reclamo. No obstante lo anterior, si la ley aplicable permite una adjudicación de honorarios y gastos razonables de abogados, un árbitro puede otorgarlos en la misma medida que lo haría un tribunal. Si el árbitro considera que la sustancia de su

reclamo o la reparación solicitada en la demanda es frívola o se utiliza para un propósito inadecuado (calificado según las normas establecidas en la Norma Federal de Procedimiento Civil 11 (b)), el pago de todos los honorarios de arbitraje se regirá por las Normas de la AAA. En tal situación usted se compromete a reembolsar a LG todos los fondos erogados previamente por ella, cuyo pago es, por otra parte, su obligación, según las Normas de la AAA. Salvo disposición contraria, LG renuncia a cualquier derecho que pudiera tener para solicitarle los honorarios y gastos de sus abogados, si LG prevalece en el arbitraje.

Audiencias y ubicación. Si su reclamo es por \$25,000 o menos, usted puede optar que el arbitraje sea realizado únicamente sobre la base de: (1) documentos presentados al árbitro, (2) a través de una audiencia telefónica o (3) por una audiencia en persona, según lo establecido por las Normas de la AAA. Si su reclamo excede \$25,000, el derecho a una audiencia estará determinado por las Normas de la AAA. Cualquier audiencia de arbitraje en persona se realizará en un lugar dentro del distrito judicial federal en el cual resida, a menos que ambos acuerden otra ubicación o estemos de acuerdo con el arbitraje telefónico.

Exclusión. Usted puede quedarse fuera de este procedimiento de resolución de la disputa. Si se excluye, ni usted ni LG pueden solicitar al otro que participe en un procedimiento de arbitraje. Para excluirse usted debe enviar una notificación a LG, en un lapso de hasta 30 días continuos, contados a partir de la fecha de la primera compra del consumidor del producto, ya sea por: (i) el envío de un correo electrónico a optout@lge.com con el siguiente Asunto: "Exclusión del arbitraje" o (ii) llamada al 1-800-980-2973. Debe incluir en el correo electrónico de exclusión o suministrar por teléfono: (a) su nombre y dirección; (b) la fecha en la cual el producto fue comprado; (c) el nombre o el número del modelo del producto; y (d) el número del serial (el número del serial puede ser hallado (i) en el producto, o (ii) en la dirección de <https://www.lg.com/us/support/repair-service/schedule-repair-continued> al hacer clic en "Find My Model & Serial Number").

Sólo puede excluirse del procedimiento de resolución de conflictos en la forma descrita anteriormente (es decir, por correo electrónico o por teléfono); ninguna otra forma de notificación será efectiva para hacerlo. Excluirse de este procedimiento de resolución de controversias no afectará de ninguna manera la cobertura de la Garantía Limitada, por lo que usted continuará disfrutando de todos sus beneficios. Si conserva este producto y no se excluye, usted acepta todos los términos y condiciones de la cláusula de arbitraje descrita anteriormente.



MANUEL D'UTILISATION

LAVEUSE

Veillez lire attentivement le présent manuel de l'utilisateur avant de faire fonctionner l'appareil et conservez-le à portée de la main pour le consulter en tout temps.

FRANÇAIS

WM3600H*A



MFL71693706
Rev.00_061220

www.lg.com

Copyright © 2020 LG Electronics Inc. Tous droits réservés

TABLE DES MATIÈRES

3 CONSIGNES DE SÉCURITÉ IMPORTANTES

- 3 LISEZ TOUTES LES CONSIGNES AVANT L'UTILISATION
- 3 AVERTISSEMENTS
- 6 MISES EN GARDE

7 APERÇU DU PRODUIT

- 7 Caractéristiques du produit

9 INSTALLATION

- 9 Avant l'installation
- 10 Choix de l'emplacement adéquat
- 11 Déballage et retrait des matériaux d'expédition
- 12 Raccordement des tuyaux d'arrivée d'eau
- 13 Raccordement du tuyau de vidange
- 15 Mise au niveau de la laveuse
- 16 Vérification de l'installation finale

18 FONCTIONNEMENT

- 18 Avant l'utilisation
- 19 Tri des articles
- 20 Chargement de la laveuse
- 21 Ajout de produits de nettoyage
- 24 Panneau de commande
- 27 Cycles de lavage
- 31 Modificateurs de cycle
- 31 Autres options et fonctionnalités

34 FONCTIONS INTELLIGENTES

- 34 Utilisation de l'application LG ThinQ
- 37 Fonctionnalité Smart Diagnosis^{MC}

38 ENTRETIEN

- 38 Nettoyage régulier
- 38 Entretien périodique
- 42 Entretien dans les climats froids

44 DÉPANNAGE

- 44 Avant d'appeler le réparateur

54 GARANTIE LIMITÉE

- 54 POUR CANADA

CONSIGNES DE SÉCURITÉ IMPORTANTES

LISEZ TOUTES LES CONSIGNES AVANT L'UTILISATION

Messages de sécurité

Il est très important d'assurer votre sécurité et celle des autres.

Nous fournissons de nombreux conseils de sécurité importants dans ce manuel et sur votre appareil. Lisez toujours l'ensemble des messages de sécurité et respectez-les.



Ceci est le symbole d'alerte de sécurité.

Ce symbole vous alerte de dangers potentiels qui peuvent causer la mort ou des blessures. Tous les messages de sécurité seront précédés du symbole d'alerte de sécurité et du terme AVERTISSEMENT ou MISE EN GARDE.

Voici le message que ces mots véhiculent :



AVERTISSEMENTS

Vous pouvez être tué ou gravement blessé si vous ne suivez pas les consignes.



MISES EN GARDE

Vous pouvez être légèrement blessé ou pouvez endommager le produit si vous ne suivez pas les consignes.

Tous les messages de sécurité vous indiqueront quel est le danger potentiel, comment réduire les risques de blessures et ce qui peut se produire en cas de non-respect des consignes.

AVERTISSEMENTS

AVERTISSEMENT

- Pour réduire les risques d'explosion, d'incendie, de mort, de décharge électrique, de brûlure ou de blessures lors de l'utilisation de l'appareil, prenez les précautions élémentaires, y compris les suivantes :

Installation

- Respectez toutes les procédures de sécurité recommandées de l'industrie, incluant le port de gants à longs poignets et de lunettes de sécurité.
- N'essayez jamais d'utiliser cet appareil s'il est endommagé, défectueux ou partiellement désassemblé, s'il manque des pièces ou si des pièces, incluant le câble et la fiche, sont endommagées.
- Avant d'être utilisé, l'appareil doit être installé conformément aux directives de ce manuel.
- Pour réduire le risque de blessure grave ou de décès, suivez toutes les consignes d'installation.
- Consultez la section DIRECTIVES D'INSTALLATION pour voir la procédure détaillée de mise à la terre. Des directives d'installation sont incluses avec l'appareil pour que l'installateur puisse les consulter. Si vous déménagez l'appareil, faites-le inspecter et réinstaller par un technicien qualifié.
- Au moins deux personnes sont requises pour déplacer ou installer l'appareil.
- N'installez pas l'appareil dans un endroit humide.
- Entrez et installez l'appareil dans un endroit où il ne sera pas exposé à des températures sous le point de congélation ni aux intempéries.
- Cet appareil n'est pas conçu pour un usage nautique ou mobile, comme dans un véhicule récréatif, une roulotte ou un avion.
- Gardez le matériel d'emballage hors de portée des enfants. Le matériel d'emballage pose un danger pour les enfants. Il y a un risque de suffocation.

4 CONSIGNES DE SÉCURITÉ IMPORTANTES

- Détruisez l'emballage en carton, le sac en plastique et tout autre matériel d'emballage après avoir déballé l'appareil. Les enfants pourraient jouer avec ces articles. Le carton, lorsque recouvert de tapis, de draps ou de pellicule de plastique, peut se transformer en chambre étanche.
- L'appareil doit être installé et mis à la terre conformément au code du bâtiment local par le personnel qualifié.
- Lorsque vous installez ou déplacez l'appareil, faites attention de ne pas pincer, écraser, ni endommager le câble d'alimentation.
- Branchez l'appareil dans un circuit électrique à protection, à valeurs nominales et de taille adéquates pour éviter une surcharge électrique.
- Cet appareil doit être placé près d'une prise électrique.
- Débranchez le cordon d'alimentation, le fusible de maison ou le disjoncteur avant l'installation ou un entretien de l'appareil.
- Le cordon d'alimentation de cet appareil est équipé d'une fiche à trois broches (Mise à la terre) qui va dans une prise à trois trous (Mise à la terre) standard, afin de minimiser la possibilité d'électrocution.
- Ne coupez ni n'enlevez jamais la broche de mise à la terre du câble d'alimentation.
- Utilisez des tuyaux neufs pour raccorder la laveuse à l'alimentation en eau. Ne réutilisez pas des tuyaux usagés.

FONCTIONNEMENT

- Lisez toutes les instructions avant d'utiliser l'appareil et conservez ces instructions.
- N'utilisez l'appareil qu'aux fins pour lesquelles il est conçu.
- Si le produit a été immergé dans l'eau, s'il a reposé dans l'eau stagnante ou s'il s'est retrouvé gorgé d'eau, ne lui touchez surtout pas et contactez immédiatement le Centre d'information à la clientèle de LG Electronics pour obtenir des instructions avant de reprendre l'utilisation.
- Si vous entendez un son étrange, si vous détectez une odeur de produit chimique ou de brûlé, ou si vous voyez de la fumée provenant de l'appareil, débranchez-le immédiatement et communiquez avec le Centre d'information à la clientèle de LG Electronics.
- Dans certaines conditions, de l'hydrogène peut se former dans un système d'eau chaude qui pas été utilisé pendant deux semaines ou plus. L'HYDROGÈNE EST UN GAZ EXPLOSIF. Si le système d'eau chaude n'a pas servi pendant une telle durée, ouvrez tous les robinets d'eau chaude et laissez l'eau couler pendant plusieurs minutes avant d'utiliser l'appareil. Cette procédure permettra d'évacuer toute trace d'hydrogène accumulé. Comme l'hydrogène est un gaz inflammable, ne fumez pas pendant ce temps, et n'utilisez pas de feu.
- Ne mettez pas vos mains dans l'appareil si la cuve, le tambour, l'agitateur ou toute autre partie bouge. Avant de charger, de décharger ou d'ajouter des articles, appuyez sur le bouton Démarrer/pause et attendez que la cuve ou le tambour s'arrête complètement avant de mettre vos mains à l'intérieur.
- Cet appareil n'est pas destiné à être utilisé par des personnes (incluant des enfants) dont les capacités physiques, mentales ou sensorielles sont réduites, ou qui n'ont pas l'expérience ou les connaissances pour le faire, à moins d'avoir reçu des instructions et d'avoir été supervisées par une personne responsable de leur sécurité.
- Ne laissez pas les enfants ou les animaux jouer dans, avec ou sur l'appareil. Vous devez superviser de près les enfants ou les animaux lorsque vous utilisez l'appareil et qu'ils sont à proximité.
- Gardez les produits de lessive hors de la portée des enfants. Pour prévenir les blessures, respectez tous les avertissements sur les étiquettes des produits.
- Réparez ou remplacez immédiatement tout câble d'alimentation effiloché ou endommagé. N'utilisez pas un câble avec des fissures ou des dommages d'abrasion sur sa longueur ou sur une de ses extrémités.
- Ne débranchez jamais l'appareil en tirant sur le cordon d'alimentation. Prenez toujours la fiche fermement et tirez-la de la prise de courant.
- N'utilisez pas de rallonge électrique ni d'adaptateur avec cet appareil.

- Ne saisissez pas le cordon d'alimentation et ne touchez pas les boutons de l'appareil avec les mains mouillées.
- Ne modifiez et ne prolongez pas le cordon d'alimentation.
- Si le cordon d'alimentation électrique est endommagé, il doit être remplacé par le fabricant uniquement ou par son agent de service ou encore une personne qualifiée possédant ce type de compétences pour éviter un risque.
- Ne placez pas d'articles huileux ou gras, de chandelles ou de matières inflammables au-dessus de l'appareil.
- Veillez à maintenir la zone située en-dessous et autour de vos appareils électroménagers dégagée de matières combustibles (peluche/charpie, papier, chiffons, etc.), d'essence, de produits chimiques et d'autres vapeurs ou liquides inflammables.
- N'entreposez ou n'utilisez pas d'essence ou d'autres vapeurs inflammables à proximité de cet appareil ou d'autres appareils.
- Ne mélangez pas de javellisant chloré avec des agents acides comme le vinaigre. Suivez les directives de l'emballage lorsque vous utilisez des produits de lessive. Une utilisation incorrecte pourrait produire des gaz toxiques pouvant causer des blessures graves ou la mort.
- N'utilisez jamais de nettoyeurs forts, de nettoyeurs abrasifs, ni de solvants pour nettoyer la laveuse. Ils peuvent endommager le fini.
- Ne lavez pas les articles préalablement nettoyés, lavés, imbibés ou tachés avec de l'essence, des solvants de nettoyage à sec, de l'huile végétale, de l'huile de cuisson ou d'autres substances inflammables ou explosives, car ces substances dégagent des vapeurs susceptibles de s'enflammer ou d'exploser.
- N'ajoutez pas d'essence, de solvants de nettoyage à sec ou autres substances inflammables ou explosives dans l'eau de lavage. Ces substances dégagent des vapeurs qui peuvent s'enflammer ou exploser.
- En cas de fuite de gaz (propane, gaz naturel, etc.), ne faites pas fonctionner cet appareil ni tout autre appareil. Ouvrez immédiatement une fenêtre ou une porte pour aérer la zone.
- Ne modifiez pas les commandes.
- Fixez solidement le tuyau de vidange pour éviter les inondations.
- Ne forcez pas la porte et ne posez pas votre poids sur la porte de l'appareil.
- Vérifiez toujours s'il y a des objets inhabituels à l'intérieur de l'appareil.
- Ne laissez pas d'eau, de javellisant ou d'autres liquides reposer dans le tambour pendant de longues périodes. Cela pourrait entraîner la corrosion du tambour ou causer de la moisissure ou de mauvaises odeurs.

Entretien

- Ne réparez ou ne remplacez aucune pièce de l'appareil. Toutes les réparations et tous les entretiens doivent être effectués par un technicien d'entretien qualifié, à moins qu'il y ait d'autres recommandations précises dans ce manuel d'utilisation. N'utilisez que des pièces d'origine autorisées.
- Débranchez cet appareil de la prise électrique avant de le nettoyer et avant toute tentative d'entretien. L'utilisation du panneau de commande pour éteindre l'appareil ne coupe pas l'alimentation.
- Retirez toute poussière ou tout corps étranger des fentes du câble d'alimentation.
- Ne désassemblez pas et ne réparez pas l'appareil vous-même.
- Avant de mettre la laveuse hors service ou au rebut, retirez-en la porte pour éviter que des enfants ou des petits animaux y soient accidentellement enfermés.
- Assurez-vous que le tiroir ou le rabat du distributeur est fermé en tout temps quand on ne le remplit pas de produits pour la lessive.

Instructions de mise à la terre

- La connexion incorrecte du conducteur pour relier les appareils à la terre peut créer un risque de décharge électrique. Vérifiez avec un électricien compétent ou un personnel de service si vous n'êtes pas certain que l'appareil est correctement mis à la terre. Ne modifiez pas la fiche fournie avec l'appareil; si elle ne rentre pas dans la prise, faites installer une prise appropriée par un électricien compétent.
- L'appareil doit être mis à la terre. En cas d'un mauvais fonctionnement ou d'une panne, la mise à terre réduira le risque de décharge électrique en fournissant le moins de résistance pour le courant électrique. L'appareil est équipé d'un cordon avec un conducteur pour relier les appareils à la terre. La fiche doit être branchée sur une prise appropriée, installée et reliée à la terre conformément aux codes et règlements locaux.

MISES EN GARDE

MISE EN GARDE

- Pour réduire les risques de blessures mineures, de pannes ou de dommages causés à l'appareil ou à la propriété lors de l'utilisation de l'appareil, prenez les précautions élémentaires, y compris les suivantes :
-

Installation

- Installez le produit sur un plancher ferme et au niveau.

FONCTIONNEMENT

- Ne placez pas d'objets sur le dessus de l'appareil.
- Fermez les robinets d'eau et débranchez l'appareil si vous quittez votre résidence pendant longtemps, comme lorsque vous partez en voyage.
- Suivez TOUJOURS les directives d'entretien du fabricant des articles.
- Utilisez uniquement de l'assouplissant ou des produits antistatiques conformément aux recommandations du fabricant.
- Ne combinez pas des produits de lessive dans une même brassée sauf si l'étiquette indique de le faire.
- Ne touchez pas à l'eau de vidange, qui peut être brûlante.
- Si le tuyau de vidange et le tuyau d'alimentation en eau sont gelés, dégelez-les avant d'utiliser l'appareil.
- Ne rangez pas et ne renversez pas les détergents liquides, les nettoyants ou les javellisants (au chlore ou à l'oxygène) sur le dessus de l'appareil. Cela pourrait entraîner de la corrosion, de la décoloration ou des dommages à la surface de l'appareil.
- Les vêtements ou les articles imperméables ou résistants à l'eau doivent être lavés à l'aide du cycle Imperméable seulement. (Par exemple, les vêtements résistants à l'eau, les housses de matelas, les vêtements de plein air, les tapis en plastique, etc.) Autrement, cela pourrait causer des blessures corporelles ou des dommages à la laveuse, aux vêtements, aux murs, au plancher et aux objets environnants en raison de vibrations anormales.

GARDEZ CES CONSIGNES

APERÇU DU PRODUIT

Caractéristiques du produit

Les illustrations contenues dans ce manuel peuvent être différentes des composants et accessoires réels, et ceux-ci peuvent être modifiés sans préavis par le fabricant dans le but d'améliorer le produit.

⚠ AVERTISSEMENT

- Pour votre sécurité et pour prolonger la durée de vie du produit, n'utilisez que des composants autorisés. Le fabricant décline toute responsabilité en cas de dysfonctionnement du produit, de dommages matériels ou de dommages corporels causés par l'utilisation de composants, de pièces ou de produits non autorisés de marque autre que LG achetés séparément.

Vue de l'avant

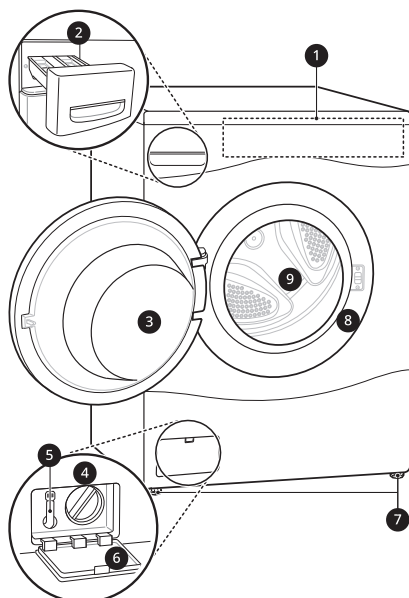

- ❶ Panneau de commande
- ❷ Tiroir du distributeur de détergent
- ❸ Porte
- ❹ Filtre de la pompe de vidange
- ❺ Tuyau de vidange
- ❻ Couvercle du filtre de la pompe de vidange
- ❼ Pieds de nivellement
- ❽ Joint de la porte
- ❾ Tambour

Vue de l'arrière

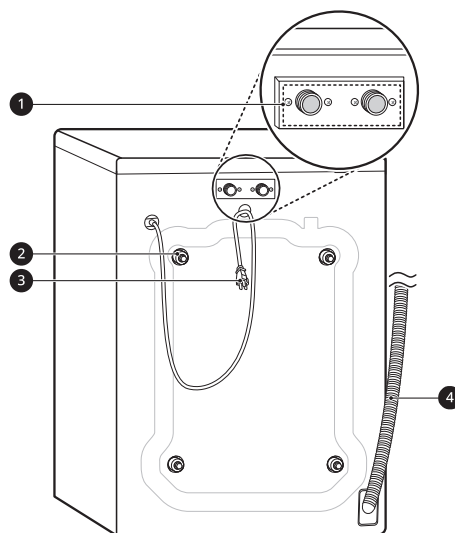

- ❶ Arrivées d'eau
- ❷ Boulons d'expédition
- ❸ Cordon d'alimentation
- ❹ Tuyau de vidange

Accessoires

Accessoires inclus

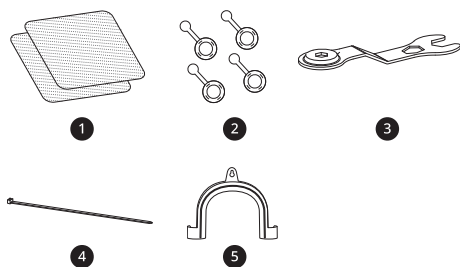

- ❶ Patins antidérapants
- ❷ Cache-trous
- ❸ Clé
- ❹ Sangle d'attache
- ❺ Attache coudée (pour fixer le tuyau de vidange)

Accessoires requis

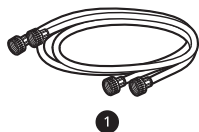

- ❶ Tuyaux d'eau chaude et d'eau froide

Accessoires optionnels

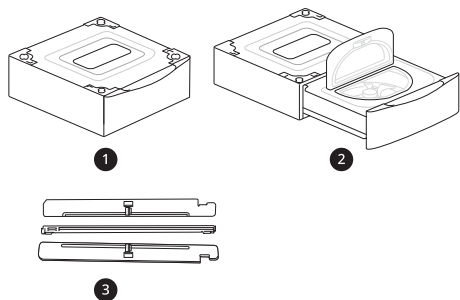

- ❶ Piédestal
- ❷ Laveuse sur piédestal
- ❸ Trousse de superposition

Caractéristiques du produit

Modèle	WM3600H*A
Alimentation électrique	120 V c.a. - 60 Hz
Pression d'eau minimale et maximale	De 20 à 120 psi (de 138 à 827 kPa)
Dimensions (largeur x hauteur x profondeur)	27 po X 39 po X 30 1/4 po (70 cm X 99 cm X 77 cm)
Profondeur maximale avec la porte ouverte	139,6 cm (55 po)
Poids net	90 kg (198,4 lb)
Vitesse d'essorage maximale	1 300 tr/min

INSTALLATION

Avant l'installation

Aperçu de l'installation

Veillez d'abord lire ces instructions d'installation après avoir acheté cette laveuse ou après l'avoir transportée à un autre endroit.

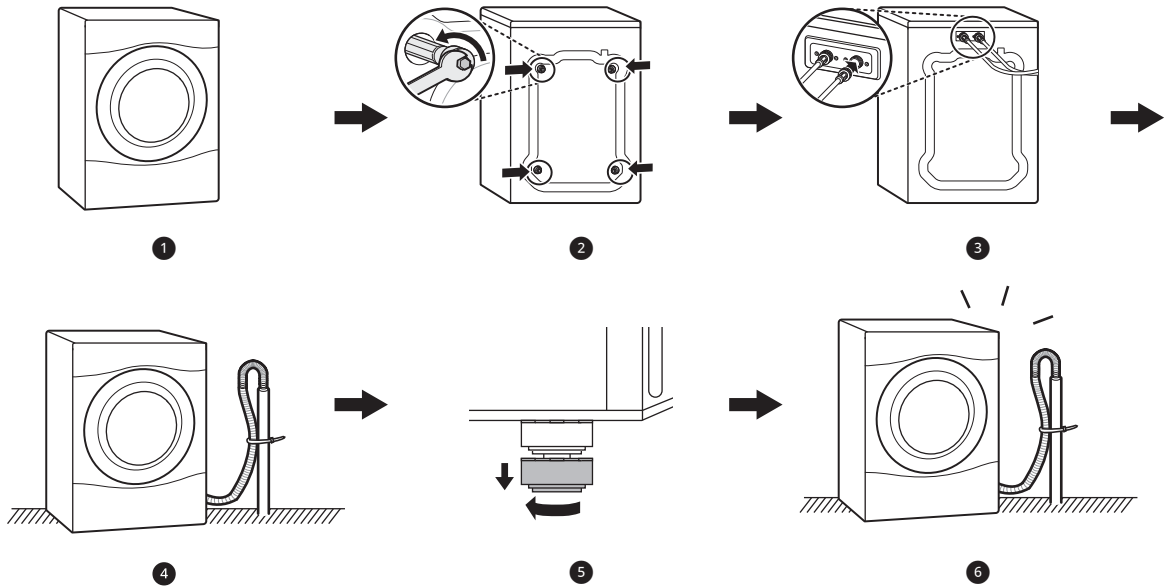

- ❶ Choix de l'emplacement adéquat
- ❷ Déballage et retrait des matériaux d'expédition
- ❸ Raccordement des tuyaux d'arrivée d'eau
- ❹ Raccordement du tuyau de vidange
- ❺ Mise au niveau de la laveuse
- ❻ Vérification de l'installation finale

⚠ AVERTISSEMENT

- Au moins deux personnes sont requises pour déplacer ou installer l'appareil. Le non-respect de cette consigne peut entraîner des blessures.
- Entrez et installez l'appareil dans un endroit où il ne sera pas exposé à des températures sous le point de congélation ou aux intempéries. Le non-respect de cet avertissement peut causer une défaillance du produit ou d'une pièce, des blessures graves, un incendie, une décharge électrique ou la mort.
- Faites la mise à la terre de la laveuse conformément à tous les codes et ordonnances en vigueur. Le non-respect de cet avertissement peut causer des blessures graves, un incendie, une décharge électrique ou la mort.
- Pour assurer une circulation adéquate de l'air, ne bloquez pas la grande ouverture au bas de la laveuse avec du tapis ou autre.
- Ne retirez pas la broche de mise à la terre du cordon d'alimentation. N'utilisez pas d'adaptateur ni de rallonge. Branchez la fiche dans une prise pour 3 broches mise à la terre. Le non-respect de cet avertissement peut causer des blessures graves, un incendie, une décharge électrique ou la mort.

⚠ AVERTISSEMENT

- Certaines pièces internes qui ne sont pas mises à la terre intentionnellement posent un risque de décharge électrique durant l'entretien seulement. Remarque à l'intention du personnel d'entretien – Évitez tout contact avec les pièces suivantes lorsque l'appareil est sous tension : la pompe, la soupape, le moteur et le panneau de commande.

Outils nécessaires



- ① Pincettes
- ② Tournevis plat
- ③ Niveau

Choix de l'emplacement adéquat

Avant d'installer la laveuse, vérifiez les exigences suivantes concernant l'emplacement d'installation.

- Allouez suffisamment d'espace entre les murs et la laveuse pour l'installation.
- Vérifiez que le plancher est propre, sec et exempt de poussières, de saletés, d'eau ou d'huile afin que les pieds de nivellement ne glissent pas. Des pieds de nivellement qui peuvent se déplacer et glisser sur le plancher peuvent entraîner des vibrations et un bruit excessifs.
- Si le plancher est trop flexible, renforcez-le pour qu'il soit plus résistant. Si le plancher n'est pas solide, cela pourrait produire de fortes vibrations et beaucoup de bruit.
- Si un bac de vidange doit être utilisé, faites très attention de bien suivre les directives fournies avec ce dernier et assurez-vous que les pieds de nivellement entrent fermement en contact avec le bac. L'usage d'un bac de vidange et un mauvais nivellement de la laveuse pourraient accroître les vibrations et le bruit durant le fonctionnement.

Prise électrique

- La prise électrique doit être à **1,5 m (60 po)** ou moins d'un des côtés de la laveuse.
- Positionnez la laveuse de façon à ce que la prise électrique et la fiche soient facilement accessibles.

- Ne surchargez pas la prise de courant avec plus d'un appareil.
- La prise doit être mise à la terre conformément aux règlements actuels concernant les installations électriques.
- Utilisez un fusible à fusion lente ou un disjoncteur.
- Le propriétaire de la laveuse a l'obligation et la responsabilité de faire installer une prise électrique adéquate par un électricien qualifié.

Plancher

- Pour minimiser le bruit et les vibrations, installez la laveuse sur un plancher ferme, au niveau et suffisamment résistant pour supporter son poids sans flexion ni rebond.
- La laveuse doit être installée sur un plancher ferme pour minimiser les vibrations durant le cycle d'essorage. La surface idéale est un plancher de béton, mais un plancher en bois suffit, pourvu qu'il soit construit conformément aux normes de la FHA.
- Le plancher sous la laveuse ne doit pas avoir une inclinaison supérieure à 2,5 cm (1 pouce) de l'avant à l'arrière ou d'un côté à l'autre.
- Il n'est pas recommandé d'installer l'appareil sur du tapis ou des tuiles en matériau souple.
- N'installez jamais la laveuse sur une plateforme ou une structure mal soutenue.

Installation sur le plancher

Afin d'assurer un dégagement suffisant pour les tuyaux d'arrivée d'eau, le tuyau de vidange et pour la circulation d'air, il doit y avoir au moins **2,5 cm (1 pouce)** d'espace libre de chaque côté de la laveuse et **10 cm (4 pouces)** d'espace libre derrière celle-ci. Assurez-vous de tenir compte des murs, des portes et des moulures de plancher qui

pourraient augmenter les dégagements nécessaires.

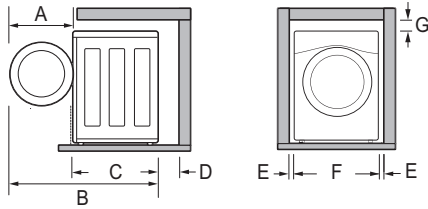

Dimensions et dégagements	
A	62,6 cm (24 3/4 po)
B	139,6 cm (55 po)
C	77 cm (30 1/4 po)
D	10 cm (4 po)
E	2,5 cm (1 po)
F	70 cm (27 po)
G	0,5 cm (1/4 po)

Installation superposée ou sur piédestal

La laveuse peut être installée sous une sècheuse ou sur un piédestal ou une laveuse sur piédestal.

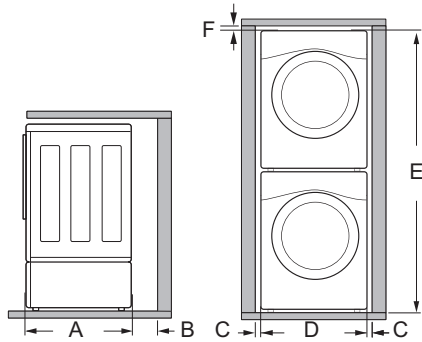

Dimensions et dégagements	
A	77 cm (30 1/4 po)
B	10 cm (4 po)
C	0,5 cm (1 po)
D	70 cm (27 po)
E	196,8 cm (77 1/2 po)
F	0,5 cm (1/4 po)

REMARQUE

- Suivez les directives incluses avec l'ensemble de piédestal optionnel avant d'installer la laveuse sur le piédestal.

- N'utilisez pas un plateau d'égouttement lorsque vous installez un piédestal ou une laveuse sur piédestal, puisque cela pourrait bloquer le tiroir. L'utilisation d'un plateau d'égouttement peut entraîner une augmentation des vibrations et du bruit pendant le fonctionnement.

Déballage et retrait des matériaux d'expédition

Retirez tous les matériaux d'expédition de la laveuse pour assurer un fonctionnement adéquat et inspectez l'appareil pour vérifier s'il a été endommagé pendant l'expédition.

⚠ MISE EN GARDE

- L'omission de retirer le matériel d'expédition peut entraîner du bruit excessif et des vibrations.

Retrait des matériaux d'expédition

* Cette fonctionnalité est offerte sur certains modèles seulement.

Soulevez la laveuse de la base en styromousse.

- Après avoir retiré la boîte en carton et l'emballage d'expédition, soulevez la laveuse de la base en styromousse.
- Assurez-vous que le support en plastique du tambour ①* se détache de la base et ne reste pas collé au fond de la laveuse.
- Si vous devez mettre la laveuse sur le côté pour enlever la boîte de la base ②, protégez toujours le côté de la laveuse, et placez-la soigneusement sur le côté. Ne couchez pas la laveuse sur sa surface avant ou arrière.

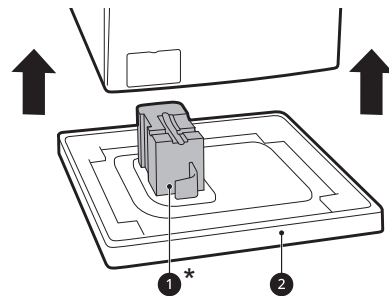

Retrait des matériaux d'expédition

- 1 Retirez les assemblages de boulons.
 - Commencez par les deux boulons d'expédition inférieurs ③ et utilisez la clé incluse pour desserrer complètement les

quatre boulons d'expédition en les tournant dans le sens inverse des aiguilles d'une montre.

- Retirez les assemblages de boulons (boulons et bagues d'arrêt) en les agitant légèrement tout en les tirant.

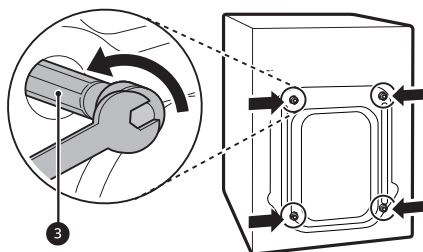

2 Installez les cache-trous.

- Localisez les cache-trous ④ inclus dans l'ensemble d'accessoires ou fixés à l'arrière de la laveuse. Installez les cache-trous dans les trous laissés par les assemblages de boulons.

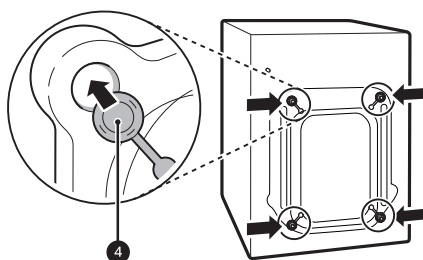

⚠ MISE EN GARDE

- Une fois les assemblages de boulons retirés, conservez-les pour une utilisation ultérieure. Afin d'éviter d'endommager les composants internes, ne transportez pas la laveuse sans avoir réinstallé les boulons d'expédition. Si vous ne retirez pas les boulons d'expédition et les bagues d'arrêt, vous risquez de provoquer de fortes vibrations et du bruit, ce qui peut entraîner des dommages permanents à la laveuse.

REMARQUE

- Le cordon d'alimentation est fixé à l'arrière de la laveuse à l'aide d'un boulon d'expédition pour aider à prévenir l'utilisation de l'appareil alors que les boulons d'expédition sont encore en place.

Raccordement des tuyaux d'arrivée d'eau

Pour éviter les risques de dégâts d'eau coûteux, achetez et installez de nouveaux tuyaux d'arrivée d'eau au moment d'installer la laveuse.

⚠ AVERTISSEMENT

- Ne serrez pas trop les tuyaux et ne faussez pas les raccords filetés. Un serrage excessif ou le faussement des raccords peut endommager les soupapes ou les raccords, ce qui peut causer des fuites et des dégâts matériels.
- Ne réutilisez pas de vieux tuyaux. Utilisez uniquement des tuyaux neufs lorsque vous installez la laveuse. Les tuyaux usagés pourraient fuir ou éclater, causant des inondations et des dommages matériels. Communiquez avec le centre d'information à la clientèle de LG pour obtenir de l'aide pour l'achat de tuyaux.

REMARQUE

- Vérifiez régulièrement les tuyaux pour détecter des fissures, des fuites et des signes d'usure; remplacez les tuyaux tous les cinq ans.
- Ne tendez pas intentionnellement les tuyaux d'eau et assurez-vous qu'ils ne sont pas pincés, écrasés ou pliés par d'autres objets.
- La pression d'entrée de l'eau doit se situer entre **20 psi et 120 psi (138 et 827 kPa)**. Si la pression d'entrée de l'eau est supérieure à **120 psi**, une soupape de réduction de pression doit être installée.
- L'eau chaude doit être réglée de manière à ce qu'elle soit distribuée à une température située entre **48 et 57 °C (120 et 135 °F)** pour permettre à la laveuse de bien contrôler les différentes températures de lavage.
- N'installez pas ou n'entrez pas la laveuse dans un endroit exposé à des températures sous le point de congélation. Cela pourrait endommager les tuyaux d'arrivée d'eau et les mécanismes internes de la laveuse. Si la laveuse a été exposée à des températures sous le point de congélation avant d'être installée, laissez-la reposer à la température de la pièce pendant plusieurs heures avant de l'utiliser, et vérifiez qu'il n'y a pas de fuites avant de la faire fonctionner.
- N'utilisez pas de tuyaux de prévention des inondations dotés de dispositifs d'arrêt automatique. Les dispositifs peuvent se

déclencher pendant le remplissage et empêcher la laveuse de se remplir correctement.

Raccordement des tuyaux d'arrivée d'eau

- 1 Vérifiez les raccords et les joints d'étanchéité. Inspectez le raccord fileté sur chaque tuyau et vérifiez qu'une rondelle d'étanchéité en caoutchouc ❶ est en place aux deux extrémités de chaque tuyau pour empêcher les fuites.

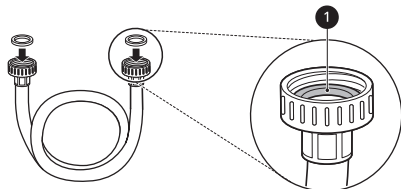

- 2 Raccordez les tuyaux d'arrivée d'eau.

- Raccordez les tuyaux d'arrivée d'eau aux robinets d'eau chaude et froide en les vissant d'abord fermement à la main, puis en serrant encore de deux tiers de tour à l'aide de pinces.
- Raccordez le tuyau bleu au robinet d'eau froide et le tuyau rouge au robinet d'eau chaude.

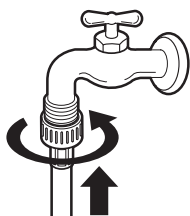

- 3 Purgez les tuyaux d'arrivée d'eau.

- Après avoir raccordé les tuyaux, ouvrez les robinets pour purger toute substance étrangère, comme de la saleté, du sable ou du bran de scie.
- Recueillez l'eau dans un sceau et vérifiez sa température afin de vous assurer d'avoir connecté les tuyaux aux bons robinets.

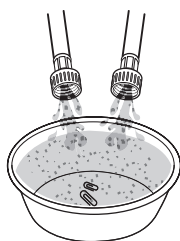

- 4 Raccordez les tuyaux d'arrivée à l'arrière de la laveuse.

- Raccordez le tuyau d'eau chaude à l'arrivée d'eau chaude à l'arrière de la laveuse. Raccordez le tuyau d'eau froide à l'arrivée d'eau froide à l'arrière de la laveuse.
- Serrez fermement les connecteurs. Ouvrez complètement les deux robinets et vérifiez qu'il n'y a pas de fuite aux deux extrémités des tuyaux.

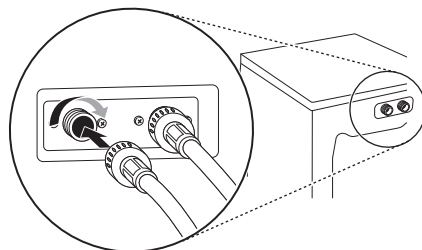

Raccordement du tuyau de vidange

Connectez le tuyau de vidange à un tuyau vertical ou à une cuve de lessive.

⚠ AVERTISSEMENT

- Le tuyau de vidange doit toujours être bien fixé. Le non-respect de cette consigne peut causer une inondation et des dommages matériels.

REMARQUE

- Le drain doit être installé conformément aux règlements applicables.
- Assurez-vous que le tuyau de vidange n'est pas étiré, pincé, écrasé ou déformé.
- N'installez pas l'extrémité de sortie des tuyaux à une hauteur inférieure à **75 cm (29,5 po)** ou supérieure à **244 cm (96 po)** au-dessus du bas de la laveuse, ou à plus de **152 cm (60 po)** de la laveuse.
- Ne créez jamais de joint étanche entre le tuyau et le drain avec du ruban ou un autre dispositif. Sans circulation d'air, l'eau pourrait être siphonnée du tambour, ce qui réduirait le rendement du lavage et du rinçage, et pourrait endommager les vêtements.

Utilisation d'un tuyau vertical pour la vidange

- 1 Fixez l'extrémité du tuyau dans l'attache coudée.
 - Connectez l'attache coudée ❶ à moins de **10 cm (4 po)** de l'extrémité du tuyau de vidange. Si le tuyau de vidange s'étend sur une longueur de plus de **10 cm (4 po)** de l'attache coudée, de la moisissure ou des microorganismes pourraient se propager à l'intérieur de la laveuse.

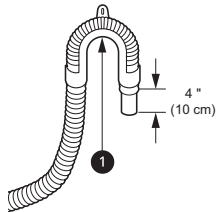

- 2 Insérez l'extrémité du tuyau de vidange dans le tuyau vertical.

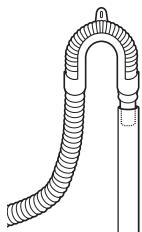

- 3 Utilisez la sangle d'attache fournie ❷ pour maintenir le tuyau de vidange en place.

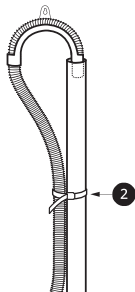

- 4 Si les soupapes d'eau et le drain se trouvent dans le mur, fixez le tuyau de vidange à l'un des tuyaux d'eau à l'aide de la sangle d'attache fournie ❸ (face ondulée vers l'intérieur).

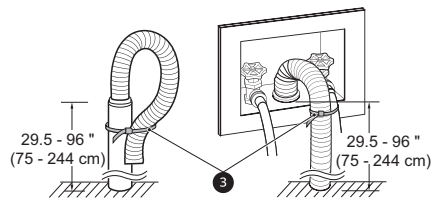

Utilisation d'une cuve de lessive pour la vidange

- 1 Fixez l'extrémité du tuyau dans l'attache coudée.
 - Connectez l'attache coudée ❶ à moins de **10 cm (4 po)** de l'extrémité du tuyau de vidange. Si le tuyau de vidange s'étend sur une longueur de plus de **10 cm (4 po)** de l'attache coudée, de la moisissure ou des microorganismes pourraient se propager à l'intérieur de la laveuse.

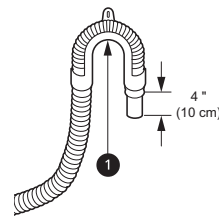

- 2 Accrochez l'extrémité du tuyau de vidange sur le côté de la cuve.

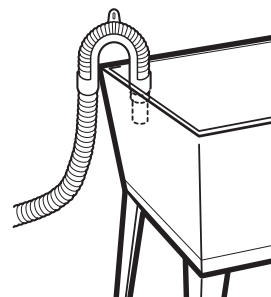

- 3 Utilisez la sangle d'attache fournie pour maintenir le tuyau de vidange en place.

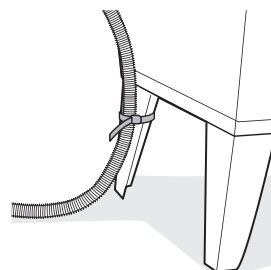

Mise au niveau de la laveuse

Le tambour de la laveuse tourne à une très grande vitesse. Pour réduire les vibrations, les bruits et tout déplacement accidentel de l'appareil, le plancher doit être stable et au niveau.

⚠ MISE EN GARDE

- Le fait d'utiliser la laveuse sans la mettre d'abord au niveau peut provoquer un dysfonctionnement consécutif à une production excessive de vibrations et de bruits.
- Ajustez les pieds de nivellement uniquement pour les besoins de la mise au niveau de la laveuse. Les allonger plus que nécessaire pourrait provoquer des vibrations à la laveuse.

REMARQUE

- Avant d'installer la laveuse, vérifiez que le plancher est propre, sec et exempt de poussières, de saletés, d'eau ou d'huile afin que les pieds de la laveuse ne glissent pas. Si les pieds peuvent se déplacer et glisser sur le plancher, cela peut entraîner des vibrations et un bruit excessifs.

Mise au niveau de la laveuse

- 1 Placez la laveuse dans son emplacement choisi.
 - Faites bien attention de ne pas pincer, coincer ou écraser les tuyaux d'arrivée d'eau et de vidange. Si vous possédez un niveau de menuisier ①, vous pouvez l'utiliser pour vérifier si la laveuse est au niveau. La pente sous la laveuse ne doit pas dépasser **2,5 cm (1 po)**, et les quatre pieds de nivellement doivent reposer fermement sur le sol.

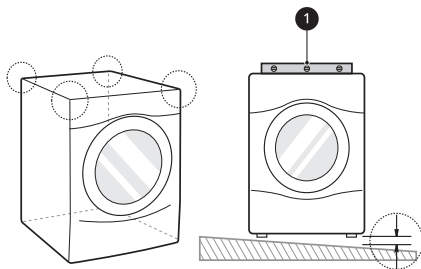

- 2 Réglez les pieds de nivellement.
 - Tournez les quatre pieds de nivellement dans une direction pour soulever la laveuse ou dans l'autre pour l'abaisser.

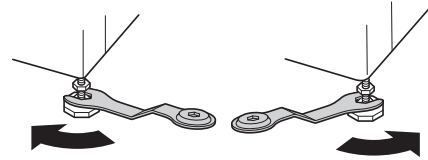

- 3 Vérifiez le niveau à nouveau.
 - En appuyant sur les bords supérieurs, tentez de faire basculer doucement la laveuse pour vous assurer qu'elle est stable. Si la laveuse bascule, réajustez les pieds de nivellement.

- 4 Serrez les écrous. ②
 - Tournez les écrous dans le sens contraire des aiguilles d'une montre et serrez-les quand la laveuse est au niveau.

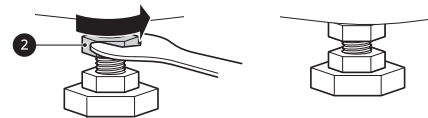

Utilisation de patins antidérapants

Si vous installez la laveuse sur une surface glissante, elle peut bouger en raison de vibrations excessives. Si la laveuse n'est pas au niveau, elle pourrait mal fonctionner, et produire du bruit et des vibrations. Si ceci se produit, installez les patins antidérapants sous les pieds de nivellement et réglez le niveau.

- 1 Nettoyez le plancher et installez les patins antidérapants.
 - Utilisez un chiffon sec pour nettoyer et enlever les objets étrangers ou l'humidité. Si le plancher est humide, les patins antidérapants pourraient glisser.
- 2 Mettez la laveuse au niveau après l'avoir placée dans la zone d'installation.

3 Placez le côté adhésif **3** des patins antidérapants sur le plancher.

- Les patins antidérapants sont plus efficaces lorsqu'ils sont installés sous les pieds avant. S'il est trop difficile d'installer les patins sous les pieds avant, installez-les sous les pieds arrière.

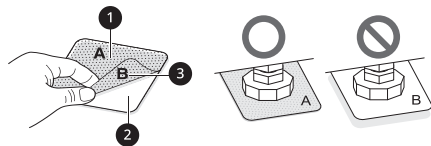

- 1 Ce côté vers le haut
- 2 Retirez la bande protectrice

4 Vérifiez de nouveau le niveau de la laveuse.

- En appuyant sur les bords supérieurs, tentez de faire basculer doucement la laveuse pour vous assurer qu'elle est stable. Si la laveuse bascule, remettez-la au niveau.

Vérification de l'installation finale

Branchement électrique

Branchez la laveuse sur une prise de courant à trois broches, mise à la terre, de **120 V c.a. et 60 Hz**.

⚠ AVERTISSEMENT

- N'utilisez pas le câble électrique si la gaine ou le connecteur sont endommagés ou usés. Remplacez-le ou réparez-le immédiatement. Le non-respect de cette directive peut causer la mort, un incendie, une décharge électrique ou une défaillance.
- Ne modifiez pas le cordon ni la fiche électrique fournis avec cet appareil. Assurez-vous de ne pas les endommager en installant ou en déplaçant l'appareil. Le non-respect de cette directive peut causer la mort, un incendie, une décharge électrique ou une défaillance.
- Assurez-vous que l'appareil est mis à la terre.
- Branchez cet appareil sur une prise électrique mise à la terre et dotée d'une tension nominale correspondant à la tension indiquée sur la plaque signalétique avant de l'utiliser. Le non-respect de cette directive peut causer un incendie, une décharge électrique ou une défaillance.

- Ne coupez ou n'endommagez jamais la broche de mise à la terre du câble d'alimentation. Le non-respect de cette directive peut causer la mort, un incendie, une décharge électrique ou une défaillance.
- Un raccordement incorrect du conducteur de mise à la terre de l'appareil peut entraîner un risque de décharge électrique. Consultez un électricien ou un technicien d'entretien qualifié si vous avez un doute à savoir si l'appareil est correctement mis à la terre. Si l'appareil ne peut pas être branché sur la prise de courant, faites installer une prise adéquate par un électricien qualifié.
- L'appareil doit être placé de façon à ce que la prise électrique reste facile d'accès.
- N'utilisez pas d'adaptateur ni de rallonge. Le non-respect de cette directive peut causer des blessures graves, un incendie, une décharge électrique ou la mort.
- Pour obtenir un rendement optimal, branchez l'appareil sur une prise électrique qui lui est réservée. Cela permet d'éviter de surcharger les circuits de câblage de la maison; une telle surcharge pourrait provoquer un incendie en raison de la surchauffe des fils.
- Au besoin, installez une nouvelle fiche à 3 broches (mise à la terre) certifiée UL ayant une tension nominale égale ou supérieure à celle du circuit de la prise. N'utilisez pas une rallonge de plus de 91,4 cm (3 pi) de long. Le non-respect de ces avertissements peut causer des blessures graves, un incendie, une décharge électrique ou la mort.

Essai de la laveuse

Vérifiez si la laveuse est installée correctement et menez un test de fonctionnement.

- 1 Chargez la laveuse avec six serviettes de bain épaisses (environ six livres).
- 2 Appuyez sur le bouton **Marche/arrêt**.
- 3 Sélectionnez un cycle **Rinse+Spin (Rinçage et essorage)**.
- 4 Appuyez sur le bouton **Démarrer/pause** pour démarrer le cycle de lavage.
- 5 Assurez-vous que l'eau est acheminée, que la laveuse ne bascule pas et ne vibre pas de

façon excessive, et que l'évacuation se fait bien pendant le cycle d'essorage.

REMARQUE

- S'il y a une fuite d'eau lorsque l'eau est acheminée, reportez-vous à la partie **Raccordement des tuyaux d'arrivée d'eau** afin de les raccorder correctement.
 - Si la laveuse bascule ou vibre de façon excessive, consultez la section **Mise au niveau de la laveuse** pour la remettre au niveau.
 - Si l'évacuation d'eau ne se fait pas bien, consultez la section **Raccordement du tuyau de vidange** pour installer le tuyau correctement.
-

FONCTIONNEMENT

Avant l'utilisation

AVERTISSEMENT

- Pour réduire le risque d'incendie, de décharge électrique ou de blessures, lisez les DIRECTIVES DE SÉCURITÉ avant d'utiliser cet appareil.
-

Aperçu du fonctionnement

- 1** Triez les articles et chargez la laveuse.
 - Triez les articles par type de tissu, niveau de saleté, couleur et poids, au besoin. Ouvrez la porte et insérez les articles dans la laveuse.
 - Si vous utilisez des capsules de détergent à usage unique, placez la capsule dans le tambour avant de charger la lessive.
- 2** Ajoutez les produits de nettoyage.
 - Ajoutez la quantité appropriée de détergent à haute efficacité (HE) dans le distributeur de détergent.
 - Si vous le désirez, ajoutez du javellisant ou de l'assouplissant dans les compartiments appropriés du tiroir du distributeur.
 - Ne mettez pas de capsules de détergent en poudre ou liquide dans le distributeur.
- 3** Mettez la laveuse en marche.
 - Appuyez sur le bouton **Marche/arrêt** pour allumer la laveuse.
- 4** Sélectionnez un cycle.
 - Tournez le bouton de sélection des cycles ou appuyez sur les boutons de cycle à plusieurs reprises jusqu'à ce que le cycle désiré soit sélectionné.
 - La température de lavage préréglée, la vitesse d'essorage, le niveau de saleté et les réglages d'options pour ce cycle s'affichent.
 - Le cycle **Normal** doit être sélectionné pour pouvoir modifier ses réglages par défaut.
 - Appuyer sur le bouton **Démarrer/pause** sans sélectionner un cycle lance immédiatement le cycle **Normal** avec les réglages par défaut.
- 5** Ajustez les réglages.
 - Les réglages par défaut du cycle sélectionné peuvent maintenant être modifiés, au besoin, à l'aide des boutons d'options et de modification des cycles.
 - Toutes les modifications et les options ne sont pas disponibles pour certains cycles. Un carillon différent retentira et le voyant à DEL ne s'allumera pas si la sélection n'est pas permise.
- 6** Démarrez le cycle.
 - Appuyez sur le bouton **Démarrer/pause** pour lancer le cycle. La porte se verrouille et la laveuse va s'agiter brièvement sans eau pour mesurer le poids de la brassée.
 - Si le bouton **Démarrer/pause** n'est pas enfoncé dans un certain délai, la laveuse s'arrête et les réglages sont perdus.

7 Fin du cycle.

- Une mélodie annonce que le cycle est terminé. Retirez immédiatement les vêtements de la laveuse pour réduire la formation de plis.
- Vérifiez les pourtours du joint de la porte quand vous enlevez la brassée et retirez les petits articles qui y seraient restés coincés.

REMARQUE

- La laveuse fait tourner la lessive de façon à ce que l'appareil consomme moins d'eau tout en imbibant complètement vos articles. Il est normal de ne pas voir l'eau pendant le cycle de lavage.
- Si la température ou le niveau d'eau à l'intérieur de la laveuse est trop élevé, la porte ne se déverrouillera pas lorsque vous appuierez sur le bouton **Démarrer/pause**, et la fonctionnalité **Add Item (Ajouter vêtements)** ne sera pas disponible (sur les modèles applicables). Pour arrêter un cycle et évacuer l'eau complètement, mettez l'appareil hors tension, puis sous tension, et appuyez sur **Rinse+Spin (Rinçage et essorage)**.

Tri des articles

⚠ MISE EN GARDE

- Les vêtements ou les articles imperméables ou résistants à l'eau doivent être lavés à l'aide du cycle **Bedding** seulement (p. ex. les vêtements résistants à l'eau, les housses de matelas, les vêtements de plein air, les tapis en plastique, etc.). Le non-respect de cette consigne pourrait entraîner des blessures ou des dommages à la laveuse, aux vêtements, aux murs, au plancher et aux objets à proximité en raison de vibrations anormales.
- Retirez le rembourrage des oreillers et des coussins avant de laver les housses. Le non-respect de cette consigne peut provoquer des vibrations excessives, ce qui peut endommager la laveuse, les vêtements, les objets à proximité, les murs et le plancher.

Regrouper les articles similaires

Pour obtenir des résultats de lavage optimaux et réduire le risque d'endommager un article, triez bien vos articles pour faire des brassées d'articles semblables.

Mélanger des articles avec différents types de tissus et différents niveaux de saleté peut causer un mauvais rendement de lavage, le transfert de couleurs, la décoloration, l'endommagement des tissus et le peluchage. Les tissus devraient être triés en groupes comme cela est décrit ci-dessous.

Couleurs

Triez les articles par couleur. Lavez les vêtements foncés ensemble, dans une brassée séparée des vêtements pâles ou des articles blancs. Mélanger des articles foncés avec des articles pâles peut causer un transfert de couleurs ou la décoloration des vêtements pâles.

Niveau de saleté

Lavez les vêtements très sales ensemble. Mélanger des vêtements peu sales avec des vêtements très sales peut causer de mauvais résultats de lavage pour les vêtements peu sales.

Types de tissus

Les articles délicats ne devraient pas être mêlés avec des types de tissus lourds ou robustes. Laver des tissus lourds avec des articles délicats peut causer de mauvais résultats de lavage pour les tissus lourds et peut endommager les articles délicats.

Peluchage











Certains tissus attirent les peluches, alors que d'autres produisent des peluches durant le processus de lavage. Évitez de mélanger les tissus qui attirent les peluches avec ceux qui en produisent dans une même brassée. Mélanger ces tissus entraînera du boulochage et l'accumulation de peluches sur les collecteurs de peluches. (Par exemple, un chandail tricoté attire la peluche; les serviettes éponges en produisent.)

Comment trier les vêtements

Par couleur	Par saleté	Par tissu	Par peluchage
Blancs	Très sales	Délicats	Producteurs de peluches
Pâles	Normal	Sans repassage	Collecteurs de peluches
Foncés	Peu sales	Robustes	

Étiquettes d'entretien des tissus

Beaucoup de vêtements comportent une étiquette d'entretien des tissus. Consultez le tableau ci-dessous pour choisir le cycle et les options en fonction des recommandations du fabricant de vos vêtements.

Catégorie	Étiquette	Directives
 Lavage		Lavage à la main
		Lavage à la machine, cycle normal
		Réglage pour tissus infroissables/résistants au froissement (doté d'une étape de refroidissement ou de vaporisation froide avant l'essorage lent)
		Réglage pour tissus doux/délicats (agitation lente ou temps de lavage réduit)
		Ne pas laver
		Ne pas tordre
Température de l'eau	...	Chaude
	..	Tiède
	.	Froide
 Symboles pour javellisant		Tout javellisant (au besoin)
		Seulement un javellisant non chloré (au besoin)
		Ne pas utiliser de javellisant

Chargement de la laveuse

⚠ MISE EN GARDE

- Les vêtements ou les articles imperméables ou résistants à l'eau doivent être lavés à l'aide du cycle **Bedding** seulement (p. ex. les vêtements résistants à l'eau, les housses de matelas, les vêtements de plein air, les tapis en plastique, etc.). Le non-respect de cette consigne pourrait

entraîner des blessures ou des dommages à la laveuse, aux vêtements, aux murs, au plancher et aux objets à proximité en raison de vibrations anormales.

Conseils généraux

- Vérifiez et videz les poches. Les trombones, les pièces de monnaie, les allumettes, etc., peuvent endommager les vêtements et la laveuse.

- Fermez les fermetures à glissière et les agrafes, et attachez les cordons pour les empêcher de s'accrocher ou de s'emmêler aux autres vêtements.
- Prétraitez les taches tenaces pour obtenir de meilleurs résultats.
- Brossez les vêtements pour enlever l'excès de saleté, de poussière et de cheveux avant de les laver. La saleté ou le sable en excès risquent d'user les autres tissus et de causer un lavage de mauvaise qualité.
- Pour de meilleurs résultats, chargez les vêtements dans l'appareil comme illustré.

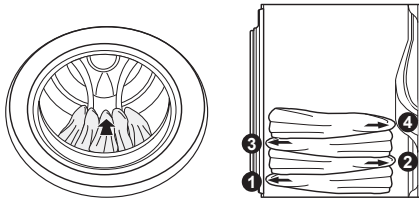

- N'appuyez pas sur les articles lorsque vous les déposez dans le tambour.
- Chargez les vêtements grossièrement et ne surchargez pas le tambour. Les vêtements nécessitent de l'espace pour circuler pour assurer leur propreté.
- Combinez les grands et petits articles dans le tambour. Mettez les grands articles en premier. Les grands articles ne doivent pas représenter plus de la moitié de la brassée totale.
- La laveuse peut être complètement remplie, mais les articles ne doivent pas être compressés dans le tambour. La porte de la laveuse doit pouvoir être fermée facilement.
- La laveuse ne peut se remplir d'eau ni fonctionner si la porte est ouverte.

Articles volumineux

- Lavez les articles épais et volumineux individuellement. Les couvertures épaisses, les duvets, les couvre-lits ou les lits des animaux risquent de s'emmêler ou de déséquilibrer la brassée si on les combine avec d'autres articles.

Petits articles

- Ne lavez pas un petit article seul. Ajoutez quelques articles semblables à la brassée pour éviter que la brassée soit déséquilibrée.
- Lavez les petits articles légers dans un sac-filet. Les petits articles peuvent se coincer dans la

roue de pompe se trouvant au fond du tambour, et les crochets de soutien-gorge peuvent s'accrocher à d'autres vêtements ou au tambour.

Ajout de produits de nettoyage

À propos de l'utilisation du détergent

Cette laveuse est conçue pour être utilisée uniquement avec des détergents à haute efficacité (HE).



- Les détergents HE produisent moins de mousse, se dissolvent plus efficacement pour améliorer le rendement de lavage et de rinçage, et aident à garder l'intérieur de la laveuse propre. L'utilisation d'un détergent qui n'est pas HE peut causer un excès de mousse et un rendement insatisfaisant pouvant provoquer des codes d'erreur, entraîner l'échec d'un cycle et endommager la laveuse.
- Les détergents identifiés comme étant compatibles avec la haute efficacité ne donneront peut-être pas des résultats optimaux.
- Pour obtenir un rendement de lavage satisfaisant, mesurez toujours le détergent avec l'outil de mesure fourni par le fabricant du détergent. Pour une brassée moyenne, utilisez moins de la moitié de la quantité maximale recommandée. Utilisez moins de détergent avec de l'eau douce, des vêtements peu sales ou des petites brassées.
- Faites très attention lors de la mesure des détergents concentrés 2X et 3X puisque même une petite quantité supplémentaire peut entraîner des problèmes.
- N'utilisez jamais plus que la quantité maximale de détergent recommandée par le fabricant. L'utilisation d'une trop grande quantité de détergent peut entraîner une production excessive de mousse, un mauvais rinçage, une accumulation de détergent dans les vêtements et une accumulation de résidus qui peuvent contribuer aux odeurs dans l'appareil.
- N'utilisez pas plus d'une capsule de détergent dans la laveuse. L'utilisation d'une trop grande quantité de détergent peut causer la formation d'une quantité excessive de mousse ainsi qu'un rendement insatisfaisant. Diminuez la quantité de détergent ou ajoutez un rinçage

supplémentaire si des résidus de détergent se retrouvent sur les tissus. Pour ajouter un rinçage supplémentaire, sélectionnez l'option **Extra Rinse (Rinçage supplémentaire)**.

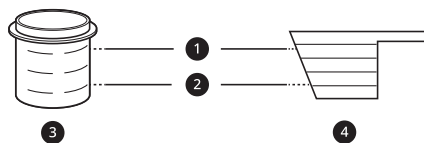

- ❶ Ligne de capacité maximale
- ❷ Ligne de remplissage moyen
- ❸ Détergent liquide
- ❹ Détergent en poudre

Capsules de détergent à usage unique

Déposez la capsule de détergent en poudre ou liquide dans le tambour avant d'y placer les vêtements. Ne mettez pas de capsules dans le distributeur.

Utilisation du distributeur

Pour ajouter des produits de nettoyage au distributeur automatique :

- 1 Ouvrez le tiroir du distributeur.
- 2 Versez les produits pour la lessive dans les compartiments appropriés.
 - Suivez les recommandations du fabricant lors de l'ajout de produits de nettoyage.

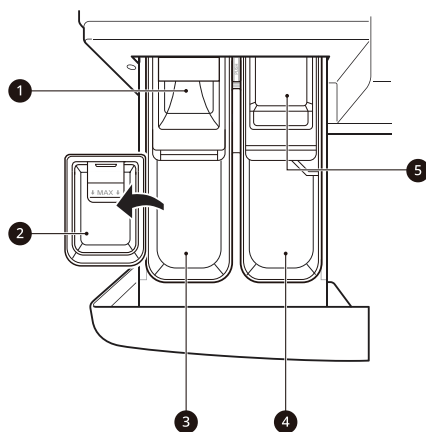

- ❶ Compartiment de détergent pour pré-lavage (sur certains modèles)

- ❷ Tasse de détergent liquide
- ❸ Compartiment principal de détergent
- ❹ Compartiment pour l'assouplissant liquide
- ❺ Compartiment de javellisant au chlore liquide

- 3 Fermez doucement le tiroir du distributeur de détergent avant de commencer le cycle.
 - Le fait de fermer abruptement le tiroir peut causer le renversement du détergent dans un autre compartiment ou le versement dans le tambour plus tôt que prévu.
 - Veillez à ne pas vous coincer la main dans le tiroir lorsque vous le fermez.
 - Il est normal qu'une petite quantité d'eau demeure dans les compartiments du distributeur à la fin du cycle.

⚠ MISE EN GARDE

- Ne placez pas et ne rangez pas de produits de lessive, comme du détergent, du javellisant ou de l'assouplissant liquide sur le dessus de votre laveuse. Ces produits peuvent endommager le fini et les commandes de la laveuse.

Compartiment de détergent pour pré-lavage

Mettez le détergent liquide ou en poudre dans ce compartiment quand vous utilisez l'option **Pre-wash (Pré-lavage)**. Utilisez toujours un détergent HE (haute efficacité) avec votre laveuse.

- Quand vous utilisez l'option **Pre-wash (Pré-lavage)**, le détergent liquide pour le lavage principal doit être placé dans le contenant à détergent liquide, fourni en tant qu'accessoire, dans le distributeur de lavage principal (s'il y a lieu) pour empêcher qu'il soit distribué avec le détergent de pré-lavage.
- La quantité de détergent utilisé pour l'option **Pre-wash (Pré-lavage)** représente la moitié de la quantité recommandée pour le cycle de lavage principal. Par exemple, si le cycle de lavage principal nécessite une mesure de détergent, il faut utiliser la moitié de la mesure pour l'option **Pre-wash (Pré-lavage)**.

Compartiment principal de détergent

Ce compartiment contient le détergent à lessive utilisé pour le cycle de lavage principal. Le détergent placé dans ce compartiment peut être liquide ou en poudre.

- Le détergent est ajouté à la brassée au début du cycle. Utilisez toujours un détergent HE (haute efficacité) avec votre laveuse.
- Ne dépassez pas la ligne de remplissage maximal. Utiliser trop de détergent peut entraîner une accumulation de détergent dans les vêtements et la laveuse.
- Un javellisant sûr pour les couleurs, liquide ou en poudre, peut être ajouté dans le compartiment de lavage principal avec le détergent de même type. N'utilisez pas à la fois des liquides et de la poudre.
- Si le distributeur contient un contenant à détergent liquide et une insertion :
 - Veillez à ce qu'ils soient en place lorsque vous utilisez du détergent liquide.
 - Veillez à les retirer lorsque vous utilisez du détergent en poudre. Le détergent en poudre ne sera pas distribué si le contenant à détergent liquide et l'insertion sont en place.
- L'utilisation d'un détergent qui ne se dissout pas rapidement ou d'un détergent de grande viscosité laissera des résidus qui vont obstruer le distributeur.

Compartiment à javellisant liquide

Ce compartiment contient le javellisant liquide, qui est distribué automatiquement au moment adéquat durant le cycle de lavage. Le distributeur est activé deux fois pour assurer que le javellisant a été entièrement distribué. Le liquide qui reste dans le distributeur à la fin du cycle n'est que de l'eau, pas du javellisant.

AVERTISSEMENT

- Ne mélangez PAS de javellisant chloré avec de l'ammoniac ou des agents acides comme le vinaigre ou un produit pour enlever la rouille ou antitartre. Mélanger des produits chimiques comme ces derniers peut produire un gaz létal, entraînant de graves blessures ou la mort.

REMARQUE

- Ne mettez pas de javellisant en poudre dans ce compartiment. Le compartiment à javellisant est conçu pour distribuer un javellisant liquide seulement. Un javellisant sûr pour les couleurs, liquide ou en poudre, ne sera pas distribué correctement.
- Respectez toujours les recommandations du fabricant lorsque vous ajoutez du javellisant. N'ajoutez jamais plus d'une tasse et ne dépassez jamais la ligne de remplissage maximal puisque cela ferait en sorte que le javellisant soit

distribué immédiatement, ce qui endommagerait les tissus. Utiliser trop de javellisant peut également endommager les tissus.

- Ne versez jamais de javellisant chloré non dilué directement dans la brassée ou dans le tambour. Cela endommagerait les tissus.
- N'utilisez pas de javellisant sûr pour les couleurs ou de produits à base d'oxygène dans le même cycle avec un javellisant chloré liquide.

Compartiment pour l'assouplissant

Ce compartiment contient l'assouplissant liquide, qui est automatiquement distribué pendant le cycle final de rinçage. Vous pouvez utiliser de l'assouplissant en poudre ou liquide.

- Ne dépassez pas la ligne de remplissage maximal. Utiliser trop d'assouplissant peut tacher les vêtements ou causer une accumulation sur les tissus ou dans la laveuse.
- Diluez les assouplissants concentrés avec de l'eau tiède.
- Ne versez jamais d'assouplissant directement dans la brassée ou dans le tambour.

Panneau de commande

Caractéristiques du panneau de commande

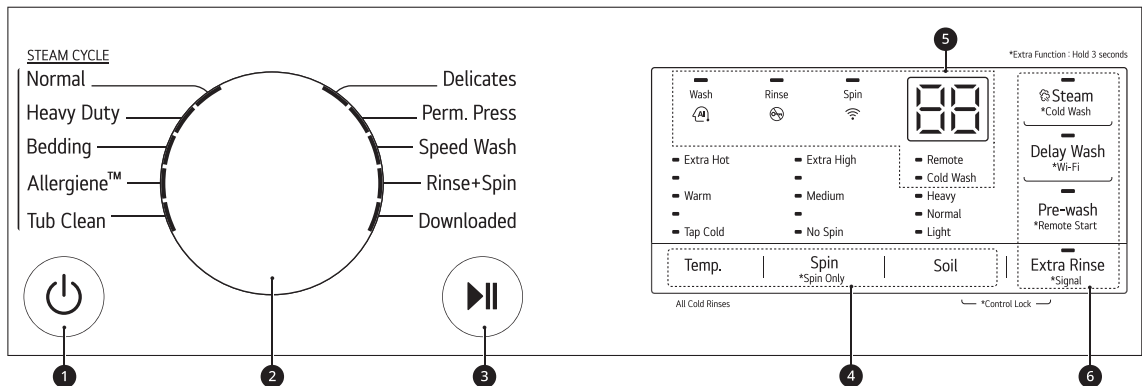

1 Bouton Marche/arrêt

- Appuyez sur ce bouton pour allumer ou éteindre la laveuse.
- Le fait d'appuyer sur ce bouton pendant un cycle annulera ce cycle, et les réglages de la brassée seront perdus.
- La porte se déverrouillera après une courte pause.

REMARQUE

- S'il reste de l'eau dans le tambour après l'arrêt de la laveuse, elle sera évacuée après quelques minutes. La laveuse peut être redémarrée à tout moment avant le début du drainage. Cependant, une fois que l'eau commence à être évacuée, toutes les fonctionnalités seront désactivées jusqu'à ce que l'eau soit complètement vidée et que la laveuse s'arrête.

2 Bouton de sélection de cycle

- Tournez ce bouton pour sélectionner le cycle désiré.
- Une fois que le cycle désiré a été sélectionné, les préreglages standards s'affichent. Ces réglages peuvent être ajustés à l'aide des **boutons de modification du cycle** à tout moment avant le début du cycle.

3 Bouton Démarrer/pause

- Appuyez sur ce bouton pour démarrer le cycle sélectionné.
- Si la laveuse est en marche, utilisez ce bouton pour interrompre le cycle sans perdre les réglages actuels.

REMARQUE

- Si vous n'appuyez pas sur le bouton **Démarrer/pause** pour lancer le cycle sélectionné, la laveuse s'éteint automatiquement après un certain délai et tous les réglages du cycle sont perdus. L'eau restante dans le tambour sera évacuée.

4 Boutons de modification des cycles

- Utilisez ces boutons pour régler la température de lavage, la vitesse d'essorage et le niveau de saleté pour le cycle sélectionné.
- Les paramètres sélectionnés sont affichés à l'écran.
- Le bouton de cette option permet de sélectionner d'autres paramètres.

5 Afficheur de temps et d'état

6 Boutons d'options et de fonctions supplémentaires

- Ces boutons vous permettent de sélectionner des options de cycle supplémentaires. Certains boutons vous permettent également d'activer des fonctions spéciales en appuyant sur le bouton et en le maintenant enfoncé pendant **trois secondes**.

Afficheur de temps et d'état

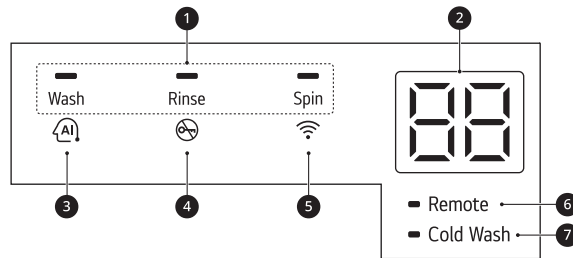

1 Indicateurs d'état du cycle

- Ces voyants à DEL clignotent lorsqu'un cycle est sélectionné afin d'indiquer quelles étapes seront effectuées.
- Lorsqu'un cycle est en cours, le voyant à DEL de l'étape active clignote et les voyants à DEL des autres étapes restent complètement allumés. Lorsqu'une étape est terminée, le voyant à DEL s'éteint. Si un cycle est mis en pause, le voyant à DEL de l'étape active cesse de clignoter.

2 Temps restant estimé

- Lorsqu'un cycle est sélectionné, la durée par défaut de ce cycle est affichée. Cette durée change si le cycle est modifié ou si des options sont sélectionnées.
- Si --- apparaît sur l'affichage, alors le temps sera affiché après que la fonction de détection de charge ait détecté la taille de la brassée.
- La durée affichée n'est qu'une estimation. Cette durée est basée sur des conditions normales de fonctionnement. Plusieurs facteurs externes (la taille de la brassée, la température ambiante, la température de l'eau entrante, etc.) peuvent affecter la durée réelle.

REMARQUE

- Une fois le bouton **Démarrer/pause** enfoncé, la laveuse mesurera la taille de la brassée. La durée estimée peut changer lorsque la brassée aura été mesurée.
- Si la fonctionnalité de **Delay Wash (Lavage différé)** est sélectionnée, un compte à rebours indique le temps restant avant que le cycle commence.

3 Indicateur DD IA

- La fonction **DD IA** fait tourner le tambour de façon appropriée lorsque la détection de la brassée est terminée.
- L'indicateur s'allume dans les situations suivantes :
 - Lorsque le cycle **Normal** est sélectionné et activé, sauf lorsque le niveau de saleté **Heavy (Très sale)** est sélectionné.

4 Témoin de verrouillage de la porte

- Cet indicateur s'allume lorsque le cycle commence et que la porte est verrouillée.
- Le témoin lumineux reste allumé jusqu'à ce que le cycle soit suspendu, arrêté ou terminé.

5 Indicateur Wi-Fi

- Ce témoin est allumé lorsque le produit est connecté à un réseau Wi-Fi domestique.

6 Indicateur de démarrage à distance

26 FONCTIONNEMENT

- Cet indicateur s'allume lorsque la fonction **Remote Start (Démarrage à distance)** est activée.

⑦ Indicateur de Lavage à l'eau froide

- Cet indicateur s'allume lorsque la fonction **Cold Wash (Lavage à l'eau froide)** est activée.

Cycles de lavage

Les cycles de lavage sont conçus pour différents types de brassées. Sélectionnez le cycle qui correspond le mieux au contenu de la brassée afin d'obtenir des résultats de lavage et un entretien des tissus optimaux. Pour obtenir des résultats optimaux, consultez la section **Tri des articles** et respectez les étiquettes d'entretien des tissus qui se trouvent sur vos articles. Pour obtenir un guide sur les symboles d'entretien des tissus, consultez la section **Tri des articles**.

Guide sur les cycles

Tournez le bouton ou appuyez sur le bouton pour sélectionner le cycle souhaité. Lorsque vous sélectionnez un cycle de lavage, le témoin correspondant au cycle s'allume.

REMARQUE

- Chaque fois que les poids des brassées sont mentionnés, considérez **que 0,45 kg (1 lb)** représente environ le poids d'une serviette de bain épaisse (sèche).

• Extra Hot	• Extra High
• Hot	• High
• Warm	• Medium
• Cold	• Low
• Tap Cold	• No Spin
Temp.	Spin

- L'indicateur de température s'allume lorsque l'une des fonctionnalités **Tap Cold (Eau froide du robinet), Cold (Eau froide), Warm (Tiède), Hot (Chaude)** ou **Extra Hot (Extra chaude)** est sélectionnée.
- L'indicateur d'essorage s'allume lorsque l'une des fonctionnalités **No Spin (Aucun essorage), Low (Faible), Medium (Moyenne), High (Élevée)** ou **Extra High (Très élevée)** est sélectionnée.

Cycle	Normal	
Description	Utilisez ce cycle pour laver tous les articles normaux tels que le coton, le lin, les chemises, les jeans et les brassées mixtes, à l'exception des tissus délicats comme la laine ou la soie. <ul style="list-style-type: none"> Si vous appuyez sur le bouton Démarrer/pause sans sélectionner un cycle, le cycle Normal commencera immédiatement en utilisant les réglages par défaut. 	
Température de lavage	Par défaut : Warm (Tiède)	Disponibilité : Toutes les températures
Vitesse d'essorage	Par défaut : High (Élevée)	Disponibilité : Toutes les températures
Niveau de saleté	Par défaut : Normal	Disponibilité : Toutes les températures

Cycle	Heavy Duty (Haut rendement)	
Description	Convient au lavage des articles très souillés, tels que les tissus en coton, en utilisant des mouvements de lavage plus puissants. <ul style="list-style-type: none"> Lors du lavage de brassées importantes, il y aura de brèves périodes de 2 minutes ou plus sans agitation. Ces périodes de trempage font partie du fonctionnement du cycle et sont normales. 	
Température de lavage	Par défaut : Warm (Tiède)	Disponibilité : Toutes les températures
Vitesse d'essorage	Par défaut : Extra High (Très élevée)	Disponibilité : Toutes les températures
Niveau de saleté	Par défaut : Heavy (Très sale)	Disponibilité : Toutes les températures

Cycle	Bedding (Literie)	
Description	Convient au lavage des couvertures ou des articles volumineux absorbant difficilement l'eau, tels que les oreillers, les couvertures, les couettes, les draps ou la literie pour animaux de compagnie. <ul style="list-style-type: none"> • N'utilisez pas ce cycle pour laver une brassée mixte de literie et d'articles autres que de la literie. • Ne mélangez pas des articles volumineux avec des vêtements plus petits. • Ne lavez pas d'articles très volumineux. Si les articles volumineux et encombrants ne rentrent pas facilement dans la cuve, ils pourraient ne pas se déplacer correctement pendant le lavage. 	
Température de lavage	Par défaut : Warm (Tiède)	Disponibilité : Hot (Chaude), Warm (Tiède), Cold (Eau froide), Tap Cold (Eau froide du robinet)
Vitesse d'essorage	Par défaut : Medium (Moyenne)	Disponibilité : Medium (Moyenne), Low (Faible), No Spin (Aucun essorage)
Niveau de saleté	Par défaut : Normal	Disponibilité : Toutes les températures

Cycle	Allergiene ^{MC}	
Description	Ce cycle puissant et à température élevée est conçu spécialement pour réduire certains allergènes. <p>REMARQUE</p> <ul style="list-style-type: none"> • La sélection de ce cycle ajoute automatiquement de la vapeur au cycle de lavage. • Ce cycle peut réduire considérablement la présence d'allergènes dans la literie et les vêtements. • Ce cycle aide à réduire les populations d'acariens et les allergènes. En raison de l'énergie et des températures élevées utilisées, ce cycle n'est pas recommandé pour la laine, la soie, le cuir ou tout autre article délicat sensible à la température. 	
Vitesse d'essorage	Par défaut : High (Élevée)	Disponibilité : Toutes les températures

Cycle	Tub Clean (Nettoyage de la cuve)
Description	Il s'agit d'un cycle spécial conçu pour nettoyer l'intérieur de la laveuse.

Cycle	Delicates (Déliçats)	
Description	Convient au lavage des chemises ou chemisiers, des bas de nylon, de la lingerie ou des vêtements transparents et en dentelle qui peuvent facilement être endommagés (moins de 8 lb [3,63 kg]).	
Température de lavage	Par défaut : Cold (Eau froide)	Disponibilité : Warm (Tiède), Cold (Eau froide), Tap Cold (Eau froide du robinet)
Vitesse d'essorage	Par défaut : Medium (Moyenne)	Disponibilité : Medium (Moyenne), Low (Faible), No Spin (Aucun essorage)
Niveau de saleté	Par défaut : Normal	Disponibilité : Toutes les températures

Cycle	Perm. Press (Tissus infroissables)	
Description	Utilisez ce cycle pour réduire le froissement lors du lavage de nappes ou de vêtements « infroissables ».	
Température de lavage	Par défaut : Warm (Tiède)	Disponibilité : Hot (Chaude), Warm (Tiède), Cold (Eau froide), Tap Cold (Eau froide du robinet)
Vitesse d'essorage	Par défaut : Medium (Moyenne)	Disponibilité : High (Élevée), Medium (Moyenne), Low (Faible), No Spin (Aucun essorage)
Niveau de saleté	Par défaut : Normal	Disponibilité : Toutes les températures

Cycle	Speed Wash (Lavage rapide)	
Description	Le cycle de lavage rapide permet de laver rapidement des vêtements peu sales et les petites brassées. Pour obtenir de meilleurs résultats de lavage et de rinçage, lavez de petites brassées de deux ou trois articles légèrement sales (moins de 3 lb [1,36 kg]). <ul style="list-style-type: none"> • Pour ce cycle, utilisez très peu de détergent. Pour ajouter un rinçage supplémentaire, utilisez l'option Extra Rinse (Rinçage supplémentaire). 	
Température de lavage	Par défaut : Hot (Chaude)	Disponibilité : Hot (Chaude), Warm (Tiède), Cold (Eau froide), Tap Cold (Eau froide du robinet)
Vitesse d'essorage	Par défaut : Extra High (Très élevée)	Disponibilité : Toutes les températures
Niveau de saleté	Par défaut : Light (Peu sale)	Disponibilité : Toutes les températures

Cycle	Rinse+Spin (Rinçage et essorage)	
Description	Sélectionnez ce cycle pour rincer et essorer une brassée séparément d'un cycle ordinaire. <ul style="list-style-type: none"> • Cela peut être utile pour empêcher les nouvelles taches d'intégrer les tissus. • Vous pouvez changer la vitesse d'essorage en appuyant plusieurs fois sur le bouton Spin (Vitesse d'essorage) jusqu'à ce que la vitesse souhaitée soit sélectionnée. 	

Cycle	Downloaded (Small Load) (Cycle téléchargé (Petite brassée))	
Description	Vous pouvez utiliser un téléphone intelligent pour télécharger un cycle particulier à cette position de cycle. <ul style="list-style-type: none"> • Le cycle par défaut est Small Load (Petite brassée) (petite brassée), qui est utilisé pour les brassées normalement sales composées de quelques articles seulement. Ce cycle peut également être téléchargé. • Reportez-vous à l'application LG ThinQ pour découvrir les cycles qu'il est possible de télécharger. 	
Température de lavage	Par défaut : Warm (Tiède)	Disponibilité : Hot (Chaude), Warm (Tiède), Cold (Eau froide), Tap Cold (Eau froide du robinet)
Vitesse d'essorage	Par défaut : High (Élevée)	Disponibilité : Toutes les températures

Cycle	Downloaded (Small Load) (Cycle téléchargé (Petite brassée))	
Niveau de saleté	Par défaut : Normal	Disponibilité : Toutes les températures

Options disponibles

† Cette option est automatiquement incluse dans le cycle et ne peut pas être désélectionnée.

REMARQUE

- **Delay Wash (Lavage différé)** (rinçage supplémentaire) et **Extra Rinse (Rinçage supplémentaire)** (programme personnalisé) peuvent être sélectionnées pour chaque cycle de ce tableau.
- Vous ne pouvez pas sélectionner les options **Steam (Vapeur)** et **Cold Wash (Lavage à l'eau froide)** en même temps.

Cycle	Steam (Vapeur)	Cold Wash (Lavage à l'eau froide)	Pre-wash (Pré lavage)
Normal	●	●	●
Heavy Duty (Haut rendement)	●	●	●
Bedding (Literie)	●	●	●
Allergiene ^{MC}	●†		
Delicates (Déliçats)		●	●
Perm. Press (Tissus infroissables)		●	●
Speed Wash (Lavage rapide)		●	
Rinse+Spin (Rinçage et essorage)			
Downloaded (Cycle téléchargé) Par défaut:Small Load (Petite brassée)		●	●

Modificateurs de cycle

À propos des boutons de modification

Chaque cycle possède des réglages par défaut qui sont sélectionnés automatiquement. Vous pouvez aussi personnaliser ces réglages en utilisant les boutons de modification des cycles.

- Appuyez à plusieurs reprises sur le bouton de la modification souhaitée jusqu'à ce que le voyant lumineux correspondant au réglage désiré s'allume.
- La laveuse ajuste automatiquement le niveau d'eau au type de brassée et à la taille de celle-ci afin d'offrir de meilleurs résultats et une efficacité maximale.
- Il s'agit d'une laveuse à haute efficacité, et les niveaux d'eau peuvent être beaucoup plus bas que prévu. Ceci est normal et les résultats de nettoyage et de rinçage ne seront pas compromis.

• Extra Hot	• Extra High	• Remote
•	•	• Cold Wash
• Warm	• Medium	• Heavy
•	•	• Normal
• Tap Cold	• No Spin	• Light
Temp.	Spin *Spin Only	Soil

REMARQUE

- Le voyant à DEL situé à côté du réglage s'allume lorsque le réglage est sélectionné.
- Dans le but de protéger vos vêtements, les cycles n'offrent pas tous les mêmes réglages (température de lavage, vitesse d'essorage, niveau de saleté et options).
- Si un réglage sélectionné n'est pas autorisé pour le cycle choisi, un carillon retentira deux fois et le voyant à DEL ne s'allumera pas.
- Suivez les instructions des étiquettes d'entretien des tissus sur les vêtements pour obtenir des résultats optimaux.

Temp. (Température)

Assurez-vous que la température de lavage est appropriée pour le type de brassée que vous désirez laver.

- Appuyez sur le bouton **Temp. (Température)** à plusieurs reprises pour sélectionner la combinaison de température de lavage et de rinçage pour le cycle sélectionné.

- Tous les rinçages se font à l'eau froide.
- Les rinçages à l'eau froide consomment moins d'énergie. La température actuelle du rinçage à l'eau froide dépend de la température de l'eau froide qui sort du robinet.
- Votre laveuse est dotée d'un élément chauffant pour augmenter la température de l'eau chaude pour les réglages **Extra Hot (Extra chaude)**. Cela permet d'améliorer le rendement du lavage avec les réglages normaux du chauffe-eau.

Spin (Vitesse d'essorage)

Des vitesses d'essorage élevées extraient plus d'eau des vêtements, ce qui réduit le temps de séchage et économise l'énergie.

- Appuyez sur le bouton **Spin (Vitesse d'essorage)** à plusieurs reprises jusqu'à ce que la vitesse souhaitée soit sélectionnée.
- Certains tissus, comme les tissus délicats, exigent une vitesse d'essorage lente.

Spin Only (Essorage seulement)

Cette option essore la brassée sans passer par le cycle de lavage et de rinçage, ce qui est utile pour essorer des articles lavés à la main.

- Appuyez sur le bouton **Spin (Vitesse d'essorage)** et maintenez-le enfoncé pendant trois secondes.

Soil (Saleté)

Choisir le réglage du niveau de saleté va modifier la durée du cycle ou les actions de lavage.

- Appuyez sur le bouton **Soil (Saleté)** jusqu'à ce que le niveau désiré de saleté soit sélectionné.
- Le réglage **Heavy (Très sale)** soil (saleté tenace) peut augmenter la durée du cycle. Le réglage **Light (Peu sale)** soil (saleté légère) peut réduire la durée du cycle.

Autres options et fonctionnalités

Votre laveuse dispose de plusieurs options de cycle supplémentaires afin de personnaliser les cycles et de répondre à vos besoins particuliers.

- Choisissez l'option souhaitée après avoir sélectionné le cycle et les réglages désirés.

REMARQUE

- Le voyant à DEL de l'option s'allume lorsque l'option est sélectionnée.
- Pour protéger vos vêtements, certaines options ne sont pas disponibles pour certains cycles.

REMARQUE

- Si une option sélectionnée n'est pas autorisée pour le cycle choisi, un carillon retentira deux fois et le voyant à DEL ne s'allumera pas.

Steam (Vapeur)

L'ajout de cette option à un cycle de lavage permet d'obtenir des performances de lavage supérieures. La vapeur donne aux tissus les avantages d'un lavage à l'eau très chaude.

- La vapeur peut ne pas être très visible pendant les cycles de vapeur. C'est normal. Trop de vapeur pourrait endommager les vêtements.
- N'utilisez pas de vapeur avec les tissus délicats comme la laine, la soie ou les tissus qui se décolorent facilement.

⚠ AVERTISSEMENT

- Ne touchez pas à la porte pendant les cycles de vapeur. La surface de la porte peut devenir très chaude et causer des brûlures graves. Avant d'ouvrir la porte, laissez la serrure de la porte se débloquer.
- N'essayez pas de forcer le mécanisme de verrouillage de la porte ou de mettre les mains à l'intérieur de la laveuse pendant un cycle de vapeur. La vapeur peut causer des brûlures sérieuses.

Utilisation de l'option de pré-lavage

Cette option ajoute un pré-lavage (d'une durée d'environ **15 à 17 minutes**) afin d'améliorer les performances de nettoyage des vêtements très sales ou tachés.

REMARQUE

- Si vous sélectionnez l'option **Pre-wash (Pré-lavage)** après avoir mis le détergent directement dans le tambour, le détergent risque d'être emporté, ce qui diminuera l'efficacité du lavage.

Remote Start (Démarrage à distance)

Utilisez un téléphone intelligent pour contrôler votre laveuse à distance.

- Pour obtenir plus de renseignements, consultez la section **FONCTIONS INTELLIGENTES** dans ce manuel.

Delay Wash (Lavage différé)

Lorsque vous avez sélectionné le cycle et les autres réglages, appuyez sur le bouton **Delay Wash (Lavage différé)** pour retarder le début du cycle de lavage.

- Chaque fois que vous appuyez sur ce bouton, vous retardez le lavage d'une heure; vous pouvez le retarder jusqu'à un maximum de 19 heures.
- Une fois le délai désiré réglé, appuyez sur le bouton **Démarrer/pause** pour démarrer le délai.

REMARQUE

- Si vous n'appuyez pas sur le bouton **Démarrer/pause** pour commencer la mise en marche différée, la laveuse s'arrêtera automatiquement après un certain temps et tous les réglages de cycle seront perdus.

Wi-Fi

Lorsque la laveuse est connectée à un réseau Wi-Fi domestique, l'icône  du panneau de commande est allumée.

- Pour connecter la laveuse à l'application **LG ThinQ**, appuyez sur le bouton **Delay Wash (Lavage différé)** et maintenez-le enfoncé pendant trois secondes.

Cold Wash (Lavage à l'eau froide)

Appuyez sur le bouton **Cold Wash (Lavage à l'eau froide)** (lavage à l'eau froide) pour économiser de l'énergie en utilisant de l'eau froide. Cela augmentera les temps de lavage et de rinçage pour maintenir les performances de lavage.

- L'ajout de cette option augmentera le temps de lavage de plusieurs minutes.
- Pour obtenir des résultats de lavage optimaux, sélectionnez cette option seulement lorsque vous lavez de petites brassées (moins de 8 livres).

Extra Rinse (Rinçage supplémentaire)

Cette option ajoute un rinçage supplémentaire au cycle sélectionné. Utilisez cette option pour veiller à ce que les tissus ne contiennent plus de résidus de détergent ou de javellisant.

- Appuyez sur le bouton **Extra Rinse (Rinçage supplémentaire)** pour ajouter d'autres rinçages au cycle.

Control Lock (Verrouillage des commandes)

Utilisez cette fonction pour désactiver les commandes. Elle peut empêcher les enfants de modifier les cycles ou de mettre cette laveuse en marche.

REMARQUE

- La fonctionnalité ne verrouille pas la porte.
- Une fois cette fonction réglée, tous les boutons sont verrouillés sauf le bouton **Marche/arrêt**.
- Lorsque les commandes sont verrouillées, **CL** et le temps restant s'affichent tour à tour pendant le cycle de lavage.
- Le fait de couper l'alimentation ne réinitialisera pas la fonctionnalité. Vous devez désactiver la fonctionnalité pour pouvoir accéder à d'autres fonctionnalités et options.

Verrouillage/déverrouillage du panneau de commande

- 1 Mettez l'appareil en marche.
 - 2 Appuyez sur les boutons **Soil (Saleté)** et **Extra Rinse (Rinçage supplémentaire)** maintenez-le enfoncé pendant trois secondes pour activer ou désactiver cette fonctionnalité.
- Lorsque la fonction est désactivée, un signal sonore se fait entendre et le temps restant du cycle en cours réapparaît dans l'affichage.

Signal (Tonalité)

La laveuse joue une mélodie à la fin du cycle de lavage. Les boutons produisent un son quand on appuie dessus. Utilisez ce bouton pour activer ou désactiver la mélodie et la tonalité des boutons.

- Pour activer ou désactiver la fonctionnalité, appuyez sur le bouton **Signal (Tonalité)**.

FONCTIONS INTELLIGENTES

Utilisation de l'application LG ThinQ

L'application **LG ThinQ** vous permet de communiquer avec l'appareil à l'aide d'un téléphone intelligent.

Caractéristiques de l'application LG ThinQ

- **Remote Start (Démarrage à distance)**
 - Cela vous permet de contrôler la laveuse à distance à l'aide de l'application **LG ThinQ**.
- **Downloaded (Cycle téléchargé)**
 - Cela vous permet de télécharger des cycles nouveaux et spéciaux qui ne sont pas inclus parmi les cycles de base de l'appareil.
- **Instructions pour le nettoyage de la cuve**
 - Cette fonctionnalité vous indique le nombre de cycles restant avant qu'il soit temps d'exécuter le cycle **Tub Clean (Nettoyage de la cuve)**.
- **Surveillance de la consommation d'énergie**
 - Cette fonctionnalité aide à effectuer le suivi de la consommation énergétique de la laveuse, qui varie en fonction des cycles et des options de lavage sélectionnés.
- **Smart Diagonisis^{MC}**
 - Cette fonction fournit des renseignements utiles pour diagnostiquer et résoudre les problèmes avec l'appareil en se basant sur le profil d'utilisation.
- **Notifications poussées**
 - Si le cycle est terminé ou que l'appareil éprouve des problèmes, vous recevrez un message automatisé.
- **Paramètres**
 - Cette fonctionnalité vous permet de régler diverses options de l'appareil et de l'application.

REMARQUE

- Si vous changez de routeur sans fil, de fournisseur de services Internet ou de mot de passe, supprimez l'appareil connecté de l'application **LG ThinQ**, puis connectez-le de nouveau.
- Cette information est à jour au moment de la publication. L'application est sujette à des modifications à des fins d'amélioration du

produit, et ce, sans que l'utilisateur en soit préalablement avisé.

Avant d'utiliser l'application LG ThinQ

- 1 Vérifiez la distance entre l'appareil et le routeur sans fil (réseau Wi-Fi).
 - S'il y a une trop grande distance entre l'appareil et le routeur sans fil, l'intensité du signal s'affaiblit. L'enregistrement peut prendre du temps ou l'installation peut échouer.
- 2 Désactivez les **Données mobiles** ou les **Données cellulaires** sur votre téléphone intelligent.

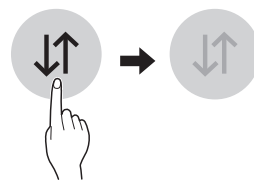

- 3 Connectez votre téléphone intelligent au routeur sans fil.

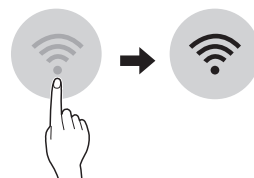

REMARQUE

- Pour vérifier l'état de la connexion Wi-Fi, assurez-vous que l'icône  qui se trouve sur le panneau de commande est allumée.
- L'appareil prend seulement en charge les réseaux Wi-Fi de 2,4 GHz. Pour vérifier la fréquence de votre réseau, contactez votre fournisseur de services Internet ou reportez-vous au manuel de votre routeur sans fil.
- **LG ThinQ** n'est pas responsable des problèmes de connexion au réseau ou des défauts, dysfonctionnements ou erreurs causés par la connexion au réseau.
- Si l'appareil a des difficultés à se connecter au réseau Wi-Fi, il est peut-être trop loin du routeur. Procurez-vous un répéteur Wi-Fi (rallonge de portée) pour améliorer la force du signal Wi-Fi.

- La connexion Wi-Fi peut ne pas se faire ou être interrompue à cause de l'environnement du réseau domestique.
- La connexion réseau peut ne pas fonctionner correctement selon le fournisseur de services Internet.
- L'environnement sans fil peut causer un ralentissement du fonctionnement du réseau sans fil.
- Si l'appareil ne peut pas être enregistré en raison de problèmes avec la transmission du signal sans fil, débranchez l'appareil et attendez environ une minute avant de réessayer.
- Si le pare-feu de votre routeur sans fil est activé, désactivez-le ou ajoutez-y une exception.
- Le nom du réseau sans fil (SSID) doit être une combinaison de lettres et de chiffres anglais. (N'utilisez pas de caractères spéciaux.)
- L'interface utilisateur (IU) du téléphone intelligent peut varier en fonction du système d'exploitation (SE) mobile et du fabricant.
- Si le protocole de sécurité du routeur est configuré sur **WEP**, la configuration du réseau peut échouer. Veuillez changer le protocole de sécurité (nous recommandons **WPA2**) et enregistrez le produit à nouveau.

Installation de l'application LG ThinQ

À partir d'un téléphone intelligent, cherchez l'application **LG ThinQ** dans la boutique Google Play ou l'App Store d'Apple. Suivez les directives pour télécharger et installer l'application.

Utilisation de l'appareil à distance

Remote Start (Démarrage à distance)

Utilisez un téléphone intelligent pour commander votre appareil à distance. Vous pouvez également suivre la progression du cycle et connaître le temps restant avant la fin de celui-ci.

Utiliser le Remote Start (Démarrage à distance)

- 1 Placez les articles dans le tambour et ajoutez du détergent dans le tiroir du distributeur de détergent.
 - Si vous le désirez, ajoutez du javellisant ou de l'assouplissant dans les compartiments appropriés du distributeur.

2 Appuyez sur le bouton **Marche/arrêt**.

3 Maintenez le bouton **Remote Start (Démarrage à distance)** enfoncé pendant trois secondes pour activer la fonction de commande à distance.

4 Démarrez un cycle à partir de l'application **LG ThinQ** sur votre téléphone intelligent.

REMARQUE

- Une fois cette fonction activée, vous pouvez seulement lancer un cycle de lavage à l'aide de l'application pour téléphone intelligent **LG ThinQ**. Si le cycle n'est pas démarré, l'appareil retardera le démarrage jusqu'à ce que le cycle soit désactivé à distance à partir de l'application ou que cette fonction soit désactivée.
- Si la porte est ouverte, vous ne pouvez pas démarrer un cycle de lavage à distance.

Désactivez Remote Start (Démarrage à distance) manuellement.

Lorsque la fonction est activée, maintenez le bouton **Remote Start (Démarrage à distance)** enfoncé pendant trois secondes.

Download Cycle (Téléchargement d'un cycle)

Téléchargez des cycles nouveaux et spécialisés qui ne sont pas inclus parmi les cycles standards de l'appareil.

Les appareils qui ont été correctement connectés peuvent télécharger une variété de cycles de spécialité propres à l'appareil.

Une fois le cycle téléchargé dans l'appareil, ce dernier le conserve jusqu'à ce qu'un nouveau cycle soit téléchargé.

REMARQUE

- Un seul cycle téléchargé peut être enregistré à la fois sur l'appareil.

Caractéristiques du module LAN sans fil

Modèle	LCW-004 ou LCW-007
Gamme de fréquences	2412 - 2462 MHz

Puissance de sortie (Max.)	< 30 dBm
-----------------------------------	----------

Avis de la FCC

L'avis suivant couvre le module de transmetteur se trouvant dans le produit.

Cet équipement a été testé et jugé conforme aux limites d'un appareil numérique de classe B, conformément à la partie 15 des règles de la FCC. Ces limites sont établies pour fournir une protection raisonnable contre les interférences nuisibles dans une installation résidentielle. Cet équipement produit, utilise et peut émettre de l'énergie radioélectrique et, s'il n'est pas installé et utilisé conformément aux présentes instructions, peut causer des interférences nuisibles aux communications radio. Quoiqu'il en soit, on ne peut pas garantir que des interférences ne se produiront pas dans certaines installations. Si cet appareil cause des interférences nuisibles à la réception des signaux de radio ou de télévision, ce qui peut être déterminé en allumant et en éteignant l'appareil, on encourage l'utilisateur à essayer de corriger ces interférences par l'un des moyens suivants :

- Réorientez ou déplacez l'antenne de réception.
- Augmentez la distance séparant l'équipement du récepteur.
- Branchez l'appareil sur un circuit électrique différent de celui où le récepteur est branché.
- Contactez votre revendeur ou un technicien radio/télévision expérimenté.

Cet appareil est conforme à la partie 15 du règlement de la FCC. Le fonctionnement est soumis aux deux conditions suivantes :

- (1) L'appareil ne doit pas produire de brouillage; et
- (2) L'appareil doit accepter tout brouillage radioélectrique subi, même si le brouillage est susceptible d'en compromettre le fonctionnement.

Tout changement ou toute modification apportés à cet appareil et qui ne sont pas approuvés de manière explicite par le fabricant sont susceptibles d'annuler l'autorité de l'utilisateur quant à utiliser l'appareil.

Énoncé FCC sur l'exposition aux radiations RF

Cet équipement est conforme aux limites de radiation de la FCC définies pour un environnement non contrôlé. Cet appareil et sa ou ses antennes ne doivent pas être colocalisés ou

opérés en conjonction avec tout autre antenne ou transmetteur.

Cet appareil doit être installé et utilisé de façon à maintenir une distance minimale de 20 cm (7,8 po) entre l'antenne et l'utilisateur. Les utilisateurs doivent respecter les directives d'utilisation afin de satisfaire aux critères en matière d'exposition aux rayonnements RF.

Déclaration d'Industrie Canada

Cet appareil contient des transmetteurs et des récepteurs exempts de licence et conformes aux CNR d'Innovation, Sciences et Développement économique Canada applicables aux appareils radio exempts de licence. L'exploitation est autorisée aux deux conditions suivantes :

- (1) Cet appareil ne doit pas provoquer d'interférences;
- (2) Cet appareil doit accepter toutes les interférences, y compris celles pouvant entraîner son dysfonctionnement.

Avis d'Industrie Canada sur l'exposition aux rayonnements

Cet appareil est conforme aux limites d'exposition aux rayonnements d'Industrie Canada pour un environnement non contrôlé.

Cet appareil doit être installé de façon à garder une distance minimale de 20 cm (7,8 po) entre la source de rayonnement et votre corps.

REMARQUE

- LE FABRICANT N'EST PAS RESPONSABLE DES INTERFÉRENCES RADIOÉLECTRIQUES CAUSÉES PAR DES MODIFICATIONS NON AUTORISÉES APPORTÉES À CET APPAREIL. DE TELLES MODIFICATIONS POURRAIENT ANNULER L'AUTORISATION ACCORDÉE À L'UTILISATEUR DE FAIRE FONCTIONNER L'APPAREIL.



Renseignements sur l'avis de logiciel ouvert

Pour obtenir le code source conformément aux dispositions de la licence publique générale, de la licence publique générale limitée, de la licence publique Mozilla et de toute autre licence régissant les logiciels à code source libre contenus dans cet appareil, visitez le site <http://opensource.lge.com>. En plus du code source, toutes les dispositions de licence, les exonérations

de garantie et les avis de droits d'auteurs peuvent aussi être téléchargés.

LG Electronics mettra également à votre disposition le code source libre sur CD-ROM pour un prix couvrant le coût de la distribution (coût du support, de l'expédition et de la manutention) sur simple demande par courriel à l'adresse **opensource@lge.com**. Cette offre est valable pendant une période de trois ans à compter de la date de la dernière distribution de ce produit. Cette offre est valide pour quiconque possède cette information.

Fonctionnalité Smart Diagnosis^{MC}

Cette fonctionnalité est offerte uniquement sur les modèles portant le logo  ou .

Utilisez cette fonctionnalité pour vous aider à diagnostiquer et à résoudre les problèmes qu'éprouve votre appareil.

REMARQUE

- Pour des raisons ne relevant pas du contrôle de LGE, le service pourrait ne pas fonctionner en raison de facteurs externes, notamment la disponibilité du Wi-Fi, la connexion Wi-Fi, la politique de la boutique d'applications ou la disponibilité de l'application.
- La fonctionnalité pourrait être modifiée sans préavis et pourrait avoir une apparence différente selon votre emplacement.

Utilisation de l'application LG ThinQ pour diagnostiquer les problèmes



Si vous éprouvez des problèmes avec votre appareil doté du Wi-Fi, vous pouvez transmettre des données de dépannage par téléphone intelligent à l'aide de l'application **LG ThinQ**.

- Lancez l'application **LG ThinQ** et sélectionnez la fonctionnalité **Smart Diagnosis^{MC}** qui se trouve dans le menu. Suivez les instructions indiquées dans l'application **LG ThinQ**.

Utilisation de la fonctionnalité de diagnostic sonore pour diagnostiquer les problèmes

Suivez les instructions ci-dessous pour utiliser la fonctionnalité de diagnostic sonore.

- Lancez l'application **LG ThinQ** et sélectionnez la fonctionnalité **Smart Diagnosis^{MC}** qui se trouve dans le menu. Suivez les instructions relatives au diagnostic sonore indiquées dans l'application **LG ThinQ**.

- 1 Appuyez sur le bouton **Marche/arrêt** pour allumer l'appareil.
 - N'appuyez sur pas sur les autres touches.
- 2 Placez le microphone de votre téléphone intelligent tout près du logo  ou .

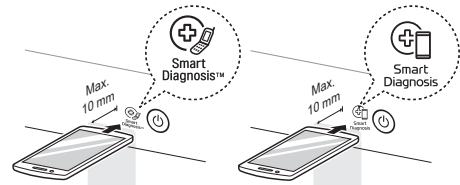

- 3 Maintenez le bouton **Temp. (Température)** enfoncé pendant **trois secondes** ou jusqu'à ce qu'un son se fasse entendre. Tenez le microphone de votre téléphone intelligent près de l'icône jusqu'à ce que le transfert des données soit terminé.
 - Maintenez votre téléphone intelligent en place jusqu'à ce que le transfert des données soit terminé. Le temps restant pour le transfert des données s'affiche à l'écran.
- 4 Une fois le transfert des données terminé, le diagnostic s'affichera dans l'application.

REMARQUE

- Pour obtenir des résultats optimaux, évitez de bouger votre téléphone intelligent pendant la transmission sonore.

ENTRETIEN

⚠ AVERTISSEMENT

- Pour réduire le risque d'incendie, de décharge électrique ou de blessures, lisez tout ce manuel d'utilisation, y compris les **DIRECTIVES DE SÉCURITÉ**, avant d'utiliser cet appareil.
- Débranchez l'appareil avant de le nettoyer pour éviter tout risque de décharge électrique. Le non-respect de cet avertissement peut entraîner des blessures graves, un incendie, une décharge électrique ou la mort.
- N'utilisez pas de substances volatiles (benzène, diluant à peinture, alcool, acétone, etc.), de nettoyeurs abrasifs ou de détergents contenant des composants chimiques forts lors du nettoyage de l'appareil. Vous risqueriez de provoquer une décoloration, d'endommager l'appareil ou de provoquer un incendie.
- Certaines pièces internes qui ne sont pas mises à la terre intentionnellement posent un risque de décharge électrique durant l'entretien seulement. Remarque à l'intention du personnel d'entretien – Évitez tout contact avec les pièces suivantes lorsque l'appareil est sous tension : la pompe, la soupape, le moteur et le panneau de commande.

Nettoyage régulier

Entretien après un lavage

Après la fin du cycle, essuyez la porte et l'intérieur du joint de la porte pour enlever l'humidité.

- Essuyez le bâti de la laveuse avec un linge sec pour enlever l'humidité.
- Laissez la porte ouverte pour que l'intérieur du tambour sèche.

⚠ AVERTISSEMENT

- Assurez-vous que les enfants et les animaux domestiques n'entrent pas dans le tambour. Utilisez la fonctionnalité **Control Lock (Verrouillage des commandes)** si nécessaire pour empêcher les enfants de démarrer accidentellement un cycle de lavage.

Nettoyage de l'extérieur

Bien entretenir votre laveuse peut prolonger sa durée de vie.

Porte :

Lavez avec un linge humide l'extérieur et l'intérieur, et asséchez ensuite avec un linge doux.

Extérieur :

- Essuyez immédiatement toute éclaboussure.
- Essuyez avec un linge humide.
- Ne touchez pas la surface ou l'écran avec des objets coupants.

Entretien périodique

- Utilisez une serviette ou un linge doux pour essuyer le tour de l'ouverture de la porte et le hublot de la porte.
- Retirez toujours les articles de la laveuse aussitôt que le cycle est terminé. Laisser des articles humides dans la laveuse peut causer des plis, le transfert de couleurs et des odeurs.

Nettoyage du tambour

Au fil du temps, des résidus peuvent s'accumuler dans le tambour, ce qui entraîne la formation de moisissure ou d'une odeur de moisi. Exécutez le cycle **Tub Clean (Nettoyage de la cuve)** chaque mois pour éliminer les résidus et prévenir les odeurs.

REMARQUE

- Assurez-vous d'exécuter le cycle **Tub Clean (Nettoyage de la cuve)** uniquement lorsque le tambour est vide. Ne placez jamais d'articles dans la cuve pendant l'utilisation de ce cycle. Les vêtements pourraient être endommagés ou contaminés par des produits de nettoyage.
- Exécutez le cycle plus souvent en cas d'utilisation intensive ou si des odeurs sont déjà présentes.
- S'il y a déjà de la moisissure ou si vous sentez déjà une odeur de moisi, exécutez ce cycle une fois par semaine pendant trois semaines consécutives.

- 1 Retirez tous les articles du tambour.

2 Ajoutez des agents de nettoyage.

Nettoyant	Instructions
Nettoyant pour tambour	Ajoutez-le au compartiment principal de détergent du distributeur de détergent.
Produit détartrant	
Javellisant chloré liquide	Ajoutez-le au compartiment de javellisant du distributeur de détergent.
Nettoyant en poudre	Retirez le contenant à détergent liquide avant de le mettre dans le compartiment à détergent principal.
Pastilles nettoyantes	Placez directement dans le tambour de la laveuse.

- Pour les autres produits de nettoyage du tambour, suivez les directives et les recommandations du fabricant.
- Ne dépassez pas la ligne de remplissage maximal quand vous ajoutez un javellisant ou des nettoyants en poudre. Le détergent en poudre pourrait rester dans le tambour après le lavage.

3 Fermez la porte et appuyez sur le bouton **Marche/arrêt**.

4 Sélectionnez le cycle **Tub Clean (Nettoyage de la cuve)** et appuyez sur le bouton **Démarrer/pause** pour lancer le cycle.

5 Lorsque le cycle est terminé, ouvrez la porte et laissez sécher complètement l'intérieur du tambour.

AVERTISSEMENT

- Assurez-vous que les enfants et les animaux domestiques n'entrent pas dans le tambour. Utilisez la fonctionnalité **Control Lock (Verrouillage des commandes)** si nécessaire pour empêcher les enfants de démarrer accidentellement un cycle de lavage.

REMARQUE

- Si vous utilisez un détartrant ou un nettoyant pour tambour pendant le cycle **Tub Clean (Nettoyage de la cuve)**, utilisez l'option **Rinse+Spin (Rinçage et essorage)** pour rincer le tambour de la laveuse avant de commencer votre prochain cycle de lavage.

Alerte automatique de nettoyage de la cuve

Lorsque l'appareil est sous tension et que le message **ECL** clignote à l'écran, cela signifie que le tambour a besoin d'être nettoyé. Utilisez le cycle **Tub Clean (Nettoyage de la cuve)** pour nettoyer le tambour de la laveuse. La fréquence de l'alerte automatique dépend du nombre d'utilisations de la laveuse. Toutefois, le message s'affiche normalement après un ou deux mois.

Nettoyage des dépôts minéraux

Si votre eau est dure, des dépôts minéraux peuvent s'accumuler sur les composants internes de la laveuse. Nettoyez régulièrement les dépôts minéraux sur les composants internes pour prolonger la durée de vie de la laveuse. L'utilisation d'un adoucisseur d'eau est recommandée si votre eau est dure.

- Utilisez un produit détartrant pour enlever les dépôts minéraux visibles sur le tambour de la laveuse.
- Après chaque détartrage, démarrez toujours le cycle **Tub Clean (Nettoyage de la cuve)** avant de laver des vêtements.
- Les dépôts minéraux et autres taches peuvent être enlevés du tambour en acier inoxydable avec un linge doux trempé dans un produit nettoyant pour acier inoxydable.
- N'utilisez pas de laine d'acier ni de nettoyants abrasifs.

Laissez la porte ouverte

Après avoir utilisé la laveuse, laissez la porte ouverte pendant la nuit afin de permettre à l'air de circuler et de sécher le tambour. Cela aidera à prévenir les odeurs.

Nettoyage du tiroir du distributeur

Le fait de laisser du détergent dans le tiroir du distributeur de détergent pendant une période prolongée ou d'utiliser la laveuse pendant une période prolongée peut causer une accumulation de résidus dans le tiroir du distributeur de détergent. Retirez et nettoyez le tiroir du distributeur de détergent **une à deux fois par mois**.

⚠ AVERTISSEMENT

- Ne vaporisez pas d'eau à l'intérieur de la laveuse. Vous risqueriez de provoquer un incendie ou une décharge électrique.

- 1 Éteignez la laveuse et débranchez le cordon d'alimentation.
- 2 Tirez le tiroir jusqu'à ce qu'il s'arrête.
- 3 Appuyez fortement sur le bouton de désengagement **1** et sortez complètement le tiroir.

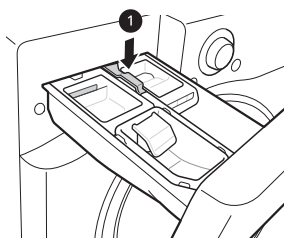

- 4 Retirez les insertions du tiroir.
- 5 Nettoyez les insertions et le tiroir à l'eau tiède.
 - Utilisez un chiffon doux ou une brosse pour nettoyer et enlever les résidus.
 - N'utilisez pas de savon pour nettoyer le tiroir et les insertions.
- 6 Essuyez toute trace d'humidité avec une serviette ou un linge sec après le nettoyage.
- 7 Nettoyez la cavité de l'ouverture du tiroir avec une petite brosse non métallique. Retirez tous les résidus logés dans les parties supérieures et inférieures de la cavité.
- 8 Remplacez le tiroir.

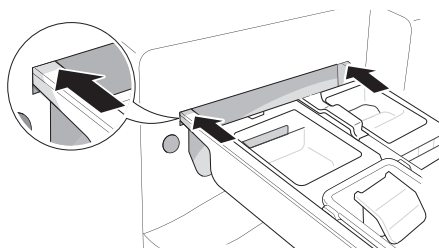
**Nettoyage du joint de la porte**

Nettoyez le joint de la porte **une fois par mois** pour prévenir l'accumulation de saleté.

⚠ MISE EN GARDE

- Le nettoyage du joint de la porte avec du javellisant non dilué pourrait altérer le joint de la porte et endommager les pièces de la laveuse. Vous devez ajouter de l'eau au javellisant avant de vous en servir.

- 1 Portez des gants de caoutchouc et des lunettes de protection.
- 2 Diluez 3/4 tasse (177 ml) de javellisant chloré liquide dans 3,8 l (1 gallon) d'eau.
- 3 Essuyez les pourtours du joint de la porte.
 - Trempez une éponge ou un linge doux dans cette solution diluée et essuyez partout autour du joint de la porte.
- 4 Après le nettoyage, essuyez l'humidité avec une serviette ou un tissu sec.
- 5 Laissez la porte ouverte pour permettre au joint de la porte de sécher complètement.

Nettoyage des filtres d'arrivée d'eau

Si la laveuse ne se remplit pas correctement, un code d'erreur s'affichera à l'écran. Les grilles des filtres de la soupape d'arrivée sont peut-être bouchées par des dépôts minéraux causés par de l'eau dure, des sédiments ou d'autres débris provenant du système d'approvisionnement en eau.

⚠ AVERTISSEMENT

- Les grilles d'arrivée protègent les pièces délicates de la soupape d'arrivée afin qu'elles ne soient pas endommagées par des particules qui pourraient entrer dans les soupapes lors de l'approvisionnement en eau. Le fait de faire fonctionner la laveuse sans ces filtres peut entraîner l'ouverture continue d'une soupape et provoquer des inondations et des dommages matériels.

⚠ MISE EN GARDE

- N'utilisez pas la laveuse sans ces filtres d'arrivée, car cela entraînera des fuites et un dysfonctionnement.
- Si votre eau est dure, les filtres d'arrivée d'eau pourraient devenir bouchés par l'accumulation de minéraux et nécessiter d'être nettoyés plus souvent.

- 1** Éteignez la laveuse et débranchez le cordon d'alimentation.
- 2** Fermez les robinets d'eau chaude et d'eau froide.
- 3** Dévissez les tuyaux d'eau chaude et d'eau froide de l'arrière de la laveuse.
- 4** Enlevez soigneusement les filtres des soupapes d'eau.
 - Utilisez des pinces pour retirer les filtres des soupapes d'eau.

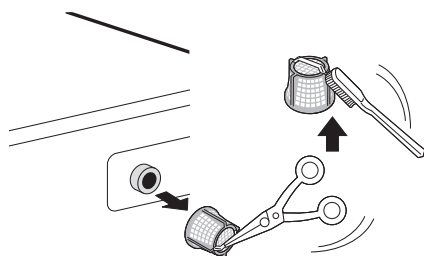

- 5** Enlevez les objets étrangers et faites tremper les filtres dans du vinaigre blanc ou dans un produit détartrant.
 - Si vous utilisez un produit détartrant, suivez les directives du fabricant. Faites bien attention de ne pas endommager les filtres en les nettoyant.
- 6** Rincez les filtres abondamment et remettez-les en place en appuyant dessus.
- 7** Purgez et raccordez ensuite les tuyaux d'eau.
 - Avant de remettre les tuyaux d'arrivée d'eau en place, purgez-les en y faisant couler plusieurs gallons d'eau dans une chaudière ou un drain, préférablement avec les robinets complètement ouverts pour obtenir une pression d'eau maximale.

REMARQUE

- Le message d'erreur i E peut clignoter sur l'afficheur lorsque la pression de l'eau est faible ou qu'un filtre d'arrivée est obstrué par de la saleté. Nettoyez le filtre d'arrivée.

Nettoyage du filtre de la pompe de vidange

La laveuse ne réussit pas à bien évacuer l'eau si le filtre de la pompe de vidange est obstrué. Nettoyez périodiquement le filtre de vidange pour empêcher qu'il se bouche avec des objets étrangers.

⚠ AVERTISSEMENT

- Ouvrir le filtre de vidange causera un déversement d'eau si le tambour de la laveuse en contient. Utilisez un seau si le tambour n'est pas complètement vidé avant d'ouvrir le filtre de vidange.
- L'utilisation de la laveuse sans le filtre de vidange ou avec un filtre de vidange mal assemblé peut provoquer des fuites ou un dysfonctionnement de la laveuse.

- 1** Éteignez la laveuse et débranchez le cordon d'alimentation.
- 2** Ouvrez le couvercle du filtre de la pompe de vidange.

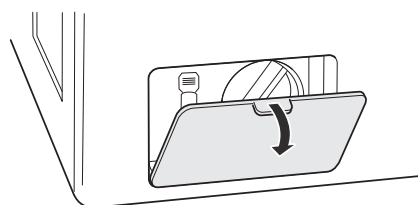

- 3** Évacuez toute l'eau qui reste.
 - Détachez le tuyau de vidange et enlevez le bouchon du tuyau pour évacuer l'eau restante.

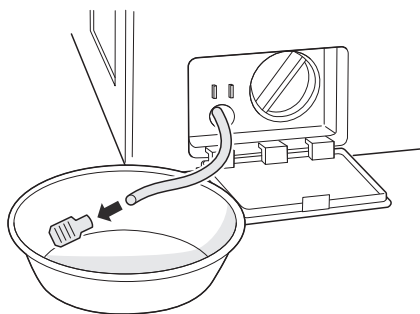

4 Enlevez le filtre de la pompe.

- Dévissez le filtre de la pompe dans le sens contraire des aiguilles d'une montre pour le retirer.

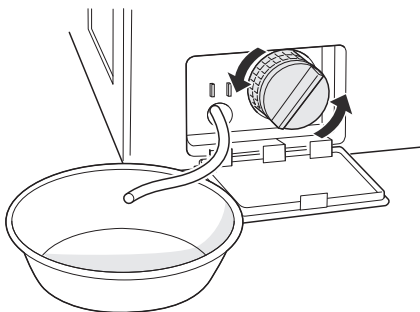

5 Nettoyez le filtre de la pompe et l'ouverture.

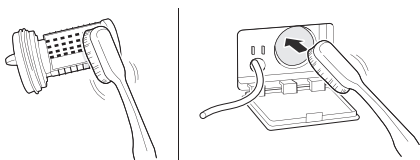

6 Remplacez le bouchon sur le tuyau de vidange et rattachez le tuyau de vidange.

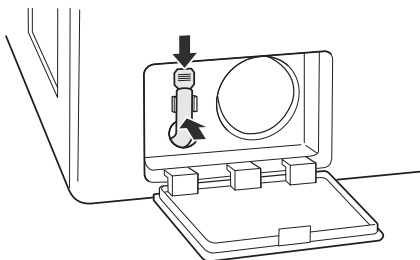

7 Insérez le filtre de la pompe de vidange.

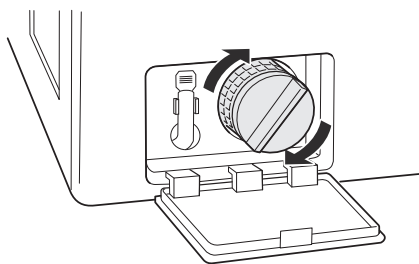

8 Refermez le couvercle du filtre de la pompe de vidange.

REMARQUE

- Un message  clignote sur l'affichage quand le filtre de la pompe de vidange est bouché par une accumulation de particules. Nettoyez le filtre de la pompe de vidange.

Entretien dans les climats froids

Entreposage de la laveuse

Si vous prévoyez ne pas utiliser la laveuse pendant une période prolongée et si elle se trouve dans une zone susceptible d'être exposée à des températures sous le point de congélation, procédez comme suit pour prévenir les dommages à la laveuse.

REMARQUE

- Assurez-vous que le tambour est vide avant de suivre ces étapes.

1 Éteignez la laveuse et débranchez le cordon d'alimentation.

2 Fermez les robinets d'eau.

3 Débranchez les tuyaux de l'alimentation en eau et évacuez l'eau des tuyaux.

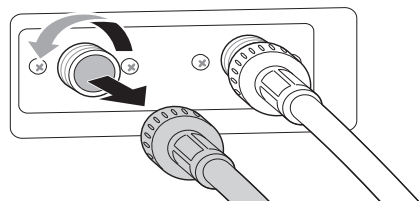

- 4 Branchez le cordon d'alimentation dans une prise électrique correctement mise à la terre.
 - 5 Versez un 1 gallon de produit antigel non toxique pour véhicules récréatifs dans le tambour vide et fermez la porte.
 - N'utilisez jamais de produit antigel pour automobiles.
 - 6 Allumez la laveuse et appuyez sur le bouton **Spin (Vitesse d'essorage)**.
 - 7 Appuyez sur le bouton **Démarrer/pause** pour activer la pompe de vidange pendant **1 minutes**.
 - Cette procédure évacue une partie du produit antigel, mais en laisse assez pour protéger la laveuse contre le gel.
 - 8 Éteignez la laveuse et débranchez le cordon d'alimentation.
 - 9 Essuyez l'intérieur du tambour avec un chiffon doux et fermez la porte.
 - 10 Entreposez la laveuse à la verticale.
 - 11 Enlevez les insertions du distributeur. Évacuez toute l'eau qui reste dans les compartiments et laissez-les sécher.
 - 12 Pour retirer le produit antigel de la laveuse après l'entreposage, faites un cycle **Rinse+Spin (Rinçage et essorage)** avec du détergent.
 - N'ajoutez pas de vêtements pour ce cycle.
- 4 Plongez les tuyaux d'arrivée d'eau dans de l'eau chaude pour les décongeler.
 - 5 Raccordez les tuyaux d'arrivée d'eau aux arrivées d'eau de la laveuse et aux robinets.
 - Consultez la section **Raccordement des tuyaux d'arrivée d'eau** pour obtenir plus de détails.
 - 6 Ouvrez les robinets.
 - 7 Appuyez sur le bouton **Marche/arrêt** pour allumer la laveuse.
 - 8 Appuyez sur le bouton **Spin (Vitesse d'essorage)** pour utiliser uniquement le cycle d'essorage pour le drainage et l'essorage.
 - 9 Appuyez sur le bouton **Démarrer/pause**.

Lorsque le tuyau de vidange est gelé

- 1 Éteignez la laveuse et débranchez le cordon d'alimentation.
- 2 Fermez les robinets raccordés aux tuyaux d'arrivée d'eau.
- 3 Versez de l'eau chaude sur les robinets gelés pour dégeler les tuyaux d'arrivée d'eau, puis enlevez ces derniers.

- 1 Versez de l'eau chaude dans le tambour de la laveuse et fermez la porte.
- 2 Attendez pendant **une à deux heures**.
- 3 Appuyez sur le bouton **Marche/arrêt**.
- 4 Appuyez sur le bouton **Spin (Vitesse d'essorage)** pour utiliser uniquement le cycle d'essorage pour le drainage et l'essorage.
- 5 Appuyez sur le bouton **Démarrer/pause** pour vous assurer que l'eau est bien évacuée.

DÉPANNAGE

Avant d'appeler le réparateur

La laveuse est dotée d'un système de surveillance automatique des erreurs qui détecte et diagnostique très tôt les problèmes. Si la laveuse ne fonctionne pas correctement ou ne fonctionne pas du tout, vérifiez ce qui suit avant d'appeler un technicien.

FAQ

Q : Pourquoi ma laveuse produit-elle des forts bruits de claquement quand elle se remplit d'eau?

R : Il s'agit en fait d'un problème avec la plomberie de votre maison. Quand la soupape d'eau de la laveuse se ferme, cela peut faire bouger les tuyaux dans votre maison, et le résultat est un fort bruit de claquement. Cet effet, appelé coup de bélier, peut être réduit en installant un dispositif antibélier. Vous pouvez vous procurer des antibéliers dans une quincaillerie ou un magasin de bricolage pour la maison à proximité.

Q : Pourquoi y a-t-il si peu d'eau dans ma laveuse? Comment cela peut-il laver les vêtements?

R : Les laveuses HE (haute efficacité) sont conçues pour laver correctement votre lessive tout en utilisant une quantité minimale d'eau et d'énergie. Parce que le volume d'eau est bas, la petite quantité de détergent utilisée est plus concentrée dans l'eau, ce qui donne un excellent rendement au lavage.

Q : Lorsque j'appuie sur un bouton, pourquoi la sècheuse émet-elle un son sans que rien ne se produise?

R : La fonctionnalité **Control Lock (Verrouillage des commandes)** est activée. Pour la désactiver, mettez la laveuse sous tension, puis appuyez sur le bouton **Control Lock (Verrouillage des commandes)** et maintenez-le enfoncé pendant **trois secondes**.

Q : Où dois-je verser les produits de lessive en poudre lorsque je fais mon lavage?

R : Si vous utilisez du détergent à lessive en poudre, mettez-le dans le compartiment principal du distributeur de détergent après avoir enlevé l'insertion pour le détergent liquide. Les détergents en poudre ou les agents de blanchiment en poudre non décolorants doivent être mis directement dans le tambour. Ces produits peuvent être mis dans le tambour vide avant le chargement des articles ou sur les articles déposés dans la laveuse.

Messages d'erreur

Symptômes	Causes possibles et solutions
I E ERREUR D'ENTRÉE D'EAU	Les robinets d'entrée d'eau ne sont pas complètement ouverts. <ul style="list-style-type: none"> Assurez-vous que les robinets d'entrée d'eau sont complètement ouverts.
	Les tuyaux d'entrée d'eau sont pliés, pincés ou écrasés. <ul style="list-style-type: none"> Assurez-vous que les tuyaux ne sont pas pliés, pincés ou écrasés derrière ou sous la laveuse. Faites attention lorsque vous déplacez la laveuse pendant le nettoyage ou l'entretien.
	Les filtres d'entrée d'eau sont bouchés. <ul style="list-style-type: none"> Nettoyez les filtres d'entrée. Consultez la partie ENTRETIEN.
	La pression d'eau de la résidence est trop faible. <ul style="list-style-type: none"> Vérifiez un autre robinet pour vous assurer que la pression d'eau de la maison est adéquate et que le débit n'est pas restreint. Débranchez les tuyaux d'entrée d'eau de la laveuse et faites couler quelques gallons d'eau dans les tuyaux pour rincer les saletés qui pourraient s'y trouver. Si le débit est trop faible, communiquez avec un plombier pour faire réparer les conduites d'alimentation en eau.
UE ERREUR RELATIVE À UN DÉSÉQUILIBRE	L'alimentation d'eau est connectée avec des boyaux antifuite. <ul style="list-style-type: none"> L'utilisation de tuyaux de limitation des fuites n'est pas recommandée. Ces tuyaux peuvent s'activer faussement et empêcher la laveuse de se remplir.
	La brassée est trop petite. <ul style="list-style-type: none"> Ajoutez des articles supplémentaires pour permettre à la laveuse d'équilibrer la brassée.
	Des articles lourds sont mélangés avec des articles légers. <ul style="list-style-type: none"> Essayez toujours de laver des articles d'un poids similaire pour permettre à la laveuse de distribuer la charge uniformément durant l'essorage.
dE, dE 1, dE2, dE4 ERREUR D'OUVERTURE DE LA PORTE	La brassée est déséquilibrée. <ul style="list-style-type: none"> Redistribuez manuellement la brassée si les articles se sont enchevêtrés et empêchent le bon fonctionnement du rééquilibrage automatique.
	La porte n'est pas bien fermée. <ul style="list-style-type: none"> Fermez bien la porte. Si le message continue à apparaître, débranchez le cordon d'alimentation et appelez un technicien.
E ERREUR D'ÉVACUATION D'EAU	Le tuyau de vidange est écrasé, pincé ou bouché. <ul style="list-style-type: none"> Assurez-vous que le tuyau de vidange n'est pas obstrué et qu'il n'est pas pincé derrière ou sous la laveuse.
	L'extrémité du tuyau de vidange ne doit pas se trouver à plus de 96 pouces (2,4 m) au-dessus de la partie inférieure de la laveuse. <ul style="list-style-type: none"> Déplacez l'extrémité du boyau d'évacuation de façon à ce qu'il ne se trouve pas à une hauteur de plus de 96 pouces (2,4 m).
E ERREUR LIÉE AU CAPTEUR DE TEMPÉRATURE	Erreur de commande. <ul style="list-style-type: none"> Débranchez la laveuse et attendez 60 minutes. Rebranchez l'alimentation et réessayez. Si le code d'erreur s'affiche toujours, contactez un technicien.
F ERREUR DE DÉBORDEMENT	Le niveau d'eau est trop élevé en raison d'une soupape défectueuse. <ul style="list-style-type: none"> Fermez les robinets, débranchez la laveuse et appelez un technicien.

Symptômes	Causes possibles et solutions
PE ERREUR DE CAPTEUR DE PRESSION	Le capteur de niveau d'eau ne fonctionne pas correctement. <ul style="list-style-type: none"> Fermez les robinets, débranchez la laveuse et appelez un technicien.
LE ERREUR DE VERROUILLAGE DU MOTEUR	Une erreur de moteur s'est produite. <ul style="list-style-type: none"> Laissez la laveuse reposer pendant 30 minutes et redémarrez le cycle. Si le code d'erreur s'affiche toujours, contactez un technicien.
5ud QUANTITÉ EXCESSIVE DE BULLES DÉTECTÉE	Le détergent produit trop de bulles <ul style="list-style-type: none"> N'ajoutez pas plus de détergent que la quantité recommandée par le fabricant. Pour éliminer les bulles, mettez la laveuse hors tension puis sous tension, puis lancez le cycle Rinse+Spin (Rinçage et essorage). Si une trop grande quantité de mousse est détectée pendant l'essorage, la laveuse s'arrête pour éviter toute fuite.
PF ERREUR LIÉE AU CAPTEUR DE NIVEAU D'EAU	Le niveau d'eau est trop bas ou trop élevé par rapport à la brassée. <ul style="list-style-type: none"> Débranchez la laveuse et attendez pendant 60 minutes. Rebranchez l'alimentation et réessayez. Si le code d'erreur s'affiche toujours, contactez un technicien.
FF ERREUR CAUSÉE PAR LE FROID	Le tuyau d'arrivée, le tuyau de vidange ou la pompe de vidange sont gelés. <ul style="list-style-type: none"> Consultez la section Entretien dans les climats froids.
CL FONCTION CONTROL LOCK (VERROUILLAGE DES COMMANDES)	La fonctionnalité Control Lock (Verrouillage des commandes) est activée afin d'empêcher quiconque de modifier les cycles ou de faire fonctionner la laveuse. <ul style="list-style-type: none"> Désactivez la fonction Control Lock (Verrouillage des commandes) dans le panneau de commande. Consultez la partie Control Lock (Verrouillage des commandes) dans la section Options et fonctions supplémentaires.
EcL ALARME DE NETTOYAGE DE LA CUVE	Il est temps de lancer le cycle Tub Clean (Nettoyage de la cuve). <ul style="list-style-type: none"> Il ne s'agit pas d'un code d'erreur. Il indique que le cycle Tub Clean (Nettoyage de la cuve) est en cours ou doit être exécuté pour nettoyer le tambour de la laveuse.
u5 ERREUR DU CAPTEUR DE VIBRATION	Le capteur de vibration ne fonctionne pas bien. <ul style="list-style-type: none"> Communiquez avec un centre de services.

Bruits

Symptômes	Causes possibles et solutions
Cliquètement	Un signal sonore se fait entendre lorsque la porte se verrouille et se déverrouille. <ul style="list-style-type: none"> Fonctionnement normal
Vaporisation ou sifflement	Eau qui est distribuée ou qui circule durant le cycle. <ul style="list-style-type: none"> Fonctionnement normal
Bourdonnement ou gargouillement	La pompe d'évacuation pompe l'eau de la laveuse quelques fois durant un cycle. <ul style="list-style-type: none"> Fonctionnement normal
De l'eau qui remue	Un liquide dans l'anneau d'équilibrage autour du pulseur aide le panier à tourner en douceur. <ul style="list-style-type: none"> Fonctionnement normal

Symptômes	Causes possibles et solutions
Eau ajoutée après que la laveuse a déjà commencé à fonctionner	La laveuse s'adapte en fonction de la grosseur et du type de brassée, et rajoute plus d'eau au besoin. <ul style="list-style-type: none"> Fonctionnement normal
	La brassée est peut-être déséquilibrée. Si la laveuse détecte que la brassée est déséquilibrée, elle arrête de fonctionner et se remplit pour redistribuer la charge. <ul style="list-style-type: none"> Fonctionnement normal
	La laveuse dilue peut-être les additifs pour la lessive pour les ajouter à la brassée. <ul style="list-style-type: none"> Fonctionnement normal
Claquement et cliquetis	Des objets étrangers (clés, pièces de monnaie ou épingles de sûreté) peuvent se retrouver dans le tambour ou la pompe. <ul style="list-style-type: none"> Arrêtez la laveuse et vérifiez qu'il n'y a pas de corps étrangers dans le tambour et le filtre d'évacuation. Si le bruit persiste après le redémarrage de la laveuse, communiquez avec un centre de service.
Bruit sourd	Les grosses brassées peuvent produire un bruit sourd. <ul style="list-style-type: none"> C'est normal. Si le bruit persiste, la laveuse est probablement déséquilibrée. Arrêtez et redistribuez la brassée.
	La brassée est peut-être déséquilibrée. <ul style="list-style-type: none"> Suspendez le cycle et répartissez la brassée après le déverrouillage de la porte.
Bruit de vibrations	Il reste du matériel d'emballage sur la laveuse. <ul style="list-style-type: none"> Consultez la partie Déballage et retrait du matériel d'emballage dans la section INSTALLATION.
	La brassée est peut-être mal distribuée dans le tambour. <ul style="list-style-type: none"> Suspendez le cycle et répartissez la brassée après le déverrouillage de la porte.
	Les pieds de nivellement ne sont pas tous fermement et également appuyés sur le plancher. <ul style="list-style-type: none"> Consultez la partie Mise à niveau de la laveuse dans la section INSTALLATION.
	Le plancher n'est pas assez solide. <ul style="list-style-type: none"> Assurez-vous que le plancher est solide et qu'il ne fléchit pas. Consultez la partie Plancher dans la section INSTALLATION.
Bruit de grincement	Il reste du matériel d'emballage sur la laveuse. <ul style="list-style-type: none"> Consultez la partie Déballage et retrait du matériel d'emballage dans la section INSTALLATION.
Bruit de claquement lorsque la laveuse se remplit d'eau (coup de bélier).	La plomberie dans la maison bouge ou fléchit quand les soupapes d'eau dans la laveuse se referment. <ul style="list-style-type: none"> Le coup de bélier n'est pas le résultat d'un défaut de la laveuse. Installez des dispositifs antibéliers (achetés séparément dans une quincaillerie ou un centre de bricolage pour la maison) entre le boyau de remplissage et la laveuse pour les meilleurs résultats.
	La pression de l'arrivée d'eau dans la maison est très élevée. <ul style="list-style-type: none"> Réglez le régulateur de l'arrivée d'eau à une pression plus faible ou contactez un plombier.

FONCTIONNEMENT

Symptômes	Causes possibles et solutions
Fuite d'eau	<p>Les tuyaux ne sont pas raccordés correctement.</p> <ul style="list-style-type: none"> • Vérifiez qu'il n'y a pas de fuites, de fissures et de fentes dans les tuyaux et les raccords. • Vérifiez et serrez le raccordement des boyaux.
	<p>Les tuyaux d'évacuation de la résidence sont bouchés.</p> <ul style="list-style-type: none"> • La laveuse évacue l'eau très rapidement. Vérifiez si l'eau refoule du tuyau d'évacuation pendant l'évacuation de la cuve. Si vous voyez de l'eau qui sort du drain, vérifiez que le tuyau de vidange est correctement installé et assurez-vous qu'il n'y a pas de restrictions dans le drain. • Communiquez avec un plombier pour réparer le tuyau de vidange.
	<p>Le tuyau de vidange est sorti du raccord de vidange ou n'est pas inséré suffisamment loin.</p> <ul style="list-style-type: none"> • Fixez le boyau d'évacuation au boyau d'entrée ou au tuyau vertical pour l'empêcher de se déloger durant l'évacuation de la cuve. • Pour les tuyaux d'évacuation plus petits, insérez le boyau d'évacuation dans le tuyau jusqu'à la bride du boyau d'évacuation. Pour les plus gros tuyaux d'évacuation, insérez le boyau d'évacuation dans le tuyau à une distance de un à deux pouces après la bride.
	<p>Le détergent produit trop de bulles</p> <ul style="list-style-type: none"> • Un excès de bulles peut créer des fuites. Il peut être causé par le type et la quantité de détergent utilisé. Utilisez uniquement du détergent haute efficacité (HE). La quantité normale de détergent à utiliser est du quart (1/4) ou de la moitié (1/2) de la quantité maximale recommandée par le fabricant du détergent. • Réduisez toujours la quantité de détergent pour une petite brassée ou une brassée d'articles légèrement sales, ou si l'eau est très douce. • N'utilisez jamais plus que la quantité maximale recommandée par le fabricant du détergent.
Excès de bulles	<p>Trop de détergent ou mauvais détergent</p> <ul style="list-style-type: none"> • Les détergents HE sont conçus spécialement pour les laveuses haute efficacité et comportent des agents de réduction de bulles. Utilisez seulement du détergent comportant le logo Haute efficacité (HE). • Consultez la partie Usage du détergent, dans la section FONCTIONNEMENT pour connaître les quantités de détergent à utiliser. Si la mousse ou les résidus de détergent continuent de vous causer des ennuis, ajoutez un rinçage supplémentaire.
La laveuse ne s'allume pas.	<p>Le câble d'alimentation n'est pas correctement branché.</p> <ul style="list-style-type: none"> • Vérifiez que le câble d'alimentation est branché sur une prise c.a. à 3 trous (Mise à la terre) de 120 V/60 Hz.
	<p>Un fusible de votre résidence est brûlé, un disjoncteur a été déclenché ou il y a une panne de courant.</p> <ul style="list-style-type: none"> • Réinitialisez le disjoncteur ou remplacez le fusible. N'augmentez pas la capacité du fusible. S'il s'agit d'un problème de surcharge du circuit, faites-le corriger par un électricien qualifié.
Le cycle de lavage prend plus de temps que d'habitude.	<p>La laveuse ajuste automatiquement la durée du cycle en fonction de la charge, de la pression d'eau et des conditions de fonctionnement.</p> <ul style="list-style-type: none"> • C'est normal. La laveuse ajuste automatiquement la durée du cycle afin d'optimiser les résultats pour le cycle sélectionné. La durée affichée n'est qu'une estimation. La durée réelle peut être différente.

Symptômes	Causes possibles et solutions
Distribution incomplète ou aucune distribution de détergent	<p>Les compartiments à détergent sont bouchés à cause d'un remplissage incorrect.</p> <ul style="list-style-type: none"> • Assurez-vous que le détergent et les additifs sont placés dans les bons compartiments du distributeur. • Pour tous les types de détergent, assurez-vous toujours que le tiroir du distributeur est complètement fermé avant le démarrage du cycle.
	<p>Trop de détergent utilisé.</p> <ul style="list-style-type: none"> • Assurez-vous que la quantité suggérée de détergent est utilisée selon les recommandations du fabricant. Vous pouvez aussi diluer le détergent avec de l'eau jusqu'au niveau de remplissage maximal du compartiment pour éviter les obstructions. N'utilisez que des détergents HE (haute efficacité).
	<p>REMARQUE</p> <ul style="list-style-type: none"> • Utilisez toujours aussi peu de détergent que possible. Les laveuses à haute efficacité (HE) n'ont besoin que d'une très petite quantité de détergent pour obtenir des résultats optimaux. Utiliser trop de détergent causera un lavage et un rinçage de mauvaise qualité et pourrait entraîner des odeurs dans la laveuse.
	<p>Approvisionnement en eau insuffisant</p> <ul style="list-style-type: none"> • Vérifiez que les robinets d'eau chaude et d'eau froide sont tous les deux complètement ouverts.
	<p>Résidus normaux</p> <ul style="list-style-type: none"> • Il est normal qu'une petite quantité de détergent demeure dans le distributeur. Si ces résidus s'accumulent, ils peuvent empêcher la distribution normale des produits. Consultez les directives de nettoyage.

Symptômes	Causes possibles et solutions
<p>La laveuse ne fonctionne pas.</p>	<p>Le panneau de contrôle s'est éteint après une période d'inactivité.</p> <ul style="list-style-type: none"> • C'est tout à fait normal. Appuyez sur le bouton Marche/arrêt pour allumer la laveuse.
	<p>La laveuse est débranchée.</p> <ul style="list-style-type: none"> • Assurez-vous que le cordon d'alimentation est bien branché dans une prise électrique.
	<p>L'approvisionnement en eau est fermé.</p> <ul style="list-style-type: none"> • Ouvrez complètement le robinet d'eau froide et le robinet d'eau chaude.
	<p>Les commandes ne sont pas réglées correctement.</p> <ul style="list-style-type: none"> • Assurez-vous que le cycle a été réglé correctement, fermez la porte et appuyez sur le bouton Démarrer/pause pour démarrer le cycle de lavage.
	<p>La porte est ouverte.</p> <ul style="list-style-type: none"> • Fermez la porte et assurez-vous que rien n'est coincé dans la porte, ce qui l'empêcherait de se fermer complètement.
	<p>Le disjoncteur ou le fusible du circuit est déclenché ou brûlé.</p> <ul style="list-style-type: none"> • Vérifiez les disjoncteurs et les fusibles de la maison. Remplacez les fusibles grillés ou remettez les disjoncteurs en place. La laveuse doit être branchée sur un circuit électrique indépendant.
	<p>Vous n'avez pas appuyé sur le bouton Démarrer/pause après avoir réglé le cycle.</p> <ul style="list-style-type: none"> • Appuyez sur le bouton Marche/arrêt puis resélectionnez le cycle souhaité et appuyez sur le bouton Démarrer/pause. Si vous n'appuyez pas sur le bouton Démarrer/pause dans un certain délai, la laveuse s'éteindra. (Le délai peut varier selon le modèle, et se situer entre 4 et 60 minutes.)
	<p>La pression d'eau est très faible.</p> <ul style="list-style-type: none"> • Ouvrez un autre robinet de votre résidence pour vérifier si la pression d'eau est adéquate.
<p>La cuve ne se remplit pas correctement.</p>	<p>La laveuse est trop froide.</p> <ul style="list-style-type: none"> • Si la laveuse a été exposée à des températures sous le point de congélation pendant une longue période, laissez-la se réchauffer avant d'appuyer sur le bouton Marche/arrêt. Sinon, l'écran ne s'allumera pas.
	<p>Le filtre est obstrué.</p> <ul style="list-style-type: none"> • Vérifiez que les filtres d'entrée des soupapes d'entrée d'eau ne sont pas bouchés. Reportez-vous à la partie Nettoyage des filtres d'entrée d'eau dans la section ENTRETIEN.
	<p>Les boyaux d'entrée d'eau sont peut-être écrasés.</p> <ul style="list-style-type: none"> • Vérifiez si les boyaux d'entrée d'eau sont écrasés ou bouchés.
	<p>Efficacité énergétique</p> <ul style="list-style-type: none"> • Il s'agit d'une laveuse à haute efficacité (HE). Par conséquent, les réglages du niveau d'eau de cette laveuse peuvent être différents de ceux des laveuses conventionnelles.
	<p>Approvisionnement en eau insuffisant</p> <ul style="list-style-type: none"> • Vérifiez que les robinets d'eau chaude et d'eau froide sont tous les deux complètement ouverts.
	<p>La porte de la laveuse est ouverte.</p> <ul style="list-style-type: none"> • Fermez la porte et assurez-vous que rien n'est coincé dans la porte, ce qui l'empêcherait de se fermer complètement.
	<p>Le niveau d'eau est trop bas.</p> <ul style="list-style-type: none"> • Normalement, l'eau ne recouvre pas les vêtements. Le niveau de remplissage est optimisé en fonction du mouvement de lavage pour offrir des résultats de lavage optimaux.

Symptômes	Causes possibles et solutions
L'eau dans la laveuse ne s'écoule pas ou s'écoule lentement.	Le tuyau de vidange est écrasé, pincé ou bouché. <ul style="list-style-type: none"> Assurez-vous que le tuyau de vidange n'est pas obstrué et qu'il n'est pas pincé derrière ou sous la laveuse.
	L'extrémité du tuyau de vidange se trouve à plus de 96 pouces (2,4 m) au-dessus de la partie inférieure de la laveuse. <ul style="list-style-type: none"> Déplacez l'extrémité du boyau d'évacuation de façon à ce qu'il ne se trouve pas à une hauteur de plus de 96 pouces (2,4 m).
Le javellisant n'est pas distribué.	Le couvercle du distributeur de javellisant n'est pas correctement installé (sur certains modèles). <ul style="list-style-type: none"> Assurez-vous que le couvercle du javellisant est correctement installé et s'est bien mis en place avant le début du cycle.
	Le distributeur de javellisant est sale ou obstrué. <ul style="list-style-type: none"> Soulevez le couvercle du distributeur de javellisant et nettoyez le réservoir. Les peluches et autres débris qui s'accumulent dans le distributeur peuvent empêcher une bonne distribution du javellisant.
Le javellisant est distribué trop tôt.	Le distributeur de javellisant est rempli pour une brassée future. <ul style="list-style-type: none"> Vous ne pouvez pas mettre du javellisant dans le distributeur pour un usage futur. Le javellisant sera distribué à chaque brassée.
	Le distributeur de javellisant est trop rempli. <ul style="list-style-type: none"> Le remplissage excessif du distributeur de javellisant entraînera la distribution immédiate du javellisant, ce qui endommagera les articles ou la laveuse. Mesurez toujours la quantité de javellisant, mais ne dépassez jamais la ligne de capacité maximale du distributeur. Une demi-tasse de javellisant est suffisante pour la plupart des brassées. N'utilisez jamais plus d'une tasse de javellisant.

Performances

Symptômes	Causes possibles et solutions
Plis	La laveuse n'a pas été déchargée assez rapidement. <ul style="list-style-type: none"> Retirez toujours les articles de la laveuse aussitôt que le cycle est terminé.
	La laveuse est surchargée. <ul style="list-style-type: none"> La laveuse peut être complètement remplie, mais les articles ne doivent pas être compressés dans le tambour. La porte de la laveuse doit pouvoir être fermée facilement.
	Les boyaux d'entrée d'eau chaude et d'eau froide sont inversés. <ul style="list-style-type: none"> Un rinçage à l'eau chaude peut créer des plis dans les articles. Vérifiez le raccordement des boyaux.

Symptômes	Causes possibles et solutions
Taches	<p>Le javellisant ou l'assouplissant est distribué trop tôt.</p> <ul style="list-style-type: none"> Le compartiment du distributeur a été trop rempli ou fermé trop rapidement, ce qui a entraîné la distribution immédiate du javellisant ou de l'assouplissant. Il faut toujours mesurer le javellisant et ne jamais utiliser plus d'une tasse.
	<p>Un agent de blanchiment ou de l'assouplisseur a été versé directement sur les articles dans le tambour.</p> <ul style="list-style-type: none"> Utilisez toujours le distributeur pour vous assurer que les produits de lessive sont correctement distribués, au bon moment durant le cycle.
	<p>On n'a pas déchargé la laveuse promptement.</p> <ul style="list-style-type: none"> Enlevez toujours les articles de la laveuse dès que possible après la fin du cycle.
	<p>On n'a pas déchargé la laveuse promptement.</p> <ul style="list-style-type: none"> Enlevez toujours les articles de la laveuse dès que possible après la fin du cycle.
	<p>Les articles n'ont pas été triés correctement.</p> <ul style="list-style-type: none"> Lavez toujours les articles foncés séparément des articles blancs ou pâles pour éviter le transfert de couleurs. Ne lavez jamais d'articles très sales avec des articles légèrement sales.
Les vêtements restent tachés	<p>Les options adéquates n'ont pas été sélectionnées.</p> <ul style="list-style-type: none"> La saleté plus importante et les taches plus tenaces peuvent nécessiter une puissance de nettoyage supplémentaire. Sélectionnez la fonctionnalité Heavy (Très sale) pour accroître la puissance de nettoyage du cycle sélectionné.
	<p>Taches déjà imprégnées.</p> <ul style="list-style-type: none"> Les articles peuvent comporter des taches qui sont déjà imprégnées depuis un certain temps. Ces taches peuvent être difficiles à éliminer. Un lavage à la main ou un prétraitement pourrait aider à éliminer ces taches.
Odeur de moisi dans la laveuse	<p>Trop de détergent, ou un mauvais détergent, a été utilisé.</p> <ul style="list-style-type: none"> Utilisez uniquement un détergent à haute efficacité (HE), conformément aux instructions du fabricant.
	<p>L'intérieur du tambour n'a pas été correctement nettoyé.</p> <ul style="list-style-type: none"> Utilisez régulièrement le cycle de Tub Clean (Nettoyage de la cuve).

Odeur

Symptômes	Causes possibles et solutions
Odeur	<p>Certaines odeurs sont causées par le caoutchouc attaché à la laveuse.</p> <ul style="list-style-type: none"> Cette odeur est normale pour du caoutchouc neuf, et elle disparaîtra après que la laveuse aura été utilisée à quelques reprises.
	<p>Si le joint d'étanchéité en caoutchouc et la zone d'étanchéité de la porte ne sont pas nettoyés régulièrement, des odeurs provenant de moisissures ou de corps étrangers peuvent se faire sentir.</p> <ul style="list-style-type: none"> Assurez-vous de nettoyer régulièrement le joint d'étanchéité de la porte, et vérifiez sous le joint si de petits articles s'y trouvent lorsque vous retirez la brassée de la laveuse.
	<p>Des odeurs peuvent se dégager si des corps étrangers demeurent dans le filtre de la pompe de vidange.</p> <ul style="list-style-type: none"> Assurez-vous de nettoyer régulièrement le filtre de la pompe de vidange.
	<p>Des odeurs peuvent se dégager si le tuyau de vidange n'est pas correctement installé, provoquant le pompage de l'eau (ce qui signifie que l'eau est réacheminée à l'intérieur de la laveuse).</p> <ul style="list-style-type: none"> Lorsque vous installez le tuyau de vidange, assurez-vous qu'il n'est pas plié ni bloqué.
	<p>Si vous utilisez la fonction de séchage, des odeurs peuvent se dégager si des peluches et d'autres articles de lessive se fixent à l'élément chauffant. (Modèle avec sècheuse seulement)</p> <ul style="list-style-type: none"> Cela ne signifie pas que l'appareil est défectueux.
	<p>Une odeur particulière peut émaner lorsque des vêtements humides sont séchés avec de l'air chaud. (Modèle avec sècheuse seulement)</p> <ul style="list-style-type: none"> Cette odeur se dissipera après un moment.

Wi-Fi

Symptômes	Causes possibles et solutions
L'appareil et le téléphone intelligent n'arrivent pas à se connecter au réseau Wi-Fi.	<p>Le mot de passe du réseau Wi-Fi a été mal saisi.</p> <ul style="list-style-type: none"> Supprimez votre réseau Wi-Fi domestique et recommencez le processus de connexion.
	<p>Les données mobiles de votre téléphone intelligent sont activées.</p> <ul style="list-style-type: none"> Désactivez les données mobiles de votre téléphone intelligent avant de connecter l'appareil.
	<p>Le nom du réseau sans fil (SSID) est erroné.</p> <ul style="list-style-type: none"> Le nom du réseau sans fil (SSID) doit être une combinaison de lettres et de chiffres anglais. (N'utilisez pas de caractères spéciaux.)
	<p>La fréquence du routeur n'est pas de 2,4 GHz.</p> <ul style="list-style-type: none"> Seule une fréquence de routeur de 2,4 GHz est prise en charge. Réglez le routeur sans fil à 2,4 GHz et connectez-y l'appareil. Pour connaître la fréquence du routeur, informez-vous auprès de votre fournisseur de services Internet ou du fabricant du routeur.
	<p>L'appareil et le routeur sont trop éloignés l'un de l'autre.</p> <ul style="list-style-type: none"> Si l'appareil est trop éloigné du routeur, le signal peut être faible et la connexion peut ne pas être configurée correctement. Placez le routeur plus près de l'appareil ou achetez et installez un répéteur Wi-Fi.

GARANTIE LIMITÉE

POUR CANADA

CONDITIONS

AVIS D'ARBITRAGE : LA PRÉSENTE GARANTIE LIMITÉE CONTIENT UNE DISPOSITION SUR L'ARBITRAGE QUI EXIGE QUE LE RÈGLEMENT DES DIFFÉRENDS ENTRE VOUS ET LG S'EFFECTUE PAR ARBITRAGE EXÉCUTOIRE PLUTÔT QUE DEVANT UN TRIBUNAL, À MOINS QUE LES LOIS DE VOTRE PROVINCE OU TERRITOIRE L'INTERDISENT OU QUE, DANS UN AUTRE TERRITOIRE DE COMPÉTENCE, VOUS VOUS PRÉVALIEZ D'UNE OPTION DE RETRAIT. LES RECOURS COLLECTIFS ET LES PROCÈS DEVANT JURY NE SONT PAS AUTORISÉS PAR LE PROCESSUS D'ARBITRAGE. VEUILLEZ VOUS RÉFÉRER CI-DESSOUS À L'ARTICLE « PROCÉDURE DE RÈGLEMENT DE DIFFÉREND ».

Si votre laveuse LG (« produit ») est tombée en panne en raison d'un défaut de matériaux ou de fabrication sous une utilisation normale et appropriée, pendant la période de garantie indiquée ci-dessous, LG Electronics Canada inc. (« LGECI »), à son gré, réparera ou remplacera le produit après réception de la preuve d'achat originale au détail. Cette garantie limitée n'est valable uniquement qu'à l'acheteur original du produit et s'applique uniquement à un produit distribué, acheté et utilisé au Canada, tel que déterminé à la seule discrétion de LGECI.

PÉRIODE DE GARANTIE : (Remarque : Dans le cas où la date d'achat initial ne peut pas être vérifiée, la garantie commence soixante (60) jours après la date de fabrication.)		
Laveuse	Cuve en acier inoxydable	Moteur à entraînement direct (moteur ou rotor)
Un (1) an à compter de la date initiale d'achat au détail	Trois (3) ans à compter de la date initiale d'achat au détail.	Dix (10) ans après la date d'achat original de l'appareil.
Pièces et main-d'oeuvre (pièces internes fonctionnelles seulement)	Pièces seulement (le consommateur sera facturé pour la main-d'œuvre)	Pièce seulement (le consommateur sera facturé pour la main-d'œuvre)

- Les produits et pièces de remplacement sont garantis pour la portion restante de la période de garantie originale ou quatre-vingt-dix (90) jours, selon la période la plus longue.
- Les pièces et les produits de rechange peuvent être neufs, reconditionnés, remis à neuf ou réusinés, à la seule discrétion de LGECI.
- La preuve de l'achat de détail original spécifiant le modèle du produit et la date d'achat est requise pour obtenir un service sous garantie en vertu de la présente garantie limitée.

LA RESPONSABILITÉ DE LGECI EST LIMITÉE À LA GARANTIE LIMITÉE EXPRIMÉE CI-DESSUS. À L'EXCEPTION DES CAS EXPRESSÉMENT DÉCRITS CI-DESSUS, LGECI DÉCLINE TOUTE AUTRE GARANTIE ET CONDITION CONCERNANT LE PRODUIT, EXPLICITE OU IMPLICITE, Y COMPRIS, MAIS SANS S'Y LIMITER, TOUTE GARANTIE IMPLICITE OU CONDITION DE QUALITÉ MARCHANDE OU D'ADAPTATION À UN USAGE PARTICULIER, ET AUCUNE REPRÉSENTATION NE SERA LIÉE À LGECI. LGECI N'AUTORISE AUCUNE PERSONNE À CRÉER OU À ENDOSSER EN SON NOM TOUTE AUTRE OBLIGATION DE GARANTIE OU RESPONSABILITÉ RELATIVE AU PRODUIT. DANS LA MESURE OÙ TOUTE GARANTIE OU CONDITION EST IMPLICITE PAR LA LOI, ELLE EST LIMITÉE À LA PÉRIODE DE GARANTIE INDIQUÉE CI-DESSUS. EN AUCUN CAS, LGECI, LE FABRICANT OU LE DISTRIBUTEUR DU PRODUIT NE SERONT TENUS RESPONSABLES DE TOUT DOMMAGE ACCESSOIRE, CONSÉCUTIF, SPÉCIAL, DIRECT, INDIRECT, PUNITIF OU EXEMPLAIRE, Y COMPRIS, MAIS SANS S'Y LIMITER, LA PERTE DE CLIENTÈLE, LA PERTE DE PROFITS, LA PERTE DE PROFITS ANTICIPÉS, LA PERTE DE REVENUS, LA PERTE D'UTILISATION OU TOUT AUTRE DOMMAGE, QU'IL PROVIENNE DIRECTEMENT OU INDIRECTEMENT DE TOUTE INFRACTION CONTRACTUELLE, VIOLATION FONDAMENTALE, DÉLICTEUELLE OU AUTRE, OU DE TOUT ACTE OU OMISSION. LA RESPONSABILITÉ TOTALE DE LGECI, LE CAS ÉCHÉANT, N'OUTREPASSERA PAS LE PRIX D'ACHAT QUE VOUS AVEZ PAYÉ POUR LE PRODUIT.

Cette garantie limitée vous donne des droits légaux spécifiques. Vous pouvez également avoir d'autres droits qui varient d'une province à l'autre selon les lois provinciales applicables. Tout terme de cette

garantie limitée qui nie ou modifie toute condition ou garantie implicite en vertu de la loi provinciale est divisible lorsqu'elle est en conflit avec cette loi provinciale sans affecter le reste des termes de cette garantie.

LA PRÉSENTE GARANTIE LIMITÉE NE COUVRE PAS CE QUI SUIT :

- Les déplacements de service pour i) livrer, ramasser ou installer le produit, ou en expliquer le fonctionnement; ii) corriger le câblage; ou iii) corriger des réparations ou une installation non autorisées du produit;
- Le bris ou le dysfonctionnement du produit durant une panne, une interruption de l'alimentation électrique ou une mauvaise alimentation en électricité;
- Les dommages ou les défaillances causés par des conduites d'eau qui fuient ou qui sont brisées, des conduites d'eau gelées, des conduites de drainage obstruées, une alimentation en eau inadéquate ou interrompue ou un apport d'air insuffisant;
- Les dommages ou les défaillances attribuables à l'utilisation du produit dans un milieu agressif ou à un usage contraire aux instructions du manuel d'utilisation;
- Les dommages ou les défaillances causés par des accidents, des insectes nuisibles ou de la vermine, ou attribuables à la foudre, au vent, à un incendie, à une inondation ou à une catastrophe naturelle, ou toute autre cause indépendante de la volonté de LGECI ou du fabricant;
- Les dommages ou les défaillances résultant d'une mauvaise utilisation, d'un abus, d'une installation inadéquate, d'une mauvaise réparation ou d'un entretien inadéquat du produit. Une réparation incorrecte comprend l'utilisation de pièces non approuvées ou non spécifiées par LGECI. L'installation ou l'entretien inadéquats comprennent une installation ou un entretien contraires aux instructions du manuel d'utilisation;
- Dommage ou panne en raison de modification ou altération non autorisée du Produit, ou si utilisé pour fins autres que celle d'appareil ménager domestique, ou dommage ou panne résultant de toute fuite d'eau due à une mauvaise installation du produit;
- Les dommages ou les défaillances causés par un courant électrique, une tension ou des codes de plomberie incorrects;
- Les dommages ou les défaillances causés par un usage autre qu'une utilisation domestique normale, y compris, mais sans s'y limiter, une utilisation commerciale ou industrielle, y compris dans des bureaux commerciaux ou dans des installations récréatives, ou de toute autre façon décrite dans le manuel d'utilisation;
- Les dommages ou les défaillances causés par l'utilisation d'accessoires, de composants ou de produits de nettoyage qui ne sont pas approuvés ou autorisés par LGECI;
- Les dommages ou les défaillances causés par le transport et la manutention, y compris les rayures, les bosses, les entailles ou autres dommages à la finition du produit, à moins que ces dommages résultent de défauts de pièce ou de main-d'œuvre et soient rapportés à LGECI dans la première semaine suivant la livraison du produit;
- Les dommages ou les éléments manquants de tout affichage, boîte ouverte, produit remis à neuf ou produit en rabais;
- Le produit remis à neuf ou tout autre produit vendu « tel quel », « tel que disponible », « avec tous les défauts » ou tout avis de non-responsabilité semblable;
- Des produits dont le numéro de série original a été retiré, modifié ou ne peut être facilement déterminé à la discrétion de LGECI;
- L'augmentation des coûts des services publics et les dépenses supplémentaires connexes associées de quelque façon que ce soit au produit;
- Le remplacement des ampoules, des filtres, des fusibles ou de tout article consommable.
- Les coûts associés au retrait et à la réinstallation du produit aux fins de réparation;
- Les bruits liés au fonctionnement normal, le non-respect des directives du manuel d'utilisation, d'entretien ou d'installation de même que l'utilisation de l'appareil dans un environnement inadéquat ne sont pas couverts par cette garantie.

- Couverture pour réparations à domicile, pour produit sous garantie, sera fournie si le Produit se trouve dans un rayon de 150 km du centre de service autorisé (ASC) le plus près, tel que déterminé par LG Canada. Si votre Produit est situé à l'extérieur du rayon de 150 km d'un centre de service autorisé, tel que déterminé par LG Canada, il en ira de votre responsabilité d'apporter votre Produit, à vos frais, au centre de service (ASC) pour réparation sous garantie.

Tous coûts et dépenses associés aux circonstances exclues ci-dessus, énumérés sous la rubrique "Cette garantie limitée ne couvre pas" sont à la charge du consommateur.

AFIN D'OBTENIR SOUTIEN DE GARANTIE ET INFORMATIONS SUPPLÉMENTAIRES VEUILLEZ NOUS APPELER OU VISITER NOTRE SITE WEB :

Composez le 1 888 542-2623 et sélectionnez une option dans le menu ou visitez notre site Web au <http://www.lg.com>.

PROCÉDURE DE RÈGLEMENT DE DIFFÉREND :

SAUF LA OÙ LA LOI L'INTERDIT, TOUT DIFFÉREND ENTRE VOUS ET LG ASSOCIÉ DE QUELQUE FAÇON QUE CE SOIT À LA PRÉSENTE GARANTIE LIMITÉE SE RÈGLE EXCLUSIVEMENT PAR ARBITRAGE EXÉCUTOIRE PLUTÔT QUE DEVANT UN TRIBUNAL DE DROIT COMMUN. SAUF LA OÙ LA LOI L'INTERDIT, VOUS ET LG RENONCEZ IRRÉVOCABLEMENT À TOUT DROIT À UN PROCÈS DEVANT JURY, AINSI QU'À EXERCER UN RECOURS COLLECTIF OU À Y PARTICIPER.

Définitions. Aux fins du présent article, « LG » désigne LG Electronics Canada Inc., ses sociétés mères, ses filiales et ses sociétés affiliées et tous leurs dirigeants, administrateurs, employés, agents, bénéficiaires, détenteurs précédents des mêmes droits, successeurs, cessionnaires et fournisseurs; « différend » et « réclamation » englobent tout différend, réclamation ou litige de quelque sorte que ce soit (fondés sur une responsabilité contractuelle, délictuelle, légale, réglementaire ou découlant d'une ordonnance, par fraude, fausse représentation ou sous quelque régime de responsabilité que ce soit) découlant de quelque façon que ce soit de la vente, des conditions ou de l'exécution du produit ou de la présente Garantie limitée.

Avis de différend. Si vous prévoyez engager une procédure d'arbitrage, vous devez d'abord envoyer à LG un préavis écrit d'au moins 30 jours à l'adresse suivante : Équipe juridique LGECI, 20 Norelco Drive, North York, Ontario, Canada M9L 2X6 (l'« avis de différend »). Vous et LG convenez de discuter en toute bonne foi pour tenter de régler le différend à l'amiable. L'avis doit mentionner votre nom, votre adresse, votre numéro de téléphone, le produit faisant l'objet de la réclamation, la nature de la réclamation et la réparation demandée. Si vous et LG ne parvenez pas à régler le différend dans les 30 jours suivant la réception de l'avis de différend par LG, le différend doit être réglé par arbitrage exécutoire conformément à la procédure établie aux présentes. Vous et LG convenez que, tout au long du processus d'arbitrage, les modalités (y compris les montants) de toute offre de règlement formulée par vous ou par LG ne seront pas divulguées à l'arbitre et resteront confidentielles à moins d'accord contraire entre les deux parties ou que l'arbitre règle le différend.

Entente d'arbitrage exécutoire et renonciation à un recours collectif. Si la réclamation n'a pu être réglée dans les 30 jours suivant la réception de l'avis de différend par LG, vous et LG convenez de ne régler les réclamations vous opposant que par arbitrage exécutoire au cas par cas, à moins que vous vous prévaliez de l'option de retrait évoquée plus haut ou que vous résidiez dans un territoire de compétences qui interdit la pleine application de cette clause dans le cas de réclamations de ce type (Dans lequel cas, si vous êtes un consommateur, cette clause ne s'appliquera que si vous acceptez expressément l'arbitrage). Dans la mesure où la loi en vigueur le permet, aucun différend entre vous et LG ne peut être combiné ou regroupé avec un différend faisant intervenir le produit ou la réclamation d'une personne ou entité tierce. Plus précisément et sans limiter la portée de ce qui précède, sauf dans la mesure où une telle interdiction n'est pas autorisée en droit, en aucun cas un différend entre vous et LG ne peut être traité dans le cadre d'un recours collectif. Au lieu de l'arbitrage, les parties peuvent tenter une action individuelle devant une cour des petites créances, mais cette action ne peut pas être intentée dans le cadre d'un recours collectif, sauf dans la mesure où une telle interdiction n'est pas autorisée en droit dans votre province ou territoire de compétences pour une réclamation en cause qui nous oppose.

Règles et procédures d'arbitrage. Pour soumettre une réclamation à un arbitrage, l'une des deux parties, soit vous ou LG, doit déposer une demande écrite à cet effet. L'arbitrage est privé et confidentiel et s'effectue selon une procédure simplifiée et accélérée devant un arbitre unique choisi par les parties conformément aux lois et règlements en vigueur portant sur l'arbitrage commercial de votre province ou territoire de résidence. Vous devez également envoyer une copie de votre demande écrite à LG Electronics

Canada Inc., Legal Department - Arbitration, 20 Norelco Drive, North York, Ontario M9L 2X6. La présente disposition sur l'arbitrage est régie par les lois et règlements sur l'arbitrage commercial applicables de votre province ou territoire. La sentence arbitrale peut donner lieu à un jugement de n'importe quel tribunal compétent. Toutes les décisions relèvent de l'arbitre, à l'exception des questions associées à la portée et à l'applicabilité de la disposition sur l'arbitrage et à l'arbitrabilité du différend, qui sont du ressort du tribunal. L'arbitre est tenu de respecter les modalités de la présente disposition.

Droit applicable. Les lois de votre province ou territoire de l'achat régissent la présente Garantie limitée et tout différend entre nous, sauf dans la mesure où de telles lois sont supplantées par des lois fédérales, provinciales ou territoriales applicables ou sont incompatibles avec ces dernières. Si l'arbitrage n'est pas autorisé pour régler une réclamation, une poursuite, un différend ou un litige nous opposant, nous nous en remettons à la compétence exclusive des tribunaux de votre province ou territoire de l'achat pour le règlement de la réclamation, de la poursuite, du différend ou du litige nous opposant.

Frais et coûts. Aucuns frais ne sont exigibles pour entamer une procédure d'arbitrage. À la réception de votre demande d'arbitrage écrite, LG réglera rapidement la totalité des frais de dépôt de la demande d'arbitrage, sauf si vous réclamez des dommages-intérêts supérieurs à 25 000 \$. Dans ce cas, le paiement de ces frais sera régi par les règles d'arbitrage applicables. Sauf disposition contraire aux présentes, LG paiera tous les frais de dépôt de demande et d'administration ainsi que les honoraires de l'arbitre conformément aux règles d'arbitrage applicables et à la présente disposition sur l'arbitrage. Si vous remportez l'arbitrage, LG réglera vos frais et honoraires juridiques après avoir déterminé s'ils sont raisonnables en se fondant sur des facteurs comme, entre autres, le montant de l'achat et le montant de la réclamation. Si l'arbitre juge que le motif de la réclamation ou les réparations demandées sont futiles ou se fondent sur des motifs déplacés (au regard des lois applicables), le paiement de tous les frais d'arbitrage sera régi par les règles d'arbitrage applicables. Dans un tel cas, vous acceptez de rembourser à LG la totalité des montants versés qu'il vous revient autrement de payer en vertu des règles d'arbitrage applicables. Sauf disposition contraire et si elle remporte l'arbitrage, LG renonce à tous ses droits de vous réclamer des frais et honoraires juridiques.

Audience et lieu de l'arbitrage. Si votre réclamation est égale ou inférieure à 25 000 \$, vous pouvez opter pour un arbitrage conduit selon l'une des modalités suivantes uniquement : 1) sur examen des documents remis à l'arbitre, 2) par audience téléphonique ou 3) par audience en personne selon les dispositions des règles d'arbitrage applicables. Si votre réclamation dépasse 25 000 \$, le droit à une audience sera défini par les règles d'arbitrage applicables. Les audiences arbitrales en personne se tiendront à l'endroit le plus proche et le plus pratique pour les deux parties situé dans votre province ou votre territoire de résidence, sauf si nous convenons mutuellement d'un autre lieu ou d'un arbitrage par téléphone.

Dissociabilité et renoncement. Si une partie de la présente Garantie limitée (y compris les présentes procédures d'arbitrage) n'est pas applicable, les dispositions restantes demeurent en vigueur dans la mesure permise par la loi applicable. Le fait de ne pas exiger la stricte exécution d'une disposition de la présente Garantie limitée (y compris les présentes procédures d'arbitrage) ne signifie pas que nous ayons renoncé ni que nous ayons l'intention de renoncer à toute disposition ou partie de la présente Garantie limitée.

Option de retrait. Vous pouvez vous retirer de la présente procédure de règlement de différend. Dans ce cas, ni vous ni LG ne pouvez imposer à l'autre partie de participer à une procédure d'arbitrage. Pour vous prévaloir de l'option de retrait, vous devez envoyer un préavis à LG dans les trente (30) jours civils à compter de la date de l'achat du produit par le premier acheteur i) dans un courriel adressé à optout@lge.com et dont la ligne d'objet porte la mention « Retrait de l'arbitrage » ou ii) en composant le 1-800-980-2973. Que ce soit par courriel ou par téléphone, vous devrez donner a) votre nom et votre adresse; b) la date d'achat du produit; c) le nom ou le numéro de modèle du produit et d) le numéro de série [qu'il est possible de trouver i) sur le produit ou ii) en ligne au https://www.lg.com/ca_fr/soutien/reparation-garantie/demande-reparation, Trouver mes numéros de modèle et de série].

Si vous vous prévaliez de l'option de retrait, les lois de votre province ou territoire de résidence régissent la présente Garantie limitée et tout différend entre nous, sauf dans la mesure où de telles lois sont supplantées par des lois fédérales, provinciales ou territoriales applicables ou sont incompatibles avec ces dernières. Si l'arbitrage n'est pas autorisé pour régler une réclamation, une poursuite, un différend ou un litige nous opposant, nous nous en remettons à la compétence exclusive des tribunaux de votre province ou territoire de compétence pour le règlement de la réclamation, de la poursuite, du différend ou du litige nous opposant.

Vous ne pouvez vous prévaloir de l'option de retrait que de la manière décrite plus haut (c'est-à-dire par courriel ou par téléphone). Aucun autre type d'avis ne sera pris en compte pour le retrait de la présente

procédure de règlement de différend. Le fait de se retirer de la présente procédure de règlement de différend ne compromet d'aucune façon la protection accordée en vertu de la Garantie limitée, et vous continuerez à jouir de tous les avantages prévus par la Garantie limitée. Si vous conservez ce produit sans vous prévaloir de l'option de retrait, vous acceptez les conditions générales de la disposition sur l'arbitrage énoncée ci-dessus.

Conflit de modalités. En cas de conflit ou d'incompatibilité entre les modalités de la présente garantie limitée et le contrat de licence d'utilisation (CLU) en ce qui concerne le règlement des différends, les modalités de la présente garantie limitée contrôlent et régissent les droits et obligations des parties et ont préséance sur le CLU.



LG Customer Information Center

For inquiries or comments,
visit www.lg.com or call:

1-800-243-0000 U.S.A.

1-888-542-2623 CANADA

Register your product Online!

www.lg.com



ENGLISH

ESPAÑOL

OWNER'S MANUAL

WASHING MACHINE

Please read this owner's manual thoroughly before operating and keep it handy for reference at all times.

WD100C*

WD200C*

WD205C*



MFL68267005

www.lg.com

TABLE OF CONTENTS

3 IMPORTANT SAFETY INSTRUCTIONS

- 3 Basic Safety Precautions
- 4 Grounding Requirements
- 5 Safety Instructions for Installation
- 6 Safety Instructions for Use, Care, Cleaning and Disposal

7 FEATURES AND BENEFITS

- 7 Key Parts and Components
- 7 Included Accessories
- 7 Required Accessories

8 INSTALLATION INSTRUCTIONS

- 8 Choose the Proper Location
- 8 Power Outlet
- 8 Flooring
- 9 Unpacking and Removing Shipping Material
- 10 Overview of Connections
- 11 Connecting the Water Lines
- 12 Connecting the Drain Hose
- 12 Using The Drain Connector
- 13 Leveling the Washing Machine
- 14 Connecting to the Power Supply
- 15 Sorting Wash Loads
- 16 Detergent and Dispenser Use

17 HOW TO USE

- 17 Control Panel Features
- 18 Time and Status Display
- 19 Operating the Washer
- 20 Cycle Guide
- 20 Wash Cycles
- 21 Options
 - 21 Warm Water
 - 21 Extra Rinse
 - 21 Child Lock

22 CARE AND CLEANING

- 22 Regular Cleaning
 - 22 Cleaning the Exterior
 - 22 Care and Cleaning of the Interior
 - 22 Tub Clean Cycle
 - 22 Removing Mineral Buildup
 - 22 Leave the Lid Open

- 23 Maintenance

24 SPECIFICATIONS

24 SMART DIAGNOSIS™ SYSTEM

25 TROUBLESHOOTING

- 25 Faqs: Frequently Asked Questions
- 26 Normal Sounds You May Hear
- 26 Before Calling for Service
- 30 Error Codes

32 WARRANTY

IMPORTANT SAFETY INSTRUCTIONS

SAFETY MESSAGES

For your safety, the information in this manual must be followed to minimize the risk of fire, explosion, or electric shock, or to prevent property damage, injury to persons, or death. Your safety and the safety of others is very important. There are many important safety messages in this manual and on your appliance. Always read and obey all safety messages.



This is the safety alert symbol. This symbol alerts you to potential hazards that can result in property damage and/or serious bodily harm or death.

All safety messages will follow the safety alert symbol and either the word WARNING or CAUTION. These words mean:

⚠ WARNING You can be killed or seriously injured if you don't follow instructions.

⚠ CAUTION You may be slightly injured or cause damage to the product if you do not follow instructions.

All safety messages will tell you what the potential hazard is, tell you how to reduce the chance of injury, and tell you what can happen if the instructions are not followed.

BASIC SAFETY PRECAUTIONS

⚠ WARNING

To reduce the risk of fire, electric shock, or injury to persons when using this appliance, follow basic precautions, including the following.

- Use this appliance only for its intended purpose as described in this Owner's Manual.
- **Before use, the washer must be properly installed as described in this manual.**
- **Do not wash articles that have been previously cleaned in, washed in, soaked in, or spotted with gasoline, dry cleaning solvents, or other flammable or explosive substances, as they give off vapors that could ignite or explode.**
- **Do not add gasoline, dry cleaning solvents, or other flammable or explosive substances to the wash water.** These substances give off vapors that could ignite or explode.
- Under certain conditions, hydrogen gas may be produced in a hot water system that has not been used for 2 weeks or more. **HYDROGEN GAS IS EXPLOSIVE. If the hot water system has not been used for such a period, before using the washer, turn on all hot water faucets and let the water flow from each for several minutes.** This will release any accumulated hydrogen gas. As the gas is flammable, **do not smoke or use an open flame during this time.**
- **Do not allow children to play on or in the washer. Close supervision of children is necessary when the washer is used near children. A child might become trapped inside the washer and suffocate.**
- **Before the washer is removed from service or discarded, remove the lid to prevent children from climbing inside.**
- **Do not install or store the washer where it will be exposed to the weather or freezing temperatures.**
- **Do not tamper with controls.**
- Keep the area underneath and around your appliances free of combustible materials (lint, paper, rags, etc.), gasoline, chemicals and other flammable vapors and liquids.
- Service must be performed by a qualified service technician. **Do not disassemble the washer.**
- **See Installation Instructions for grounding requirements.**
- **WARNING :** This product contains chemicals known to the State of California to cause cancer and birth defects or other reproductive harm. ***Wash hands after handling.***
- **ALWAYS follow the fabric care instructions supplied by the garment manufacturer.**
- **Do not place items exposed to cooking oil in your washer.** Items contaminated with cooking oils may contribute to a chemical reaction that could cause a load to catch fire.

- **Use fabric softeners or products to eliminate static only as recommended by the manufacturer.**
- This washer is not designed for maritime use or for mobile installations such as in RVs, aircraft, etc.
- **Turn off the water faucets and unplug the washer if the machine is to be left for an extended period of time, such as during vacations.**
- **Do not use to dry articles containing foam rubber or similarly textured rubber-like materials.**
- Packaging material can be dangerous for children. There is a risk of suffocation! Keep all packaging from children.
- **Always check the inside of the washer for foreign objects before loading laundry. Keep the lid closed when not in use.**
- **Do not reach into the appliance if the tub or agitator is moving.**
- **In the event of a gas leak (such as propane gas, LP gas, etc.), ventilate the area immediately. Do not turn any appliance or light on or off. Do not use a ventilating fan. A spark may result in an explosion or fire.**
- **Do not repair or replace any part of the appliance or attempt any servicing unless specifically recommended in the user-maintenance instructions or in published user-repair instructions that you understand and have the skills to carry out.**

READ ALL INSTRUCTIONS BEFORE USE

WARNING

For your safety, the information in this manual must be followed to minimize the risk of fire, explosion or electric shock, or to prevent property damage, injury to persons, or death.

GROUNDING REQUIREMENTS

This appliance must be grounded. In the event of malfunction or breakdown, grounding will reduce the risk of electric shock by providing a path of least resistance for electric current. This appliance is equipped with a cord having an equipment-grounding conductor and grounding plug. The plug must be plugged into an appropriate outlet that is properly installed and grounded in accordance with all local codes and ordinances. CERTAIN INTERNAL PARTS ARE INTENTIONALLY NOT GROUNDED AND MAY PRESENT A RISK OF ELECTRIC SHOCK ONLY DURING SERVICING. SERVICE PERSONNEL - DO NOT CONTACT THE FOLLOWING PARTS WHILE THE APPLIANCE IS ENERGIZED: PUMP, VALVE, MOTOR, CONTROL.

WARNING

Improper connection of the equipment-grounding conductor can result in risk of electric shock. Check with a qualified electrician or servicer if you are in doubt as to whether the appliance is properly grounded. Do not modify the plug provided with the appliance. If it does not fit the outlet, have a proper outlet installed by a qualified electrician. Failure to follow these warnings can cause serious injury, fire, electric shock, or death.

WARNING

For your safety, the information in this manual must be followed to minimize the risk of fire, explosion, or electric shock, or to prevent property damage, injury to persons, or death.

SAFETY INSTRUCTIONS FOR INSTALLATION

WARNING

To reduce the risk of fire, electric shock or injury to persons when using this appliance, follow basic precautions, including the following:

- **Refer to INSTALLATION INSTRUCTIONS for detailed grounding procedures.** Installation instructions are packed with the washer for installer's reference. If the washer is moved to a new location, have it checked and reinstalled by a qualified service technician. Failure to follow this warning can cause serious injury, fire, electric shock, or death.
- **The power cord of this appliance is equipped with a 3-prong (grounding) plug which mates with a standard 3-prong (grounding) wall outlet** to minimize the possibility of electric shock from this appliance.
- **Do not, under any circumstances, cut or remove the third (ground) prong from the power cord.** Failure to follow this warning can cause serious injury, fire, electric shock, or death.
- **For personal safety, this appliance must be properly grounded.** Failure to follow this warning can cause serious injury, fire, electric shock, or death.
- **This washer must be plugged into a 120 VAC, 60 Hz grounded outlet.** Failure to follow this warning can cause serious injury, fire, electric shock, or death.
- **Have the wall outlet and circuit checked by a qualified electrician to make sure the outlet is properly grounded.** Failure to follow this warning can cause serious injury, fire, electric shock, or death.
- **Where a standard 2-prong wall outlet is encountered, it is your personal responsibility and obligation to have it replaced with a properly grounded 3-prong wall outlet.** Failure to follow this warning can cause serious injury, fire, electric shock, or death.
- **Do not install on carpet. Install washer on a solid floor.** Failure to follow this warning can cause serious leak damage.
- **The washer should always be plugged into its own individual electrical outlet which has a voltage rating that matches the rating plate.** This provides the best performance and also prevents overloading house wiring circuits which could cause a fire hazard from overheated wires.
- **If installing the pedestal washer with an LG front-loading washer and an LG gas dryer, and insufficient outlets are available, an extension cord rated at no less than the branch circuit may be used.**
- **Never unplug your washer by pulling on the power cord.** Always grip plug firmly and pull straight out from the outlet. Failure to follow this warning can cause serious injury, fire, electric shock, or death.
- **Repair or immediately replace all power cords that have become frayed or otherwise damaged. Do not use a cord that shows cracks or abrasion damage along its length or at either end.** Failure to follow this warning can cause serious injury, fire, electric shock, or death.
- **When installing or moving the washer, be careful not to pinch, crush, or damage the power cord.** Failure to follow this warning can cause serious injury, fire, electric shock, or death.
- **The washer must be installed and electrically grounded by a qualified service person in accordance with local codes** to prevent shock hazard and assure stability during operation.
- **The washer is heavy. Two or more people may be needed to install and move the appliance.** Failure to do so can result in back or other injury.
- **Store and install the washer where it will not be exposed to temperatures below freezing or exposed to outdoor weather conditions.** Failure to follow this warning can cause serious leak damage.
- **To reduce the risk of electric shock, do not install the washer in humid spaces.** Failure to follow this warning can cause serious injury, fire, electric shock, or death.
- **To reduce the risk of injury to persons, adhere to all industry recommended safety procedures including the use of long sleeved gloves and safety glasses.** Failure to follow all of the safety warnings in this manual could result in property damage, injury to persons or death.
- **Never attempt to operate this appliance if it is damaged, malfunctioning, partially disassembled, or has missing or broken parts, including a damaged cord or plug.**
- **To minimize the possibility of electric shock, unplug this appliance from the power supply or disconnect the washer at the household distribution panel by removing the fuse or switching off the circuit breaker before attempting any maintenance or cleaning.**
- **Plug the power plug into the wall socket in the right direction so that the cord runs towards the floor.** If you plug the power plug into the socket in the opposite direction, the electric wires within the cable may be damaged and this may result in electric shock or fire.

- The pedestal washer is for installation and use only underneath an LG manufactured front-loading washer. The pedestal washer is not designed to operate as a standalone unit, under an LG top-loading washer, under a dryer, or under a non-LG manufactured washer.
- Do not tamper with the stacking switch. Doing so may cause machine malfunctions or serious injury.
- Do not operate the pedestal washer with two or more pedestal washers stacked. Doing so may cause machine malfunctions or serious injury.

WARNING

For your safety, the information in this manual must be followed to minimize the risk of fire, explosion, or electric shock, or to prevent property damage, injury to persons, or death.

SAFETY INSTRUCTIONS FOR USE, CARE, CLEANING AND DISPOSAL

WARNING

To reduce the risk of fire, electric shock or injury to persons when using this appliance, follow basic precautions, including the following:

- **Unplug the washer before cleaning** to avoid the risk of electric shock.
- **Never use harsh chemicals, abrasive cleaners, or solvents to clean the washer.** They will damage the finish.
- **Do not put oily or greasy rags or clothing on top of the washer.** These substances give off vapors that could ignite the materials.
- **Do not wash items that are soiled with vegetable or cooking oil.** These items may contain some oil after laundering. Due to the remaining oil, the fabric may smoke or catch fire by itself.
- **Disconnect this appliance from the power supply before attempting any user maintenance.** Turning the controls to the OFF position does not disconnect this appliance from the power supply. Failure to follow this warning can cause serious injury, fire, electric shock, or death.
- **Do not combine laundry products for use in one load unless specified on the label.**
- **Do not mix chlorine bleach with ammonia or acids such as vinegar.** Follow package directions when using laundry products. Incorrect usage can produce poisonous gas, resulting in serious injury or death.
- **Do not reach into the washer while parts are moving.** Before loading, unloading, or adding items, press the START/PAUSE button and allow the drum to coast to a complete stop before reaching inside. Failure to follow this warning can cause serious injury, fire, electric shock, or death.
- **Do not allow children to play on or in the washer.** Close supervision of children is necessary when the washer is used near children. As children grow, teach them the proper, safe use of all appliances. Failure to comply with these warnings could result in serious injury to persons or death.
- **Destroy the carton, plastic bag, and other packing materials after the washer is unpacked.** Children might use them for play. Cartons covered with rugs, bedspreads, or plastic sheets can become airtight chambers. Failure to comply with these warnings could result in serious injury to persons or death.
- **Keep laundry products out of children's reach.** To prevent injury to persons, observe all warnings on product labels. Failure to comply with these warnings could result in serious injury to persons or death.
- **Remove the lid to the washing compartment before your washer is removed from service or discarded to avoid the danger of children or small animals getting trapped inside.** Failure to do so can result in serious injury to persons or death.
- **Keep hands and foreign objects clear of the lid and latch area when closing the lid.** Failure to keep hands clear can result in personal injury.
- **Do not touch the power plug with wet hands.** This may result in electric shock.
- **Do not touch the water draining from the machine during a high-temperature wash or drying cycle.** This water is hot, and touching it may result in burns or injury.
- **Do not stand on top of the appliance or place objects (such as laundry, lighted candles, lighted cigarettes, dishes, chemicals, metal objects, etc.) on the appliance.** This may result in electric shock, fire, problems with the product, or injury.
- **Do not install or store the washer where it will be exposed to freezing temperatures.** Water may freeze in the hoses and damage the washer. Winterize the washer before storing or moving it in freezing temperatures. Refer to the Maintenance section for instructions.
- **To avoid breaking the lid glass, do not push too hard on the lid when closing.**
- **Do not step on the pedestal washer.** Doing so may damage the washer or cause serious injury.
- **Do not open or close the lid by foot.** Doing so may result in personal injury or damage to the product.

SAVE THESE INSTRUCTIONS

FEATURES AND BENEFITS

KEY PARTS AND COMPONENTS

Appearance and specifications may vary without notice to improve the quality of the product.

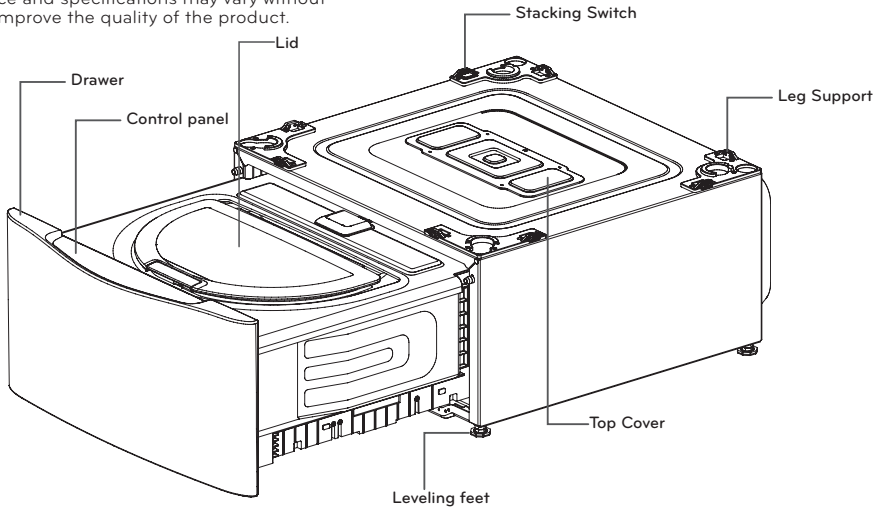

A INVERTER DIRECT DRIVE MOTOR

The inverter motor, which is directly connected to the tub, produces less noise and vibration while offering outstanding durability and a long lifespan.

B COMPACT CAPACITY & NEVERUST™ STAINLESS STEEL TUB

The efficient design provides capacity in a compact space.

C FRONT TOUCH PANEL











The simple LED display shows cycle options, setting, cycle status and estimated time remaining. The touch buttons offer more convenience and a premium design aesthetic.

D SMART DIAGNOSIS™

If you ever experience an issue with your LG washer, you don't have to worry. The SmartDiagnosis™ feature helps the service center diagnose problems over the phone, or with a simple app on your smart phone, helping you minimize costly, inconvenient service calls.

E REMOTE CONTROL RCW1

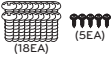
Don't want to bend down to reach the controls? Set cycles with the touch of a button on the available remote control. (Included accessory (model WD205C), or available for purchase online or through an LG retailer.)

INCLUDED ACCESSORY					REQUIRED ACCESSORY
					
2 Inlet Hoses-Short	2 Inlet Hose Y-Connectors	Drain Hose Y-Connector	Drain Hose	Non-Skid Pads	
					2 Inlet Hoses
Wrench	2 Tie Straps	2 Wire clamps and 1 Band clamp	Screws	Detergent Dispenser	

NOTE: Contact LG Customer Service at 1-800-243-0000 (1-888-542-2623 in Canada) if any accessories are missing or to purchase accessories. For a list of LG front-loading washers which are compatible with the pedestal washer, visit the LG website at www.lg.com/us/twinwash

INSTALLATION INSTRUCTIONS

CHOOSE THE PROPER LOCATION FLOORING

⚠ WARNING

- Two or more people are required when moving, unpacking, and stacking the washer. Failure to follow this warning may result in damage to property or serious bodily harm.
- Store and install the washer where it will not be exposed to weather or to temperatures below freezing. Failure to follow this warning can cause serious injury, fire, electric shock, or death.
- Properly ground the washer to conform with all electric governing codes and ordinances. Failure to follow this warning can cause serious injury, fire, electric shock, or death.
- To reduce the risk of electric shock, do not install the washer in humid spaces. Failure to follow this warning can cause serious injury, fire, electric shock, or death.
- To ensure proper air flow, do not block the large opening on the bottom of the washer with carpeting or other materials.
- Do not remove the ground prong. Do not use a 2-prong adapter or 2-wire extension cord. Failure to follow these warnings can cause serious injury, fire, electric shock, or death.

⚠ CAUTION

- This pedestal washer must be installed underneath a matching front-loading LG washing machine manufactured after 2009. (The 29" wide machine must be stacked under a 29" wide LG front-loading washer. The 27" wide machine must be stacked under a 27" wide LG front-loading washer.)
- The pedestal washer will not work as a standalone unit.
- The pedestal washer must be stacked under an LG brand appliance in order to operate properly.

POWER OUTLET

- The power outlet must be within 60 in. (1.5 m) of either side of the washer.
- The appliance and outlet must be positioned so that the plug is easily accessible.

⚠ WARNING

- For best performance, plug the washer into its own individual outlet. If necessary, use a new, UL-listed 3-prong adapter or 3-wire extension cord with a 3-prong (grounding) plug rated at no less than the branch circuit. Do not use an extension cord longer than three feet. Failure to follow these warnings can result in serious injury, fire, electric shock, or death
- The outlet must be grounded in accordance with current wiring electric codes and regulations.
- Time-delay fuse or circuit breaker is recommended.

NOTE: It is the personal responsibility and obligation of the product owner to have a proper outlet installed by a qualified service technician.

- To minimize noise and vibration, the washer **MUST** be installed on a solidly constructed floor.
- Allowable slope under the entire washer is a maximum 1 inch. difference from side to side or from front to back.
- Installing on carpeting and soft tile surfaces is not recommended.
- Never install the washer on a platform or weakly supported structure.

NOTE: The washer must be installed on firm flooring to minimize vibration during the spin cycle. Concrete flooring is best, but a wood floor is sufficient, provided it is built to FHA standards. The washer should not be installed on rugs or exposed to weather.

Do not use a drip pan as it can block the drawer. Using the drip pan may result in increased vibration and noise during operation.

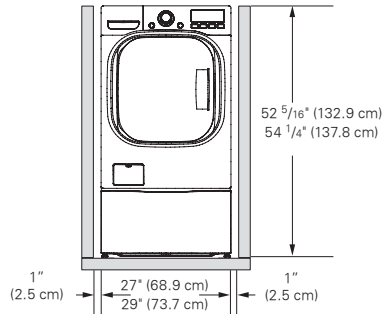

To ensure sufficient clearance for water lines and airflow, allow minimum clearances of at least 1 in. (2.5 cm) at the sides and 4 in. (10 cm) behind the unit. Be sure to allow for wall, door, or floor moldings that may increase the required clearances.

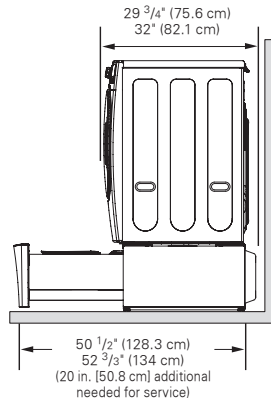

UNPACKING AND REMOVING SHIPPING MATERIAL

1. After removing the carton and shipping material, lift the washer off the foam base. Make sure the plastic tub support comes off with the base and is not stuck to the bottom of the washer.

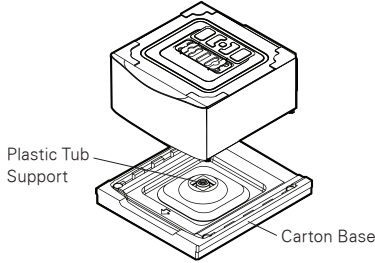

If you must lay the washer down to remove the base packaging materials, always protect the side of the washer and lay it carefully on its side. **DO NOT** lay the washer on its front or back.

2. Save the foam block for future use. If the washer must be moved in the future, the foam block will help prevent damage to the washer during transportation.

NOTE: To prevent damage, do not remove the foam block until the washer is at the final location.

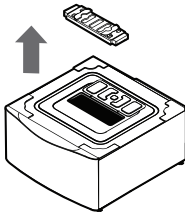

3. Turn the top cover about 180 degrees. Cover the upper hole with the top cover and install 4 short screws (included in packing box) to fix it in place.

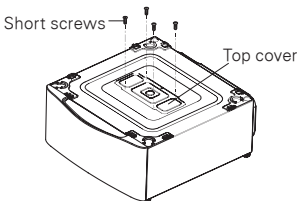

4. Make sure the leveling legs on the front-loading washer are fully retracted before stacking it on top of the pedestal washer. Position the appliance on top of the pedestal washer.

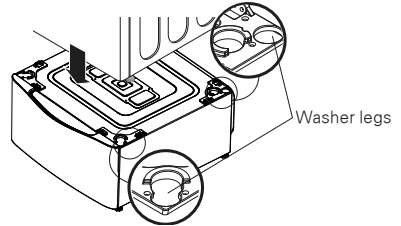

5. Make sure the holes on the pedestal washer align with the holes in the front-loading washer, then install 4 long screws (included in box) at each corner to securely attach the front-loading washer to the pedestal washer.

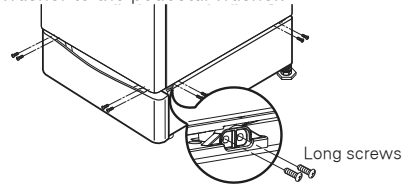

6. Extend the legs of the front-loading washer slightly until it is snugged up against the pedestal washer.

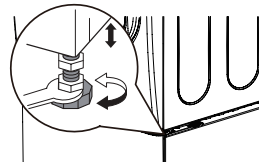

TOOLS YOU WILL NEED

- Adjustable Pliers
- Carpenter's Level

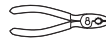

- Screwdriver

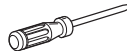

⚠ WARNING

- The top cover must be installed to avoid the risk of electric shock or short circuit. Failure to do so can cause serious injury, fire, electric shock or death.

OVERVIEW OF CONNECTIONS

CONNECTING THE WATER LINES WITH FULL-SIZE APPLIANCES

1. Front-loading washer and pedestal washer with dryer.

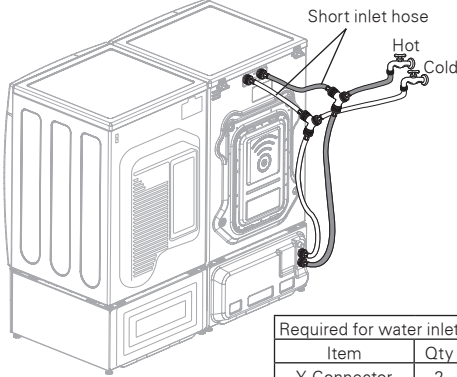

Required for water inlet	
Item	Qty
Y-Connector	2
Short inlet hose	2
Long inlet hose	4

long inlet hoses sold separately

2. Front-loading washer and pedestal washer with Turbo Steam dryer

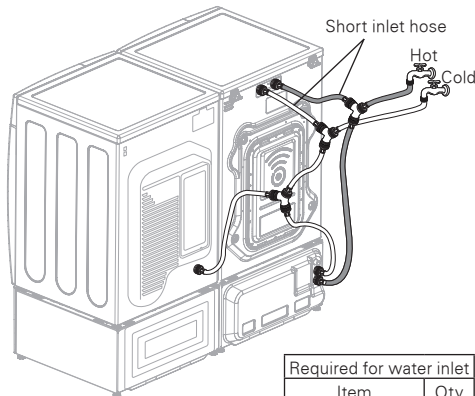

Required for water inlet	
Item	Qty
Y-Connector	3
Short inlet hose	3
Long inlet hose	5

long inlet hoses sold separately

CONNECTING THE DRAIN HOSE WITH FULL-SIZE WASHER

1. Front-loading washer and pedestal washer with dryer.

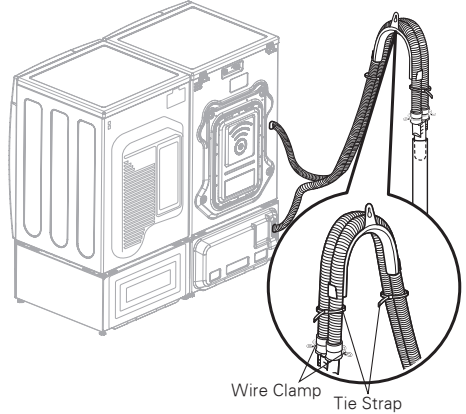

2. Front-loading washer and pedestal washer with hybrid dryer

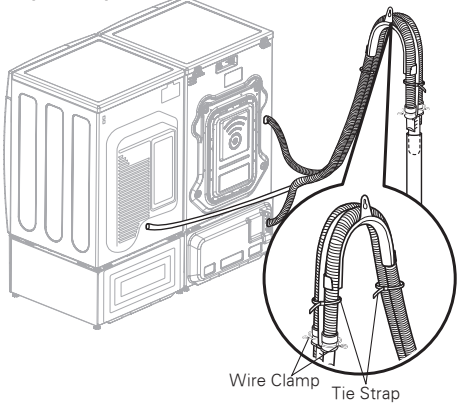

DETAIL VIEW OF DRAIN CONNECTOR CONNECTION

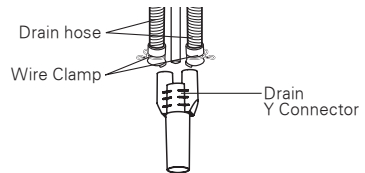

For narrow standpipes, insert hybrid dryer drain hose in center of drain connector. **DO NOT** insert dryer drain hose further than 1 inch (2.5 cm). Use tie straps to keep hoses in place.

CONNECTING THE WATER LINES

NOTE:

- For your safety, and for extended product life, use high-quality LG components. LG is not responsible for product malfunction or damage caused by the use of separately purchased non-LG parts.
- Do not reuse old hoses. Use only new hoses when installing the washing machine. Old hoses could leak or burst causing flooding and property damage. Contact LG Customer Service for assistance in buying hoses: 1-800-243-0000.
- Do not use flood-preventing hoses with auto shutoff devices. The devices can be tripped during fill and prevent the machine from filling properly.

1. Check the fittings and seals.

Inspect the threaded fitting on each hose and make sure there is a rubber seal in place in both ends of each hose to prevent leaking.

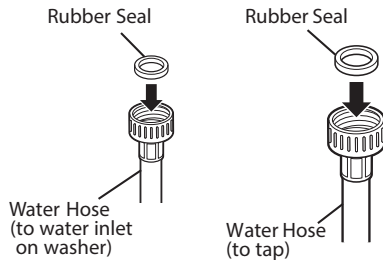

2. Connect the water supply hoses.

Connect the water supply hoses to the HOT and COLD water faucets tightly by hand and then tighten another 2/3 turn with pliers. Connect the blue hose to a cold water faucet and the red hose to a hot water faucet.

⚠ WARNING

- **Do not overtighten.** Damage to the coupling can result.

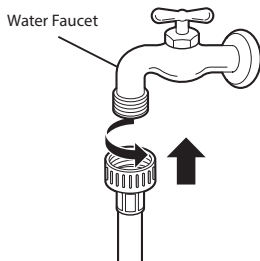

3. Flush out the inlet hoses.

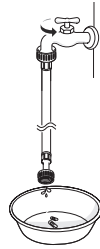

After connecting the inlet hoses to the water faucets, turn on the water faucets to flush out foreign substances (dirt, sand or sawdust) in the water lines. Let water drain into a bucket, and check the water temperature to make sure you've connected the hoses to the correct faucets.

4. Attach the water lines to the back of the washer.

Attach the hot water line to the provided inlet Y-connector and attach the short water line from the Y-connector to the full-size washer inlet. Then attach the long water line from the Y-connector to the pedestal washer inlet. Repeat with the cold water connections.

Tighten the fittings securely. Turn on both faucets all the way and check for leaks at both ends of the hoses.

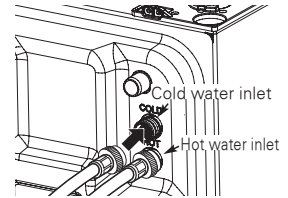

⚠ WARNING

- **Do not overtighten the hoses or crossthread the hose fittings.** Overtightening or cross-threading can damage the valves, resulting in leaking and property damage.

NOTE:

- Periodically check the hoses for cracks, leaks, and wear, and replace the hoses every five years. Do not stretch the water hoses intentionally, and make sure that they are not pinched, crushed or kinked by other objects.
- Water supply pressure must be between 20 psi and 120 psi (138–827 kPa). If the water supply pressure is more than 120 psi, a pressure reducing valve must be installed.
- To provide optimum washing performance, set the hot water temperature at 120°–135°F (48°–57°C) and the cold at 60°F (15°C).
- Never install or store the washer in a location subject to freezing temperatures. Damage to the water lines and internal mechanisms of the washer can result. If the washer was exposed to freezing temperatures prior to installation, allow it to stand at room temperature for several hours before use and check for leaks prior to operation.

CONNECTING THE DRAIN HOSE

- The drain hose should always be properly secured. Failure to properly secure the drain hose can result in flooding and property damage.
- The drain must be installed in accordance with any applicable local codes and regulations.
- Make sure that the drain hose is not stretched, pinched, crushed, or kinked.

CONNECTING THE PEDESTAL WASHER DRAIN HOSE

1. Insert the band clamp (included in packing box) on to the drain hose elbow.

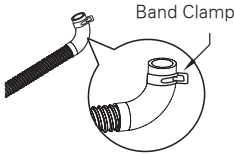

2. With the hose leading up from the elbow, insert the elbow onto the drain outlet on the back of the pedestal washer.

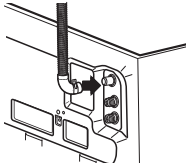

3. Adjust the band clamp with pliers to keep the hose securely in place and prevent leaking.

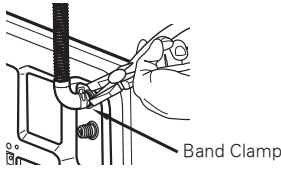

USING THE DRAIN CONNECTOR

- Connect the drain hose of the full-size washer and the pedestal washer to the drain connector. Insert the included wire hose clamps on to the ends of the two drain hoses. Push the drain hoses firmly onto the drain connector. Adjust the wire hose clamps to prevent the hoses from coming loose or leaking. Failure to do so could result in flooding. Use of the drain connector helps avoid siphoning, odors, or improper draining.

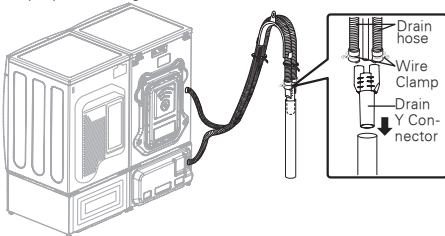

OPTION 1: STANDPIPE

Bend the outlet end of the drain hoses to form a U shape. Insert the end of the drain connector into the drain. Use the three tie straps included with the installation materials in the foam block in the tub to secure the drain hoses to each other and to the drain. See Overview of Connections for details. If your drain is a standpipe, fasten the drain hoses to the standpipe with the tie strap provided.

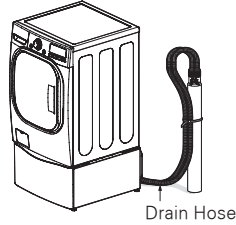

NOTE:

- Normal height of the end of the hoses should be approximately 35"~47" (90~120 cm) from the floor.
- Do not install the end of the drain hoses lower than 29". (73.7 cm) or higher than 96 in. (243.8 cm) above the bottom of the washer or more than 60 in. (152.4 cm) away from the washer.
- Never create an airtight seal between the hoses and the drain with tape or other means. If no air gap is present, water can be siphoned out of the tub resulting in poor wash/rinse performance or clothing damage.
- For best performance, if there is an additional drain hose from a hybrid dryer, place the drain hose in the standpipe next to the drain connector.
- If the standpipe is too narrow to fit both the drain connector and the dryer drain hose, the dryer drain hose may be inserted up to 3/4 in. into the center channel of the drain connector. See Overview of Connections, page 10.

⚠ CAUTION

- Inserting the dryer drain hose farther than 3/4 in. will cause leaking and improper draining.

OPTION 2: LAUNDRY TUB

Bend the end of the drain hoses to the desired shape and support them on the edge of the laundry tub. Use the tie strap to secure the drain hoses in place.

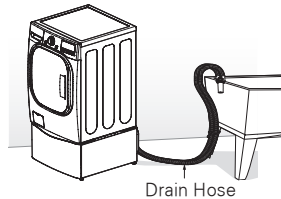

NOTE:

- Do not use this drain hose with a floor drain. The end of the drain hose must be at least 29 inches above the floor for proper draining to occur.

LEVELING THE WASHING MACHINE

The washer tub of your new washing machine spins at very high speeds. To minimize vibration, noise, and unwanted movement, the floor must be perfectly level and solid.

- Check that the washing machine is level.
 - Check for levelness by rocking the top edges of the washing machine or placing a level on the washing machine. The slope beneath the washing machine must not exceed 1/2°, and all four leveling feet must rest firmly on the floor.

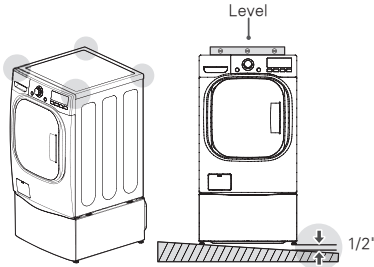

- Turn the lower leveling feet clockwise to level the washing machine.
 - Turning the lower leveling feet clockwise raises the washing machine.

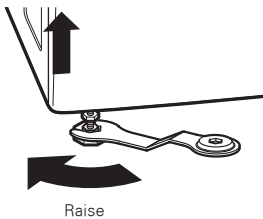

- Turn the locknuts counterclockwise and tighten them when the washing machine is level.

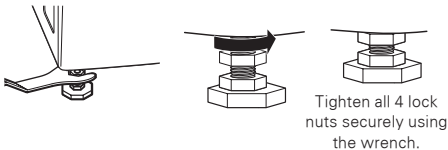

- Check again that the washing machine is level.
 - Push or rock the top edges of the washing machine gently to make sure that the washing machine does not rock.
 - If the washing machine rocks, repeat steps 1 to 3.

⚠ WARNING

- Using the washing machine without leveling may cause it to malfunction, producing excess vibration and noise.
- When stacking the full-size washing machine on the pedestal washer, use the leveling feet on the pedestal washer to level both. The full-size washing machine's leveling feet should be minimized and the locknuts turned counterclockwise to secure them.
- **Use the leveling feet only when you level the washing machine.** If you raise the leveling feet unnecessarily, it may cause abnormal vibration of the washing machine.

USING NON-SKID PADS (OPTIONAL)

If you install the washing machine on a slippery surface, it may move because of excessive vibration. Incorrect leveling may cause malfunction through noise and vibration. If this occurs, lay the non-skid pads under the leveling feet and adjust the level.

- Clean the floor to attach the non-skid pads.
 - Use a dry rag to remove foreign objects or moisture. If moisture remains, the non-skid pads may slip.
- Adjust the level after placing the washing machine in the installation area.
- Place the adhesive side of the non-skid pad on the floor.
 - It is most effective to install the non-skid pads under the front legs. If it is hard to place the pads under the front legs, place them under the back legs.

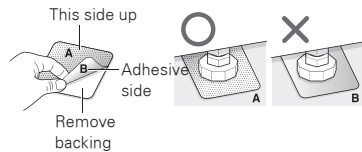

- Check again that the washing machine is level.
 - Push or rock the top edges of the washing machine gently to make sure that the washing machine does not rock. If the washing machine rocks, level the washing machine again.

CONNECTING TO THE POWER SUPPLY

The washer should be plugged into a 120 VAC, 60 Hz, 3-prong (grounded) outlet. Plug in the washer.

⚠ WARNING

- Improper connection of the equipment grounding conductor can result in risk of electric shock. Check with a qualified electrician or service technician if there is doubt that the outlet is properly grounded. Do not modify the plug provided with the appliance. Never damage or cut off the ground prong of the power cord. If the cord does not fit the outlet, have a proper outlet installed by a qualified electrician. Failure to follow these warnings can result in serious injury, fire, electric shock, or death.

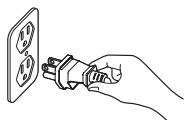

⚠ WARNING

- The power outlet must be within 60 inches (1.5 m) of either side of the washer.
- The appliance and outlet must be positioned so that the plug is easily accessible.
- Plug the washer into an electrical outlet which has a voltage rating that matches the rating plate. For best performance, plug the washer into its own individual outlet. This helps prevent overloading house wiring circuits which could cause a fire hazard from overheated wires. If necessary, use a new, UL-listed 3-prong adapter or 3-wire extension cord with a 3-prong (grounding) plug rated at no less than the branch circuit. Do not use an extension cord longer than three feet. Failure to follow these warnings can cause serious injury, fire, electric shock, or death.
- The outlet must be grounded in accordance with current wiring codes and regulations.
- Time-delay fuse or circuit breaker is recommended.
- It is the personal responsibility and obligation of the product owner to have a proper outlet installed by a qualified electrician.
- Do not use a worn or damaged power cord or power plug. Replace or repair it immediately. Failure to do so may result in death, fire, electric shock, or malfunction.
- Do not modify the power cord and take care not to damage it when installing or moving the washing machine. Failure to do so may result in death, fire, electric shock, or malfunction.
- Make sure that the washing machine is grounded.
- Connect this washing machine to a grounded outlet conforming to the rating prior to use. Failure to do so may result in fire, electric shock, or malfunction.
- Do not damage or cut off the ground prong of the power cord. Doing so may cause death, fire, electric shock, or product malfunction.

SORTING WASH LOADS

⚠ CAUTION

- Do not load items higher than the top edge of the tub. Failure to follow this caution can result in leakage or damage to fabrics.
- Use the Bedding cycle in the full-size washer for buoyant or nonabsorbent items such as pillows or comforters. Refer to owner's manual included with washing machine. Failure to follow this caution can result in leakage.

GROUPING SIMILAR ITEMS

For the best washing results, and to reduce the possibility of damage to clothing, sort the clothing into loads that are made up of similar items.

Mixing different fabric types and/or soil levels can result in poor wash performance, color transfer, discoloration, fabric damage or linting. Sort fabrics into groups as described below.

COLORS

Sort articles by color. Wash dark clothes together in a separate load from light colors or whites. Mixing dark clothes with light clothes can result in dye transfer or discoloration of the lighter clothes.

SOIL LEVEL

Wash heavily soiled clothing in the full-sized washer. Washing lightly soiled clothing in the same load with heavily soiled clothing could result in poor wash performance for the lightly soiled clothing. The pedestal washer is optimized for use with lightly soiled and delicate items.

FABRIC TYPE

Do not mix delicate items with heavier or sturdier fabrics. Washing heavier fabrics in a delicate load can result in poor wash performance for the heavier fabrics and possible damage to the delicate items.

LINT TYPE

Some fabrics attract and bind lint to them while others give off lint in the laundry process. Avoid mixing these lint collectors and lint producers in the same load. Mixing these fabrics results in pilling and linting on the lint collectors. (For example, lint collector – knit sweater; lint producer – terry cloth towels.)

SORT LAUNDRY...

By Colors	By Soil	By Fabric	By Lint
White	Heavy	Delicates	Lint Producer
Lights	Normal	Easy Care	Line Collector
Darks	Light	Sturdy	

FABRIC CARE LABELS

Many articles of clothing include a fabric care label. Using the chart below, adjust the cycle and option selections to care for your clothing according to the manufacturer's recommendations.

Fabric Care Labels

Machine wash cycle



Normal



Permanent press/
wrinkle resistant



Gentle/
delicate



Hand wash



Do not wash



Do not wring

Water temperature



Hot



Warm



Cold/cool

Bleach symbols



Any bleach
(when needed)



Only non-chlorine bleach
(when needed)



Do not bleach

LOADING THE WASHER

- Check all pockets to make sure that they are empty. Items such as clips, matches, pens, coins, and keys can damage both the washer and the clothes.
- Close zippers, hooks, and drawstrings to prevent these items from snagging or tangling on other clothes.
- Pretreat heavily stained areas for best results.
- To prevent an out-of-balance load, do not wash single items. Add one or two similar items to the load. Large, bulky items, such as a blanket, comforter, or bedspread, should be washed individually in the full-size washer.
- The washer will not fill or operate with the lid open.
- Don't overload the tub. Clothes should fit loosely in the tub under the maximum fill line. Loading clothes over the fill line may result in damage to clothing and the washer.

⚠ CAUTION

- Close the lid until it clicks before sliding the drawer in to begin the cycle.
- Press to open the lid. Do not force the lid of the washing machine open. Doing so may damage the machine.

DETERGENT AND DISPENSER USE

A WORD ABOUT DETERGENTS

High-Efficiency (HE) detergents produce fewer suds, dissolve more efficiently to improve washing and rinsing performance, and help to keep the interior of your washer clean. Using detergent that is not HE may cause oversudsing and unsatisfactory performance which could result in error codes, cycle failure, and machine damage.

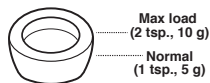

This machine requires very little detergent. For proper wash performance, always use the dispenser and measuring device provided with the machine.

The dispenser holds a maximum of 2 teaspoons (10g/10cc) of HE detergent. Most normal loads require only 1 teaspoon (5g/5cc) of detergent, or filling the dispenser to the halfway line.

Do not use a full detergent pod in the pedestal washer. Using too much detergent may cause oversudsing and unsatisfactory performance. Reduce detergent amount or add an extra rinse if detergent residue is left on fabrics. To add an extra rinse, press the Extra Rinse button.



DESIGNED TO USE ONLY HIGH-EFFICIENCY (HE) DETERGENT

IMPORTANT: Your washing machine is designed for use with only High-Efficiency (HE) detergents. HE detergents are formulated specifically for High-Efficiency washers and contain suds-reducing agents. Always look for the HE symbol when purchasing detergent.

IMPORTANT: Not all detergents are the same. Pay careful attention to the amount of detergent used to avoid oversudsing, poor rinsing and detergent buildup in clothing, and residue buildup that can contribute to odors in the machine. The maximum measure on the dispenser provided should only be used for very large loads. Using too much detergent can result in detergent buildup in the washer and in your clothes.

Always measure the detergent amount. While HE detergents are designed for this type of washing machine, be careful when measuring the detergent. For most normal loads, no more than 1 teaspoon or half the provided dispenser/measuring device of HE detergent should be used.

NOTE:

- Extra care must be exercised when using 2X and 3X concentrated detergents because even a little bit extra can contribute to the problems mentioned above.
- Detergents designated as HE compatible may not provide optimal results.

USING THE DETERGENT

1. Slide the drawer open, open the lid, and add the garments into the tub.
2. Measure the detergent with the detergent dispenser and pour it into the tub.
3. Close the lid, slide the drawer closed, and press the START/PAUSE button to start the cycle.

NOTE: Liquid chlorine bleach or powdered bleach cannot be used in the pedestal washer. To use bleach, use the full-size washer and follow instructions in the owner's manual for that machine.

IMPORTANT: Do not place or store laundry products, such as detergent, bleach, or liquid fabric softener, on top of your washer or dryer. Wipe up any spills immediately. These products can damage the finish and controls.

USING BLEACH

Do not use liquid chlorine bleach or powdered bleach in the pedestal washer. To bleach items, use the full-size washer and follow the instructions in the owner's manual included with that machine.

USING FABRIC SOFTENER

The pedestal washer chimes repeatedly before the final rinse so liquid fabric softener can be added to the load, if desired. Use 1/4 the amount of softener recommended by the manufacturer for a normal load.

When the machine chimes, press Start/Pause to pause the cycle.

1. Slide the drawer open, open the lid, and add the liquid fabric softener to the detergent dispenser. The softener can also be diluted with water and added directly into the tub. Do not pour undiluted softener directly onto clothing because it may stain fabrics.
2. Close the lid, slide the drawer closed, and press Start/Pause to restart the cycle.
3. To disable or enable the fabric softener alert, press and hold the Warm Water and Extra Rinse buttons at the same time for three seconds.

If you miss the softener add point:

1. Press the Power button to interrupt the cycle.
2. Select the Rinse+Spin cycle and press the Start button to start the cycle.
3. Add the fabric softener at the chimes following instructions above.

HOW TO USE

CONTROL PANEL FEATURES

WD205C*

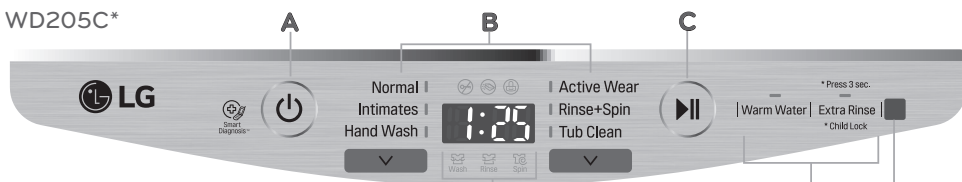

WD100C*/WD200C*

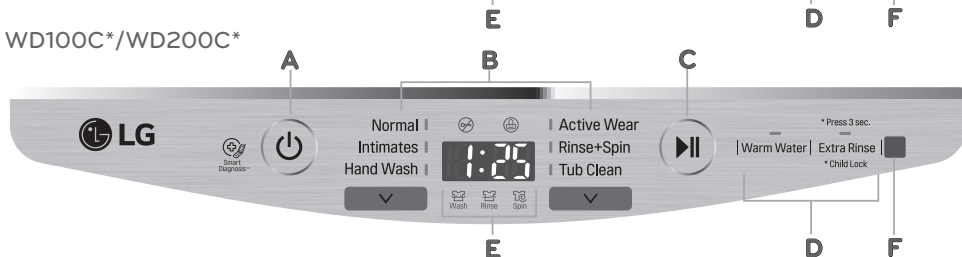

A POWER (ON/OFF) BUTTON

Press to turn the washer ON. Press again to turn the washer OFF. Pressing the POWER button during a cycle will cancel that cycle and any load settings will be lost. The drawer will unlock after a brief pause.

NOTE:

- When the Power button is pressed, the Normal cycle is selected by default. To modify the default options or choose another cycle, press the cycle selector (v) button to illuminate the display.

B CYCLE SELECTOR BUTTON

Press this button to select the desired cycle. Once the desired cycle has been selected, the standard presets will appear in the display. These settings can be adjusted using the cycle setting buttons any time before starting the cycle.

NOTE: To protect your clothing, not all settings are available on all cycle selections.

C START/PAUSE BUTTON

Press this button to start the selected cycle. If the washer is running, use this button to pause the cycle without losing the current settings.

NOTE: If you do not press the START/PAUSE button within 4 minutes of selecting a cycle, the washer automatically turns OFF and all cycle settings are lost.

D OPTION BUTTONS

Use these buttons to adjust the settings for the selected cycle. The setting lights above the buttons illuminate to show the current selection.

E TIME AND STATUS DISPLAY

The display shows the cycle status and estimated time remaining.

F REMOTE CONTROL SENSOR

Use the remote to set the controls without bending down to reach the control panel.

TIME AND STATUS DISPLAY

The time and status display shows the estimated time remaining and cycle progress.

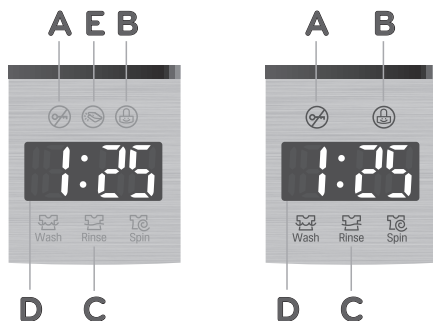

A DRAWER LOCK INDICATOR

The DRAWER LOCK indicator will illuminate once a cycle has started. The indicator light will stay on until the cycle is paused, stopped or has finished.

B CHILD LOCK

When the Child Lock function is activated, the LED lights up. When the Child Lock function is set, except for the POWER button, the other functions are disabled. Once the Child Lock function is disabled, the LED will turn off.

C CYCLE STATUS INDICATOR

These LEDs will illuminate when a cycle is selected to indicate which stages will run. When a cycle is running, the LED for the active stage will blink, and the LEDs for the remaining stages will remain steady. Once a stage is complete, the LED will turn off. If a cycle is paused, the active stage LED will stop blinking.

D ESTIMATED TIME REMAINING

When a cycle is selected, the default time for that cycle is displayed. This time will change as modifiers or options are selected.

NOTE: The time shown is only an estimate. This time is based on normal operating conditions. Several external factors (load size, room temperature, incoming water temperature, water pressure, etc.) can affect the actual time.

E LID OPEN

If the lid is open, the LED blinks. Close the lid, shut the drawer, and press START/PAUSE to start the cycle. Some models do not have the LID OPEN indicator. If the lid is closed and the lid error message is displayed, call for service.

OPERATING THE WASHER



- 1 SORT LAUNDRY AND LOAD THE WASHER**
Sort laundry by fabric type, soil level, color and load size, as needed. Open the lid and load items into the washer.
- 2 CLEANING PRODUCTS**
Measure High-Efficiency (HE) detergent with the dispenser and pour it into the washer.
- 3 TURN ON THE WASHER**
Press the POWER button to turn ON the washer. The cycle lights illuminate and a chime sounds.
- 4 SELECT A CYCLE**
Press the cycle selector button to select the desired cycle. When you press Power the Normal cycle is selected by default. To modify the options, press the cycle selector button to activate the display. The optional remote control can also be used to select the desired cycle.
- 5 ADJUST SETTINGS**
Default settings for the selected cycle can now be changed, if desired, using the option buttons.
NOTE: Not all options are available on all cycles. A different chime will sound and the light will not turn on if the selection is not allowed.
- 6 BEGIN CYCLE**
Press down gently on the lid handle until it clicks and slide the drawer closed. Press START/PAUSE to begin the cycle. The drawer locks, and the washer starts the cycle. If the START/PAUSE button is not pressed within 4 minutes, the washer shuts off and all settings are lost.
- 7 ADD FABRIC SOFTENER**
A repeated chime sounds before the final rinse. When the chime sounds, pause the machine and add liquid fabric softener within three minutes, if desired.
- 8 END OF CYCLE**
When the cycle is finished, a melody will sound. Immediately remove the clothing from the washer to reduce wrinkling.

⚠ WARNING

- To reduce the risk of fire, electric shock, or injury to persons, **read the IMPORTANT SAFETY INSTRUCTIONS** before operating this appliance.

CYCLE GUIDE

The cycle guide below shows the default settings, available options and recommended fabric types for each cycle. Allowable modifier adjustments are shown below the default setting for each cycle.

Key	
	Default
⊙	Available option

Cycle	Cycle Use	Est. Time	Wash Temp.	Extra Rinse	Child Lock
Normal	Lightly soiled cotton, t-shirts, towels, jeans, mixed loads.	39 ~ 116	Warm	⊙	⊙
			Cold		
Intimates	Lingerie, underwear, pajamas, delicates, etc.	47 ~ 103	Warm	⊙	⊙
			Cold		
Hand Wash	Sweaters, knits, items labeled hand-washable, etc.	47 ~ 103	Warm	⊙	⊙
			Cold		
Active Wear	Specially designed/treated performance clothing.	43 ~ 103	Warm	⊙	⊙
			Cold		
Rinse + Spin	Pre-treats stains, or rinses off soap and drains tub	8 ~ 90		⊙	⊙
Tub Clean	Cleans tub and removes mildewy odor.	58	Warm		⊙
			Cold		

WASH CYCLES

Wash cycles are designed for the best wash performance for each type of load. Select the cycle that best matches the load contents for maximum wash performance and fabric care. Press the cycle selector button to select the desired cycle. When you select a wash cycle, the light for the corresponding wash cycle will turn on. See page 19, **OPERATING THE WASHER**, for more details on operating methods.

Normal

Use this cycle to wash lightly soiled normal items, except delicate fabrics such as wool or silk.

NOTE: Pressing the START/PAUSE button without selecting a cycle will cause the NORMAL cycle to begin immediately using the default settings.

Intimates

Use this cycle to wash delicate items such as lingerie or sheer and lacy clothes which could easily be damaged in a normal cycle. This cycle is not for silk items.

Hand Wash

Use this cycle to wash shrinkable woolen or hand-washable items requiring delicate care. Only wash woolen items that are labeled machine wash or hand wash.

Active Wear

Use this cycle to wash performance garments that are specially designed and treated for sports.

Rinse + Spin

Select this option to rinse and spin a load separately from a regular cycle. This can be helpful in preventing fresh stains from setting in fabrics.

Spin Only Cycle

To activate a spin only cycle, select the Rinse+Spin cycle. Then press the Extra Rinse button six times or until the display shows 8 and the Rinse icon is no longer illuminated on the panel.

Tub Clean

Use this cycle to clean the tub of the washing machine.

OPTIONS

After selecting a cycle, select additional features for the load.

NOTE:

- To protect your garments, not every feature is available with every cycle.
- If the START/PAUSE button is not pressed within 4 minutes to start the cycle, the control will shut off and all settings will be lost.

WARM WATER

The warm water option is selected by default on the Normal and Intimates cycles. It can be deselected by pressing the Warm Water button. The water temperature cannot be set on the Rinse + Spin.

EXTRA RINSE

This option add an extra rinse to the selected cycle. Use this option to help ensure the removal of detergent from fabrics. A chime sounds repeatedly before the final rinse so the machine can be paused and liquid fabric softener added, if desired.

NOTE:

- You cannot select the Extra Rinse option with the Tub Clean cycle.
- A chime sounds repeatedly about 20 second before the final rinse so the machine can be paused and liquid fabric softener added, if desired.

CHILD LOCK

Use this option to disable the controls. This feature can prevent children from changing cycles or operating the machine. Once the Child Lock is set, it must be deactivated before any controls, except the Power button, can be used. Once the washer has shut off, the Power button will allow the machine to be turned ON, but the controls will still be locked. When the controls are locked, CL will display alternately with the estimated time remaining. Press and hold the Extra Rinse button for 3 seconds to activate or deactivate Child Lock.

NOTE: Once the controls are locked, they must be manually unlocked to restore operation.

CARE AND CLEANING

⚠ WARNING

To reduce the risk of fire, electric shock, or injury to persons, read and follow this entire Owner's Manual, including the Important Safety Instructions, before operating this washer.

- **Unplug the washer before cleaning to avoid the risk of electric shock.** Failure to follow this warning can cause serious injury, fire, electric shock, or death.
- **Never use harsh chemicals, abrasive cleaners, or solvents to clean the washer.** They will damage the finish.

REGULAR CLEANING

CLEANING THE EXTERIOR

Proper care of your washer can extend its life. The outside of the machine can be cleaned with warm water and a mild, nonabrasive household detergent. Immediately wipe off any spills with a soft, damp cloth.

IMPORTANT: Do not use solvents, cleaning alcohols or similar products. Never use steel wool or abrasive cleaners because they can damage the surface.

CARE AND CLEANING OF THE INTERIOR

Use a towel or soft cloth to wipe around the washer lid opening and lid glass.

Always remove items from the washer as soon as the cycle is complete. Leaving damp items in the washer can cause wrinkling, color transfer, and odor. Run the Tub Clean cycle once a month, or more often if needed, to remove detergent buildup and other residue.

TUB CLEAN CYCLE

Some environmental and usage conditions can cause a residue to build up in the tub over time and can lead to a mildewy or musty smell. The Tub Clean cycle is specially designed to remove this buildup using bleach or other cleaners designed specifically for cleaning washing machines. Run the Tub Clean cycle once a month, or more often under heavy use conditions or if odor is present

1. Remove any clothing from the tub.
2. Dilute 1/4 cup of liquid chlorine bleach in 1 quart of water and pour the mixture in the tub. Do not use any more than 1/4 cup of liquid bleach. Do not let bleach sit in the tub for a long period before running the Tub Clean cycle.

NOTE: For other tub cleaning products, follow the cleaner manufacturer's instructions and recommendations.

3. Close the lid and drawer and press the POWER button to turn the washer ON. Select the Tub Clean cycle then press the START/PAUSE button to begin the cycle. Selecting any other cycle after Tub Clean has been selected will cause the Tub Clean cycle to be cancelled.

4. After the cycle ends, open the lid and allow the tub interior to dry completely.

NOTE:

- Never load laundry while using TUB CLEAN. The laundry may be damaged or contaminated with cleaning products. Make sure to run the Tub Clean cycle **ONLY** when the tub is empty.
- Leave the lid open after finishing the laundry to keep the tub clean.
- Tub Clean should be repeated monthly.

REMOVING MINERAL BUILDUP

If you live in an area with hard water, mineral scale can form on internal components of the washer. Use of a water softener is recommended in areas with hard water.

Use a descaler, such as Washer Magic[®], to remove visible mineral buildup. After descaling, always run the Tub Clean cycle before washing clothing.

Mineral scale and other spots may be removed from the stainless steel tub using a stainless steel cleaner. Do NOT use steel wool or abrasive cleaners.

LEAVE THE LID OPEN

If the washer will not be used for several days, leave the lid and drawer open to allow the tub to dry.

⚠ CAUTION

- Do not allow children or pets to play on or in the washer. Close supervision is necessary when they are near the open washer.

MAINTENANCE

CLEANING THE WATER INLET FILTERS

If the washer does not fill properly, an error message will show on the display. The inlet valve filter screens could be plugged by hard water scale, sediment in the water supply, or other debris.

NOTE: The inlet screens protect the delicate parts of the inlet valve from being damaged by particles that could enter the valves with the water supply. Operating the washer with these filters removed could cause a valve to stick open resulting in flooding and/or property damage.

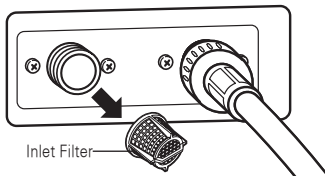
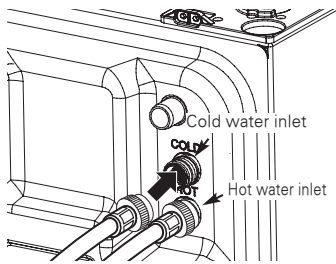

1. Turn OFF both water faucets completely. Unscrew the hot and cold water lines from the back of the washer.

IMPORTANT: Aftermarket hoses are not guaranteed to fit or function correctly. Other hoses may not tighten correctly and could cause leaks. Subsequent damage to product or property will not be covered under the terms of the product warranty.

2. Carefully remove the filters from the water valves and soak them in white vinegar or a lime scale remover, following the manufacturer's instructions. Be careful not to damage the filters while cleaning.
3. Rinse thoroughly before reinstalling. Press the filters back into place.
4. Before reattaching the hoses, flush the hoses and water lines by running several gallons of water into a bucket or drain, preferably with the faucets wide open for maximum flow.

NOTE: An *IE* message may blink on the display when the water pressure is weak or an inlet filter is clogged with dirt. Clean the inlet filter.

⚠️ WARNING

- **Unplug the power cord and turn off the faucets before cleaning.** Failure to do so may cause electric shock.
- **Do not use the washing machine without the inlet filters.** If you use the washing machine without the inlet filters it will cause leaks and product malfunction.
- If you use the washing machine in an area with hard water, the inlet filter may clog due to lime buildup.

STORING THE WASHER

If the washer will not be used for an extended period of time and is in an area that could be exposed to freezing temperatures, perform the following steps to protect the washer from damage.

1. Turn OFF the water supply.
2. Disconnect the hoses from the water supply and drain water from the hoses.
3. Plug the power cord into a properly grounded electrical outlet.
4. Add 1/4 gallon of nontoxic recreational vehicle (RV) antifreeze to the empty tub and close the lid. **Never** use automotive antifreeze.
5. Press the POWER button, then select the Spin Only cycle (see page 20). Press the START/PAUSE button to activate the drain pump. Allow the drain pump to run for one minute, then press the POWER button to shut off the washer. This will expel some of the antifreeze, leaving enough to protect the washer from damage.
6. Unplug the power cord, dry the tub interior with a soft cloth, and close the lid.
7. Store the washer in an upright position.
8. To remove the antifreeze from the washer after storage, run a complete wash cycle using detergent. Do not add laundry to this cycle.

⚠️ WARNING

- **When foreign objects are accumulated, water can flow backward.**

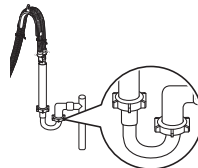

SPECIFICATIONS

Model : WD100C* / WD200C* / WD205C*	
Description	Top-Loading Compact Pedestal Washer
Electrical requirements	120 VAC @ 60 Hz.
Max. water pressure	20~120 PSI (138~827 kPa)
Dimensions	WD100C* 27" (W) x 30 3/4" (D) x 14 1/8"(H), 50 1/2"(D with open) WD200C* / WD205C* 29" (W) x 30 7/8" (D) x 14 1/8"(H), 50 9/16"(D with open)
Net weight	WD100C* 100lb(45.4kg) WD200C* 105lb(47.8kg) WD205C* 108lb(49.1kg)
Max. spin speed	700 RPM

SMART DIAGNOSIS™ SYSTEM

Should you experience any problems with your washing machine, it has the capability of transmitting data via your telephone to the Smart Diagnosis Team. This gives you the capability of speaking directly to our specially trained technicians. The technician records the data transmitted from your machine and uses it to analyze the issue, providing a fast and effective diagnosis.

If you experience problems with your washer, call 1-800-243-0000 (1-888-542-2623 in Canada). Only use the Smart Diagnosis System feature when instructed to do so by the Smart Diagnosis Team. The transmission sounds that you will hear are normal and sound similar to a melody.

Smart Diagnosis cannot be activated unless your washing machine can be turned on by pressing the POWER button. If your washing machine is unable to turn on, then troubleshooting must be done without using Smart Diagnosis.

USING THE SMART DIAGNOSIS™ SYSTEM

Follow the technician's instructions and perform the following steps when requested.

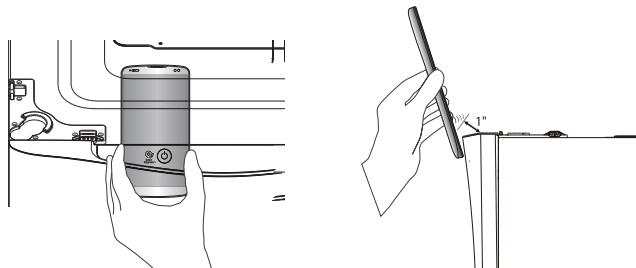

HOLD the mouthpiece of your phone over the power button, when instructed to do so by the call center, no more than one inch from (but not touching) the machine.

NOTE: Do not press any other buttons.

PUSH and hold the Warm Water button while continuing to hold your phone to the POWER button.

LISTEN for three beeps. After you hear the three beeps, release the Warm Water button. Keep the phone in place until the tone transmission has finished. The display will count down the time. Once the countdown is over and the tones have stopped, resume your conversation with the technician, who will then be able to assist you in using the information transmitted for analysis.

Smart Diagnosis is a troubleshooting feature designed to assist, not replace, the traditional method of troubleshooting through service calls. The effectiveness of this feature depends upon various factors, including, but not limited to, the reception of the cellular phone being used for transmission, any external noise that may be present during the transmission, and the acoustics of the room where the machine is located. Accordingly, LG does not guarantee that Smart Diagnosis would accurately troubleshoot any given issue.

TROUBLESHOOTING

FAQS: FREQUENTLY ASKED QUESTIONS

Q: Can the pedestal washer and the front-loading washer be run at the same time?

A: Yes. The pedestal washer is designed to operate simultaneously under LG manufactured front-loading washers produced after 2009. It is not designed for operation under LG toploading washers, LG dryers, non-LG manufactured appliances, or as a standalone unit. For more information regarding compatibility, visit the LG website at www.lg.com/us/twinwash.

Q: How much clothing can be loaded in the pedestal washer?

A: The tub is designed to hold a maximum of 4 lb. (One thick bath towel weighs about one pound when dry.) Do not overload the washer tub. The clothing should fit loosely into the tub and the lid should close easily.

**Q: How much detergent, softener, or bleach should be used per load?
How/when is it added to the machine?**

A: Detergent:

- The pedestal washer requires very little detergent. Most normal loads only require 1 tsp (5 g) of HE detergent. Use a maximum of 2 tsp (10 g) of HE detergent. Do not use a full detergent pod.
- Pour the detergent in the measuring device/dispenser provided with the machine. Place the dispenser in the tub with the clothing before beginning the cycle.
- If the dispenser is missing, place the 1–2 tsp. (5–10 g) detergent directly into the tub.
- For more information, see **Detergent and Dispenser Use**.

Fabric Softener:

- Use $\frac{1}{4}$ the amount recommended by the manufacturer for a normal load. Use the dispenser provided with the machine. For instructions, see **Using Fabric Softener**.

Bleach:

- Do not use liquid or powdered bleach to launder items in the pedestal washer. To safely and effectively launder items using bleach, use the bleach dispenser in the front-loading washer.

Q: Can I slide the drawer out while the cycle is running?

A: No. The drawer locks for safety during operation. Pause the cycle to open the drawer.

Q: What if I want to add an item after I've started the cycle?

A: Press the Start/Pause button to pause the cycle. After the drawer unlocks, add the item and press Start/Pause to restart the cycle. Wash performance may be affected if the item is added after the first few minutes.

**Q: How do I dry out the tub after the cycle is finished?
How do I keep the tub free from mildew and odors?**

A: For best care, wipe the lid and tub dry with a soft cloth or towel after use. Leave the drawer and the lid open to allow maximum air circulation after use. Run the Tub Clean cycle once a month or more frequently as needed. TCL is displayed after every 30 cycles as a reminder.

NORMAL SOUNDS YOU MAY HEAR

The following sounds may be heard while the washer is operating. They are normal.

CLICKING:

Lid lock relay when the lid locks and unlocks.

SPRAYING OR HISSING:

Water spraying or circulating during the cycle.

HUMMING OR GURGLING:

Drain pump is pumping water from the washer at times during a cycle.

WATER SLOSHING SOUND:

A liquid in the balance ring around the wash basket helps the basket spin smoothly.

SOUND OF WATER BEING ADDED AFTER THE WASHER HAS ALREADY BEEN IN OPERATION

- The washer adapts to the load size and type to add more water to the cycle as needed.
- The wash load may be unbalanced. If the washer senses that the load is unbalanced, it will stop and refill to redistribute the load.
- The washer may be diluting laundry additives to add to the wash load.

BEFORE CALLING FOR SERVICE

Your washing machine is equipped with an automatic error-monitoring system to detect and diagnose problems at an early stage. If your washer does not function properly or does not function at all, check the following before you call for service:

Problem	Possible Cause	Solutions
Rattling and clanking noise	Foreign objects, such as keys, coins, or safety pins may be in tub.	Stop washer, check tub for foreign objects. If noise continues after washer is restarted, call for service.
Thumping sound	Heavy wash loads may produce a thumping sound. Wash load may be out of balance.	This is normal. If sound continues, washer is probably out of balance. Stop and redistribute wash load. Pause the cycle and redistribute the load after the lid unlocks.
Vibrating noise	Packaging materials were not removed. Wash load may be unevenly distributed in the tub. Not all leveling feet are resting firmly and evenly on the floor. Floor not rigid enough.	See the Unpacking and Removing Shipping Material section in the installation requirements section. Pause the cycle and redistribute the load after the lid unlocks. See Leveling the Washer in the Installation Instructions section. Make sure that the floor is solid and does not flex. See Flooring in the Installation Requirements section.
Water leaking	Inlet hose connection is loose at faucet, washer, or Y-connector. House drain pipes are clogged. Drain hose has come out of drain connector or is not inserted far enough. Load is too large for the tub.	Check hoses and Y-connectors for leaks, cracks and splits. Check and tighten hose connections. The washer pumps out water very rapidly. Check for water backing up out of the drain pipe during drain. If water is seen coming out of the drain, check for proper drain hose installation and check for restrictions in the drain. Contact a plumber to repair drain pipe. Tie drain hose to inlet hose or standpipe to prevent it from coming out during drain. For smaller drain pipes, insert the drain hose into the pipe as far as the drain hose flange. For larger drain pipes, insert the drain hose into the pipe 1-2 inches past the flange. Reduce the load or use the full-size washing machine. Use the BULKY/BEDDING cycle on the front-loading washer for large or bulky items. Stop the washer and check the load. Make sure the load fits loosely in the tub and the lid closes easily.

BEFORE CALLING FOR SERVICE (continued)

Problem	Possible Cause	Solutions
Wrinkling	Washer not unloaded promptly. Washer overloaded. Hot and cold water inlet hoses are reversed.	Always remove items from the washer as soon as the cycle is complete. The washer can be fully loaded, but the tub should not be tightly packed with items. The lid of the washer should close easily. Hot water rinse can set wrinkles in garments. Check the inlet hose connections.
Excessive sudsing	Too much detergent or incorrect detergent.	HE detergents are formulated specifically for High-Efficiency washers and contain suds-reducing agents. Only use detergent with the High-Efficiency (HE) logo. For detergent quantities refer to the How to Use section. If sudsing or detergent residue continue to be an issue, add an Extra Rinse.
Staining	Bleach or softener was added directly to the wash load in the tub. Washer was not unloaded promptly. Clothes were not properly sorted.	Always remove items from the washer as soon as possible after the cycle is complete. Always wash dark colors separately from light colors and whites to prevent discoloration. Never wash heavily soiled items washed with lightly soiled items.
Washer will not turn ON	Power cord is not properly plugged in. House fuse is blown, circuit breaker has tripped, or power outage has occurred.	Make sure that the plug is plugged securely into a grounded, 3-prong, 120-VAC, 60-Hz outlet. Reset circuit breaker or replace fuse. Do not increase fuse capacity. If the problem is a circuit overload, have it corrected by a qualified electrician.
	NOTE: If the washer stopped during a cycle due to a loss of power, the washer will resume the cycle where it stopped when the power is restored.	
Wash cycle time is longer than usual	The washer automatically adjusts the wash time for the amount of laundry, water pressure and other operating conditions.	This is normal. The washer adjusts cycle time automatically to provide optimal results for the selected cycle. The time remaining shown in the display is only an estimate. Actual time may vary.
Musty or mildewy odor in washer	Incorrect or too much detergent has been used. Inside of tub was not cleaned properly.	Use only High-Efficiency (HE) detergent in accordance with the manufacturer's instructions. This machine requires very little detergent. 1-2 teaspoons is sufficient to wash a full load. Run the Tub clean cycle regularly.
Water leaks	Oversudsing of detergent.	Oversudsing may create leaks, and may be caused by the type and amount of detergent used. High-Efficiency detergent is the only detergent recommended. Always reduce the amount of detergent if the load is small or lightly soiled, or if your water is very soft. Never use more than the maximum amount shown in the dispenser provided.

BEFORE CALLING FOR SERVICE (continued)

Problem	Possible Cause	Solutions
Washer will not operate	<p>Control panel has powered off due to inactivity.</p> <p>Washer is unplugged.</p> <p>Water supply is turned off.</p> <p>Controls are not set properly.</p> <p>Lid or drawer is open</p> <p>Circuit breaker/fuse is tripped/blown.</p> <p>Control needs to be reset.</p> <p>START/PAUSE was not pressed after a cycle was set.</p> <p>Extremely low water pressure.</p> <p>Washer is too cold.</p>	<p>This is normal. Press the POWER button to turn the washer on.</p> <p>Make sure cord is plugged securely into a working outlet.</p> <p>Turn both hot and cold faucets fully on.</p> <p>Make sure the cycle was set correctly, close the lid and press the START/PAUSE button.</p> <p>The washer will not operate if the lid is open. Close the lid and drawer make sure that nothing is caught under the lid preventing it from closing completely.</p> <p>Check house circuit breakers/fuses. Replace fuses or reset breaker. The washer should be on a dedicated branch circuit. The washer will resume the cycle where it stopped once power is restored.</p> <p>Press the POWER button, then re-select the desired cycle and press the START/PAUSE button.</p> <p>Press the POWER button then re-select the desired cycle and press the START/PAUSE button. The washer will shut off if the START/PAUSE button is not pressed within 4 minutes.</p> <p>Check another faucet in the house to make sure that household water pressure is adequate.</p> <p>If the washer has been exposed to temperatures below freezing for an extended period of time, allow it to warm up before pressing the POWER button. Otherwise, the display will not come on.</p>
Washer not filling properly	<p>Filter clogged.</p> <p>Inlet hoses may be kinked.</p> <p>Energy efficiency.</p> <p>Insufficient water supply.</p> <p>lid and drawer are open.</p> <p>Hot and cold inlet hoses are reversed.</p> <p>Water level is too low.</p>	<p>Make sure the inlet filters on the fill valves are not clogged. Refer to the filter cleaning instructions.</p> <p>Check that inlet hoses are not kinked or clogged.</p> <p>This is a High Efficiency (HE) washer. As a result, the water level settings for this washer may be different than for conventional washers.</p> <p>Make sure that both hot and cold water faucets are turned on all the way.</p> <p>The washer will not operate if the lid is open. Close the lid and make sure that nothing is caught under the lid preventing it from closing completely.</p> <p>Check inlet hose connections. Make sure the hot water supply is connected to the hot inlet valve, and the cold water supply is connected to the cold inlet valve.</p> <p>This is a high efficiency washer. The water will not normally cover the clothes. The fill level is optimized for the wash motion to achieve the best wash performance.</p>



BEFORE CALLING FOR SERVICE (continued)

Problem	Possible Cause	Solutions
Washer will not drain water	Kinked drain hose. Drain located higher than 96 in. (243.84 cm). above the floor.	Ensure that the drain hose is not kinked. Make sure that the drain hose is no higher than 8 ft. above the bottom of the washer and is no more than 5 ft. away from the washer.
Poor stain removal	Heavily soiled load. Previously set stains.	The pedestal washer is designed to gently and effectively care for lightly soiled loads. Heavier soils and tougher stains may require the extra cleaning power of the Soak or Stain Care features on the front-loading washer. Articles that have previously been washed may have stains that have been set. These stains may be difficult to remove and may require hand washing or pre-treating to aid in stain removal.
Water leaks every load	Hoses not installed correctly. Hybrid dryer drain hose not installed properly.	Check all fill and drain hose connections to ensure that they are tight and secure. Do not insert hybrid dryer hose into Y-connector further than 3/4 in. See Connecting the Drain Hose. Check clamps and tie straps to ensure they are secure. Install clamps and tie straps if missing. See Connecting the Drain Hose.

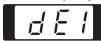
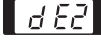
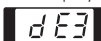
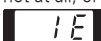
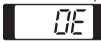
ERROR CODES

Problem	Possible Cause	Solutions
The display shows:  	Drawer is not closed properly	Close the drawer and press START/PAUSE button to start the cycle. If the drawer is closed and the drawer lock error message is displayed, call for service
The display shows: 	Lid is not closed properly	Open the drawer and make sure the latch area is free of clothing or other obstructions. Close the lid, shut the drawer, and press START/PAUSE to start the cycle. If the lid is closed and the lid error message is displayed, call for service
Washer fills with water slowly or not at all, or the display shows: 	Water supply faucets are not fully open. Water line hoses are kinked, pinched, or crushed. Water inlet filters are clogged. Water supply pressure to faucet or house is too low. Water supply connected with leak-limiting hoses.	Make sure that the water faucets are fully open. Make sure that the hoses are not kinked or pinched. Be careful when moving the washer during cleaning and maintenance. Clean the inlet filters. See Maintenance in the Care and Cleaning section. Check another faucet in the house to make sure that household water pressure is adequate and flow is not restricted. Disconnect the inlet hose from the washer and run a few gallons of water through the hose to flush the water supply lines. If flow is too low, contact a plumber to have the water lines repaired. Hoses designed to limit leaks can trip falsely and prevent the washer from filling. The use of leak limiting hoses is not recommended.
Washer will not turn on	Power cord is not properly plugged in. House fuse is blown, circuit breaker has tripped, or power outage has occurred.	Make sure that the plug is plugged seruely into a grounded, 3-prong, 120-VAC, 60-Hz. outlet. Reset circuit breaker or replace fuse. Do not increase fuse capacity. If the problem is a circuit overload, have it corrected by a qualified electrician.
Water in the washer drains slowly or not at all, or the display shows: 	Drain hose is kinked, pinched, or clogged Drain discharge is more than 53 " (134.6 cm) above bottom of washer.	Make sure the drain hose is free of clogs, kinks, etc., and is not pinched behind or under the washer. Adjust or repair drain. Maximum drain height is 53 " (134.6 cm).
Washer chimes repeatedly before final rinse	This is not an error. This is an alert to allow the addition of liquid fabric softener before the final rinse..	See Using Fabric Softener, page 16, for instructions on adding liquid fabric softener to the load. To disable or enable the fabric softener alert, press and hold Warm Water and Extra Rinse at the same time for three seconds.

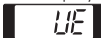
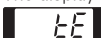
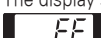
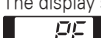
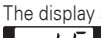
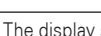
ERROR CODES (continued)

Problem	Possible Cause	Solutions
The display shows: 	If the rebalancing operation (see above) is not successful, this error will be displayed. The load is too small. Heavy articles are mixed with lighter items. The load is out of balance.	The automatic attempt to rebalance the load was not successful. The cycle has been paused to allow the load to be manually adjusted. Small loads may need additional items to be added to allow the washer to balance the loads. The load may have heavy items loaded with lighter items. Always try to wash articles of somewhat similar weight to allow the washer to evenly distribute the weight of the load for spinning. Manually redistribute the load if articles have become tangled preventing the automatic distribution from working properly.
The display shows: 	Control error.	Unplug the power cord and contact your nearest LG service center.
The display shows : 	Water level is too high due to a faulty water valve.	Close the water faucets, unplug the washer, and call for service.
The display shows: 	The water level sensor is not working correctly.	Close the water faucets, unplug the washer, and call for service.
The display shows: 	A motor error has occurred.	Allow the washer to stand for 30 minutes and then restart the cycle. If the LE error code persists, call for service.
The display shows: 	It is time to run the Tub Clean cycle.	Empty the tub, add a diluted solution of 1/4 cup bleach to 1 qt. water to the tub, and select the Tub Clean cycle. To skip the Tub Clean cycle when alerted, press the cycle selector buttons. The message continues to appear for a few more wash cycles and then disappears until the next scheduled tub clean.
The display shows: 	Pedestal washer is being operated without a full-size washer. Stacking switch is not working properly.	The pedestal washer will not operate as a standalone unit. It must be stacked under a full-size LG appliance. The stacking switch will not operate properly if the unit is stacked under a non-LG appliance, or an LG appliance manufactured before 2009.

LG WASHING MACHINE LIMITED WARRANTY (USA)

WARRANTY:

LG Electronics U.S.A., Inc. ("LG") warrants your LG Washing Machine ("product") against defect in materials or workmanship under normal household use, during the warranty period set forth below, LG will, at its option, repair or replace the product. This limited warranty is valid only to the original retail purchaser of the product, is not assignable or transferable to any subsequent purchaser or user, and applies only when the product is purchased through an LG authorized dealer or distributor and used within the United States ("U.S.") including U.S. Territories.

Note: Replacement products and repair parts may be new or factory-remanufactured and are warranted for the remaining portion of the original unit's warranty period or ninety (90) days, whichever is longer. Please retain dated receipt or delivery ticket as evidence of the Date of Purchase for proof of warranty (you may be required to submit a copy to LG or authorized representative).

WARRANTY PERIOD:

Period	One (1) year from date of original retail purchase:	Ten (10) years from date of original retail purchase:	Lifetime from date of original retail purchase:
Scope of Warranty	Any internal /functional Parts & Labor	Drum Motor (Stator, Rotor)	Stainless Steel Drum
Remark	LG will provide parts & labor to repair or replace defective parts.	Parts only. Customer will be responsible for any labor or in-home service to replace defective parts.	

HOW SERVICE IS HANDLED: In-Home Service

In-home service will be provided, as available, during the warranty period subject to servicer availability within the U.S. To receive in-home service, the product must be unobstructed and accessible to service personnel. If the in-home service repair cannot be completed, it may be necessary to remove, repair and return the product. If in-home service is unavailable, LG may elect, at its option, to provide for transportation of the product to and from an LG authorized service center.

THIS LIMITED WARRANTY DOES NOT COVER:

1. Service trips to deliver, pick up, or install the product or for instruction on product use.
2. Replacing house fuses or resetting of circuit breakers, correction of house wiring or plumbing, or correction of product installation.
3. Damage or failure caused by leaky/ broken/ frozen water pipes, restricted drain lines, inadequate or interrupted water supply or inadequate supply of air.
4. Damage or failure caused by accidents, pests and vermin, lightning, wind, fire, floods or acts of God.
5. Damage or failure resulting from misuse, abuse, improper installation, repair or maintenance. Improper repair includes use of parts not approved or specified by LG.
6. Damage or failure caused by unauthorized modification or alteration to the product.
7. Damage or failure caused by incorrect electrical current, voltage, or plumbing codes.
8. Cosmetic damage, including scratches, dents, chips or other damage to the finish of the product, unless such damage results from defects in materials or workmanship and is reported to LG within seven (7) calendar days from the date of delivery.
9. Damage or missing items to any display, open box, discounted, or refurbished product.
10. Product where the original factory serial numbers have been removed, defaced or changed in any way.
11. Repairs when product is used in other than normal and usual household use (e.g. rental, commercial use, offices, or recreational facilities) or contrary to the instructions outlined in the owner's manual.
12. The removal and reinstallation of the Product if it is installed in an inaccessible location.

THIS WARRANTY IS IN LIEU OF ANY OTHER WARRANTY, EXPRESS OR IMPLIED, INCLUDING AND WITHOUT LIMITATION TO, ANY WARRANTY OF MERCHANTABILITY OR FITNESS FOR A PARTICULAR PURPOSE. TO THE EXTENT ANY IMPLIED WARRANTY IS REQUIRED BY LAW, THIS WARRANTY IS LIMITED IN DURATION TO THE TERM PERIOD EXPRESSED ABOVE. REPAIR OR REPLACEMENT AS PROVIDED UNDER THIS WARRANTY IS THE EXCLUSIVE REMEDY FOR THE CUSTOMER. NEITHER THE MANUFACTURER NOR ITS U.S. DISTRIBUTOR SHALL BE LIABLE FOR ANY INCIDENTAL, CONSEQUENTIAL, INDIRECT, SPECIAL, OR PUNITIVE DAMAGES OF ANY NATURE, INCLUDING AND WITHOUT LIMITATION TO, LOST REVENUES OR PROFITS, OR ANY OTHER DAMAGE, WHETHER BASED IN CONTRACT, TORT, OR OTHERWISE.

SOME STATES DO NOT ALLOW THE EXCLUSION OR LIMITATION OF INCIDENTAL OR CONSEQUENTIAL DAMAGES OR LIMITATIONS ON HOW LONG AN IMPLIED WARRANTY LASTS. SO THE ABOVE EXCLUSION OR LIMITATION MAY NOT APPLY TO YOU. THIS WARRANTY GIVES YOU SPECIFIC LEGAL RIGHTS AND YOU MAY ALSO HAVE OTHER RIGHTS THAT VARY FROM STATE TO STATE.

HOW TO OBTAIN WARRANTY SERVICE & ADDITIONAL INFORMATION:
below:

Write your warranty information

Call 1-800-243-0000 or visit our website at www.lg.com.
Mail to: LG Customer Information Center (ATTN: CIC)
201 James Record Road, Huntsville, AL 35824

Product Registration Information:
Model:
Serial Number:
Date of Purchase:



ESPAÑOL

MANUAL DEL PROPIETARIO LAVADORA

Lea este manual del propietario detenidamente antes de utilizar el aparato y guárdelo para futuras consultas.

WD100C*

WD200C*

WD205C*

www.lg.com

ÍNDICE

3 INSTRUCCIONES IMPORTANTES DE SEGURIDAD

- 3 Precauciones básicas de seguridad
- 4 Requisitos de conexión a tierra
- 5 Instrucciones de seguridad para la instalación
- 6 Instrucciones de seguridad para uso, cuidado y limpieza y eliminación

7 CARACTERÍSTICAS Y VENTAJAS

- 7 Piezas clave y componentes
- 7 Accesorio incluido
- 7 Accesorio necesario

8 INSTRUCCIONES DE INSTALACIÓN

- 8 Elección de la ubicación adecuada
- 8 Toma de corriente
- 8 Suelo
- 9 Desembalaje y eliminación del material de transporte
- 10 Panorama General de Conexiones
- 11 Conexión del suministro de agua
- 12 Conexión de la manguera de desagüe
- 13 Nivelación de la lavadora
- 14 Conexión a la red eléctrica
- 15 Clasificación de las carga de lavado
- 16 Uso De Detergente Y Blanqueador

17 MODO DE UTILIZACIÓN

- 17 Características del panel de control
- 18 Pantalla de tiempo y estado
- 19 Funcionamiento de la lavadora
- 20 Guía de ciclos
- 21 Options (Opciones)
 - 21 Warm Water (Agua Templada)
 - 21 Extra Rinse (Aclarado Extra)
 - 21 Child Lock (Bloqueo Para Niños)

22 CUIDADO Y LIMPIEZA

- 22 Limpieza regular
 - 22 Limpieza del exterior
 - 22 Cuidado y limpieza del interior
 - 22 Ciclo de limpieza de tambor
 - 22 Eliminación de depósitos minerales
 - 22 Deje la puerta abierta
- 23 Mantenimiento

24 ESPECIFICACIONES

24 SISTEMA SMART DIAGNOSIS™

25 SOLUCIÓN DE PROBLEMAS

- 25 Faq: Preguntas Frecuentes
- 26 Sonidos normales que podrá escuchar
- 26 Antes de llamar al servicio técnico
- 30 Códigos de error

32 GARANTÍA

INSTRUCCIONES IMPORTANTES DE SEGURIDAD

MENSAJES DE SEGURIDAD

Por su seguridad, cumpla con la información de este manual para reducir el riesgo de incendio, explosión o descargas eléctricas o para evitar daños materiales y lesiones graves o mortales. Su seguridad y la de otras personas son muy importantes. Hay muchos mensajes importantes de seguridad en este manual y/o el aparato. Lea siempre los mensajes de seguridad y cumpla con sus instrucciones. Este es el símbolo de alerta de seguridad.



Este símbolo le alerta de peligros potenciales que pueden causar daños materiales y/o lesiones graves o mortales.

Todos los mensajes de seguridad estarán precedidos de un símbolo de alerta y la palabra PELIGRO, ADVERTENCIA o PRECAUCIÓN. Estas palabras significan:

- ⚠ PELIGRO** Podría sufrir lesiones graves o mortales si no cumple con estas instrucciones inmediatamente.
- ⚠ ADVERTENCIA** Podría sufrir lesiones graves o mortales si no cumple con estas instrucciones.
- ⚠ PRECAUCIÓN** Podría sufrir lesiones leves o causar daños al producto si no sigue las instrucciones.

Todos los mensajes de seguridad le indicarán los peligros potenciales, cómo reducir la posibilidad de sufrir lesiones y qué ocurrirá si no se siguen las instrucciones.

PRECAUCIONES BÁSICAS DE SEGURIDAD

⚠ ADVERTENCIA

Para reducir el riesgo de incendio, descargas eléctricas o lesiones durante el uso de este producto, cumpla con todas las instrucciones básicas de seguridad, incluidas las siguientes:

- Utilice este aparato solo para los fines descritos en el manual del propietario.
- **Antes del uso, la lavadora debe instalarse correctamente, según se describe en este manual.**
- **No lave ropa que se haya limpiado, lavado, empapado o manchado previamente con disolventes de limpieza u otras sustancias inflamables o explosivas**, ya que los vapores que emiten podrían causar un incendio o una explosión.
- **No añada gasolina, disolventes de limpieza en seco u otras sustancias inflamables o explosivas al agua de lavado.** Estas sustancias emiten vapores que podrían causar un incendio o una explosión.
- En determinadas circunstancias, puede producirse gas hidrógeno en un sistema de agua caliente que no se haya usado durante 2 semanas o más tiempo. **EL GAS HIDRÓGENO ES EXPLOSIVO. Si no se ha usado el sistema de agua caliente durante ese tiempo, antes de usar la lavadora abra todos los grifos de agua caliente y deje que fluya el agua durante varios minutos.** Esto liberará el gas hidrógeno que haya podido acumularse. Debido a que el gas es inflamable, **no fume ni utilice llamas abiertas durante este tiempo.**
- Los niños podrían quedar atrapados en el interior de la lavadora y asfixiarse.
- **Antes de retirar la lavadora del servicio o desecharla, quite la puerta para evitar que los niños se suban sobre ella o jueguen en el interior.**
- **No instale ni guarde la lavadora en un lugar expuesto a la intemperie o con temperaturas bajo cero.**
- **No manipule los controles.**
- Mantenga el área debajo y alrededor del aparato libre de materiales combustibles (pelusa, papel, trapos, etc.), gasolina, productos químicos y otros vapores y líquidos inflamables.
- El servicio de mantenimiento debe ser realizado por un técnico calificado. **No desmonte la lavadora.**
- **Consulte en las instrucciones de instalación los requisitos para la conexión a tierra.**
- **ADVERTENCIA:** Este equipo contiene productos químicos que, según el Estado de California, causan cáncer y malformaciones congénitas u otros daños reproductivos. **Lávese las manos tras su utilización.**

- **SIGA siempre las instrucciones de cuidados de la ropa incluidos en la etiqueta del fabricante.**
- **No coloque artículos expuestos a aceite de cocina en la lavadora.** Los artículos contaminados con aceite de cocina podrían causar una reacción química que haría que la carga de lavado se incendie.
- **Utilice suavizantes u otros productos para la eliminación de la electricidad estática del modo recomendado por el fabricante.**
- Esta lavadora no ha sido diseñada para uso marítimo o para instalaciones móviles, como vehículos de recreo, aviones, etc.
- **Cierre los grifos del agua y desenchufe la lavadora si no va a utilizarse durante un periodo de tiempo prolongado, por ejemplo, durante las vacaciones.**
- **No la utilice para artículos que contengan espuma de caucho o materiales de textura similar.**
- El material de embalaje puede resultar peligroso para los niños. Existe peligro de asfixia. Mantenga el material de embalaje alejado de los niños.
- **Antes de cargar la ropa, revise siempre el interior de lavadora por si hubiera algún objeto extraño en su interior. Mantenga la puerta cerrada cuando no esté usando la lavadora.**
- **No introduzca la mano en el interior si el tambor o el agitador están en movimiento.**
- **Si se produce una fuga de gas (gas propano, gas LP, etc.), ventile el área inmediatamente. No encienda o apague ningún aparato ni las luces. No utilice un ventilador.** Podría saltar una chispa y causar una explosión o un incendio.
- **En caso de una fuga de gas (como gas propano, gas licuado de petróleo, etc.), ventile el área inmediatamente. No encienda ni apague aparatos ni luces. No use un ventilador.** Una chispa podría producir una explosión o un incendio.
- **No repare ni reemplace ninguna parte de este aparato ni intente darle servicio, a menos que esté específicamente recomendado en las instrucciones de mantenimiento o en las instrucciones publicadas de reparaciones que estas tareas pueden ser realizadas por el usuario. Usted debe comprender y contar con la capacidad para cumplir las instrucciones.**

LEA TODAS LAS INSTRUCCIONES ANTES DEL USO.

ADVERTENCIA

Por su seguridad, cumpla con la información de este manual para reducir el riesgo de incendio o explosión o para evitar daños materiales y lesiones personales graves o mortales.

REQUISITOS DE CONEXIÓN A TIERRA

Si se produce un fallo o una avería, la toma de tierra reduce el riesgo de descargas eléctricas proporcionando un hilo de escape para la corriente eléctrica. Este aparato está equipado con un cable puesto a tierra y un enchufe de tierra. El enchufe debe conectarse en una toma eléctrica adecuada, correctamente instalada y con conexión a tierra, **ALGUNAS PARTES INTERNAS SE HAN DEJADO SIN CONEXIÓN A TIERRA DE FORMA INTENCIONAL Y PUEDEN REPRESENTAR UN RIESGO DE DESCARGA ELECTRÓNICA SOLO DURANTE EL SERVICIO. PERSONAL DE SERVICIO: NO TOQUE LAS SIGUIENTES PARTES MIENTRAS EL APARATO ESTÉ ENERGIZADO: BOMBA, VÁLVULA, MOTOR, CONTROL** de acuerdo con los códigos y reglamentos locales.

ADVERTENCIA

La conexión incorrecta del conductor de tierra puede causar riesgo de descargas eléctricas. Consulte a un electricista o técnico calificado si tiene dudas acerca de la correcta conexión a tierra del aparato. No modifique el enchufe incluido con el aparato. Si la toma no es compatible, solicite la instalación de una toma adecuada a un electricista calificado. El incumplimiento de las siguientes advertencias puede causar lesiones graves o mortales, un incendio o descargas eléctricas.

ADVERTENCIA

Por su seguridad, cumpla con la información de este manual para reducir el riesgo de incendio, explosión o descargas eléctricas, o para evitar daños materiales y lesiones graves o mortales.

INSTRUCCIONES DE SEGURIDAD PARA LA INSTALACIÓN

ADVERTENCIA

Para reducir el riesgo de incendio, descargas eléctricas o lesiones durante el uso de este producto, cumpla con todas las instrucciones básicas de seguridad, incluidas las siguientes:

- **Consulte las INSTRUCCIONES DE INSTALACIÓN para conocer los procedimientos detallados de conexión a tierra.** Las instrucciones de instalación se incluyen con la lavadora como referencia para el instalador. Si se cambia de ubicación la lavadora, deberá ser comprobada y reinstalada por un técnico calificado. El incumplimiento de esta advertencia puede causar lesiones graves o mortales, un incendio o descargas eléctricas.
- **Bajo ninguna circunstancia corte o retire la tercera clavija (tierra) del cable de alimentación eléctrica.** El incumplimiento de esta advertencia puede causar lesiones graves o mortales, un incendio o descargas eléctricas.
- **Por su seguridad, este aparato debe estar correctamente conectado a tierra.** El incumplimiento de esta advertencia puede causar lesiones graves o mortales, un incendio o descargas eléctricas.
- **El cable de alimentación de este aparato está equipado con un enchufe de tres clavijas (tierra) adecuado para una toma estándar de pared de tres clavijas (tierra)** para reducir la posibilidad de descargas eléctricas.
- **Esta lavadora debe conectarse a una toma de 120 VCA, 60 Hz con toma de tierra.** El incumplimiento de esta advertencia puede causar lesiones graves o mortales, un incendio o descargas eléctricas.
- **Solicite a un electricista calificado que compruebe la correcta conexión a tierra.** El incumplimiento de esta advertencia puede causar lesiones graves o mortales, un incendio o descargas eléctricas.
- **Cuando tenga una toma de pared estándar de dos clavijas, es su responsabilidad y obligación sustituirla por una toma de tres clavijas.** El incumplimiento de esta advertencia puede causar lesiones graves o mortales, un incendio o descargas eléctricas.
- **No instale el producto sobre una moqueta. Instale la lavadora sobre un suelo estable.** El incumplimiento de esta advertencia puede causar daños graves por fugas.
- **La lavadora debe conectarse siempre a una toma eléctrica individual con un voltaje nominal que se corresponda con la placa de clasificación eléctrica.** Esto proporciona un óptimo desempeño y, además, evita sobrecargar los circuitos eléctricos de la casa, lo que podría causar un peligro de incendio por sobrecalentamiento de los cables.
- **Si se instala el pedestal lavador con una lavadora de carga frontal LG y una secadora a gas LG y no se dispone de suficientes tomas eléctricas, puede utilizarse un cable de extensión cuya capacidad no sea menor que la del circuito derivado.**
- **No desenchufe la lavadora tirando del cable.** Hágalo siempre tirando con fuerza del enchufe y sacándolo de la toma de pared. El incumplimiento de esta advertencia puede causar lesiones graves o mortales, un incendio o descargas eléctricas.
- **Repare o cambie inmediatamente los cables de alimentación pelados o que hayan sufrido cualquier otro daño. No utilice un cable agrietado o con señales de abrasión en toda su longitud o sus extremos.** El incumplimiento de esta advertencia puede causar lesiones graves o mortales, un incendio o descargas eléctricas.
- **Cuando instale o mueva la lavadora, tenga cuidado de no aplastar o dañar el cable eléctrico.** El incumplimiento de esta advertencia puede causar lesiones graves o mortales, un incendio o descargas eléctricas.
- **Con el fin de evitar el riesgo de descargas eléctricas y garantizar la estabilidad durante su funcionamiento,** la lavadora debe ser instalada y conectada eléctricamente de acuerdo con los códigos locales, por una persona cualificada.
- **La lavadora es pesada. Pueden ser necesarias dos o más personas para instalar y mover el aparato.** De lo contrario podría sufrir lesiones en la espalda o de otro tipo.
- **Instálela o guárdela donde no quede expuesta a temperaturas bajo cero o a la intemperie.** El incumplimiento de esta advertencia puede causar daños graves por fugas.
- **Para reducir el riesgo de descargas eléctricas, no instale la lavadora en espacios con humedad.** El incumplimiento de estas advertencias puede causar lesiones graves o mortales, un incendio o descargas eléctricas.
- **Para reducir el riesgo de daños personales, siga todos los procedimientos de seguridad recomendados por la industria incluyendo guantes de goma y gafas de seguridad.** Si no sigue todas las advertencias de seguridad de este manual puede dañar el producto, causar daños materiales o sufrir lesiones graves o mortales.
- **No intente nunca hacer funcionar este electrodoméstico si está estropeado, funciona mal, parcialmente desmontado o tiene piezas perdidas o rotas, incluidos el cable o enchufe dañado.**
- **Para minimizar la posibilidad de sufrir una descarga eléctrica, antes de cualquier operación de mantenimiento o limpieza desenchufe el electrodoméstico de la toma de corriente o desconecte la lavadora del cuadro eléctrico retirando el fusible o apagando el interruptor.**
- **El enchufe debe conectarse a una toma correctamente instalada y conectada a tierra.** Si conecta el cable en la dirección opuesta en el enchufe, los hilos pueden resultar dañados, lo que podría provocar una descarga eléctrica o un incendio.

- El pedestal lavador está previsto exclusivamente para su instalación y uso debajo de una lavadora de carga frontal fabricada por LG. El pedestal lavador no está diseñado para operar como una unidad independiente, debajo de una lavadora LG de carga superior, de una secadora ni de lavadoras de otras marcas.
- No use el pedestal lavador presionando el interruptor de apilado sin la lavadora de tamaño completo. Podrían producirse lesiones graves o mal funcionamiento.
- No use el pedestal lavador para apilar dos o más lavadoras. Podrían producirse lesiones graves o mal funcionamiento.

⚠ ADVERTENCIA

Por su seguridad, cumpla con la información de este manual para reducir el riesgo de incendio, explosión o descargas eléctricas, o para evitar daños materiales y lesiones graves o mortales.

INSTRUCCIONES DE SEGURIDAD PARA USO, CUIDADO, LIMPIEZA Y ELIMINACIÓN

⚠ ADVERTENCIA

Para reducir el riesgo de incendio, descargas eléctricas o lesiones durante el uso de este producto, cumpla con todas las instrucciones básicas de seguridad, incluidas las siguientes:

- Antes de su limpieza, desconecte la lavadora para evitar el riesgo de descarga eléctrica.
- No utilice productos químicos abrasivos, limpiadores abrasivos o disolvente para limpiar la lavadora. Podrían dañar el acabado.
- No coloque trapos grasientos y aceitosos encima de la lavadora. Estas sustancias emiten vapores que podrían provocar un incendio.
- No lave prendas manchadas con aceite vegetal o de cocina. Estas prendas pueden contener restos de aceite tras el lavado. Debido a este aceite, el tejido puede desprender humo o prenderse fuego.
- Antes de proceder a realizar cualquier tipo de mantenimiento, desconecte el aparato. Colocar los controles en la posición APAGADA no desconecta el electrodoméstico. El incumplimiento de esta advertencia puede causar lesiones graves o mortales, un incendio o descargas eléctricas.
- No mezcle diferentes productos de lavado en una misma carga a menos que se especifique en la etiqueta.
- No mezcle lejía con amoníaco o ácidos como el vinagre. Siga las instrucciones del envase cuando use productos de lavandería. Un uso incorrecto puede provocar gases tóxicos, conllevando lesiones graves o la muerte.
- Nunca intente meter nada dentro de la lavadora mientras ésta se encuentra en movimiento. Antes de cargar, descargar o añadir prendas pulse el botón START / PAUSE para detener el tambor por completo. El incumplimiento de esta advertencia puede causar lesiones graves o mortales, un incendio o descargas eléctricas.
- No permita que los niños jueguen sobre la lavadora o en su interior. No deje a los niños desatendidos cuando estén cerca de la lavadora en funcionamiento. A medida que los niños crecen, enséñeles el uso correcto y seguro de los electrodomésticos. Si ignora las advertencias de seguridad, podrían causarse daños personales o la muerte.
- Elimine la bolsa de plástico y otros materiales de embalaje una vez desembalada la lavadora. Es posible que los niños deseen usarlas para jugar. Los cartones cubiertos con alfombras, colchas o láminas de plástico se pueden convertir en cámaras herméticas. Si ignora las advertencias de seguridad, podrían causarse daños personales o la muerte.
- Mantenga el jabón en polvo y los detergentes fuera del alcance de los niños. Para evitar lesiones personales, siga las advertencias de las etiquetas de los productos. Si ignora las advertencias de seguridad, podrían causarse daños personales o la muerte.
- Antes de retirar la lavadora para su reparación o eliminación, quite la puerta del compartimento de lavado para evitar que los niños o animales pequeños puedan quedar atrapados en el interior. De lo contrario, podría sufrir lesiones graves o mortales.
- Mantenga las manos y los objetos extraños alejados de la puerta al cerrarla. De lo contrario podría sufrir lesiones.
- No toque el enchufe con las manos mojadas. Puede causar descargas eléctricas.
- No toque el agua de desagüe de la máquina durante un ciclo de lavado o secado de alta temperatura. El agua está caliente y podría causarle quemaduras o lesiones.
- No coloque objetos (velas y cigarrillos encendidos, platos, productos químicos, objetos metálicos, etc.) en la parte superior del aparato. Podría causar descargas eléctricas, un incendio, problemas con el producto o lesiones.
- No instale ni guarde la lavadora expuesta a temperaturas bajo cero. El agua podría congelarse en las mangueras y dañar la máquina. Prepare la lavadora antes de guardarla o moverla a un lugar con temperaturas bajo cero. Consulte el manual de instrucciones.
- No empuje la tapa con demasiada fuerza. Podría romperse el cristal de la tapa.
- No se suba al pedestal lavador. Podría causar lesiones graves o daños a la lavadora.
- No abra ni cierre la tapa con el pie. Hacerlo puede causar lesiones personales o daños al producto.

GUARDE ESTAS INSTRUCCIONES

CARACTERÍSTICAS Y VENTAJAS PIEZAS CLAVE Y COMPONENTES

El aspecto y las especificaciones pueden variar sin aviso para mejorar la calidad del producto.

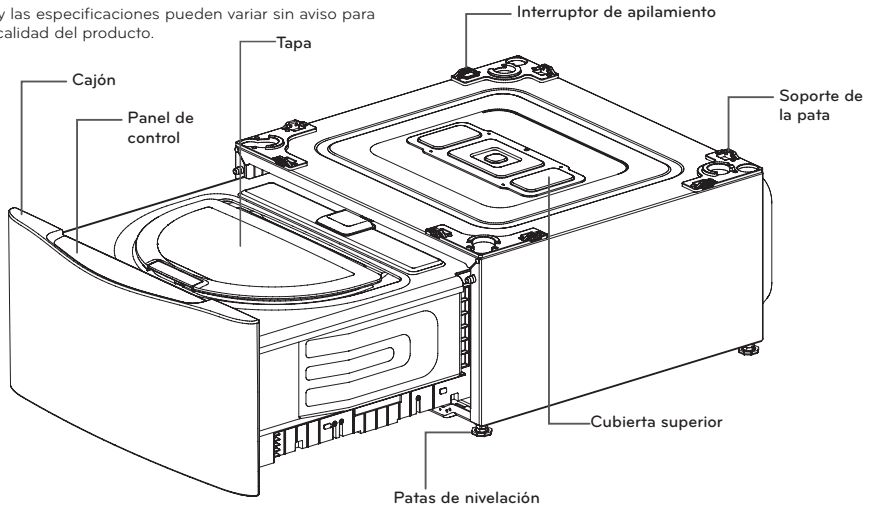

ESPAÑOL

A MOTOR INVERTER DIRECT DRIVE

El motor inverter, conectado directamente al tambor produce pocas vibraciones y ofrece una excelente durabilidad y una prologada vida útil.

B CUBA DE ACERO INOXIDABLE NEVERUST™ COMPACTA

El diseño eficiente le brinda gran capacidad en un espacio reducido.

C PANEL TÁCTIL DELANTERO

La pantalla LED sencilla muestra las opciones de ciclos, la configuración, el estado del ciclo y el tiempo restante estimado. Los botones táctiles ofrecen mayor comodidad y un diseño estético de alta calidad.

E DIAGNÓSTICO INTELINGENTE™

Si alguna vez sufre un problema con su lavadora LG, no tiene por qué preocuparse. El servicio Diagnóstico inteligente™ le ayuda a diagnosticar el problema por teléfono o mediante una sencilla aplicación en su teléfono móvil, lo que permite minimizar las costosas e inconvenientes llamadas de servicio.

D CONTROL REMOTO RCW1 (OPCIONAL)

¿No desea inclinarse para alcanzar los controles? Configure los ciclos con solo apretar un botón del control remoto. (Accesorio incluido [modelo WD205C], o disponible para la compra en línea o a través de un vendedor minorista de LG.)

ACCESORIOS INCLUIDOS					ACCESORIOS NECESARIOS
2 Mangueras de entrada cortas	2 Conectores en Y para mangueras de entrada	Conector en Y para la manguera de desagüe	Manguera de desagüe	Apoyos antideslizantes	
					2 Mangueras de entrada
Llave	2 Precintos	2 Abrazaderas de 1 alambre y de banda	Tornillos	Detergente líquido	

NOTA: Póngase en contacto con el Servicio de atención al cliente de LG llamando al 1-800-243-0000 (1-888-542-2623 en Canadá) si faltan accesorios o si desea comprarlos. Para obtener una lista de las lavadoras LG de carga frontal compatibles con el pedestal lavador, visite el sitio web de LG www.lg.com/us/twinwash.

INSTRUCCIONES DE INSTALACIÓN

ELECCIÓN DE LA UBICACIÓN ADECUADA SUELO

⚠️ ADVERTENCIA

- Para obtener una lista de las lavadoras LG de carga frontal compatibles con el pedestal lavador, visite el sitio web de LG www.lg.com/us/twinwash.
- Almacene e instale la lavadora donde no esté expuesta a la intemperie o a temperaturas bajo cero. El incumplimiento de esta advertencia puede causar lesiones graves, incendios, descargas eléctricas o la muerte.
- Conecte la lavadora a tierra correctamente cumpliendo con los códigos y ordenanzas locales. El incumplimiento de esta advertencia puede causar lesiones graves o mortales, un incendio o descargas eléctricas.
- Para reducir el riesgo de descargas eléctricas, no instale la lavadora en espacios con humedad. El incumplimiento de esta advertencia puede causar lesiones graves o mortales, un incendio o descargas eléctricas.
- Compruebe que la circulación del aire no se vea interrumpida por alfombras, esterillas u otros objetos.
- No retire la clavija de tierra. No utilice un adaptador de 2 clavijas ni un cable de extensión de 2 conductores. El incumplimiento de estas advertencias puede causar lesiones graves, incendios, descargas eléctricas o la muerte.

⚠️ PRECAUCIÓN

- Este pedestal debe instalarse debajo de una lavadora LG de carga frontal compatible, fabricada después de 2008. (La máquina de 29" de ancho debe colocarse debajo de una lavadora LG de carga frontal de 29" de ancho. La máquina de 27" de ancho debe colocarse debajo de una lavadora LG de carga frontal de 27" de ancho.)
- El pedestal no funciona como una unidad autónoma.
- El pedestal lavador debe colocarse debajo de un aparato LG para que funcione adecuadamente.

TOMA DE CORRIENTE

- La toma de corriente debe estar dentro de un área mínima de 60 pulgadas. (1,5 m) a cualquiera de los lados de la lavadora.
- El aparato y la toma eléctrica deberán colocarse de modo que pueda acceder fácilmente al enchufe.

⚠️ ADVERTENCIA

- Para un mejor rendimiento, conecte la lavadora en una toma de corriente individual exclusiva. Si fuera necesario, utilice un adaptador de 3 clavijas o un cable de extensión de 3 conductores con un enchufe de 3 clavijas (conexión a tierra) nuevos y homologados por UL y con una clasificación que no sea menor que la del circuito derivado. No utilice un cable de extensión de una longitud mayor a tres pies. El incumplimiento de estas advertencias puede resultar en lesiones graves, incendios, descargas eléctricas o la muerte.
- La toma de corriente debe estar puesta a tierra cumpliendo los códigos y las regulaciones locales.
- Se recomienda un fusible de demora de tiempo o disyuntor.

NOTA: Es responsabilidad y obligación personal del dueño del producto pedir a un electricista calificado que instale la toma de corriente adecuada.

- Para reducir los ruidos y vibraciones, la unidad DEBE nivelarse e instalarse sobre un suelo sólido y resistente.
- La inclinación debajo de la lavadora no debe ser superior a 1 pulgada de lado a lado o de delante a atrás.
- No se recomienda la instalación sobre moquetas o superficies de azulejos blandos.
- Nunca instale la lavadora en una plataforma o en una estructura poco resistente.

NOTA: La lavadora debe estar instalada en suelo estable para minimizar la vibración durante el centrifugado. Los suelos de hormigón son los mejores, pero los de madera son suficientes siempre que cumplan las normas FHA. No instale la lavadora sobre alfombras o a la intemperie.

No utilice una bandeja colectora, ya que puede bloquear el cajón. El uso de la bandeja colectora puede provocar un aumento de la vibración y el ruido durante el funcionamiento.

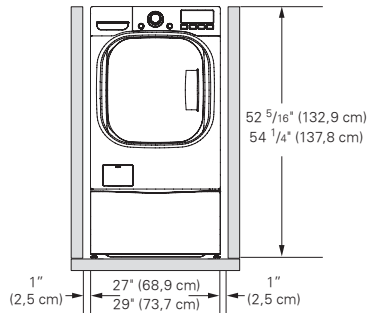

Deje espacio suficiente para las tuberías de agua y el flujo del aire. Mínimo 1 pulgada (2,5 cm) a los lados y 4 pulgadas (10 cm) en la parte trasera. Asegúrese de tener en cuenta molduras de paredes, puertas o suelo por si desea aumentar el espacio requerido.

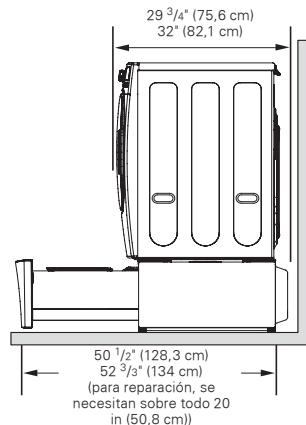

DESEMBALAJE Y ELIMINACIÓN DEL MATERIAL DE TRANSPORTE

- Una vez retirados el cartón y material de transporte, levante la lavadora de la base de espuma. Asegúrese de quitar el soporte de espuma del tambor colocado en la base y que no quede pegado en la base inferior de la lavadora.

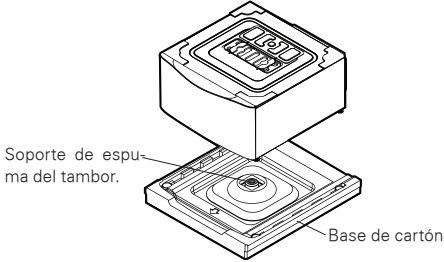

Si debe inclinar la lavadora para quitar los materiales de embalaje de la base, hágalo siempre cuidadosamente sobre su parte lateral. NO incline la lavadora sobre la parte frontal o posterior.

- Guarde los pernos (que contiene el Manual del Propietario, piezas y muestras de productos de lavado) para futuros usos. Si la lavadora debe moverse en el futuro, el bloque de espuma ayudará a prevenir daños durante su transporte. **NOTA:** Para prevenir daños, no retire la espuma del bloque hasta que la lavadora esté en su ubicación final. Cubra el agujero superior con la tapa superior e instale 4 tornillos para sujetarla.

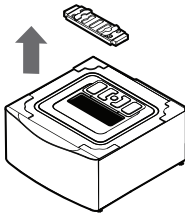

- Gire la tapa superior aproximadamente 180 grados. Cubra el agujero superior con la tapa superior e instale los 4 tornillos para sujetarla.

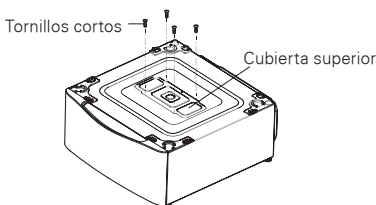

- Asegúrese de que las patas de nivelación de la lavadora de carga frontal estén completamente retraídas antes de colocarla encima del pedestal lavador. Coloque el aparato sobre la parte superior del pedestal lavador.

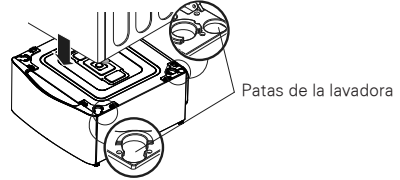

- Asegúrese de que los agujeros del pedestal lavador se alineen con los agujeros de la lavadora de carga frontal. Luego, instale los 4 tornillos largos (incluidos en el empaque) en las esquinas para acoplar firmemente la lavadora de carga frontal al pedestal lavador.

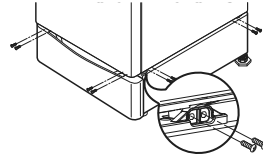

- Extienda las patas de la lavadora de carga frontal suavemente hasta que esta se encuentre bien colocada sobre el pedestal lavador.

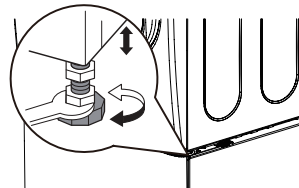

HERRAMIENTAS NECESARIAS

- Alicates
- Nivel de carpintería

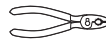

- Destornillador

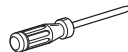

⚠ ADVERTENCIA

- Debe instalarse la cubierta superior para evitar el riesgo de descargas eléctricas o cortocircuitos. Si no lo hace, se pueden producir lesiones graves, incendios, descargas eléctricas o la muerte.

PANORAMA GENERAL DE CONEXIONES

CONEXIÓN DE LAS TUBERÍAS DE SUMINISTRO DE AGUA AL APARATO PRINCIPAL

1. Lavadora de carga frontal y pedestal lavador con secadora.

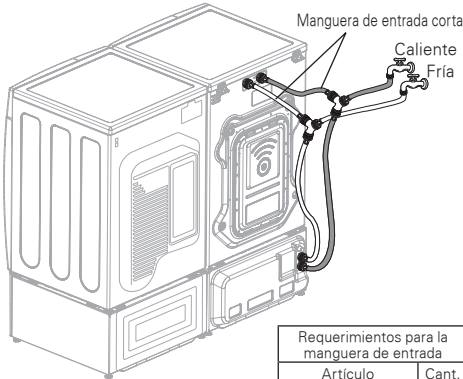

Requerimientos para la manguera de entrada	
Artículo	Cant.
Conector en Y	2
Manguera de entrada corta	2
Manguera de entrada larga	4

La manguera de entrada larga se vende por separado

2. Lavadora de carga frontal y pedestal lavador con secadora a vapor turbo.

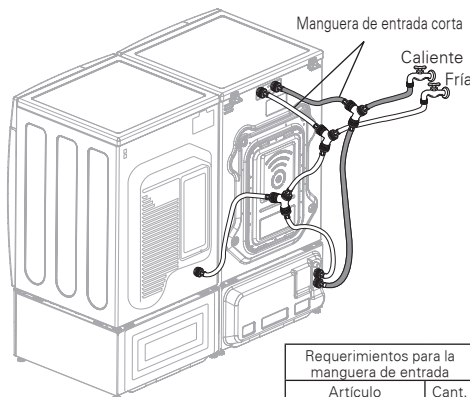

Requerimientos para la manguera de entrada	
Artículo	Cant.
Conector en Y	3
Manguera de entrada corta	3
Manguera de entrada larga	5

La manguera de entrada larga se vende por separado

CONEXIÓN DEL SISTEMA DE DESAGÜE AL APARATO PRINCIPAL

1. Lavadora de carga frontal y pedestal lavador con secadora.

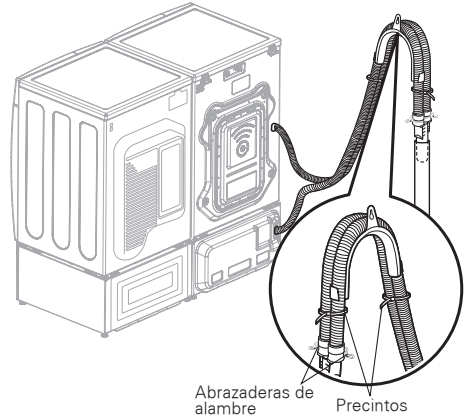

2. Lavadora de carga frontal y pedestal lavador con secadora híbrida.

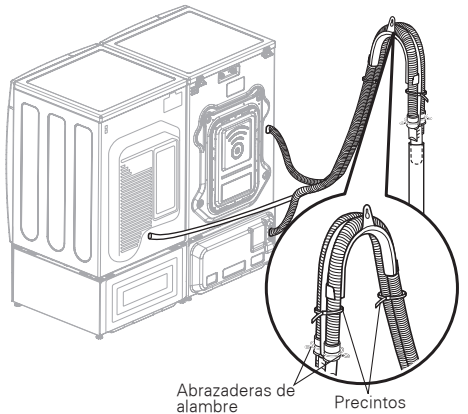

DETALLE DE LA CONEXIÓN DE LA MANGUERA DE DESAGÜE

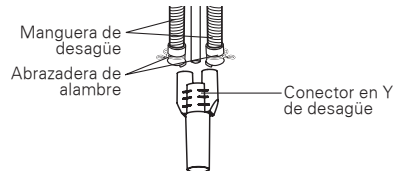

Para tubos verticales angostos, inserte la manguera de desagüe de la secadora híbrida en el centro del conector de desagüe. NO inserte la manguera de desagüe de la secadora más de 1" (2,5 cm). Utilice los precintos para sujetar las mangueras en su lugar.

CONEXIÓN DEL SUMINISTRO DE AGUA

- LG recomienda el uso de mangueras LG. Los daños materiales o en la lavadora provocados por una fuga debidos a una mala instalación o por el uso de mangueras de otro fabricante, no estarán cubiertos por la garantía LG y serán de exclusiva responsabilidad del cliente y/o instalador.
- La presión de las tuberías de agua debe ser entre 20 psi y 120 psi (138 - 827 kPa). Si la presión de la tubería de agua es superior a 120 psi, instalar una válvula reductora de presión.
- Revise periódicamente las mangueras por si hubiera grietas, fugas y desgaste, y sustitúyalas si fuese necesario.
- Asegúrese de que las tuberías de agua no están demasiado tensas, retorcidas o aplastadas.
- Almacene e instale la lavadora en un lugar no expuesto a temperaturas inferiores a las de congelación. Pueden provocar daños a las tuberías y mecanismos internos. Si la lavadora ha estado expuesta a temperaturas bajo cero antes de la instalación, déjela reposar a temperatura ambiente durante unas horas antes de su utilización y compruebe que no haya fugas.

NOTA: No utilice mangueras anti-desbordamiento con dispositivos de corte automático. Estos dispositivos pueden activarse durante el llenado y evitar que la lavadora se llene adecuadamente.

1. Revise la conexión roscada de las mangueras y asegúrese de que haya una junta de goma en ambos extremos de cada manguera.

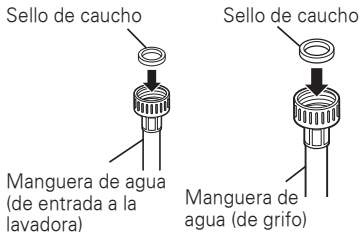

2. Conecte las tuberías de agua a las llaves de paso de agua caliente y fría y apriete las conexiones con la mano. A continuación, utilice unos alicates para apretarlas otro 2/3 de vuelta.

⚠ ADVERTENCIA

- **No apriete las mangueras en exceso.** Pueden producirse daños en el empalme.

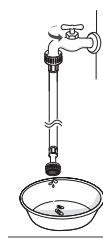
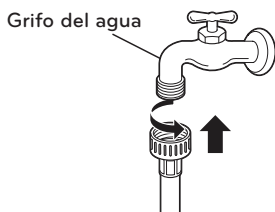

3. Deje salir el agua de la manguera para eliminar la suciedad, arena o serrín de las tuberías. Hacerlo le ayudará a evitar futuras obstrucciones del filtro y le permitirá verificar que tubería de agua es la caliente o fría.

4. Conecte la tubería de agua caliente a la llave de paso de agua caliente en la parte posterior de la lavadora. Conecte la tubería de agua fría a la llave de paso de agua fría en la parte posterior de la lavadora. Apriete correctamente las conexiones. Abra ambas llaves y compruebe que no haya fugas.

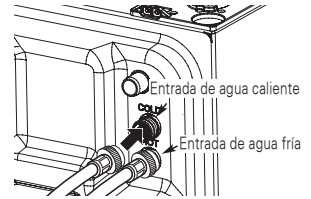

⚠ ADVERTENCIA

- **No reutilice mangueras viejas.** Utilice mangueras nuevas para la instalación de la lavadora. Las mangueras viejas pueden tener fugas o reventar causando inundaciones y daños materiales.

NOTA: Manipule cuidadosamente la rosca de los accesorios de la manguera; de lo contrario, podría averiarse y dañar las válvulas, causando fugas y daños materiales.

CONEXIÓN DE LA MANGUERA DE DESAGÜE

- La manguera de desagüe debe ajustarse correctamente. No ajustar correctamente la manguera de desagüe puede provocar inundaciones y daños a la propiedad
- El sistema de desagüe debe ser conforme a las regulaciones nacionales y locales aplicables.
- Asegúrese de que la manguera de desagüe no esté demasiado tensa, retorcida o aplastada.

CONEXIÓN DE LA MANGUERA DE DESAGÜE DEL PEDESTAL LAVADOR

1. Inserte la abrazadera de banda (incluida en la caja de embalaje) en el codo de la manguera de desagüe.



2. Con la manguera apuntando hacia arriba desde el codo, inserte el codo en la salida de desagüe que se encuentra en la parte posterior del pedestal lavador.

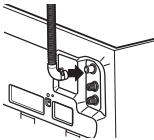

3. Ajuste la abrazadera de banda con una pinza para sujetar la manguera firme en su lugar y evitar fugas.

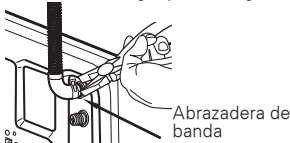

USO DEL CONECTOR DE DESAGÜE

- Conecte la manguera de desagüe de la lavadora de tamaño completo y del pedestal lavador con el conector de desagüe. Coloque las abrazaderas de alambre incluidas en los extremos de las dos mangueras de desagüe. Empuje las mangueras firmemente dentro del conector de desagüe. Ajuste las abrazaderas de alambre de la manguera para evitar que las mangueras se aflojen o que se produzcan fugas. En caso de que estas no se ajusten correctamente se pueden producir inundaciones. El conector de desagüe ayuda a evitar la presión excesiva, los olores y el desagüe inadecuado.

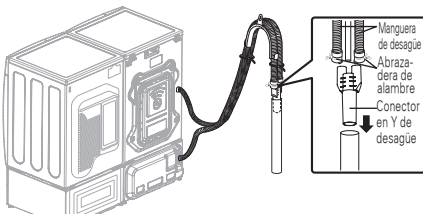

OPCIÓN 1: TUBO INDEPENDIENTE

Doble el extremo de salida de la manguera de desagüe hasta formar una U. Inserte el extremo de la manguera de desagüe en el

desagüe. Use los tres precintos incluidos con los materiales de instalación en la base de espuma del tambor para asegurar las mangueras de desagüe entre ellas y al desagüe. Consulte la sección Descripción general de conexiones para obtener más detalles. Si las llaves de paso de agua y el desagüe están empotradas en la pared, fije la manguera de desagüe a una de las mangueras de agua con el soporte de codo (lado rugoso hacia el interior).

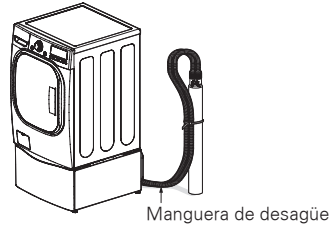

NOTA:

- La altura normal del extremo de la manguera debe ser aproximadamente 35" ~ 47" (0,9 ~ 1,2 m) desde el suelo.
- No instale el extremo de la manguera de desagüe más bajo de 29 pulg. (73,7 cm) o más alto de 96 pulg. (243,8 cm) con respecto a la base de la lavadora o a una distancia superior a 60 pulg. (152,4 cm) de la lavadora.
- No cree una junta hermética entre la manguera y el desagüe, por ejemplo, con cinta. Si no hay algo de aire, el agua puede ser desviada del tambor dando como resultado un mal lavado / aclarado o dañar la ropa.
- Para un mejor rendimiento, si posee una manguera de desagüe adicional de una secadora híbrida, colóquela en el tubo independiente, a un lado del conector de desagüe.
- Si el tubo independiente es demasiado angosto para alojar el conector de desagüe y la manguera de la secadora, puede insertar la manguera de la secadora hasta 3/4 pulg. en el centro del canal del conector de desagüe. Consulte la sección Descripción general de conexiones en la página 10.

⚠ PRECAUCIÓN

- Insertar la manguera de desagüe de la secadora a más de 3/4 pulg. causará fugas y un desagüe incorrecto.

• OPCIÓN 2: LAVABO

Doblar el extremo de la manguera de desagüe en la forma deseada y apoyarlo en el borde del lavado. Utilice una brida para fijar la manguera de desagüe en su posición.

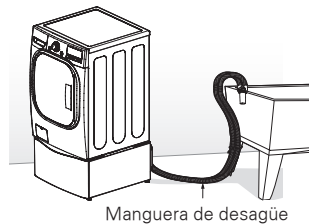

NOTA:

- No utilice esta manguera de desagüe con un desagüe de suelo. El extremo de la manguera debe situarse al menos 29 pulgadas por encima del suelo para lograr un vaciado adecuado.

NIVELACIÓN DE LA LAVADORA

El tambor de su nueva lavadora gira a alta velocidad. Para reducir las vibraciones, el ruido y los movimientos no deseados, el suelo debe estar nivelado y debe ser una superficie sólida.

- Compruebe que la lavadora esté nivelada.
 - Compruebe la nivelación meciendo los extremos superiores de la lavadora o colocando un nivel sobre la máquina. La inclinación debajo de la lavadora no debe ser superior a 1°, y las cuatro patas deben estar firmemente apoyadas en el suelo.

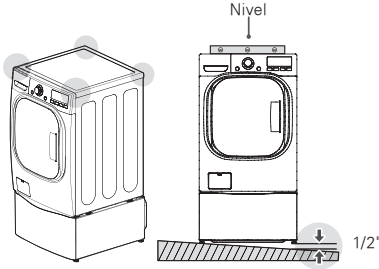

- Gire las patas de nivelación de la lavadora en sentido de las manecillas del reloj para nivelarla.
 - Gire las patas de nivelación de la lavadora en sentido de las manecillas del reloj para levantar la lavadora.

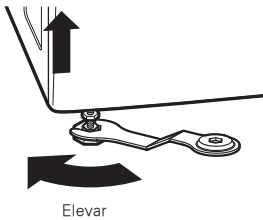

- Gire las contratuercas en sentido contrario a las manecillas del reloj y apriételas cuando la lavadora esté nivelada.

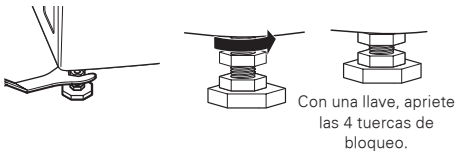

- Compruebe de nuevo que la lavadora esté nivelada.
 - Empuje o sacuda los extremos superiores de la lavadora suavemente para asegurarse que la máquina no esté meciéndose.
 - En caso que la lavadora esté meciéndose, repita los pasos 1 a 3.

⚠️ PRECAUCIÓN

- Si utiliza la lavadora sin nivelarla, pueden producirse fallos de funcionamiento causados por el exceso de vibraciones y ruido.
- Cuando coloque la lavadora de tamaño completo sobre el pedestal lavador, utilice las patas de nivelación del pedestal lavador para nivelar ambos aparatos. Las patas de nivelación de la lavadora de tamaño completo deben reducirse y luego asegurarse haciendo girar las tuercas en el sentido contrario de las manecillas del reloj.
- **Utilice las patas de nivelación sólo para nivelar la lavadora.** Si eleva las patas de nivelación de forma innecesaria, puede causar vibraciones anómalas de la lavadora.

USO DE ALMOHADILLA ANTIDESLIZANTE (OPCIONAL)

Si instala la lavadora sobre una superficie resbaladiza, la misma podría moverse debido a las vibraciones excesivas. La nivelación incorrecta puede causar fallos de funcionamiento debido a los ruidos y vibraciones. En este caso, coloque los apoyos antideslizantes bajo las patas niveladoras y ajuste el nivel.

- Limpie el suelo antes de colocar los apoyos antideslizantes.
 - Utilice un trapo seco para eliminar y limpiar los objetos extraños o la humedad. Si queda humedad, podrían resbalar los apoyos antideslizantes.
- Ajuste el nivel tras colocar la lavadora en el área de instalación.
- Coloque el lado adhesivo del apoyo antideslizante sobre el suelo.
 - La forma más efectiva de instalación de los apoyos antideslizantes es bajo las patas delanteras. Si es difícil colocar los apoyos bajo las patas delanteras, colóquelas bajo las patas traseras.

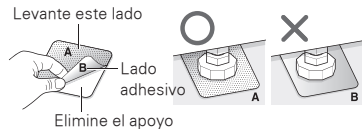

- Compruebe de nuevo que la lavadora esté nivelada.
 - Empuje o sacuda los bordes superiores de la lavadora de manera suave para asegurarse que no se balancee. Si la lavadora se balancea, vuelva a nivelarla.

CONEXIÓN A LA RED ELÉCTRICA

La lavadora deberá estar conectada a una toma de corriente de 120 VCA, 60 Hz. de 3 clavijas con conexión a tierra. Conecte la lavadora. Conecte a la toma eléctrica sin ninguna conexión a tierra adicional. La conexión incorrecta del conductor de tierra puede causar riesgo de descargas eléctricas. Consulte a un electricista o técnico calificado si tiene dudas acerca de la correcta conexión a tierra del aparato. No modifique el enchufe incluido con el aparato. Si la toma no es compatible, solicite la instalación de una toma adecuada a un electricista calificado. El incumplimiento de estas advertencias puede causar lesiones graves o mortales, un incendio o descargas eléctricas.

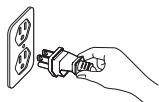

⚠️ ADVERTENCIA

- **La toma de corriente debe estar dentro de un área mínima de 60 pulgadas (1,5 m) a cualquiera de los lados de la lavadora.**
- **El aparato y la toma eléctrica deberán colocarse de modo que pueda accederse fácilmente al enchufe.**
- **Conecte la lavadora a una toma de corriente con un voltaje que coincida con la placa de datos técnicos.** Para un mejor rendimiento, conecte la lavadora en una toma de corriente individual exclusiva. Esto ayuda a evitar la sobrecarga de los circuitos eléctricos de la casa, lo que podría causar un peligro de incendio por sobrecalentamiento de los cables. Si fuera necesario, utilice un adaptador de 3 clavijas o un cable de extensión de 3 conductores con un enchufe de 3 clavijas (conexión a tierra) nuevos y homologados por UL y con una clasificación que no sea menor que la del circuito derivado. No utilice un cable de extensión de una longitud mayor a tres pies. El incumplimiento de estas advertencias puede causar lesiones graves, incendios, descargas eléctricas o la muerte.
- **La puesta a tierra de la toma de corriente será conforme a los códigos y las regulaciones locales.**
- Se recomienda un fusible de demora de tiempo o disyuntor.
- Es responsabilidad y obligación personal del dueño del producto pedir a un electricista calificado que instale la toma de corriente adecuada.
- **No utilice un cable o enchufe dañados o desgastados. Repare o sustítúyalos de inmediato.** De lo contrario, podría sufrir lesiones mortales, o causar un incendio, descargas eléctricas o fallos de funcionamiento.
- **No modifique el cable de alimentación y tenga cuidado de no dañarlo durante la instalación o traslado de la lavadora.** De lo contrario, podría sufrir lesiones mortales, o causar un incendio, descargas eléctricas o fallos de funcionamiento.
- **Asegúrese de que la lavadora esté conectada a tierra.**
- **Conecte esta lavadora a una toma eléctrica con conexión a tierra y compruebe previamente su placa de características.** De lo contrario, podría producirse un incendio, descargas eléctricas o fallos de funcionamiento.
- **No utilice adaptadores o alargaderas.** La lavadora debe conectarse siempre en su propia toma eléctrica individual, con la misma tensión a la indicada en la placa de características. De lo contrario, podría producirse un incendio, descargas eléctricas o fallos de funcionamiento.
- **No dañe o corte el terminal de tierra del enchufe.** Puede causar un incendio, descargas eléctricas o dañar el producto.

CLASIFICACIÓN DE LAS CARGA DE LAVADO

⚠️ PRECAUCIÓN

- Compruebe que no haya ningún objeto extraño en la junta superior de la puerta. El incumplimiento de esta precaución puede causar fugas o daños en la ropa.
- Utilice el ciclo Bedding de cama para los artículos pesados o no absorbentes como almohadas o edredones. El incumplimiento de esta precaución puede causar fugas.
- Si es posible, no lave prendas impermeables. Si tiene que hacerlo, seleccione el Waterproof de cama. (es decir, ropa resistente al agua, fundas de colchón, ropa para exterior, alfombrillas de plástico, etc.)
- Si se lavan materiales impermeables en un ciclo que no sea Impermeable, podría sufrir lesiones o dañar la lavadora, la ropa, las paredes, el suelo u objetos alrededor a causa de las vibraciones anómalas.

CLASIFICAR EN CARGAS SIMILARES

Para obtener mejores resultados de lavado y reducir la posibilidad de dañar la ropa, clasifique cuidadosamente la ropa en cargas similares.

La mezcla de diferentes tipos de prendas y/o niveles de suciedad puede provocar un mal resultado de lavado, la transferencia de los colores, pelusas, decoloración o daños en los tejidos. Clasificar las prendas en grupos como se describe a continuación.

COLORES

Ordene los artículos por colores. Separe los colores oscuros de los claros y prendas blancas. La mezcla de prendas oscuras y claras puede provocar la decoloración o el teñido de las prendas más claras.

NIVEL DE SUCIEDAD

Lave la ropa muy sucia en una misma carga. Lavar la ropa poco sucia con ropa muy sucia puede afectar negativamente al rendimiento de lavado.

TIPO DE TEJIDO

No mezcle prendas delicadas con prendas más pesadas o resistentes. Mezclar prendas pesadas con otras delicadas puede provocar que las prendas pesadas no queden suficientemente limpias y dañar a las delicadas.

TIPO DE PELUSA

En el proceso de lavado, mientras algunos tejidos producen pelusa otros la recogen. No mezcle tejidos recogedores y productores de pelusa en la misma carga. La mezcla de estos tejidos puede provocar la formación de bolas y pelusa en los tejidos recogedores de pelusa. (Por ejemplo, tejido recogedor de pelusa - suéter de punto; tejido productor de pelusa - toallas de felpa.)

ETIQUETAS...

Colores	Suciedad	Tejidos	Pelusa
Blanco	Muy sucio	Delicados	Productores de pelusa
Claros	Normal	Normales	Recogedores de pelusa
Oscuros	Luz	Resistentes	

ETIQUETAS DE CUIDADO DE LA ROPA

La mayoría de las prendas de vestir llevan etiquetas. Consulte el cuadro siguiente para clasificar la ropa según las recomendaciones del fabricante.

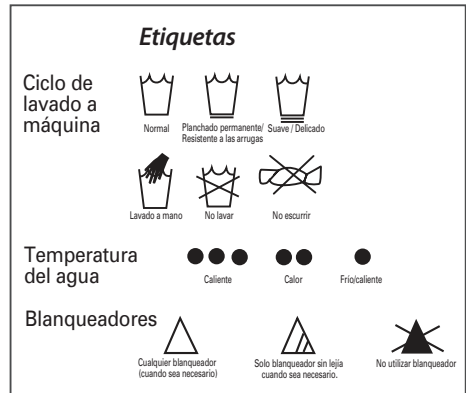

CARGA DE LA LAVADORA

- Revise todos los bolsillos para asegurarse de que estén vacíos. Artículos como clips, cerillas, plumas, monedas y llaves pueden dañar su lavadora o sus prendas.
- Cierre las cremalleras, ganchos y cordones para prevenir que estos artículos se enganchen o enreden en otras prendas.
- Realice un pretratamiento de las áreas más sucias antes del lavado.
- Para evitar un desequilibrio en el tambor, no lave prendas sueltas. Asegúrese de lavar la ropa en tipos similares de cargas. Lavar individualmente las prendas grandes y voluminosas, como mantas, edredones o colchas.
- La lavadora no se llenará ni funcionará con la puerta abierta.
- No sobrecargue el tambor. Las prendas deben caber de manera holgada en el tambor por debajo de la línea de llenado máximo. Cargar prendas por encima de la línea de llenado puede causar daños a las prendas o a la lavadora.

⚠️ PRECAUCIÓN

- Cierre la tapa hasta que haga clic antes de cerrar el cajón para comenzar el ciclo.
- Presione para abrir la tapa. No fuerce la tapa de la lavadora para abrirla. Hacerlo puede dañar el aparato.

USO DE DETERGENTE Y BLANQUEADOR

UNA PALABRA SOBRE DETERGENTES

Los detergentes de alta eficiencia (HE, por sus siglas en inglés) producen menos espuma, se disuelven mejor para mejorar el desempeño de lavado y aclarado, y ayudan a mantener limpio el interior de la lavadora. El empleo de un detergente que no sea de alta eficiencia puede producir demasiada espuma y un mal desempeño que podrían causar errores, fallas en los ciclos y daños a la máquina.



Esta máquina necesita muy poco detergente. Para lograr un buen desempeño de lavado, siempre use el dosificador y el dispositivo de medición provisto con la máquina.

El compartimento contiene un máximo de 2 cucharaditas (10 g/10 cc) de detergente HE. La mayoría de las cargas normales requieren solo 1 cucharadita (5 g/5 cc) de detergente o que se llene el dosificador hasta la línea de la mitad.

El uso de demasiado detergente puede producir espuma excesiva y un mal desempeño. Reduzca la cantidad de detergente o agregue un aclarado extra si queda residuo de detergente en las telas. Para agregar un aclarado extra, presione el botón Extra Rinse.



DISEÑO ÚNICAMENTE PARA EL USO DE DETERGENTES DE ALTA EFICIENCIA. (HE: HIGH-EFFICIENCY)

IMPORTANTE: Su lavadora está diseñada únicamente para el uso de detergentes de Alta Eficiencia (HE: High-Efficiency). Los detergentes de Alta Eficiencia están formulados específicamente para lavadoras de alta eficiencia y contienen agentes de reductores de espuma. Busque siempre el símbolo de HE en la compra de detergente.

IMPORTANTE: No todos los detergentes son iguales. Preste especial atención a la cantidad de detergente que se usa para evitar el exceso de espuma. Un mal aclarado y detergente o residuos acumulados en la ropa pueden contribuir a los olores en la máquina. NO utilice medidas que no sean las suministradas por el fabricante del detergente. No utilice una cantidad superior a la máxima recomendada por el fabricante del detergente. Sólo se necesita una cucharada o medida completa de detergente para cargas de ropa muy sucia. Si utiliza demasiado detergente, podría acumularse en la lavadora y en la ropa.

Mida siempre la cantidad de detergente. Ya que los detergentes de Alta Eficiencia están diseñados para este tipo de lavadora, tenga cuidado al medir el detergente. Para la mayoría de las cargas no se debe utilizar más de 1/4 a 1/2 del tapón o una cucharada de detergente HE.

NOTA:

- Se debe tener especial cuidado al utilizar detergentes concentrados 2x y 3x porque añadir poco más puede producir los problemas mencionados anteriormente.
- Ciertos detergentes considerados como compatibles con HE pueden no proporcionar los mejores resultados.

USO DEL DETERGENTE

1. Deslice el cajón para abrirlo, abra la tapa y agregue la ropa en la cuba.
2. Mida el detergente con el dosificador de detergente y viértalo en la cuba.
3. Cierre la tapa, deslice el cajón para cerrarlo y presione START/PAUSE para iniciar el ciclo.

NOTA: No se debe usar blanqueador con cloro líquido o en polvo en el pedestal lavador. Para blanquear la ropa, use la lavadora principal y siga las instrucciones del manual del propietario para dicha máquina.

IMPORTANTE: No coloque ni almacene productos de lavandería, como detergente, blanqueador o suavizante líquido, en la parte superior de la lavadora o la secadora. Limpie los productos derramados inmediatamente. Estos productos pueden dañar el acabado de la superficie y los controles.

USO DE BLANQUEADOR

No use blanqueador con cloro líquido o en polvo en el pedestal lavador. Para blanquear ropa, use la lavadora principal y siga las instrucciones del manual del propietario que se incluye con dicha máquina.

USO DE SUAVIZANTE

El pedestal lavador suena varias veces antes del aclarado final, de modo que se pueda agregar suavizante líquido a la carga si se desea. Cuando la máquina suena, presione Start/Pause para pausar el ciclo.

1. Deslice el cajón para abrirlo, abra la tapa y agregue el suavizante líquido en el dosificador de detergente. El suavizante también puede diluirse con agua y agregarse directamente en la cuba. No vierta suavizante sin diluir directamente sobre la ropa porque podría manchar las telas.
2. Cierre la tapa, deslice el cajón para cerrarlo y presione Start/Pause para reiniciar el ciclo.
3. Para activar o desactivar el alerta del suavizante, mantenga presionados los botones Warm Water y Extra Rinse al mismo tiempo durante tres segundos.

NOTA : Si no pudo escuchar el alerta para agregar suavizante, aclare una vez más usando el ciclo Rinse+Spin.

MODO DE UTILIZACIÓN

CARACTERÍSTICAS DEL PANEL DE CONTROL

WD205C*

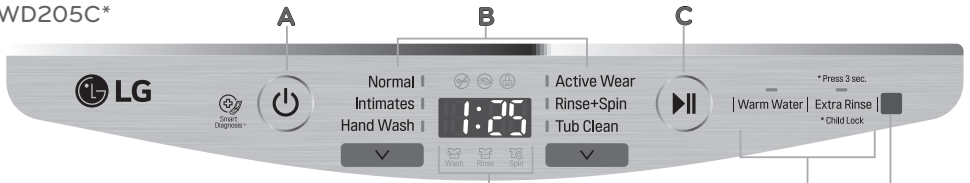

WD100C*/WD200C*

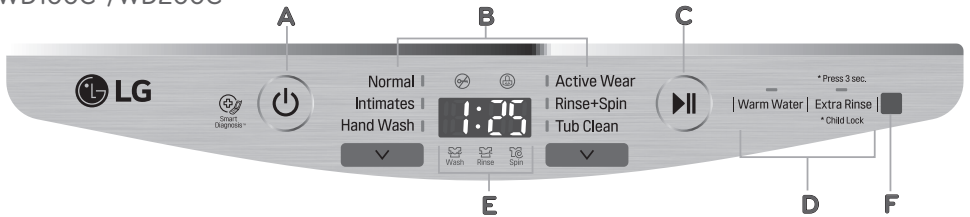

A BOTÓN POWER (ENCENDIDO/APAGADO)

Pulse para ENCENDER la unidad. Presione el botón POWER para apagar la lavadora. Al pulsar el botón POWER durante un ciclo cancelará ese ciclo y se perderán los ajustes de carga. La puerta se desbloqueará después de una breve pausa.

NOTA:

- Cuando se pulsa el botón Power, no se selecciona ningún ciclo de forma predeterminada. Pero, para seleccionar el Ciclo Normal, debe girar el mando selector para que se encienda la luz del Ciclo Normal y activar las opciones de ajuste.

B SELECTOR DE CICLOS

Gire el mando selector hasta situarlo en el ciclo deseado. Una vez que se ha seleccionado el ciclo, en la pantalla se visualizan los preajustes estándar. Esta configuración se puede modificar mediante los botones antes de comenzar el ciclo.

NOTA: Para proteger su ropa, no todas las velocidades de centrifugado están disponibles para todos los ciclos..

C BOTÓN INICIO/PAUSA

Mantenga pulsado este botón más de 0,4 segundos para iniciar el ciclo seleccionado. Si la lavadora está en funcionamiento, use este botón para pausar el ciclo sin perder la configuración actual.

NOTA: Si no pulsa el botón INICIO/PAUSA en 4 minutos tras la selección de un ciclo, la lavadora se APAGARÁ automáticamente y se perderán los ajustes del ciclo.

D BOTONES MODIFICADORES DE CICLO

Utilice estos botones para realizar los ajustes del ciclo seleccionado. Los pilotos luminosos situados encima de los botones se iluminan para mostrar la selección.

E CICLO ESPECIAL Y BOTONES OPCIONALES

Estos botones le permiten seleccionar ciclos u opciones especiales.

F SENSOR DEL CONTROL REMOTO

Utilice el control remoto para ajustar los controles sin tener que agacharse para poder alcanzar el panel de control.

PANTALLA DE TIEMPO Y ESTADO

La pantalla muestra el tiempo restante estimado y el progreso del ciclo.

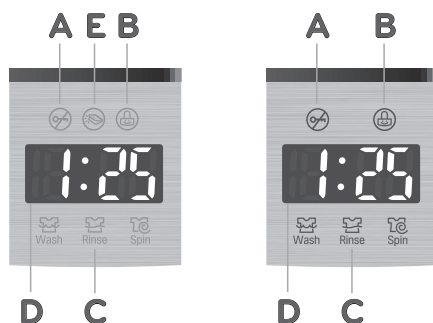

A INDICADOR DE BLOQUEO DEL CAJÓN

El indicador de BLOQUEO DEL CAJÓN se iluminará cuando el ciclo haya comenzado. La luz del indicador permanecerá encendida hasta que el ciclo se pause, se detenga o finalice.

B SEGURO PARA NIÑOS

Cuando se activa el Seguro para niños, se ilumina el indicador LED. Cuando se establece la función del Seguro para niños, se deshabilitan las demás funciones, excepto por el botón de ENCENDIDO. Cuando se deshabilita la función del Seguro para niños, el indicador LED se apaga.

C INDICADOR DEL ESTADO DEL CICLO

Estos indicadores LED se iluminan cuando se selecciona un ciclo para señalar las etapas que van a ejecutarse. Cuando un ciclo está en ejecución, parpadea el indicador LED para la etapa activa y los indicadores LED para las etapas restantes permanecerán fijos. Cuando se completa una etapa, el indicador LED se apaga. Si se pausa un ciclo, el indicador LED de la etapa activa deja de parpadear.

D TIEMPO RESTANTE ESTIMADO

Cuando se selecciona un ciclo, aparece el tiempo predeterminado para ese ciclo. Este tiempo cambia a medida que se seleccionan modificadores u opciones.

NOTA: El tiempo que se muestra es solo una estimación. Este tiempo se basa en condiciones normales de funcionamiento. Varios factores externos (como el tamaño de la carga, la temperatura ambiente, la temperatura del agua entrante, la presión del agua, etc.) pueden afectar el tiempo real.

E TAPA ABIERTA

Si la tapa está abierta, el indicador LED parpadea. Cierre la tapa y el cajón y presione START/PAUSE (INICIAR/PAUSAR) para iniciar el ciclo. Algunos modelos no cuentan con el indicador de TAPA ABIERTA. Si la tapa está cerrada y aparece el mensaje de error en la tapa, llame al servicio técnico.

FUNCIONAMIENTO DE LA LAVADORA

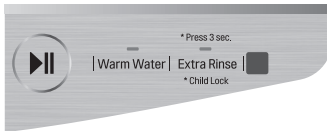

- 1 CLASIFICACIÓN Y CARGA DE LA LAVADORA**
 Dependiendo de la necesidad, clasifique la ropa según tipo de tejido, nivel de suciedad, color o tamaño de la carga. Abra la tapa y cargue las prendas en la lavadora.
- 2 PRODUCTOS DE LIMPIEZA**
 Mida el detergente de alta eficiencia (HE) con el dosificador y viértalo, y cargue el recipiente en la lavadora.
- 3 ENCENDIDO DE LA LAVADORA**
 Presione el botón POWER para encender la lavadora. La luz de los ciclos se encenderá y sonará una alarma. Se iluminarán las luces del ciclo y sonará una alarma.
- 4 SELECCIÓN DE UN CICLO**
 Presione el botón selector de ciclos para seleccionar el ciclo deseado. Cuando presiona Power, se selecciona el ciclo Normal de manera predeterminada. Para modificar las opciones, presione el botón selector de ciclos para activar la pantalla. También puede usarse el control remoto para seleccionar el ciclo deseado.
- 5 CONFIGURACIÓN DE AJUSTE**
 En este momento, pueden modificarse las configuraciones predeterminadas del ciclo seleccionado si se desea. Para ello, use los botones de modificación de ciclo.

NOTA: No todos los modificadores están disponibles para todos los ciclos. Sonará una alarma diferente y la luz no se encenderá si la selección no está permitida.
- 6 COMIENZO DEL CICLO**
 Inserte la abrazadera de banda (incluida en la caja de embalaje) en el codo de la manguera de desagüe. Presione START/PAUSE para comenzar el ciclo. El cajón se traba y la lavadora comienza el ciclo. Si no se presiona el botón START/PAUSE antes de 4 minutos, la lavadora se apaga y se pierden todas las configuraciones.
- 7 AGREGUE SUAVIZANTE**
 Antes del aclarado final, una alarma suena repetidamente. Cuando suene la alarma, pause la máquina y agregue el suavizante líquido, si lo desea, antes de que pasen 3 minutos.
- 8 FIN DEL CICLO**
 Cuando el ciclo haya terminado, sonará una melodía. Saque inmediatamente la ropa de la lavadora para reducir las arrugas.

⚠ ADVERTENCIA

- Para reducir el riesgo de incendio, cortocircuito o lesiones personales, **lea las INSTRUCCIONES IMPORTANTES DE SEGURIDAD antes de utilizar este aparato.**

GUÍA DE CICLOS

La guía de ciclos que aparece a continuación muestra la configuración predeterminada, las opciones disponibles y los tipos de tejidos recomendados para cada ciclo. Debajo de la configuración predeterminada de cada ciclo figuran los ajustes y modificaciones permitidos.

		Key			
		Valor predeterminado			
		☉		Opción disponible	
Ciclo	Uso de Ciclo	Tiempo Estimado	Temperatura de Lavado	Aclarado Extra	Bloqueo Infantil
Normal (Normal)	Algodón levemente sucio, camisetas, toallas, vaqueros, bóxers, cargas mixtas, etc.	39 ~ 116	Agua templada	☉	☉
			Agua fría		
Intimates (Ropa Delicada)	Lencería, ropa interior, ropa para dormir, etc.	47 ~ 103	Agua templada	☉	☉
			Agua fría		
Hand Wash (Lavado a mano)	Sweater, knit, cardigan, items labeled "hand washable" etc.	47 ~ 103	Agua templada	☉	☉
			Agua fría		
Active Wear (Ropa Deportiva)	Especialmente para ropa con diseño/tratamiento especial.	43 ~ 103	Agua templada	☉	☉
			Agua fría		
Rinse + Spin (Aclarado + Centrifugado)	Tratamiento previo para manchas, o enjuague del jabón y desagüe de la cuba	8 ~ 90		☉	☉
Tub Clean (Limpieza de cuba)	Limpia la cuba y quita el olor a humedad.	58	Agua templada		☉
			Agua fría		

CICLOS DE LAVADO

Los ciclos de lavado se han diseñado para lograr los mejores resultados para cada tipo de carga. Seleccione el ciclo más adecuado para sus prendas y, de este modo, logrará mejores resultados y un mayor cuidado de los tejidos. Gire el mando selector hasta el ciclo deseado. Cuando pulse el botón de selección de ciclo de lavado, se iluminará el piloto del ciclo de lavado correspondiente. Consulte en la página 19, **FUNCIONAMIENTO DE LA LAVADORA**, más información sobre los métodos de funcionamiento.

Normal (Normal)

Use este ciclo para el lavado de prendas normales, excepto tejidos delicados como lana o seda.

NOTA: Si pulsa el botón INICIO/PAUSA sin seleccionar un ciclo, comenzará automáticamente el programa NORMAL con los ajustes predefinidos.

Intimates (Ropa Delicada)

Use este ciclo para lavar prendas delicadas como lencería o prendas con encaje y transparentes que podrían dañarse fácilmente en un ciclo normal. Este ciclo no es para prendas de seda.

Hand Wash (Lavado a mano)

Use este ciclo para lavar prendas que se lavan a mano o de lana que se encoge y que requiere un tratamiento delicado. Solo lave prendas de lana que tengan la etiqueta de lavado a máquina o a mano.

Active Wear (Ropa Deportiva)

Use este ciclo para lavar prendas de alto desempeño que están diseñadas y tratadas especialmente para el deporte.

Rinse + Spin (Aclarado + Centrifugado)

Seleccione esta opción para aclarar y centrifugar una carga sin realizar un ciclo regular. Esto previene la permanencia de ciertos tipos de mancha en los tejidos. Para cambiar la velocidad de centrifugado, pulse el botón Rinse+Spin.

Spin Only Cycle (Ciclo Solo Centrifugado)

Para activar el ciclo de centrifugado solo, seleccione el ciclo Rinse+Spin. Luego presione el botón Extra Rinse seis veces o hasta que, en la pantalla, aparezca 8 y el icono Rinse ya no esté encendido en el panel.

Tub Clean (Limpieza de cuba)

Use este ciclo para limpiar la cuba de la lavadora.

OPTIONS (OPCIONES)

Tras seleccionar un ciclo, pulse el botón Other Use para seleccionar características de lavado adicionales.

NOTA:

- Para proteger sus prendas de vestir no todas las opciones están disponibles en todos los ciclos.
- Si no pulsa el botón INICIO/PAUSA transcurridos 4 minutos para iniciar el ciclo, se apagará la lavadora y se perderán todos los ajustes.

WARM WATER (AGUA TEMPLADA)

La opción de agua caliente se selecciona de forma predeterminada en los ciclos Normal e Intimates. Puede deshacer la selección si pulsa el botón Warm Water. La temperatura del agua no puede regularse en los ciclos Rinse + Spin.

EXTRA RINSE (ACLARADO EXTRA)

Esta opción añadirá un aclarado extra al ciclo seleccionado. Use esta opción para ayudar a eliminar el residuo de detergente o blanqueador de las telas. Suena una alarma varias veces durante unos 20 segundos antes del aclarado final, de modo que pueda pausarse la máquina y agregar suavizante si se desea.

NOTA:

- No puede seleccionar la opción Extra Rinse con la opción Rinse+Spin ni con el ciclo Tub Clean.
- Si el ciclo Rinse+Spin está seleccionado y presiona Extra Rinse seis veces, se seleccionará el ciclo Spin only.

Child Lock (Bloqueo para niños)

Utilice esta opción para desactivar los controles. Esta función evita que los niños cambien los ciclos o utilicen la lavadora. Una vez que se establece la función Child Lock, la misma debe desactivarse para poder usar los controles, excepto en el caso del botón Power. Una vez que haya finalizado el ciclo, la máquina se mantendrá ENCENDIDA, pero los controles continuarán bloqueados. Con los controles bloqueados, CL se muestra alternativamente con el tiempo restante. Mantenga pulsado el botón Water Plus durante 3 segundos para activar o desactivar el bloqueo infantil.

NOTA:

- Una vez bloqueados los controles, deberán desbloquearse manualmente para reanudar el funcionamiento.

CUIDADO Y LIMPIEZA

⚠️ ADVERTENCIA

Antes de utilizar la lavadora, para minimizar el riesgo de incendio, descarga eléctrica o prevenir lesiones, lea completamente el Manual del usuario, incluyendo las normas importantes de seguridad.

- Antes de su limpieza desconecte la lavadora para evitar el riesgo de descarga eléctrica. El incumplimiento de esta advertencia puede causar lesiones graves o mortales, un incendio o descargas eléctricas.
- No utilice productos químicos abrasivos, limpiadores abrasivos o disolvente para limpiar la lavadora. Podrían dañar el acabado.

LIMPIEZA REGULAR

LIMPIEZA DEL EXTERIOR

Limpie el exterior de la máquina con agua tibia y un detergente suave, no abrasivo. Limpie inmediatamente todo líquido derramado con un paño suave y húmedo.

IMPORTANTE: No use disolventes, alcohol o productos similares. No utilice lana de acero ni limpiadores abrasivos ya que pueden dañar la superficie.

CUIDADO Y LIMPIEZA DEL INTERIOR

Use una toalla o paño suave para limpiar alrededor de la puerta y el cristal.

Vaciar la lavadora una vez finalizado el ciclo de lavado. Mantener ropa húmeda en la lavadora puede causar arrugas, transferencia de colores, y malos olores. Ejecute el ciclo Tub Clean una vez al mes, o con mayor frecuencia si fuera necesario, para eliminar los restos de detergente y de otro tipo.

CICLO DE LIMPIEZA DE TAMBOR

Algunas condiciones medioambientales y de uso pueden causar la acumulación de residuos en el tambor con el paso del tiempo y producir un olor a moho o humedad. El ciclo Tub Clean ha sido especialmente diseñado para eliminar esta acumulación mediante el uso de lejía u otros limpiadores específicos para la limpieza de la máquina. Ejecute el ciclo Tub Clean una vez al mes o con mayor frecuencia si el olor persiste.

1. Retire toda la ropa del tambor.
2. Diluya 1/4 de taza de blanqueador (cloro líquido) en 1 cuarto de galón de agua y vierta la mezcla en la cuba. No use más de 1/4 de taza de blanqueador líquido.

NOTA: Para los productos de limpieza de tambores, siga las instrucciones y recomendaciones del fabricante. Para productos de limpieza en polvo, añada el limpiador al cajón dosificador de lavado principal tras retirar los restos de detergente líquido.

3. Cierre la puerta y presione POWER para ENCENDER la lavadora. Gire el selector hasta posicionarlo sobre el ciclo TUB CLEAN; a continuación pulse el botón START/PAUSE para iniciar el ciclo. En caso de seleccionar otro ciclo tras la selección del ciclo Tub Clean, éste se cancela.

4. Una vez finalizado el ciclo deje la puerta abierta hasta que el interior se seque por completo.

NOTA:

- Nunca meta prendas en la lavadora mientras utilice el ciclo de TUB CLEAN. La ropa puede dañarse o contaminarse con productos de limpieza. Asegúrese de realizar el ciclo Tub Clean SOLO con la cuba vacía.
- Se recomienda dejar la puerta abierta cuando haya terminado el lavado para mantener el tambor limpio.
- Se recomienda repetir el ciclo TUB CLEAN todos los meses.

ELIMINACIÓN DE DEPÓSITOS MINERALES

Si usted vive en un área con agua dura, puede acumularse la cal en los componentes internos de la lavadora. En estas zonas es recomendable utilizar productos para ablandar el agua.

Use un descalcificador, como Washer Magic®, para eliminar los restos de cal. Tras la descalcificación, realice un ciclo de Tub Clean, antes de realizar una colada.

Ciertos restos de minerales u otras manchas en el acero inoxidable pueden quitarse con un limpiador de acero inoxidable. NO utilice productos abrasivos o lana metálica.

DEJE LA PUERTA ABIERTA

Si la lavadora no se utilizará durante varios días, deje la tapa y el cajón abiertos para que la cuba se seque.

⚠️ PRECAUCIÓN

- No permita que niños ni mascotas jueguen en la lavadora o con ella. Deben estar supervisados cuando estén cerca de la lavadora abierta.

MANTENIMIENTO

LIMPIEZA DE LOS FILTROS DE ENTRADA DE AGUA

Si la lavadora no se llena correctamente, se mostrará un mensaje de error en la pantalla. El filtro de la válvula de entrada podría estar obstruido por incrustaciones, sedimentos u otros residuos.

NOTA: Los filtros de entrada protegen las partes delicadas de la válvula de entrada de los posibles daños causados por partículas que pudieran entrar en la válvula con el suministro de agua. No utilice la lavadora sin los filtros de entrada. En caso contrario podrían producirse fugas y/o daños.

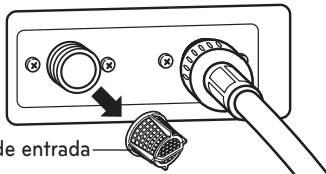
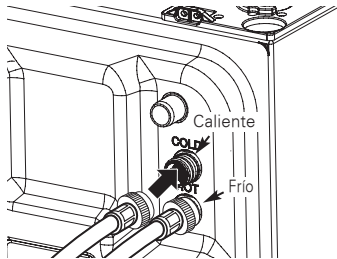

1. CERRAR los dos grifos de agua completamente. Suelte las mangueras de agua caliente y de agua fría de la parte posterior de la lavadora.

IMPORTANTE: No todas las mangueras disponibles en el mercado son válidas ni garantizan un correcto funcionamiento. Determinadas mangueras pueden no encajar correctamente y provocar fugas. Los daños provocados al producto o a la propiedad por este uso inadecuado no serán cubiertos por la garantía.

2. Retire con cuidado los filtros de las válvulas de agua y sumérgalos en vinagre o en algún producto para la eliminación de depósitos calcáreos, siguiendo las instrucciones del fabricante. Tenga cuidado de no dañar los filtros durante la limpieza.
3. Enjuáguelos bien antes de volver a instalarlos. Encaje los filtros en su posición.

4. Antes de volver a colocarlas, conecte las mangueras y tuberías a un grifo completamente abierto de manera que el flujo sea máximo y deje circular varios litros de agua a un balde o sistema de drenaje.

NOTA: Un mensaje *!E* parpadea en la pantalla cuando la presión del agua es baja o si un filtro de entrada está obstruido por la suciedad. Limpie el filtro de entrada.

⚠️ ADVERTENCIA

- **Desconecte el cable de alimentación y cierre los grifos antes de limpiar.** No hacerlo puede ser causa de descarga eléctrica.
- **No utilice la lavadora sin los filtros de entrada.** Utilizar la lavadora sin los filtros de entrada podría causar fugas y un mal funcionamiento.
- Utilizar la lavadora sin los filtros de entrada podría causar fugas y fallos de funcionamiento del producto.

GUARDAR LA LAVADORA

Siga las instrucciones para guardar la lavadora si no la va a utilizar durante un largo período de tiempo en climas fríos, con temperaturas bajo cero.

1. APAGAR el suministro de agua.
2. Desconecte las mangueras del suministro de agua y vacíe el agua.
3. Conecte el cable de alimentación a una toma eléctrica con conexión a tierra.
4. Añada 1 galón (3,8 litros) de anticongelante para vehículos recreativos (RV) no tóxicos en el tambor vacío de la lavadora y cierre la puerta. **Nunca** use anticongelante para automóviles.
5. Pulse el botón POWER y a continuación seleccione el ciclo Spin Only (ver página 21). Pulse el botón Start/Pause para activar la bomba de desagüe. Deje la bomba de desagüe funcionando durante un minuto y luego pulse el botón POWER para apagar la lavadora. Esto expulsará una cantidad de anticongelante y dejará solo el necesario para proteger la lavadora de posibles daños.
6. Desconecte el cable de alimentación, seque el interior del tambor con un paño suave y cierre la puerta.
7. Presione con fuerza para desenganchar el cajón dispensador de detergente y extráigalo. Escurra el agua de los compartimentos y deje que se sequen.
8. Guarde la lavadora en posición vertical.
9. Para eliminar el anticongelante tras guardar la lavadora, añada detergente al dispensador y ejecute un ciclo de Speed Wash.

ESPECIFICACIONES

Modelo : WD100C* / WD200C* / WD205C*	
Descripción	Lavadora de carga superior
Requisitos eléctricos	120 VAC @ 60 Hz.
Máx. Presión de agua	20~120 PSI (138~827kPa)
Dimensiones	WD100C* 27" (An) x 30 3/4" (F) x 14 1/8"(Al), 50 1/2"(F. Con el cajón abierto) WD200C* / WD205C* 29" (An) x 30 7/8" (F) x 14 1/8"(Al), 50 9/16"(F. Con el cajón abierto)
Peso neto	WD100C* 100lb(45.4kg) WD200C* 105lb(47.8kg) WD205C* 108lb(49.1kg)
Máx. Velocidad de centrifugado	700 rpm

SISTEMA SMART DIAGNOSIS™

Si experimenta algún problema con la lavadora, podrá transmitir datos a través del teléfono con el equipo Smart Diagnosis. Así podrá hablar directamente con nuestros técnicos especializados. El técnico graba los datos transmitidos desde la máquina y los utiliza para analizar el problema, ofreciendo un diagnóstico rápido y eficaz.

Si experimenta problemas con la lavadora, llame al 1-800-243-0000 (1-888-542-2623 en Canadá). Sólo utilice el sistema Smart Diagnosis cuando se lo pida el equipo de Smart Diagnosis. Los sonidos de transmisión que oírá son normales y suenan de forma parecida a una melodía.

Smart Diagnosis no se puede activar a menos que la lavadora se encienda pulsando el botón POWER. Si la lavadora no se puede encender, la solución de problemas deberá llevarse a cabo sin utilizar Smart Diagnosis.

USO DEL SISTEMA SMART DIAGNOSIS™

Siga las instrucciones del técnico y siga estos pasos cuando se le solicite.

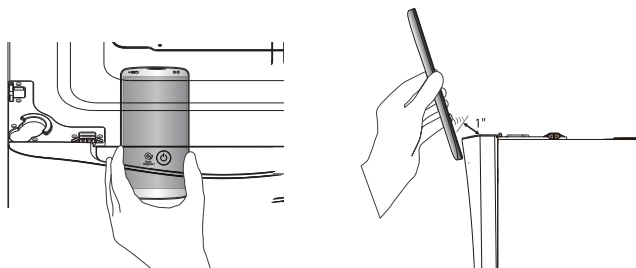

MANTENGA EL MICRÓFONO DEL TELÉFONO SOBRE EL BOTÓN DE ENCENDIDO, CUANDO EL CENTRO DE LLAMADAS SE LO SOLICITE, A NO MÁS DE 2,5 CM (PERO SIN TOCAR) LA MÁQUINA.

NOTA: NO PULSE NINGÚN OTRO BOTÓN NI GIRE EL MANDO DEL SELECTOR DE CICLO.

MANTENGA PRESIONADO EL BOTÓN WARM WATER A LA VEZ QUE MANTIENE SU TELÉFONO SOBRE EL BOTÓN POWER.

ESPERE A ESCUCHAR tres pitidos. Tras escuchar los tres pitidos, suelte el botón de WASH TEMP. Mantenga el teléfono en su sitio hasta que haya terminado la transmisión de tonos. Esto tarda unos 6 segundos y en la pantalla aparecerá el recuento de tiempo. Una vez finalizada la cuenta atrás y cuando los tonos se hayan detenido, reanude su conversación con el técnico que le podrá ayudar a utilizar la información transmitida para el análisis.

“SmartDiagnosis (Diagnostico Inteligente) es una función de resolución de problemas diseñada para asistir, no reemplazar, al método tradicional de resolución de problemas a través de llamadas de servicio técnico. La efectividad de esta función depende de diversos factores, entre los cuales se incluyen, la recepción del teléfono móvil utilizado para la transmisión, cualquier ruido externo que pueda presentarse durante la transmisión, y la acústica de la habitación donde está ubicada la lavadora. Por lo tanto, LG no garantiza que SmartDiagnosis resuelva con precisión cualquier cuestión dada.”

SOLUCIÓN DE PROBLEMAS

FAQ: PREGUNTAS FRECUENTES

P: ¿El pedestal lavador y la lavadora de carga frontal pueden funcionar al mismo tiempo?

R: Sí. El pedestal lavador está diseñado para funcionar simultáneamente debajo de lavadoras de carga frontal fabricadas por LG después de 2009. No está diseñado para funcionar debajo de lavadoras de carga superior LG, secadoras LG, aparatos que no sean fabricados por LG ni como unidad independiente. Para obtener más información sobre la compatibilidad, visite el sitio web de LG en www.lg.com/us/twinwash.

P: ¿Cuánta ropa puede cargarse en el pedestal lavador?

R: La cuba está diseñada para una carga máxima de 4 lb. (Una toalla de baño gruesa pesa aproximadamente una libra cuando está seca).

No sobrecargue la cuba de la lavadora. La ropa debe quedar floja en la cuba y la tapa debe poder cerrarse fácilmente.

P: ¿Cuánto detergente, suavizante o blanqueador debe usarse por carga?

R: ¿Cómo y cuándo se agrega a la máquina?

Detergente:

- El pedestal lavador necesita muy poco detergente. La mayoría de las cargas normales solo necesitan 1 cucharadita (5 g) de detergente de alta eficiencia (HE). Use un máximo de 2 cucharaditas (10 g) de detergente de alta eficiencia. No use el recipiente lleno de detergente.
- Vierta el detergente en el dispositivo medidor/dispensador provisto con la máquina. Coloque el dispensador en la cuba con la ropa antes de comenzar el ciclo.
- Si no tuviera el dispensador, coloque 1–2 cucharaditas (5–10 g) de detergente directamente en la cuba.
- Para obtener más información, consulte **Uso de detergente y blanqueador**.

Suavizante:

- Use $\frac{1}{4}$ de la cantidad recomendada por el fabricante para una carga normal. Use el dispensador provisto con la máquina. Para obtener las instrucciones, consulte **Uso de suavizante**.

Blanqueador:

- No use blanqueador líquido o en polvo en el pedestal lavador. Use el dispensador de blanqueador de la lavadora de carga frontal para blanquear con seguridad y eficiencia las prendas.

P: ¿Puedo abrir el cajón cuando el ciclo está funcionando?

R: No. El cajón se bloquea por seguridad durante el funcionamiento. Pause el ciclo para abrir el cajón.

P: ¿Cómo hago si quiero agregar una prenda después de que haya comenzado el ciclo?

R: Presione el botón Start/Pause para pausar el ciclo. Después de que se desbloquee el cajón, agregue la prenda y presione Start/Pause para reiniciar el ciclo. El desempeño del lavado puede verse afectado si la prenda se añade después del primer enjuague.

P: ¿Cómo seco la cuba después de que termine el ciclo?

R: ¿Cómo mantengo la cuba sin hongos ni olores?

R: Para lograr un cuidado óptimo, seque la tapa y la cuba con un paño o una toalla suaves después del uso. Deje el cajón y la tapa abiertos para una máxima circulación de aire después del uso. Ejecute el ciclo Tub Clean una vez al mes o con mayor frecuencia si fuera necesario. Aparece TCL cada 30 ciclos como recordatorio.

SONIDOS NORMALES QUE PODRÁ ESCUCHAR

Se pueden escuchar los siguientes sonidos mientras la lavadora está en funcionamiento. Son normales.

CHASQUIDOS:

Sonido cuando cierra y bloquea o desbloquea la puerta.

SONIDO DE SPRAY O SILBIDO:

El agua se está rociando o circulando en el tambor

ZUMBIDO O SONIDO DE BORBOTONES:

La bomba de desagüe vacía el agua de la lavadora tras el ciclo.

SONIDO DE CHAPOTEO:

El líquido en la goma alrededor del tambor ayuda a que éste gire suavemente.

SONIDO DE AGUA ENTRANDO EN LA LAVADORA DURANTE EL FUNCIONAMIENTO

- La lavadora se adapta al tipo y tamaño de la carga añadiendo más agua al ciclo según sea necesario.
- La carga puede estar desequilibrada. Si la lavadora detecta que la carga está desequilibrada, detiene el ciclo y reorganiza la carga para equilibrarla.
- La lavadora está diluyendo los aditivos para añadirlos a la carga de lavado.

ANTES DE LLAMAR AL SERVICIO TÉCNICO

Su lavadora está equipada con un sistema automático de control de errores que detecta y diagnostica los problemas rápidamente. Si su lavadora no funciona correctamente o no funciona en absoluto, realice las siguientes comprobaciones antes de llamar al servicio técnico:

Problema	Causa posible	Soluciones
Sonido de traqueteo y ruido metálico	Objetos tales como llaves, monedas, o alfileres pueden estar en la cuba	Detenga la lavadora y compruebe si hay objetos extraños en la cuba. Llame al servicio técnico si el ruido continúa tras reiniciar el funcionamiento de lavadora.
Sonido de golpes	Las cargas pesadas pueden provocar este ruido. La carga está desequilibrada.	Esto es normal. Si el ruido continúa probablemente la lavadora esté desnivelada. Detenga la lavadora y redistribuya la carga de lavado. Detenga el ciclo, abra la puerta y redistribuya la carga.
Ruido de vibración	No se retiraron materiales de embalaje. Carga de lavado distribuida de manera desigual en el tambor. Las patas de nivelación no están firmemente apoyadas. El suelo no es lo suficientemente rígido.	Consulte la sección Desembalaje y eliminación del Material de envío, en la sección de requisitos de instalación. Detenga el ciclo, abra la puerta y redistribuya la carga. Consulte la sección Nivelado de la lavadora del Manual de Instalación. Asegúrese de que el suelo es sólido y no se flexiona. Consulte la sección Suelos en los Requisitos de Instalación.
Fugas de agua	La conexión de la manguera de entrada de agua al grifo o lavadora está suelta. Los tubos de drenaje están obstruidos. La manguera de drenaje ha sufrido una fuga o no se ha introducido suficientemente. Una prenda de gran tamaño, como una almohada o una manta sobrepasa la parte superior del tambor.	Revise las mangueras por si hubiese fugas, grietas y rajas. Compruebe y apriete las conexiones de las mangueras. La lavadora bombea agua muy rápidamente. Compruebe la seguridad del tubo de drenaje durante el drenaje del agua. Si el agua sale del desagüe, compruebe que la manguera de desagüe está correctamente instalada y las obstrucciones en el desagüe. Póngase en contacto con un fontanero. Fije la manguera de desagüe a la manguera de entrada de agua o al tubo independiente para impedir que se salga durante el desagüe. Para tuberías de drenaje más pequeñas, inserte la manguera de drenaje en la tubería hasta la brida de la manguera de drenaje. Para tuberías de drenaje de mayor tamaño, inserte la manguera de desagüe en la tubería 1-2 pulg.más allá de la brida. Use el ciclo PRENDAS VOLUMINOSAS/ROPA DE CAMA para prendas grandes o voluminosas. No lave nunca más de la mitad de una carga con objetos flotantes como por ejemplo almohadas. Detenga la lavadora y revise la carga. Verifique que la carga no alcanza el borde superior del tambor.

ANTES DE LLAMAR AL SERVICIO TÉCNICO (continuación)

Problema	Causa posible	Soluciones
Ropa arrugada.	El tiempo de lavado es más largo de lo normal. La lavadora está sobrecargada. Las mangueras de entrada de agua caliente y fría están invertidas.	Vaciar la lavadora una vez finalizado el ciclo de lavado. Se puede cargar la lavadora completamente, pero el tambor no puede quedar colmado de prendas. La puerta de la lavadora deberá cerrar con facilidad. El aclarado con agua caliente puede provocar arrugas en las prendas. Compruebe las conexiones de la manguera de entrada.
Excesiva espuma.	Exceso de detergente.	Los detergentes de alta eficiencia están formulados específicamente para lavadoras de alta eficiencia y contienen agentes de reductores de espuma. Utilice solo detergente de Alta Eficiencia (HE: High-Efficiency). Use la cantidad correcta de detergente tal como se indica en el envase.
Coloración	El blanqueador o suavizante se dispensan antes de tiempo. El blanqueador o suavizante se añaden directamente a la carga de lavado en el tambor. El tiempo de lavado es más largo de lo normal. La ropa no se ha seleccionado correctamente.	Se ha sobrepasado el nivel máximo de llenado del compartimento provocando el dispensado inmediato del blanqueador o suavizante. NO sobrepase nunca la cantidad de blanqueador -máximo una taza. Si cierra el cajón con fuerza el suavizante puede dispensarse inmediatamente. Utilice los dispensadores para asegurar que los productos de lavado se dispensan correctamente en el momento adecuado del ciclo. Retire siempre la ropa de la lavadora lo antes posible una vez finalizado el ciclo de lavado. Separe las prendas de color oscuro de las claras o blancas para evitar la transferencia de colores. Nunca lave artículos muy sucios con prendas con poca suciedad.
La lavadora no se CIENDE.	El cable de alimentación eléctrica no se ha conectado correctamente. Se han fundido los fusibles, ha saltado el automático o se ha producido un corte de suministro eléctrico.	Asegúrese de que el enchufe está correctamente conectado a una toma de 3 clavijas con conexión a tierra, 120-VCA, 60-Hz. Restablezca el disyuntor o cambie los fusibles. No incremente la capacidad de los fusibles. Si el problema es la sobrecarga del circuito, solicite la asistencia de un electricista cualificado.
	NOTA: Si la lavadora se detiene debido a un corte de corriente, reanudará el ciclo en el que se detuvo cuando se restablezca la alimentación.	
El tiempo de lavado es más largo de lo normal.	La lavadora ajusta automáticamente el tiempo de lavado en función de la carga de lavado, el tipo de agua, su presión y otras condiciones de funcionamiento.	Esto es normal. La lavadora ajusta automáticamente el tiempo de lavado para asegurar resultados óptimos en el ciclo seleccionado. El tiempo restante que muestra la pantalla es aproximado. El tiempo real puede variar.
Olor a humedad o moho.	Detergente incorrecto o excesivo. El interior del tambor no se limpia adecuadamente.	Utilice solo detergente de Alta Eficiencia (HE: High-Efficiency) de acuerdo con las instrucciones del fabricante. Ejecute el ciclo de limpieza del tambor con regularidad
Fugas de agua.	Espuma excesiva.	El tipo y la cantidad de detergente utilizado pueden provocar que el exceso de espuma produzca fugas. El detergente de alta eficiencia es el único recomendado. Asegúrese de que detergente y aditivos se introduzcan en los compartimentos correctos. Utilice normalmente entre 1/4 a 1/2 de la cantidad máxima recomendada por el fabricante del detergente. Reduzca la cantidad de detergente si la carga es pequeña, poco sucia, o si el agua es muy blanda. No utilice una cantidad superior a la máxima recomendada por el fabricante del detergente.



ANTES DE LLAMAR AL SERVICIO TÉCNICO (continuación)

Problema	Causa posible	Soluciones
La lavadora no arranca	<p>El panel de control se ha apagado debido a su inactividad.</p> <p>La lavadora está desconectada.</p> <p>Se ha cortado el suministro de agua</p> <p>Los controles no están ajustados correctamente.</p> <p>La puerta está abierta.</p> <p>El disyuntor/fusible se ha disparado/fundido.</p> <p>El control necesita ser reajustado.</p> <p>No se ha pulsado INICIO/PAUSA tras seleccionar el ciclo.</p> <p>Nivel extremadamente bajo de presión de agua.</p> <p>La lavadora está demasiado fría.</p> <p>La lavadora está calentando el agua o haciendo vapor.</p>	<p>Esto es normal. Pulse el botón POWER para encender la lavadora.</p> <p>Asegúrese de que el cable está correctamente conectado a una toma de corriente.</p> <p>Abra completamente los grifos de agua fría y caliente.</p> <p>Asegúrese de que el ciclo está correctamente configurado, cierre la puerta y pulse el botón INICIO/PAUSA.</p> <p>La lavadora no funciona con la puerta abierta. Compruebe que no queda ningún objeto atrapado que impida el cierre de la puerta.</p> <p>Compruebe los disyuntores / fusibles de la casa. Cambie los fusibles o restablezca la corriente. Conectar la lavadora a un circuito independiente. La lavadora reanudará el ciclo donde se detuvo una vez restablecida la corriente.</p> <p>Pulse el botón POWER, vuelva a seleccionar el ciclo deseado y presione el botón INICIO/PAUSA.</p> <p>Pulse el botón POWER, vuelva a seleccionar el ciclo deseado y presione el botón INICIO/PAUSA. La lavadora se apagará si no se pulsa el botón INICIO/PAUSA transcurridos 4 minutos.</p> <p>Verifique en otro grifo de la casa que la presión del agua es adecuada.</p> <p>Si la lavadora ha estado expuesta a temperaturas bajo cero durante un período prolongado de tiempo, deje que se caliente antes de presionar el botón POWER. De lo contrario, la pantalla no se iluminará.</p> <p>El tambor de la lavadora puede dejar de funcionar temporalmente durante ciertos ciclos, mientras el agua se calienta hasta llegar a la temperatura establecida.</p>
No entra bien el agua en la lavadora	<p>Filtro obstruido.</p> <p>Las mangueras de entrada pueden estar dobladas.</p> <p>Eficiencia energética.</p> <p>Suministro de agua caliente.</p> <p>La puerta de la lavadora está abierta.</p> <p>Las mangueras de entrada de agua caliente y fría están invertidas.</p> <p>El nivel de agua es demasiado bajo.</p>	<p>Compruebe que los filtros de entrada de las válvulas de llenado no están obstruidos.</p> <p>Consulte las instrucciones de limpieza del filtro.</p> <p>Esta es una lavadora de Alta Eficiencia (HE: High-Efficiency). Por ello, los ajustes de nivel de agua para esta lavadora pueden ser diferentes a los de las lavadoras convencionales.</p> <p>Asegúrese de que los grifos de agua fría y caliente están abiertos.</p> <p>La lavadora no funciona con la puerta abierta. Compruebe que no quede ningún objeto atrapado que impida el cierre de la puerta.</p> <p>Compruebe las conexiones de la manguera de entrada. Asegúrese de que el suministro de agua caliente está conectado a la válvula de entrada de agua caliente, y el suministro de agua fría está conectado a la válvula de entrada de agua fría.</p> <p>Esta es una lavadora de Alta Eficiencia. El agua no cubrirá la ropa. El nivel de llenado se ha optimizado para que el movimiento de la lavadora permita obtener los mejores resultados de lavado.</p>

ANTES DE LLAMAR AL SERVICIO TÉCNICO (continuación)

Problema	Causa posible	Soluciones
La lavadora no desagua	Manguera de desagüe retorcida. Desagüe situado a 96 pulg. por encima del piso	Compruebe que la manguera de desagüe no está retorcida. Compruebe que la manguera de desagüe no supera los 8 pies desde la parte inferior de la lavadora ni está más de 5 pies separada de la lavadora.
Escasa eliminación de manchas	Prendas muy manchadas. Tratar las manchas previamente.	El pedestal lavador está diseñado para cuidar de sus prendas menos manchadas de manera suave y efectiva. Las manchas más difíciles y densas pueden requerir de la potencia de lavado adicional de las funciones Soak o Stain Care de la lavadora de carga frontal. Los prendas lavadas con anterioridad pueden tener manchas que no se hayan ido en el lavado. Estas manchas pueden ser difíciles de quitar y requerir un lavado a mano o un pretratamiento para ayudar a su eliminación.
El agua se filtra en cada carga	Las mangueras no están instaladas correctamente. La manguera de desagüe de la secadora híbrida no está instalada correctamente.	Compruebe que las conexiones de la manguera de llenado y desagüe están bien apretadas y son seguras. No inserte una manguera de secadora híbrida en un conector en Y a más de 3/4 pulg. Consulte la sección Conexión de la manguera de desagüe. Verifique que las abrazaderas y los precintos estén bien ajustados. Instale las abrazaderas y los precintos si no lo ha hecho aún. Consulte la sección Conexión de la manguera de desagüe.

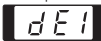
CÓDIGOS DE ERROR

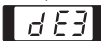
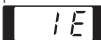
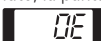
Problema	Causas posibles	Soluciones
En la pantalla se observa:  	El cajón no está bien cerrado.	Cierre el cajón y presione el botón de Inicio/Pausa para iniciar el ciclo. Si el cajón está cerrado y aparece el mensaje de error de bloqueo del cajón, llame al servicio técnico.
En la pantalla se observa: 	La tapa no está bien cerrada.	Abra el cajón y asegúrese de que la zona de la cerradura no tenga ropa u otras obstrucciones. Cierre la tapa, cierre el cajón y presione el botón de Inicio/Pausa para iniciar el ciclo. Si la tapa está cerrada y aparece el mensaje de error de la tapa, llame al servicio técnico.
El agua entra en la lavadora muy lentamente o no lo hace en absoluto; la pantalla muestra: 	Los grifos de suministro de agua no están completamente abiertos. Las mangueras de suministro de agua están retorcidas, perforadas o aplastadas. Los filtros de entrada de agua están obstruidos. La presión del agua en el grifo o en la vivienda es demasiado baja. El suministro de agua está limitado por mangueras con fuga.	Compruebe que los grifos del agua están totalmente abiertos. Compruebe que las mangueras no están retorcidas ni aplastadas. Mueva cuidadosamente la lavadora para proceder a su limpieza o mantenimiento. Limpie los filtros de entrada. Consulte Mantenimiento en la sección de Cuidado y Limpieza. Compruebe en otro grifo que la presión del agua es adecuada y que el flujo no está limitado. Desconecte la manguera de entrada de la lavadora y deje correr unos cuantos litros de agua a través de la manguera para limpiar las tuberías de suministro de agua. Si el flujo es demasiado bajo, póngase en contacto con un fontanero. Las mangueras diseñadas para limitar el flujo del agua pueden provocar que la lavadora no se llene. No se recomienda el uso de mangueras limitadoras de flujo.
La lavadora no se enciende.	El cable de alimentación eléctrica no se ha conectado correctamente. Se han fundido los fusibles, ha saltado el automático o se ha producido un corte de suministro eléctrico.	Compruebe que el enchufe está correctamente conectado a una toma de 3 clavijas 120-VAC, 60-Hz. salida. Restablezca el disyuntor o cambie los fusibles. No incremente la capacidad de los fusibles. Si el problema es la sobrecarga del circuito, solicite la asistencia de un electricista calificado.
El agua entra en la lavadora muy lentamente o no lo hace en absoluto; la pantalla muestra: 	La manguera de desagüe está retorcida, aplastada u obstruida. La longitud total de la manguera de drenaje debe ser inferior a 96 pulg. desde la parte inferior de la lavadora.	Verifique que la manguera de drenaje no está obstruida, retorcida, et., ni atrapada detrás o debajo de la lavadora. Ajuste o reparación del drenaje. La altura máxima de la manguera de drenaje es 96 pulg. (8 pies.)
La lavadora produce un sonido repetitivo antes del enjuague final.	Esto no es un error. Es una alerta para permitir añadir suavizante líquido antes del enjuague final.	Consulte la sección Uso de suavizante (página 16) para obtener instrucciones sobre cómo agregar suavizante líquido para prendas a la carga. Para activar o desactivar el alerta del suavizante, mantenga presionados los botones Warm Water y Extra Rinse al mismo tiempo durante tres segundos.

CÓDIGOS DE ERROR (CONTINUACIÓN)

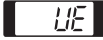
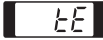
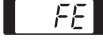
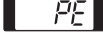
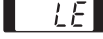
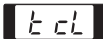
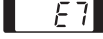
Problema	Causas posibles	Soluciones
La pantalla muestra: 	Si la operación de equilibrado UE (ver más arriba) no se realiza con éxito, se mostrará este error. La carga es demasiado pequeña. Prendas pesadas se mezclan con otras ligeras. La carga está desequilibrada.	El reequilibrado automático de la carga no ha tenido éxito. Detenga el ciclo para reequilibrar la carga manualmente. Las cargas pequeñas necesitan prendas adicionales para equilibrar la carga de la lavadora. La carga puede contener tanto prendas pesadas como ligeras. Trate de lavar prendas de peso similar para que la lavadora distribuya uniformemente el peso. Redistribuya manualmente la carga si los artículos se han enredado e impiden la distribución automática.
La pantalla muestra: 	Error de control.	Desenchufe el cable de alimentación y comuníquese con el servicio técnico de LG más cercano.
La pantalla muestra: 	El nivel del agua es demasiado alto debido a una válvula de agua defectuosa.	Cierre el grifo de agua, desconecte el enchufe de la toma de corriente y póngase en contacto con el servicio técnico.
La pantalla muestra: 	El sensor de nivel de agua no funciona correctamente.	Cierre el grifo de agua, desconecte el enchufe de la toma de corriente y póngase en contacto con el servicio técnico.
La pantalla muestra: 	Se ha producido un error en el motor.	Deje la lavadora en espera durante 30 minutos y a continuación reinicie el ciclo. Si el código de error LE persiste, póngase en contacto con el servicio técnico.
La pantalla muestra: 	Para limpiar el tambor, seleccione el ciclo de limpieza del tambor.	Vacíe el tambor e introduzca lejía en el cajón dispensador y seleccione el ciclo TUB CLEAN (limpieza de tambor). Si no desea hacer la limpieza del tambor, gire el selector de ciclos o pulse los botones opcionales para seleccionar el ciclo deseado. En este caso, verá el mensaje nuevamente durante los siguientes lavados y desaparecerá hasta que sea tiempo de limpiar el tambor nuevamente.
La pantalla muestra: 	El pedestal lavador está funcionando sin la lavadora de tamaño completo. El interruptor de apilado no está funcionando adecuadamente.	El pedestal lavador no funciona como una unidad autónoma. Debe colocarse debajo de un aparato LG de tamaño completo. El interruptor de apilado no funcionará adecuadamente si la unidad está colocada debajo de un aparato que no es de LG o de un aparato LG fabricado antes del año 2009.

GARANTÍA LIMITADA PARA LAVADORA LG (EE.UU.)

COBERTURA DE LA GARANTÍA:

LG Electronics U.S.A., Inc. ("LG") garantiza su lavadora LG ("producto") contra cualquier defecto en materiales o mano de obra bajo un uso doméstico normal, durante el periodo de garantía indicado más adelante, y LG podrá reparar o sustituir el producto, bajo su exclusivo criterio. Esta garantía limitada tiene validez sólo para el comprador minorista original del producto, no puede cederse o transferirse a cualquier comprador o usuario posterior, y se aplica sólo cuando el producto se haya adquirido a través de un distribuidor LG autorizado y se haya utilizado en Estado Unidos ("EE.UU."), incluidos los Territorios de EE.UU.

Nota: Los productos de sustitución o piezas de reparación pueden ser nuevos o remanufacturados en fábrica y tendrán garantía para el tiempo restante del periodo original de garantía o noventa (90) días, el que sea más largo. Guarde la factura o el justificante de compra como prueba de la fecha de compra para la garantía (se le podría pedir que envíe una copia a LG o un representante autorizado).

PERIODO DE GARANTÍA:

Periodo	Un (1) año a partir de la fecha de compra original:	Diez (10) años a partir de la fecha de compra original:	Toda la vida útil desde la fecha de compra original:
Alcance de la garantía	Cualquier pieza interna/funcional	Motor del tambor (estator, rotor y sensor Hall)	Tambor de acero inoxidable
Observación	LG suministrará las piezas y la mano de obra para la reparación o sustituirá las piezas defectuosas.	Sólo piezas. El cliente será responsable de la mano de obra o la reparación a domicilio para la sustitución de las piezas defectuosas.	

CÓMO SE PRESTA EL SERVICIO: Servicio a domicilio

El servicio a domicilio se prestará, según esté disponible, durante el período de garantía según la disponibilidad del personal de servicio técnico en EE.UU. Para recibir servicio a domicilio el producto deberá estar accesible y sin obstrucciones para el personal de servicio. Si no se puede prestar el servicio de reparación a domicilio, puede ser necesario retirar, reparar y devolver el producto. Si no está disponible el servicio a domicilio, LG podrá decidir si facilitará transporte para el producto a y desde cualquier servicio técnico de LG, según su elección.

ESTA GARANTÍA LIMITADA NO CUBRE:

- Desplazamientos de servicio para el envío, recogida o instalación del producto o para dar instrucciones sobre la utilización del producto.
- Sustitución de los fusibles de la vivienda o puesta en funcionamiento de los disyuntores, corrección de la instalación eléctrica de la casa o fontanería, o corrección de la instalación del producto.
- Daños o fallos causados por tubos de agua con fugas o roturas, tubos de agua congelados, tubos de desagüe atascados, suministro de agua inadecuado o con interrupciones o suministro de aire inadecuado.
- Daños al producto causados por accidentes, pestes e insectos, rayos, viento, fuego, inundaciones o causas de fuerza mayor.
- Daños o fallos resultantes de un uso inadecuado, abusos, instalación, reparaciones o mantenimiento incorrectos. Las reparaciones incorrectas incluyen la utilización de piezas no aprobadas o especificadas por LG.
- Daños o fallos causados por la modificación u alteración no autorizada del producto.

- Daños o fallos causados por la corriente eléctrica, tensión o códigos de fontanería incorrectos.
- Daños cosméticos, incluidos arañazos, abolladuras u otros daños en el acabado del producto, a menos que los daños sean resultado de defectos de materiales o mano de obra y se informe a LG en un plazo de siete (7) días calendario a partir de la fecha de entrega.
- Daños o falta de elementos en cualquier producto de exposición, caja abierta, de descuento o reacondicionado.
- Productos en los que se haya borrado, desdibujado o cambiado el número de serie original de fábrica.
- Reparaciones cuando se esté dando al producto una utilización diferente del uso doméstico normal (por ejemplo, alquiler, uso comercial, oficinas e instalaciones recreativas) o contraría a las instrucciones del manual del propietario del producto.
- La retirada y nueva instalación del producto si se ha instalado en una ubicación inaccesible.

ESTA GARANTÍA EXCLUYE CUALQUIER OTRA GARANTÍA, EXPRESA O IMPLÍCITA, INCLUYENDO Y SIN LIMITACIÓN A CUALQUIER GARANTÍA DE COMERCIABILIDAD O ADECUACIÓN A UN FIN PARTICULAR. EN EL GRADO EN QUE CUALQUIER GARANTÍA IMPLÍCITA SEA REQUERIDA POR LEY, ESTA GARANTÍA SE LIMITARÁ EN SU DURACIÓN AL PERIODO INDICADO ANTERIORMENTE. LA REPARACIÓN O SUSTITUCIÓN BAJO ESTA GARANTÍA ES LA ÚNICA SOLUCIÓN PARA EL CLIENTE. NI EL FABRICANTE, NI SUS DISTRIBUIDORES EN EE.UU. SERÁN RESPONSABLES DE CUALQUIER DAÑO INCIDENTAL, CONSECUENCIAL, INDIRECTO, ESPECIAL O PUNITIVO DE CUALQUIER TIPO, INCLUIDAS SIN LIMITACIÓN, PÉRDIDAS DE INGRESOS O BENEFICIOS, O CUALQUIER OTRO DAÑO BASADOS EN CONTRATOS, RESPONSABILIDADES EXTRA CONTRACTUALES O DE OTRO TIPO.

INCLUYENDO Y SIN LIMITACIÓN A, PERMITEN LA EXCLUSIÓN O LIMITACIÓN DE LOS DAÑOS INCIDENTALES O CONSECUENCIALES O LAS LIMITACIONES SOBRE LA DURACIÓN DE UNA GARANTÍA IMPLÍCITA, POR LO QUE PUEDEN NO SER APLICABLES A SU CASO LAS CITADAS EXCLUSIONES. ESTA GARANTÍA LE CONFIERE DERECHOS LEGALES ESPECÍFICOS Y TAMBIÉN PUEDE TENER OTROS DERECHOS QUE VARIÁN DE UNOS ESTADOS A OTROS.

CÓMO OBTENER SERVICIO DE GARANTÍA E INFORMACIÓN ADICIONAL:

Llame al número 1-800-243-0000 o visite nuestro sitio web en www.lg.com. Si desea ponerse en contacto por correo: Centro de información al cliente LG (ATT: CIC)
201 James Record Road, Huntsville, AL 35824



LG Customer Information Center

1-800-243-0000 USA
1-888-542-2623 CANADA

Register your product Online!

www.lg.com