



# MULTI F

# MULTI F MAX

## OUTDOOR UNIT INSTALLATION MANUAL

**Multi-Zone Heat Pump Systems**  
**1.5 to 5 Tons**



Dual and Tri-Zone  
Multi F



Quad-Zone  
Multi F



Eight-Zone  
Multi F MAX

## **PROPRIETARY DATA NOTICE**

This document, as well as all reports, illustrations, data, information, and other materials are the property of LG Electronics U.S.A., Inc., and are disclosed by LG Electronics U.S.A., Inc. only in confidence.

**Do not throw away, destroy, or lose this manual.  
Please read carefully and store in a safe place for future reference.  
Content familiarity required for proper installation.**

The instructions included in this manual must be followed to prevent product malfunction, property damage, injury, or death to the user or other people. Incorrect operation due to ignoring any instructions will cause harm or damage. The level of seriousness is classified by the symbols described by the summary list of safety precautions on page 4.





**For more materials such as submittals, catalogs, engineering, installation, owner's, and service manuals, visit [www.lghvac.com](http://www.lghvac.com).**

For continual product development, LG Electronics U.S.A., Inc. reserves the right to change specifications without notice.

© LG Electronics U.S.A., Inc.

The instructions below must be followed to prevent product malfunction, property damage, injury or death to the user or other people. Incorrect operation due to ignoring any instructions will cause harm or damage. The level of seriousness is classified by the symbols described below.

**TABLE OF SYMBOLS**

 <b>DANGER</b>	<i>This symbol indicates an imminently hazardous situation which, if not avoided, will result in death or serious injury.</i>
 <b>WARNING</b>	<i>This symbol indicates a potentially hazardous situation which, if not avoided, could result in death or serious injury.</i>
 <b>CAUTION</b>	<i>This symbol indicates a potentially hazardous situation which, if not avoided, may result in minor or moderate injury.</i>
<b>Note</b>	<i>This symbol indicates situations that may result in equipment or property damage accidents only.</i>
	<i>This symbol indicates an action should not be completed.</i>

**Installation**

 **DANGER**

 **Do not store or use flammable gas or combustibles near the unit.**  
*There is risk of fire, explosion, and physical injury or death.*

 **Do not supply power to the unit until all wiring and piping are completed or reconnected and checked.**  
*There is risk of physical injury or death due to electric shock.*

 **WARNING**

 **Do not install, remove, or re-install the unit by yourself (end user). Ask the dealer or a trained technician to install the unit.**  
*Improper installation by the user may result in fire, explosion, electric shock, physical injury or death.*

**For replacement of an installed unit, always contact an LG trained service provider.**  
*There is risk of fire, electric shock, explosion, and physical injury or death.*

**Wear protective gloves when handling equipment. Sharp edges may cause personal injury.**

 **Do not change the settings of the protection devices.**  
*If the protection devices have been bypassed or is forced to operate improperly, or parts other than those specified by LG are used, there is risk of fire, electric shock, explosion, and physical injury or death.*

**Replace all control box and panel covers.**  
*If cover panels are not installed securely, dust, water and animals may enter the outdoor unit, causing fire, electric shock, and physical injury or death.*

**Always check for system refrigerant leaks after the unit has been installed or serviced.**  
*Exposure to high concentration levels of refrigerant gas may lead to illness or death.*

**Periodically check that the outdoor frame is not damaged.**  
*There is a risk of explosion, physical injury, or death.*

**If the air conditioner is installed in a small space, take measures to prevent the refrigerant concentration from exceeding safety limits in the event of a refrigerant leak.**  
*Consult the latest edition of ASHRAE (American Society of Heating, Refrigerating, and Air Conditioning Engineers) Standard 15. If the refrigerant leaks and safety limits are exceeded, it could result in personal injuries or death from oxygen depletion.*

**The branch distribution (BD) unit must be installed indoors;**  
 **do not install the BD unit in a highly humid environment.**  
*There is risk of physical injury or death due to electric shock.*

**Dispose the packing materials safely.**  
• *Packing materials, such as nails and other metal or wooden parts, may cause puncture wounds or other injuries.*  
• *Tear apart and throw away plastic packaging bags so that children may not play with them and risk suffocation and death.*

**Install the unit considering the potential for strong winds or earthquakes.**  
*Improper installation may cause the unit to fall over, resulting in physical injury or death.*

**Install the unit in a safe location where nobody can step, fall onto it, or place objects on it.**  **Do not install the unit on a defective stand.**  
*It may result in an accident that causes physical injury or death.*

## Installation, continued

### ⚠ WARNING

**Properly insulate all cold surfaces to prevent “sweating.”**

*Cold surfaces such as uninsulated piping can generate condensate that could drip, causing a slippery surface that creates a risk of slipping, falling, and personal injury.*

### ⚠ CAUTION

**Be very careful when transporting the product. There is a risk of the product falling and causing physical injury.**

- Use appropriate moving equipment to transport each frame; ensure the equipment is capable of supporting the weights listed.
- Some products use polypropylene bands for packaging. Ⓣ Do not use polypropylene bands to lift the unit.
- Support the outdoor unit a minimum of four points to avoid slippage from rigging apparatus.

### Note

LG Electronics U.S.A., Inc., is not responsible for any piping calculations, refrigerant leaks, degradation of performance, or any other potential problems or damages as a result of interconnecting piping, their joint connections, isolation valves, introduced debris inside the piping system, or other problems caused by the interconnecting piping system.

Ⓣ Do not install the product where it is exposed directly to ocean winds.

*Sea salt in the air may cause the product to corrode. Corrosion, particularly on the condenser and evaporator fins, could cause product malfunction or inefficient operation.*

**When installing the outdoor unit in a low-lying area, or a location that is not level, use a raised concrete pad or concrete blocks to provide a solid, level foundation.**

*This prevents water damage and abnormal vibration.*

**Properly insulate all cold surfaces to prevent “sweating.”**

*Cold surfaces such as uninsulated piping can generate condensate that may drip and cause water damage to walls.*

**Always check for system refrigerant leaks after the unit has been installed or serviced.**

*Low refrigerant levels may cause product failure.*

**The branch distribution (BD) unit must be installed indoors;**

Ⓣ Do not install the BD box in a highly humid environment. *There is risk of product failure and property damage.*

Ⓣ Do not make refrigerant substitutions. Use R410A only.

*If a different refrigerant is used, or air mixes with original refrigerant, the unit will malfunction and be damaged.*

Ⓣ Do not store or use flammable gas / combustibles near the unit.

*There is a risk of product failure.*

Ⓣ Do not use the product for mission critical or special purpose applications such as preserving foods, works of art, or other precision air conditioning applications. The equipment is designed to provide comfort cooling and heating.

*There is risk of property damage.*

**Keep the unit upright during installation to avoid vibration or water leakage.**

**When connecting refrigerant tubing, remember to allow for pipe expansion.**

*Improper piping may cause refrigerant leaks and system malfunction.*

Ⓣ Do not install the outdoor unit or BD unit in a noise-sensitive area.

**Take appropriate actions at the end of HVAC equipment life to recover, recycle, reclaim or destroy R410A refrigerant according to applicable U.S. Environmental Protection Agency (EPA) rules.**

**Periodically check that the outdoor frame is not damaged.**

*There is a risk of equipment damage.*

**Install the unit in a safe location where nobody can step on or fall onto it. Do not install the unit on a defective stand.**

*There is a risk of unit and property damage.*

**Install the drain hose to ensure adequate drainage.**

*There is a risk of water leakage and property damage.*

---

---

## Wiring

### ⚠ DANGER

**High voltage electricity is required to operate this system. Adhere to the NEC code and these instructions when wiring. Improper connections and inadequate grounding can cause accidental injury or death.**

**Always ground the unit following local, state, and NEC codes.**  
*There is risk of fire, electric shock, and physical injury or death.*

**Turn the power off at the nearest disconnect before servicing the equipment.**  
*Electrical shock can cause physical injury or death.*

**Properly size all circuit breakers or fuses.**  
*There is risk of fire, electric shock, explosion, physical injury or death.*

⊘ **Do not share the electrical circuit with other appliances.**  
*There is risk of fire, electric shock, and physical injury or death due to heat generation.*

⊘ **Do not use damaged or loose power wiring.** ⊘ **Do not modify or extend the outdoor unit's power wiring randomly. Ensure that the power wiring will not be pulled nor weight be placed on the power wiring during operation.**  
*There is risk of fire, electric shock, and physical injury or death.*

---

### ⚠ WARNING

**The information contained in this manual is intended for use by an industry-qualified, experienced, certified electrician familiar with the U.S. National Electric Code (NEC) who is equipped with the proper tools and test instruments. Failure to carefully read and follow all instructions in this manual can result in equipment malfunction, property damage, personal injury or death.**

**All electric work must be performed by a licensed electrician and conform to local building codes or, in the absence of local codes, with the National Electrical Code, and the instructions given in this manual.**  
*If the power source capacity is inadequate or the electric work is not performed properly, it may result in fire, electric shock, physical injury or death.*

**Refer to local, state, and federal codes, and use power wires of sufficient current capacity and rating.**  
*Wires that are too small may generate heat and cause a fire.*

**Secure all field wiring connections with appropriate wire strain relief.**  
*Improperly securing wires will create undue stress on equipment power lugs. Inadequate connections may generate heat, cause a fire and physical injury or death.*

**Ensure the system is connected to a dedicated power source that provides adequate power.**  
*If the power source capacity is inadequate or the electric work is not performed properly, it may result in fire, electric shock, physical injury or death.*

**Properly tighten all power connections.**  
*Loose wiring may overheat at connection points, causing a fire, physical injury or death.*

⊘ **Do not change the settings of the protection devices.**  
*If the protection devices have been bypassed or are forced to operate improperly, or parts other than those specified by LG are used, there is risk of fire, electric shock, explosion, and physical injury or death.*

---

## Note

⊘ **Do not supply power to the unit until all electrical wiring, controls wiring, piping, installation, and refrigerant system evacuation are completed.**  
*System may malfunction.*

## Operation

### ⚠ DANGER

- ⊘ Do not provide power to or operate the unit if it is flooded or submerged.

*There is risk of fire, electric shock, physical injury or death.*

**Use a dedicated breaker for this product.**

*There is risk of fire, electric shock, physical injury or death.*

- ⊘ Do not operate the disconnect switch with wet hands.

*There is risk of fire, electric shock, physical injury or death.*

**Periodically verify the equipment mounts have not deteriorated.**

*If the base collapses, the unit could fall and cause physical injury or death.*

**Use inert (nitrogen) gas when performing leak tests or air purges. ⊘ Do not use compressed air, oxygen, or flammable gases.**

*Using these substances may cause fire, explosion, and physical injury or death.*

**If refrigerant leaks out, ventilate the area before operating the unit.**

*If the unit is mounted in an enclosed, low-lying, or poorly ventilated area, and the system develops a refrigerant leak, it may cause a fire, electric shock, explosion, physical injury or death.*

### ⚠ WARNING

- ⊘ Do not allow water, dirt, or animals to enter the unit.

*There is risk of fire, electric shock, physical injury or death.*

- ⊘ Do not operate the unit with the panel(s) or protective cover(s) removed; keep fingers and clothing away from moving parts.

*The rotating, hot, cold, and high-voltage parts of the unit can cause physical injury or death.*

- ⊘ Do not touch the refrigerant piping during or after operation.

*It can cause burns or frostbite.*

- ⊘ Do not open the inlet during operation.

*There is risk of electric shock, physical injury or death.*

### ⚠ CAUTION

**To avoid physical injury, use caution when cleaning or servicing the air conditioner.**

### Note

**Clean up the site after servicing is finished, and check that no metal scraps, screws, or bits of wiring have been left inside or surrounding the unit.**

- ⊘ Do not use the product for mission critical or special purpose applications such as preserving foods, works of art, or other precision air conditioning applications. The equipment is designed to provide comfort cooling and heating.

*Oil, steam, sulfuric smoke, etc., can significantly reduce the performance of the unit, or damage its parts.*

- ⊘ Do not block the inlet or outlet.

*Unit may malfunction.*

- ⊘ Do not allow water, dirt, or animals to enter the unit.

*There is risk of unit failure.*

- ⊘ Do not open the inlet during operation.

*There is risk of unit failure.*

- ⊘ Do not operate the unit when the panel(s) or protective cover(s) are removed; keep fingers and clothing away from moving parts.

*Non-secured covers can result in malfunction due to dust or water in the service panel.*

**Periodically verify the equipment mounts have not deteriorated.**

*If the base collapses, the unit could fall and cause property damage or product failure.*

**Use a only soft cloth to clean the air conditioner. ⊘ Do not use wax, thinner, or strong detergents.**

*Strong cleaning products may damage the surface of the air conditioner, or may cause its appearance to deteriorate.*

---



---

Safety Instructions .....	3-6
<b>Multi F / Multi F MAX Outdoor Unit Specifications</b> .....	<b>8-10</b>
Electrical Data .....	11
R410A Refrigerant .....	12
<b>General Installation Guidelines</b> .....	<b>13-34</b>
<i>Location Selection for Outdoor Units</i> .....	13
<i>Oceanside Installation Precautions</i> .....	13
<i>Rooftop Installations</i> .....	14
<i>Planning for Snow and Ice</i> .....	14
<i>Tie-Downs and Lightning Protection</i> .....	14
<i>Allowable Clearances</i> .....	15-17
<i>Rigging and Lifting Instructions</i> .....	18
<i>Platform Instructions</i> .....	19
<i>Mounting Bolt Location</i> .....	19
<i>Location Selection for Branch Distribution Unit</i> .....	20-21
<i>Branch Distribution Unit Installation</i> .....	22-23
Piping Preparation .....	24-25
Piping Materials and Handling .....	26-34
Refrigerant Piping Connections .....	35-40
Flushing the Refrigerant Piping .....	41
Leak Test and Vacuum Procedures .....	42-44
Refrigerant Charge .....	45-47
Refrigerant Piping Insulation .....	48-52
<b>Electrical Wiring</b> .....	<b>53-70</b>
<i>General Information</i> .....	53-54
<i>Power Wiring and Communications Cable Connections</i> .....	55-59
<i>Test Run</i> .....	60
<i>DIP Switch Settings</i> .....	61-65
<i>Self Diagnosis Functions</i> .....	66-71
Caution for Refrigerant Leakage .....	72-73
Installation Checklists .....	74-79

# SPECIFICATIONS

## Multi F Outdoor Units

MULTI F  
MULTI F MAX

Table 1: Multi F Outdoor Unit Specifications.

Model Number	LMU18CHV	LMU24CHV	LMU30CHV	LMU36CHV
Cooling Capacity (Btu/h) <sup>1</sup> (Min.-Rated- Max.)	8,400-17,000-19,000	8,400-20,000-25,000	8,400-30,000-36,000	8,400-32,000-38,400
Heating Capacity (Btu/h) <sup>1</sup> (Min.-Rated- Max.)	10,248-22,000-24,000	9,240-24,000-28,800	9,240-32,000-38,400	9,240-36,000-41,600
<b>Operating Range</b>				
Cooling (°F DB)	14 <sup>7</sup> - 118	14 <sup>7</sup> - 118	14 <sup>7</sup> - 118	14 <sup>7</sup> - 118
Heating (°F WB)	-4 - 64	-4 - 64	-4 - 64	-4 - 64
<b>Compressor</b>				
Inverter Quantity	Twin Rotary x 1	Twin Rotary x 1	Twin Rotary x 1	Twin Rotary x 1
Oil Type	FVC68D	FVC68D	FVC68D	FVC68D
<b>Fan (Side Discharge)</b>				
Type	Propeller	Propeller	Propeller	Propeller
Motor Output (W) x Qty.	85.4 x 1	85.4 x 1	124.2 x 1	124.2 x 1
Motor/Drive	Brushless Digitally Controlled / Direct			
Maximum Air Volume (CFM)	1,766	1,766	2,119	2,119
<b>Unit Data</b>				
Refrigerant Type	R410A	R410A	R410A	R410A
Refrigerant Control/Location	EEV/Outdoor Unit	EEV/Outdoor Unit	EEV/Outdoor Unit	EEV/Outdoor Unit
Min. Number Indoor Units/System <sup>2</sup>	2	2	2	2
Max. Number Indoor Units/System <sup>2</sup>	2	3	4	4
Maximum Allowable Total Indoor Unit Connected Capacity (Btu/h)	24,000	33,000	40,000	48,000
Sound Pressure (Cooling / Heating) dB(A) <sup>3</sup>	49 / 52	49 / 52	52 / 55	52 / 55
Net Unit Weight (lbs.)	100	100	137	137
Shipping Weight (lbs.)	108	108	148	148
Power Wiring / Communications Cable (No. x AWG) <sup>4,5</sup>	4C x 18	4C x 18	4C x 18	4C x 18
<b>Heat Exchanger</b>				
Material and Fin Coating	Copper Tube/Aluminum Fin and GoldFin™/Hydrophilic			
Rows/Columns/Fins per inch x Qty.	(2 x 28 x 14) x 1	(2 x 28 x 14) x 1	(2 x 38 x 14) x 1	(2 x 38 x 14) x 1
<b>Piping</b>				
Liquid Line Connection (in., OD) x Qty.	1/4 x 2	1/4 x 3	1/4 x 4	1/4 x 4
Vapor Line Connection (in., OD) x Qty.	3/8 x 2	3/8 x 3	3/8 x 4	3/8 x 4
Factory Charge lbs. of R410A	3.96	3.96	6.18	6.18
<b>Piping Lengths</b>				
Maximum Total Piping (ft.) <sup>6</sup>	164.0	246.1	246.1	246.1
Maximum Outdoor Unit to Indoor Unit Piping (ft)	82.0	82.0	82.0	82.0
Piping Length (No Additional Refrigerant [ft])	49.2	73.8	98.4	98.4
Maximum Elevation between Outdoor Unit and Indoor Unit (ft.)	49.2	49.2	49.2	49.2
Maximum Elevation between Indoor Unit and Indoor Unit (ft.)	24.6	24.6	24.6	24.6

<sup>1</sup>Rated capacity applied with non-ducted indoor units, and is rated 0 ft. above sea level with 25 ft. of refrigerant line per indoor unit and a 0 ft. level difference between outdoor and indoor units. All capacities are net with a combination ratio between 95 - 105%.

Rated cooling capacity obtained with air entering the indoor unit at 80°F dry bulb (DB) and 67°F wet bulb (WB) and outdoor ambient conditions of 95°F dry bulb (DB) and 75°F wet bulb (WB).

Rated heating capacity obtained with air entering the indoor unit at 70°F dry bulb (DB) and 60°F wet bulb (WB) and outdoor ambient conditions of 47°F dry bulb (DB) and 43°F wet bulb (WB).

<sup>2</sup>At least two indoor units should be connected. For allocated capacity information, see the combination tables in the "Multi F / Multi F MAX Combination Data Manual" on www.lg-dfs.com. For performance data, see "Multi F / Multi F MAX Performance Data Manual" on www.lg-dfs.com.

<sup>3</sup>Sound pressure levels are tested in an anechoic chamber under ISO Standard 3745 and are the same in both cooling and heating mode. These values can increase due to ambient conditions during operation.

<sup>4</sup>Power wiring to the outdoor unit is field supplied, solid or stranded, and must comply with the applicable local and national codes. For detailed information, please refer to electrical characteristics on page 11.

<sup>5</sup>All power wiring / communication cable to be minimum 18 AWG from the outdoor unit to the indoor unit, stranded, shielded or unshielded (if shielded, it must be grounded to the chassis of the outdoor unit only), and must comply with applicable local and national codes. For detailed electrical information, please refer to electric characteristics on page 11.

<sup>6</sup>Piping lengths are equivalent.

<sup>7</sup>Installation of an optional Low Ambient Wind Baffle Kit will allow operation down to -4°F in cooling mode.

Table 2: Multi F MAX Outdoor Unit General Data.

Model Number	LMU480HV	LMU540HV	LMU600HV
Cooling Capacity (Btu/h) (Minimum ~ Rated ~ Maximum) <sup>1</sup>	14,400~48,000~58,000	14,400~52,500~63,200	15,600~60,000~68,000
Heating Capacity (Btu/h) (Minimum ~ Rated ~ Maximum) <sup>1</sup>	15,840~54,000~61,000	16,272~58,000~64,000	17,940~64,000~70,000
<b>Operating Range</b>			
Cooling (°F DB)	14 <sup>7</sup> - 118	14 <sup>7</sup> - 118	14 <sup>7</sup> - 118
Heating (°F WB)	-4 - 64	-4 - 64	-4 - 64
<b>Compressor</b>			
Inverter Quantity	Twin Rotary x 1	Twin Rotary x 1	Twin Rotary x 1
Oil Type	FVC68D	FVC68D	FVC68D
<b>Fan (Side Discharge)</b>			
Type	Propeller	Propeller	Propeller
Motor Output (W) x Qty.	124.2 x 2	124.2 x 2	124.2 x 2
Motor/Drive	Brushless Digitally Controlled/Direct		
Maximum Air Volume (CFM)	2,119 x 2	2,119 x 2	2,119 x 2
<b>Unit Data</b>			
Refrigerant Type	R410A	R410A	R410A
Refrigerant Control/Location	EEV / Outdoor Unit, Branch Distribution Unit		
Min. Number Indoor Units/System <sup>2</sup>	2	2	2
Max. Number Indoor Units/System <sup>2</sup>	8	8	8
Maximum Allowable Total Indoor Unit Connected Capacity (Btu/h)	65,000	73,000	81,000
Sound Pressure ±3 dB(A) <sup>3</sup> (Cooling / Heating)	54 / 56	54 / 56	56 / 58
Net Unit Weight (lbs.)	214	214	223
Shipping Weight (lbs.)	236	236	249
Power/Communications Wiring Between ODU and BD Unit (No. X AWG) <sup>4,5</sup>	4C X 16	4C X 16	4C x 16
<b>Heat Exchanger</b>			
Material and Fin Coating	Copper Tube / Aluminum Fin and GoldFin™/Hydrophilic		
Rows/Columns/Fins per inch x Qty.	(2 x 32 x 14) x 2	(2 x 32 x 14) x 2	(3 x 32 x 14) x 2
<b>Piping</b>			
Liquid Line Connection (in., OD) x Qty.	3/8 x 1	3/8 x 1	3/8 x 1
Vapor Line Connection (in., OD) x Qty.	3/4 x 1	3/4 x 1	3/4 x 1
Factory Charge lbs. of R410A	9.7	9.7	12.3
<b>Piping Lengths</b>			
Maximum Total System Piping (ft.) <sup>6</sup>	475.7	475.7	475.7
Maximum Main Pipe Length (Outdoor Unit to BD Unit (ft.))	180.4	180.4	180.4
Total Branch Piping (BD Units to all Indoor Units (ft.))	295.3	295.3	295.3
Maximum Branch Pipe Length (Length between each BDU and IDU (ft.))	49.2	49.2	49.2
Maximum Outdoor Unit to Indoor Unit Pipe Length (ft.)	229.6	229.6	229.6
Max. Main Piping Length (No Additional Refrigerant (ft.))	16	16	16
Max. Branch Piping Length (No Additional Refrigerant (ft.))	131	131	147.6
Maximum Elevation between Outdoor Unit and Indoor Unit (ft.)	98.4	98.4	98.4
Maximum Elevation between Indoor Unit and Indoor Unit (ft.)	49.2	49.2	49.2
Maximum Elevation between BD Unit and Indoor Unit (ft.)	32.8	32.8	32.8
Maximum Elevation between BD Unit and BD Unit (ft.)	49.2	49.2	49.2

<sup>1</sup>Rated capacity applied with non-ducted indoor units, and is rated 0 ft. above sea level with a 0 ft. level difference between outdoor and indoor units. All capacities are net with a combination ratio between 95 – 105%.

Rated cooling capacity obtained with air entering the indoor unit at 80°F dry bulb (DB) and 67°F wet bulb (WB) and outdoor ambient conditions of 95°F dry bulb (DB) and 75°F wet bulb (WB). Rated heating capacity obtained with air entering the indoor unit at 70°F dry bulb (DB) and 60°F wet bulb (WB) and outdoor ambient conditions of 47°F dry bulb (DB) and 43°F wet bulb (WB).

<sup>2</sup>At least one Branch Distribution Unit is required for system operation; a maximum of two can be installed per outdoor unit with use of Y-branch accessory (PMBL5620). At least two indoor units should be connected. For allocated capacity information, see the combination tables in the "Multi F / Multi F MAX Combination Data Manual" on www.lg-dfs.com. For performance data, see "Multi F / Multi F MAX Performance Data Manual" on www.lg-dfs.com.

<sup>3</sup>Sound pressure levels are tested in an anechoic chamber under ISO Standard 3745. These values can increase due to ambient conditions during operation.

<sup>4</sup>Power wiring to the outdoor unit is field supplied, solid or stranded, and must comply with the applicable local and national codes. For detailed information, please refer to electrical characteristics on page 11.

<sup>5</sup>All power wiring / communication cable to be minimum 16 AWG from the outdoor unit to the BD unit (Multi F MAX systems only), and 18 AWG from the BD unit to the indoor unit, stranded, shielded or unshielded (if shielded, it must be grounded to the chassis of the outdoor unit only), and must comply with applicable local and national codes. For detailed electrical information, please refer to electric characteristics on page 11.

<sup>6</sup>Piping lengths are equivalent.

<sup>7</sup>Installation of an optional Low Ambient Wind Baffle Kit will allow operation down to -4°F in cooling mode.

# SPECIFICATIONS

## Multi F MAX Branch Distribution Units

**MULTI F**  
**MULTI F MAX**

Table 3: Multi F MAX BD Unit General Data.

Model Number	PMBD3620	PMBD3630	PMBD3640	PMBD3641
No. of Connectible Indoor Units <sup>1</sup>	1-2	1-3	1-4	1-4
Max. Nominal Capacity / Port (Btu/h) <sup>2</sup>	24,000	24,000	24,000	24,000 for A,B,C Ports; 36,000 for D Port
Max. Nominal Capacity / BD Unit (Btu/h)	48,000	72,000	73,000	73,000
Operation Temperature Range (°F DB)	0 ~ 150	0 ~ 150	0 ~ 150	0 ~ 150
<b>Unit Data</b>				
Refrigerant Type	R410A	R410A	R410A	R410A
Power Supply V, Ø, Hz	208-230, 1, 60	208-230, 1, 60	208-230, 1, 60	208-230, 1, 60
Power Input (W)	16	24	32	32
Rated Amps (A)	0.08	0.12	0.16	0.16
Dimensions W x H x D (in.)	17-3/32 x 6-13/32 x 10-23/32	17-3/32 x 6-13/32 x 10-23/32	17-3/32 x 6-13/32 x 10-23/32	17-3/32 x 6-13/32 x 10-23/32
Net Unit Weight (lbs.)	13	14.3	15.7	15.7
Shipping Weight (lbs.)	15	17	18	18
<b>Power Wiring / Communication Cables<sup>3</sup></b>				
From Outdoor Unit to BD Unit (Qty. x AWG) <sup>3</sup>	4 x 16	4 x 16	4 x 16	4 x 16
From BD Unit to Indoor Unit (Qty. x AWG) <sup>3</sup>	4 x 18	4 x 18	4 x 18	4 x 18
<b>Piping Connections</b>				
Outdoor Unit to BD Unit	Liquid (in., OD)	Ø3/8	Ø3/8	Ø3/8
	Vapor (in., OD)	Ø3/4	Ø3/4	Ø3/4
BD Unit to Indoor Units	Liquid (in., OD) x Qty.	Ø1/4 x 2	Ø1/4 x 3	Ø1/4 x 4
	Vapor (in., OD) x Qty.	Ø3/8 x 2	Ø3/8 x 3	Ø3/8 x 4 Ø1/2 x 1
<b>Piping Lengths</b>				
Maximum Total System Piping (ft.) <sup>4</sup>	475.7	475.7	475.7	475.7
Maximum Main Pipe Length (Outdoor Unit to BD Units [ft.])	180.4	180.4	180.4	180.4
Maximum Total Branch Piping (BD Units to Indoor Units [ft.])	295.3	295.3	295.3	295.3
Maximum Branch Pipe Length Between BD Unit and Each Indoor Unit [ft.]	49.2	49.2	49.2	49.2
Maximum Outdoor Unit to Indoor Unit Pipe Length (ft.)	229.6	229.6	229.6	229.6
Main Piping Length (No Additional Refrigerant [ft.])	16	16	16	16
Branch Piping Length (No Additional Refrigerant [ft.])	131	131	131	131
Maximum Elevation between BD Unit and Indoor Unit (ft.)	32.8	32.8	32.8	32.8
Maximum Elevation between BD Unit and BD Unit (ft.)	49.2	49.2	49.2	49.2

<sup>1</sup>At least one Branch Distribution Unit is required for system operation; a maximum of two can be installed per outdoor unit with use of Y-branch accessory (PMBL5620) To connect only one (1) indoor unit to a branch distribution unit, the system must include another branch distribution unit with at least one (1) connected indoor unit.

<sup>2</sup>Branch Distribution Unit can accommodate from one (1) indoor unit up to four (4) indoor units depending on the ports available on the Branch Distribution Unit.

<sup>3</sup>All power wiring / communication cable to be minimum 16 AWG from the outdoor unit to the BD unit (Multi F MAX systems only), and 18 AWG from the BD unit to the indoor unit, stranded, shielded or unshielded (if shielded, it must be grounded to the chassis of the outdoor unit only), and must comply with applicable local and national codes. For detailed electrical information, please refer to electric characteristics on page 11.

<sup>4</sup>Piping lengths are equivalent.

Table 4: Multi F Outdoor Unit Electrical Data.

Nominal Tons	Unit Model No.	Hertz	Voltage	Phase	Voltage Range (Min. to Max.)	MCA	MOP	Compressor Quantity	Compressor Motor RLA	Outdoor Fan Motor		Indoor Fan Motor
										kW	FLA	FLA
1.5	LMU18CHV	60	208 - 230	1	187 - 253	13.3	20	1	8.9	0.09	0.59	1.60
2	LMU24CHV					14.3	20	1	9.4	0.09	0.59	2.00
2.5	LMU30CHV					16.6	25	1	10.8	0.12	0.73	2.40
3	LMU36CHV					17.9	25	1	11.2	0.12	0.73	3.20

Voltage tolerance is ±10%.

Maximum allowable voltage unbalance is 2%.

RLA = Rated Load Amps.

MCA = Minimum Circuit Ampacity.

Maximum Overcurrent Protection (MOP) is calculated as follows: (Largest motor FLA x 2.25) + (Sum of other motor FLA) rounded down to the nearest standard fuse size.

Indoor Fan Motor (FLA) is based on the maximum combination of indoor units.

The max combination for each outdoor unit is:

- 18,000 ODU (LMU18CHV): 12,000 IDU x 2
- 24,000 ODU (LMU24CHV): 12,000 IDU x 2 + 9,000 IDU x 1
- 30,000 ODU (LMU30CHV): 12,000 IDU x 3
- 36,000 ODU (LMU36CHV): 12,000 IDU x 4

Table 5: Multi F MAX Electrical Data.

Nominal Tons	Unit Model No.	Hertz	Voltage	Phase	Voltage Range (Min. to Max.)	MCA	MOP	Compressor Quantity	Compressor Motor RLA	Condenser Fan Motor(s)		Indoor Fan Motor
										Condenser Fan Quantity x kW	Condenser Fan Motor FLA	
4.0	LMU480HV	60	208 - 230	1	187 - 253	27.3	40	1	17.5	2 x 0.12	0.73 x 2	4.0
4.5	LMU540HV	60	208 - 230		187 - 253	29.4	40	1	18.5	2 x 0.12	0.73 x 2	4.8
5.0	LMU600HV	60	208 - 230		187 - 253	32.2	45	1	20.4	2 x 0.12	0.73 x 2	5.2

Voltage tolerance is ±10%.

Maximum allowable voltage unbalance is 2%.

RLA = Rated Load Amps.

MCA = Minimum Circuit Ampacity.

Maximum Overcurrent Protection (MOP) is calculated as follows: (Largest motor FLA x 2.25) + (Sum of other motor FLA) rounded down to the nearest standard fuse size.

Indoor Fan Motor (FLA) is based on the maximum combination of indoor units.

The max combination for each outdoor unit is:

- 48,000 ODU (LMU480HV): 12,000 IDU x 5
- 54,000 ODU (LMU540HV): 12,000 IDU x 6
- 60,000 ODU (LMU600HV): 12,000 IDU x 6 + 9,000 IDU x 1

---

---

## R410A Refrigerant

R410A refrigerant has a higher operating pressure in comparison to R22 refrigerant and, therefore, all piping system materials installed must have a higher resisting pressure than the materials traditionally used in R22 systems.

R410A refrigerant is an azeotrope of R32 and R125, mixed at 50:50, so the ozone depletion potential (ODP) is 0.

### **⚠ WARNING**

⊘ Do not place refrigerant cylinder in direct sunlight. Refrigerant cylinder may explode causing severe injury or death.

### **Note**

- Because R410A is a combination of R32 and R125, the required additional refrigerant must be charged in its liquid state. If the refrigerant is charged in its gaseous state, its composition changes and the system will not work properly.
- ⊘ Do not heat piping more than necessary during installation. Piping may become soft and fail when pressurized.
- ⊘ Do not use any piping that has not been approved for use in high-pressure refrigerant systems. Piping wall thickness must comply with the applicable local, state, and federal codes for the 551 psi design pressure of R410A. Inadequate piping may fail when pressurized.

### Selecting the Best Location for the Outdoor Unit

#### ⚠ DANGER

To avoid the possibility of fire, do not install the unit in an area where combustible gas may generate, flow, stagnate, or leak. Failure to do so will cause serious bodily injury or death.

#### Note:

Before beginning installation, read the safety summary at the beginning of this manual.

#### ⚠ WARNING

⊘ Do not install the unit in a location where acidic solution and spray (sulfur) are often used as this may cause serious bodily injury or death. ⊘ Do not use the unit in environments where oil, steam, or sulfuric gas are present as this may cause serious bodily injury or death.

#### ⚠ CAUTION

When deciding on a location to place the outdoor unit, be sure to choose an area where run-off from defrost will not accumulate and freeze on sidewalks or driveways which may create unsafe conditions.

#### Note:

Select a location for installing the outdoor unit that will meet the following general conditions:

- A location strong enough to bear the weight of the outdoor unit.
- A location that allows for optimum air flow and is easily accessible for inspection, maintenance, and service.
- Where piping between the outdoor unit, indoor unit(s), and BD units (Multi F MAX systems only) are within allowable limits.
- Include space for drainage to ensure condensate flows properly out of the unit when it is in heating mode. Avoid placing the outdoor unit in a low-lying area where water could accumulate.



- Where it will not be subjected to direct thermal radiation from other heat sources, nor an area that would not expose the outdoor unit to heat or steam like discharge from boiler stacks, chimneys, steam relief ports, other air conditioning units, kitchen vents, plumbing vents, and other sources of extreme temperatures.
- Where high-frequency electrical noise / electromagnetic waves will not affect operation.
- Where operating sound from the unit will not disturb inhabitants of surrounding buildings.
- Where the unit will not be exposed to direct, strong winds.

### Oceanside Installation Precautions

- Avoid installing the outdoor unit where it would be directly exposed to ocean winds.
- Install the outdoor unit on the side of the building opposite from direct ocean winds.
- Select a location with good drainage.
- Periodically clean dust or salt particles off of the heat exchanger with water.

#### Note:

Ocean winds may cause corrosion, particularly on the condenser and evaporator fins, which, in turn could cause product malfunction or inefficient performance.

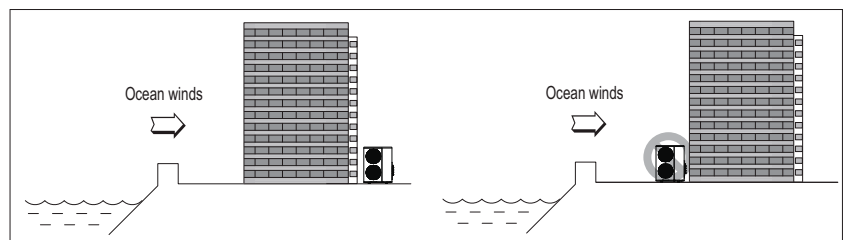

#### Note:

Additional anti-corrosion treatment may need to be applied to the outdoor unit at oceanside locations.

If the outdoor unit must be placed in a location where it would be subjected to direct ocean winds, install a concrete windbreaker strong enough to block any winds. Windbreaker height and width should be more than 150% of the outdoor unit, and be installed at least 27-1/2 inches away from the outdoor unit to allow for airflow.

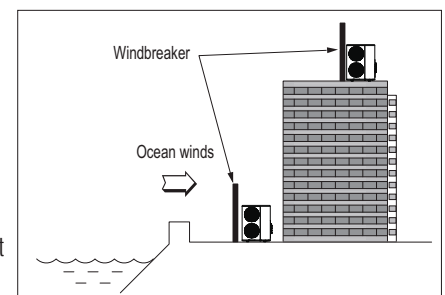

### Rooftop Installations

If the outdoor unit is installed on a roof structure, be sure to level the unit. Ensure the roof structure and anchoring method are adequate for the unit location. Consult local codes regarding rooftop mounting.

### Planning for Snow and Ice

In climates that experience snow buildup, place the unit on a raised platform to ensure proper condenser airflow. The raised support platform must be high enough to allow the unit to remain above possible snow drifts. Mount the unit on a field-provided stand that is higher than the maximum anticipated snowfall for the location. Design the mounting base to prevent snow accumulation on the platform in front or back of the unit case. If necessary, provide a field fabricated hood to keep snow and ice and/or drifting snow from accumulating on the coil surfaces. Use inlet and discharge duct or hoods to prevent snow or rain from accumulating on the fan inlet and outlet guards. Best practice prevents snow from accumulating on top of the unit. Consider tie-down requirements in case of high winds or where required by local codes.

### ⚠ CAUTION

*When deciding on a location to place the outdoor unit, be sure to choose an area where run-off from defrost will not accumulate and freeze on sidewalks or driveways which may create unsafe conditions.*

### Tie-Downs and Lightning Protection

#### Tie-Downs

- The strength of the roof must be checked before installing the outdoor units.
- If the installation site is prone to high winds or earthquakes, when installing on the wall or roof, securely anchor the mounting base using a field-provided tie-down configuration approved by a local professional engineer.
- The overall tie-down configuration must be approved by a local professional engineer. Always refer to local code when using a wind restraint system.

#### Lightning Protection

- To protect the outdoor unit from lightning, it should be placed within the specified lightning safety zone.

Table 6: Safety Zone Specifications.

Building Height (feet)	66	98	148	197
Protection Angle (°)	55	45	35	25

- Power cable and communication cable should be installed five (5) feet away from lightning rod.
- A high-resistance ground system should be included to protect against induced lightning or indirect strike.

Figure 1: Lightning Protection Diagram.

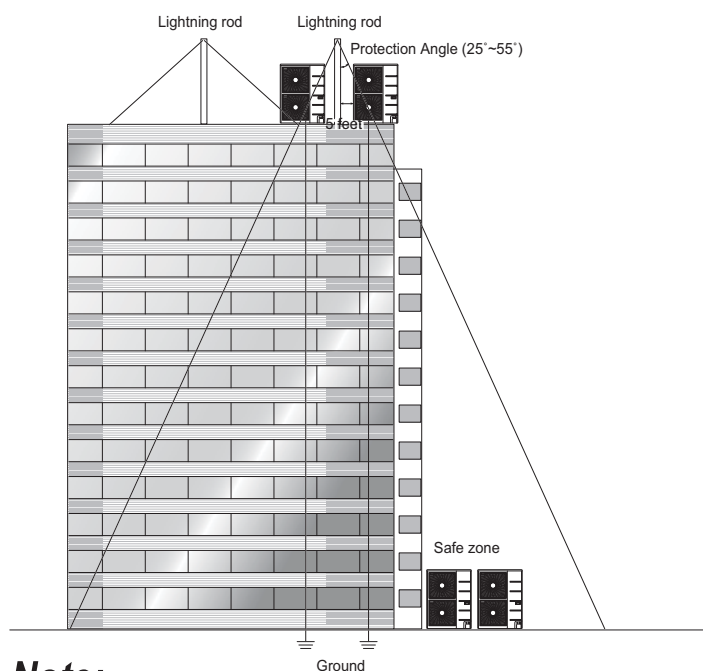

### Note:

*If the building does not include lightning protection, the outdoor unit may be damaged from a lightning strike. Inform the customer of this possibility in advance.*

### Outdoor Unit Service Access and Allowable Clearances

Appropriate airflow through the outdoor unit coil is critical for proper unit operation.

- Include enough space for airflow and for service access. If installing multiple outdoor units, avoid placing the units where the discharge of one unit will blow into the inlet side of an adjacent unit.
- No obstacles to air circulation around the unit; keep proper distances from ceilings, fences, floor, walls, etc. (Install a fence to prevent pests from damaging the unit or unauthorized individuals from accessing it.)
- If an awning is built over the unit to prevent direct sunlight or rain exposure, make sure that the discharge air of the outdoor unit isn't restricted.

When installing the outdoor unit, consider service, inlet, and outlet, and minimum allowable space requirements as illustrated in the following diagrams.

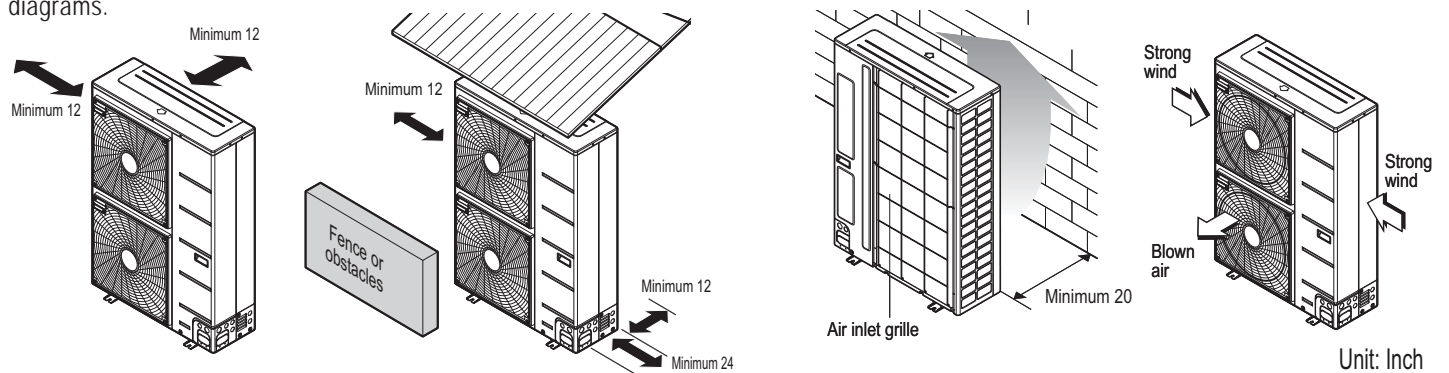

Ensure that the space at the back of the outdoor unit is a minimum of 11-13/16 inches, and include a minimum of 23-5/8 inches at the right side of the unit for service.

If the outdoor unit discharge side faces a wall, include a minimum of 19-11/16 inches between the outdoor unit and the wall. Install the outdoor unit so that the discharge port is set at a right angle to the wind direction.

### Clearance Requirements when Different Obstacles are Present (Unit: Inch)

Obstacle on the suction side only.

Obstacles on the suction side and on both left and right sides.

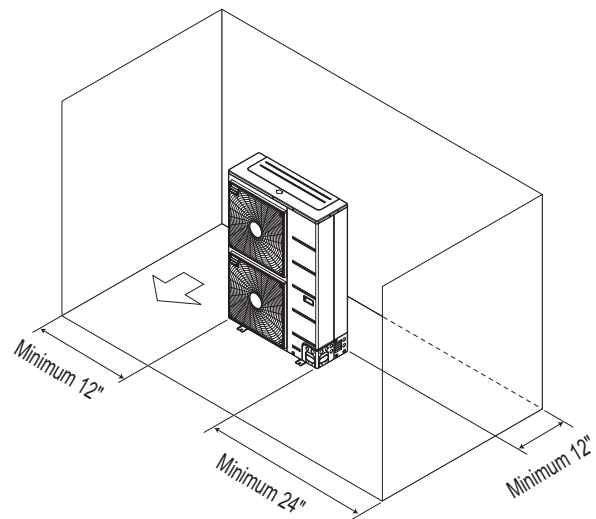
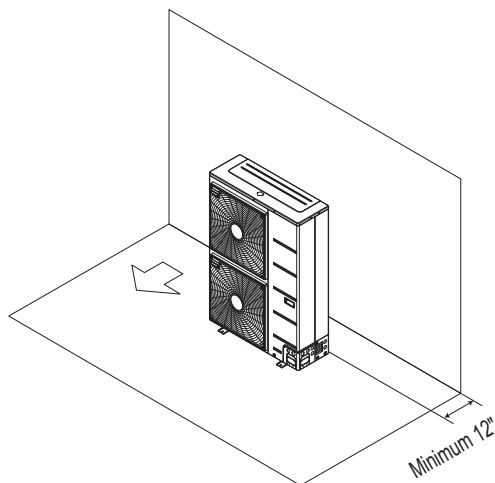

# GENERAL INSTALLATION GUIDELINES

MULTI F  
MULTI F MAX

## Allowable Clearances for Outdoor Unit

Clearance Requirements when Different Obstacles are Present, continued. (Unit: Inch)

Obstacles above and on the air intake side. Obstacles above, on the air intake side, and on both left and right sides

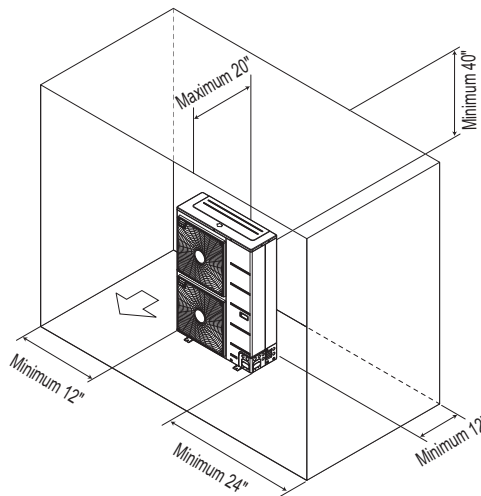
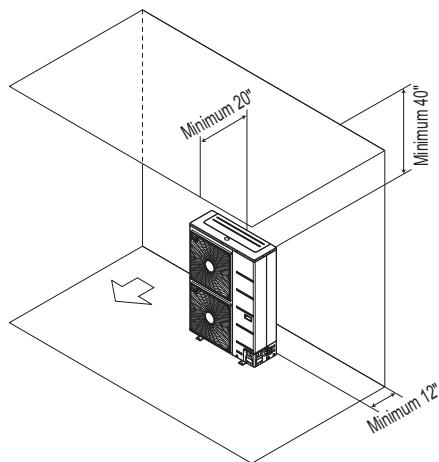

Obstacle just on the air discharge side.

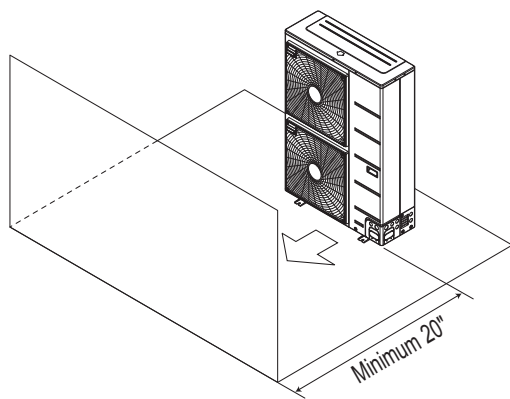

Obstacles above and on the air discharge side.

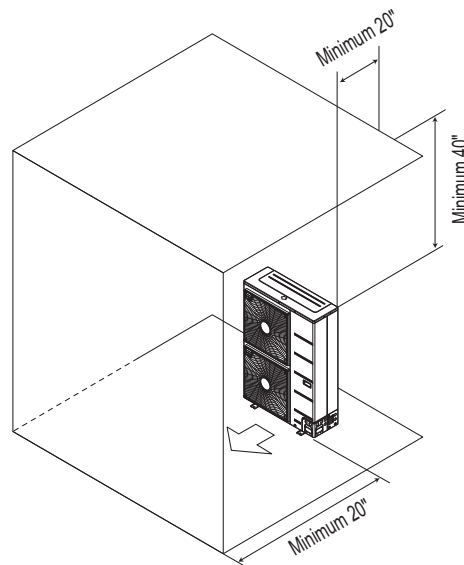

Where there are obstacles on both suction and discharge sides (discharge side obstacle is higher than the outdoor unit).

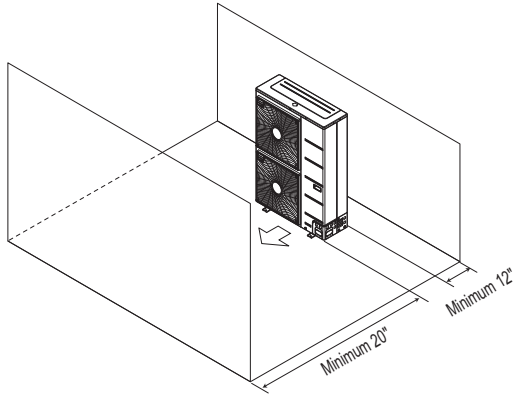

Where there are obstacles above, and on both suction and discharge sides (discharge side obstacle is higher than the outdoor unit).

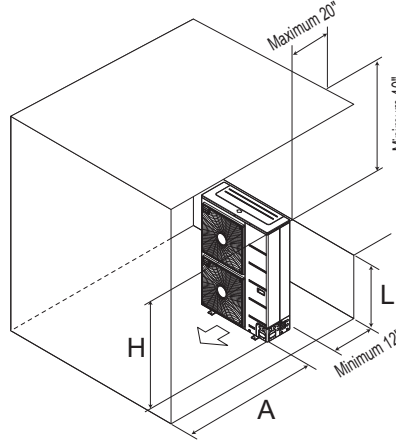
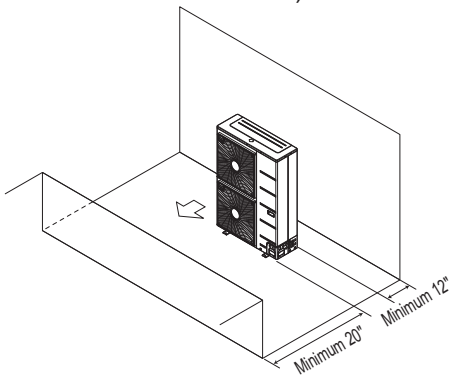

Table 7: Ratio among H, A, and L.

	L	A
L ≤ H	0 < L ≤ 1/2 H	30 inches
	1/2 H < L	40 inches
H < L	Set Stand as: L ≤ H	

If a stand is necessary, it should be contained (not open frame) to prevent the discharge air from short cycling.

Where there are obstacles on both suction and discharge sides (discharge side obstacle is lower than the outdoor unit).



Where there are obstacles above, and on both suction and discharge sides (discharge side obstacle is lower than the outdoor unit).

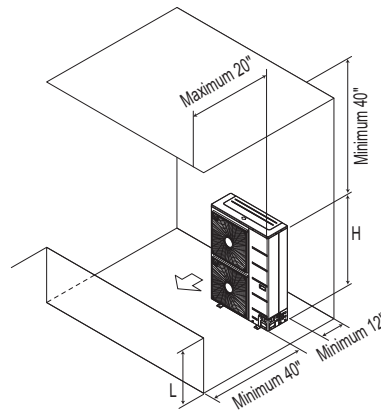

### Series installation

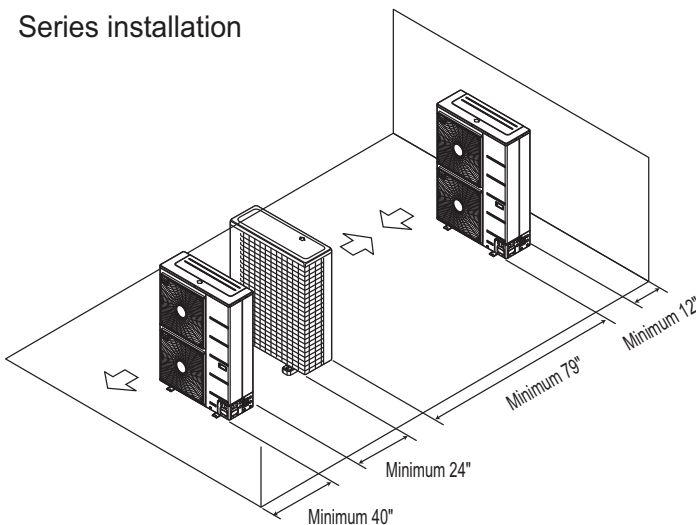

### Note:

"L" should be lower than "H". If a stand is necessary, it should be contained (not open frame) to prevent the discharge air from short cycling.

# GENERAL INSTALLATION GUIDELINES

Rigging Instructions / Platform Instructions for Outdoor Unit

MULTI F  
MULTI F MAX

## Rigging and Lifting Instructions

### ⚠ WARNING

Wear protective gloves when handling equipment. Sharp edges may cause personal injury.

Dispose the packing materials safely.

- Packing materials, such as nails and other metal or wooden parts, may cause puncture wounds or other injuries.
- Tear apart and throw away plastic packaging bags so that children may not play with them and risk suffocation and death.

### ⚠ CAUTION

Be very careful when transporting the product. There is a risk of the product falling and causing physical injury.

- Use appropriate moving equipment to transport each frame; ensure the equipment is capable of supporting the weights listed.
- Some products use polypropylene bands for packaging. Ⓞ Do not use polypropylene bands to lift the unit.
- Support the outdoor unit a minimum of four points to avoid slippage from rigging apparatus.

### Note:

- Make sure the outdoor unit is in its original packaging to avoid damage during local transport.
- At the time of delivery, the package should be checked for any damage (exterior and interior). Report any damage to the carrier claims agent immediately.
- Handle the outdoor unit with care. Keep the outdoor unit upright to avoid damaging inside components.
- If a forklift is to transport the outdoor unit, the forklift arms should pass through the openings at the bottom.
- If a crane is to suspend the outdoor unit, it is recommended that two (2) ropes at least twenty-three (23) feet in length be used.
- Pass the ropes under the unit. Pass the rope through the two (2) forklift slots each at the front and rear of the outdoor unit.
- To prevent damage to the outdoor unit, always lift the unit with the ropes attached at four (4) points at an angle of  $\leq 40^\circ$ .
- Always include padding to protect the outdoor unit from rope damage, and take into consideration the outdoor unit's center of gravity.

## Concrete Platform Specifications

- Concrete foundations should be made of one part cement, two parts sand, and four parts gravel.
- The surface of the foundation should be finished with mortar with rounded edges, and weather-proofed.

## Anchoring the Outdoor Unit

- Tightly anchor the outdoor unit with a bolt and nut to a concrete or rigid platform.
- When installing on a wall (with field-supplied brackets), roof, or rooftop, securely anchor the mounting platform with nails, taking into consideration the possibility of strong winds or earthquakes.
- If there is a possibility of vibration from the outdoor unit transmitting to the building, add an anti-vibration material to the platform.

Figure 2: Example of Using an Insert for a Hole in a Reinforced Concrete Beam.

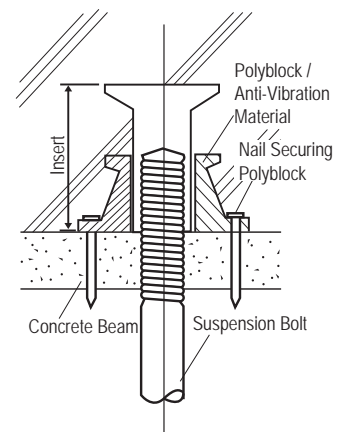
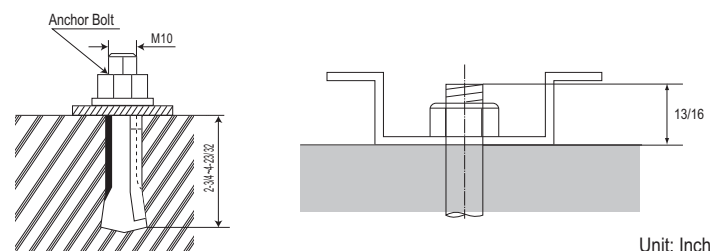

Figure 3: Close up of Bolt Attachment.



Unit: Inch

### Outdoor Unit Platform Requirements

Outdoor Unit Foundation Requirements.

Figure 4: LMU18CHV and LMU24CHV Outdoor Units.

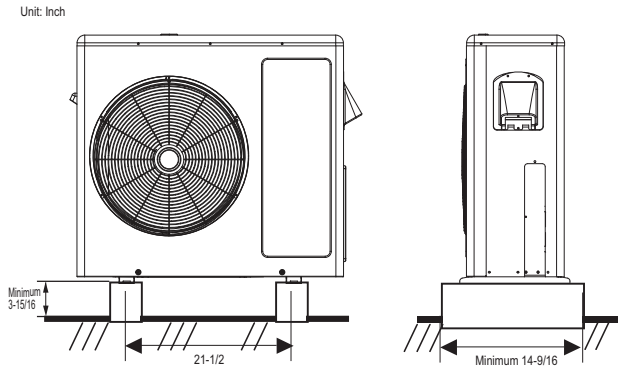

Figure 5: LMU30CHV and LMU36CHV Outdoor Units.

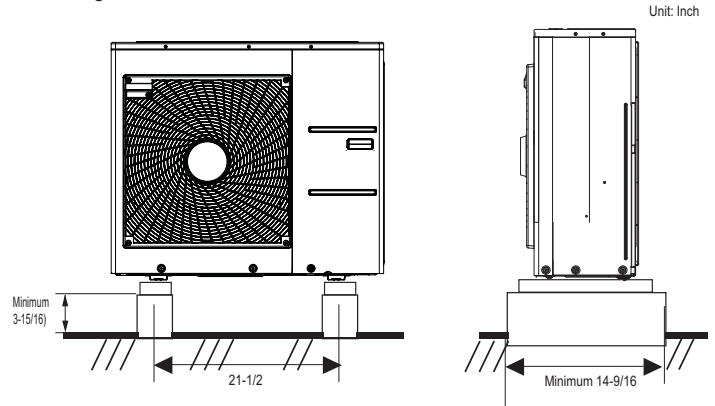

Figure 6: LMU480HV, LMU540HV, LMU600HV Outdoor Units.

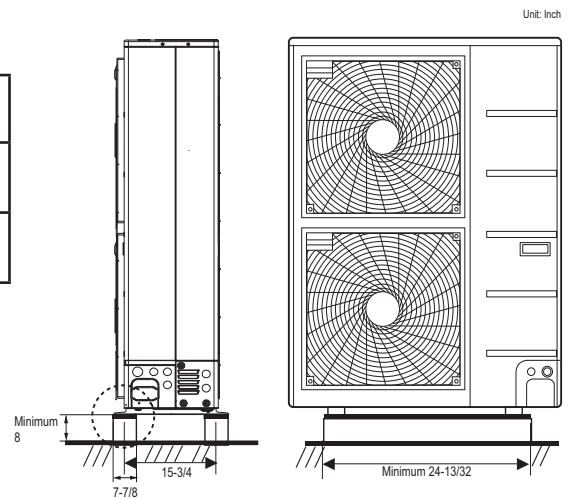

Table 8: Outdoor Unit Foundation Specifications.

Outdoor Unit Type	Bolt Type	Concrete Height	Bolt Depth
LMU18CHV, LMU24CHV, LMU30CHV, LMU36CHV	M10-J	Minimum 4 inches	Minimum 3 inches
LMU480HV, LMU540HV, LMU600HV	M10-J	Minimum 8 inches	Minimum 3 inches

### Bolting the Outdoor Unit to the Platform

1. Ensure that the concrete platform will not degrade easily, and has enough strength to bear the weight of the unit.
2. Include an H-beam support. Firmly attach the corners, otherwise the support will bend.
3. Use a hexagon nut.
4. Use anti-vibration material.
5. Include enough space around the concrete foundation for condensate drainage.
6. Seal all wiring and piping access holes to prevent bugs from entering the unit.

Figure 7: Bolting the Outdoor Unit to the Platform (Piping Location May Differ Depending on Outdoor Unit Model).

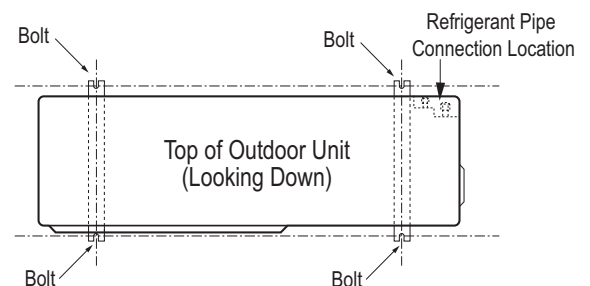

### Selecting the Best Location for the Branch Distribution (BD) Unit

#### Note:

Branch Distribution (BD) units are used only with Multi F MAX systems to distribute the refrigerant from the outdoor unit to up to eight indoor units. Select location indoors that will meet the following conditions:

- Within allowable parameters for proper connection to the Multi F MAX outdoor unit and indoor unit(s); refrigerant piping and wire lengths must not exceed amounts specified by LG Electronics, U.S.A., Inc.
- Condensate drain piping is not required.
- Ensure there is enough space in the installation area for service and inspection purposes (23-5/8 inch square opening).
- Install the refrigerant piping and electrical wiring system in an easily accessible location.
- Level where there is enough strength to bear the weight of the BD unit.
- Interior installation is highly recommended.
- Allowable operating temperature range: 0 ~ 150°F; Allowable maximum operating humidity range: 80%.
- Unit can be installed no more than  $\pm 5$  degrees of level.
-  Do not install the BD unit in a location where it would be subjected to strong radiation heat from heat sources.
- Avoid an installation environment where the BD unit would be exposed to heat, water, steam, oil splattering, spray or other factors that may damage the PCB.
- Install the unit in a location where any sound it generates will not disturb occupants in the surrounding rooms.
- No obstacles to air circulation around the unit; keep proper distances from ceilings, doorways, floor, walls, etc.
- Where high-frequency electrical noise / electromagnetic waves will not affect operation. Maintain proper distances between the BD unit(s) and electric wires, audio and visual appliances, breaker / circuit panels, etc.

Figure 8: Branch Distribution Unit Key Components.

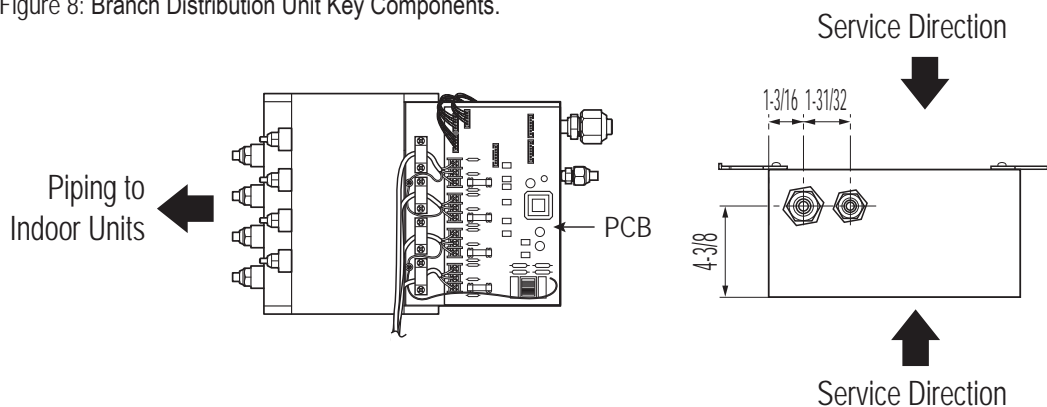
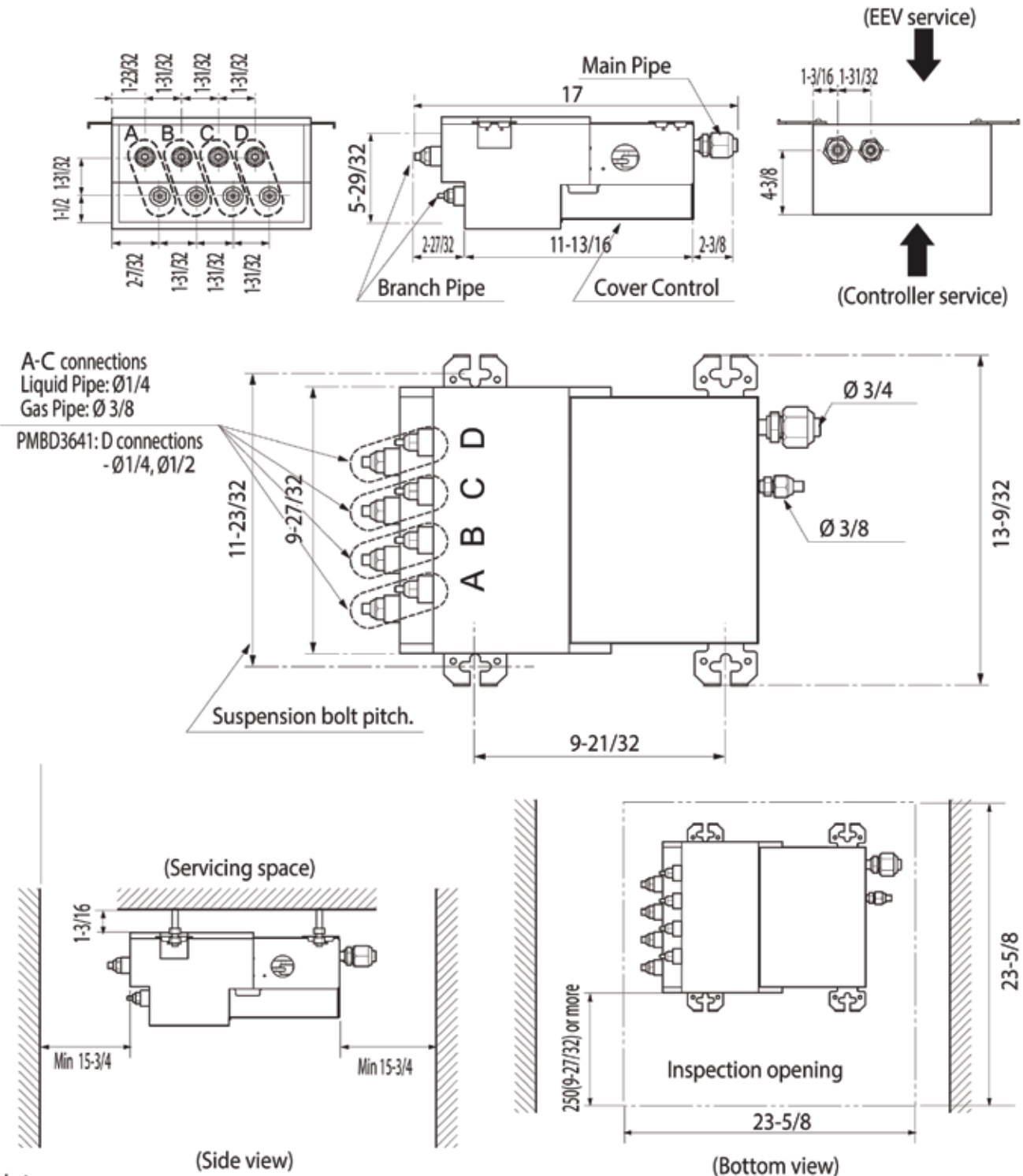

Figure 9: PMBD3620, PMBD3630, PMBD3640, and PMBD3641 External Dimensions.



**Notes**

1. For PMBD3620 unit, ports A and B are available.
2. For PMBD3630 unit, ports A, B and C are available.
3. For PMBD3640 and PMBD3641 units, ports A, B, C and D are available.

Unit : inch

### Branch Distribution Unit Orientation

Multi F MAX Branch Distribution (BD) Units can be installed in a multitude of options to fit various building configurations and job or application requirements. The installation location of the PCB within the BD unit can be changed for easier service access, depending on the BD unit installation itself (see the wiring section for information). Multi F MAX BD Units include electronic expansion valves that properly seat only if the BD Unit is installed in an acceptable orientation. Installations with improper BD Unit orientation risk incomplete valve seating and system performance degradation from potential refrigerant leakage through the electronic expansion valve.

**Note:**

*This material is for informational or educational purposes only. It is not intended to be a substitute for professional advice. Consult with your engineer or design professionals for specific applications to your system.*

### Ceiling Mount Installation - Hangers with Hanging Bolt

1. Drill four (4) holes in the ceiling, following the dimensions on the previous page.
2. Attach the factory-supplied hangers with two (2) screws each at the designated four (4) areas on the frame of the BD unit.
3. Install an anchor in the ceiling, and attach the hanging bolts to the ceiling.
4. Add nuts and washers to the hanging bolt as shown at right.
5. Hang the BD unit on the hanging bolts (ceiling side up), and after checking for level ( $\pm 5$  degrees), securely tighten all nuts.

Figure 11: BD Ceiling Mount Installation.

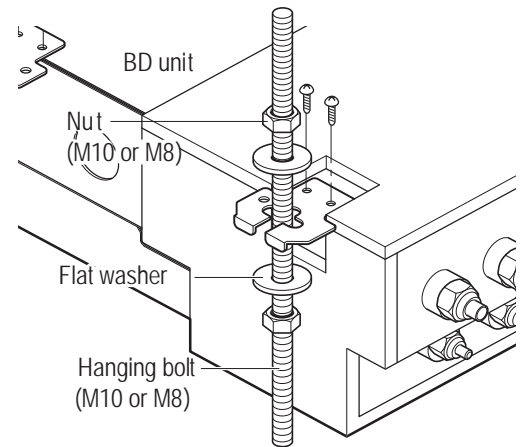

### Ceiling Mount Installation - Hangers Only

1. Attach the factory-supplied hangers with two (2) screws each at the designated four (4) areas on the frame of the BD unit.
2. Install the BD unit to the ceiling using two screws on each of the hangers as shown below. Unit should be  $\pm 5$  degrees of level.
3. Cover parts of the hanger holes with polyethylene foam insulation (to prevent condensation).

**Note:**

*If a screw has been installed on the frame of the BD unit and the screw has been removed, to prevent condensation, either re-install the screw or cover the open hole with aluminum tape.*

Figure 10: Acceptable BD Unit Ceiling Mount Orientations.

#### Ceiling Mounting Options

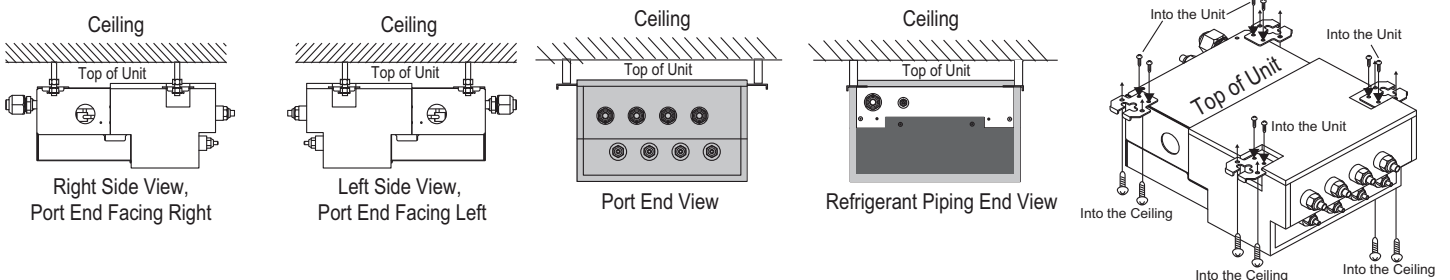

### Wall Mount Installation - Hangers Only

1. Attach the factory-supplied hangers with two (2) screws each at the designated four (4) areas on the frame of the BD unit.
2. Install the BD unit to the wall using two screws on each of the hangers. Unit should be  $\pm 5$  degrees of level.
3. Cover parts of the hanger holes with polyethylene foam insulation (to prevent condensation).

Figure 12: Acceptable BD Unit Wall Mount Orientations.

### Wall Mounting Options

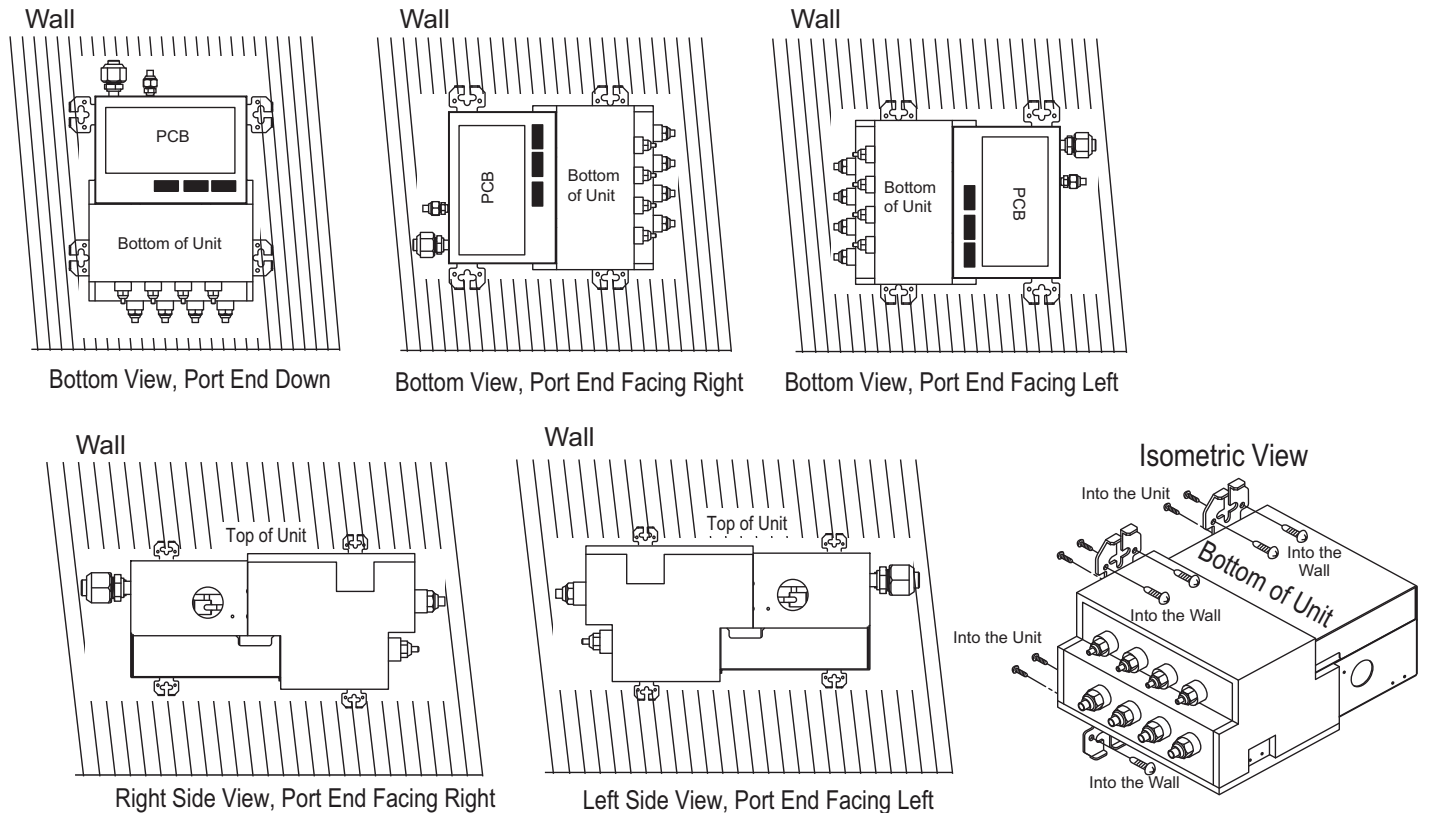
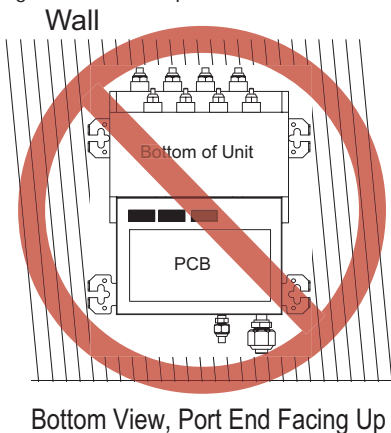

Figure 13: Unacceptable BD Unit Orientation.



# GENERAL INSTALLATION GUIDELINES

MULTI F  
MULTI F MAX

## Piping Preparation

### ⚠ WARNING

- ⓧ Do not allow the refrigerant to leak during brazing; if the refrigerant combusts, it generates a toxic gas.
- ⓧ Do not braze in an enclosed location, and always test for gas leaks before / after brazing.
- There is risk of fire, explosion, and physical injury or death.

### Outdoor Unit Pipe Connections

1. ⓧ Do not use kinked pipe caused by excessive bending in one specific area on its length.
2. Braze the pipes to the service valve pipe stub of the outdoor unit.
3. After brazing, check for refrigerant gas leaks.
4. When selecting flare fittings, always use a 45° fitting rated for use with high pressure refrigerant R410A. Selected fittings must also comply with local, state, or federal standards.

### Creating a Flare Fitting

One of the main causes of refrigerant leaks is defective flared connections. Create flared connections using the procedure below.

1. Cut the pipe to length.
  - Measure the distance between the indoor unit and the outdoor unit.
  - Cut the pipes a little longer than measured distance.

#### 2A. Remove the burrs

- Completely remove all burrs from pipe ends.
- When removing burrs, point the end of the copper pipe down to avoid introducing foreign materials in the pipe.

- 2B. Remove the flare nuts attached to the indoor and outdoor units. Slide the flare nut onto the copper tube.

#### 3. Flaring the pipe end.

- Use the proper size flaring tool to finish flared connections as shown.
- ALWAYS create a 45° flare when working with R410A.
- Firmly hold copper tube in a bar with a dimension as indicated in the table below.

#### 4. Carefully inspect the flared pipe end.

- Compare the geometry with the figures and dimensions as detailed.
- If the flare is defective, cut it off and re-do procedure.
- If flare looks good, blow clean the pipe with dry nitrogen.

Figure 14: Dimensions of the Flare.

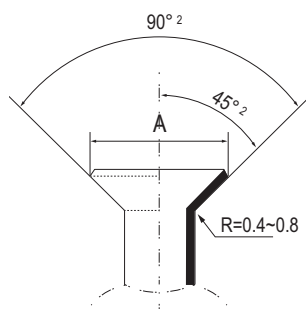
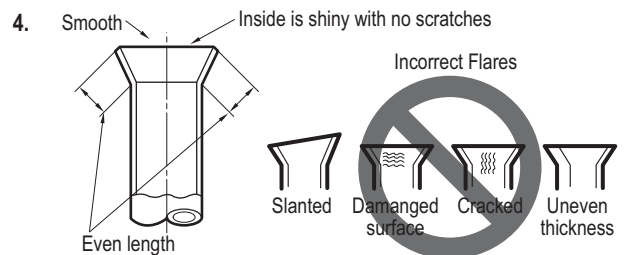
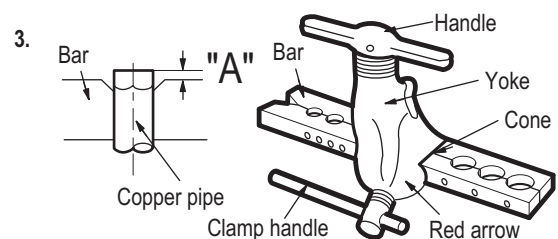
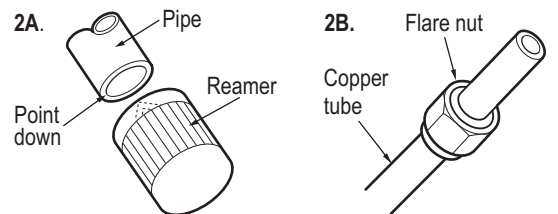
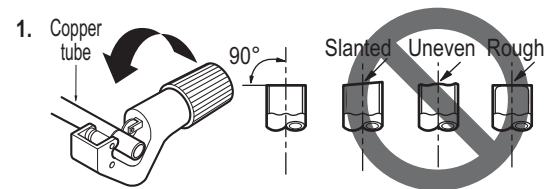

Table 9: Flared Connection Dimensions.

Outside Diameter	A
Inch	Inch
Ø1/4	0.04 ~ 0.05
Ø3/8	0.06 ~ 0.07
Ø1/2	0.06 ~ 0.07
Ø5/8	0.06 ~ 0.07
Ø3/4	0.07 ~ 0.08



### Tightening the Flare Connections

When connecting the flare nuts, coat the flare (outside only) with polyvinyl ether (PVE) refrigeration oil only.

**Note:**

⚠ Do not use polyolyster (POE) or any other type of mineral oil as a thread lubricant. These lubricants are not compatible with PVE oil used in this system and create oil sludge leading to equipment damage and system malfunction.

Table 10: Tightening Torque for Flare Nuts.

Pipe size (Inches O.D.)	Tightening torque (ft-lbs)
1/4Ø	13 ~ 18
3/8Ø	24.6 ~ 30.4
1/2Ø	39.8 ~ 47.7
5/8Ø	45.6 ~ 59.3
3/4Ø	71.6 ~ 87.5

Align the center of the piping, and initially hand tighten the flare nuts using three (3) or four (4) turns. For Multi F Outdoor Units, install the flare nuts by:

1. Connecting the Gas Piping for Connections A through D first.
2. Connecting the Liquid Piping for Connections A through D last.

Then, to finish tighten the flare nut using the torque wrench and a backup wrench, following the direction arrows on the wrench and using the appropriate tightening torque, until the wrench clicks. After all the piping has been connected, check for refrigerant gas leaks.

Figure 15: Flare Connection.

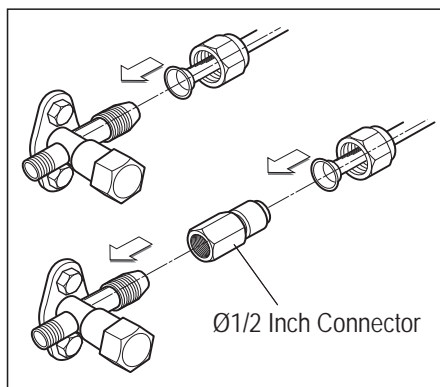

Figure 16: Example of Multi F Piping Connections.

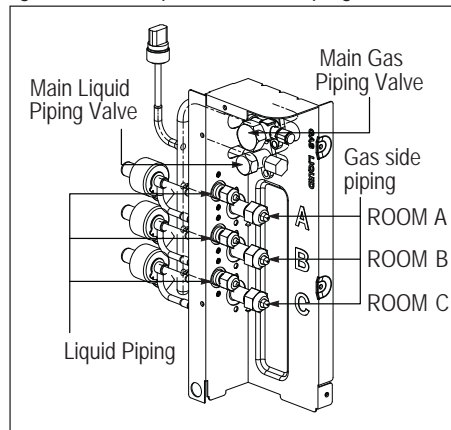
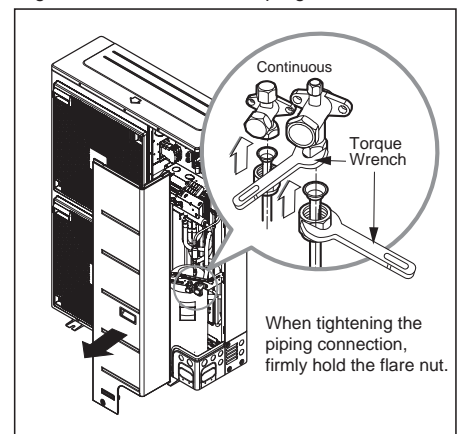

Figure 17: Multi F MAX Piping Connection.



For Multi F MAX outdoor units, piping can be installed in one of four directions: front, side, back, and down (A). If the downward installation is chosen, the knockout hole in the base pan must be accessed (B).

Whatever direction is chosen, plug the access holes with field-provided putty or insulation to fill all gaps (C).

**⚠ WARNING**

Insects or small animals entering the outdoor unit may cause a short circuit in the electrical box, which may lead to fire, electric shock, physical injury, or death.

**Note:**

Insects or small animals entering the outdoor unit may cause a short circuit in the electrical box, which may lead to unit failure.

Figure 18: Multi F MAX Piping Installation.

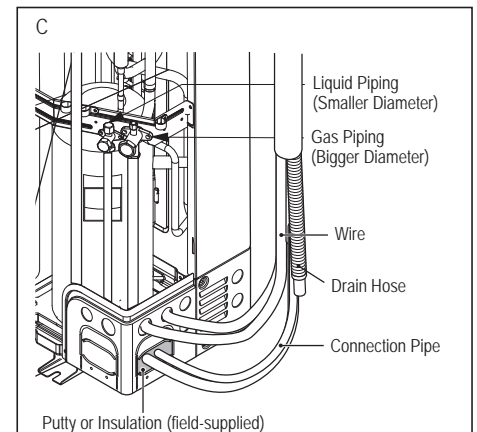
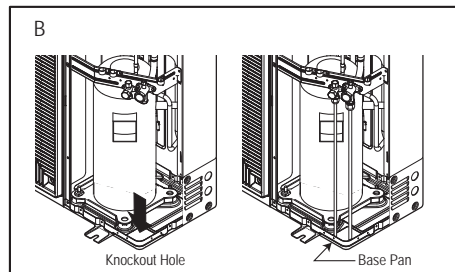
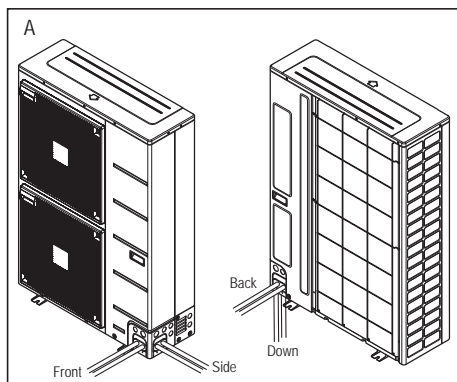

# GENERAL INSTALLATION GUIDELINES

MULTI F  
MULTI F MAX

## Piping Materials and Handling

### Loosening the Flare Nuts

Always use two (2) wrenches to loosen the flare nuts.

### Brazing Practices

**Note:**

Keep the piping system free of contaminants and debris such as copper burrs, slag, or carbon dust during installation. Contaminants can result in mechanical failure of the system.

All joints are brazed in the field. Multi F / Multi F MAX refrigeration system components contain very small capillary tubes, small orifices, electronic expansion valves, oil separators, and heat exchangers that can easily become blocked. Proper system operation depends on the installer using best practices and utmost care while assembling the piping system.



- While brazing, use a dry nitrogen purge operating at a minimum pressure of three (3) psig and maintain a steady flow.
- Blow clean all pipe sections with dry nitrogen prior to assembly.
- Use a tubing cutter. De-burr and clean all cuts before assembly.
- Store pipe stock in a dry place. Keep pipe capped and clean.
- Use adapters to assemble different sizes of pipe. Use a 15% silver phosphorous copper brazing alloy to avoid overheating and produce good flow.
- Protect isolation valves, electronic expansion valves, and other heat-sensitive control components from excessive heat with a wet rag or a heat barrier spray product.
-  Do not use flux, soft solder, or anti-oxidant agents.
-  Do not use a saw to cut pipe.

Figure 20: Refrigerant Pipe Brazing.



### Piping Materials and Handling

Pipes used for the refrigerant piping system must include the specified thickness, and the interior must be clean.

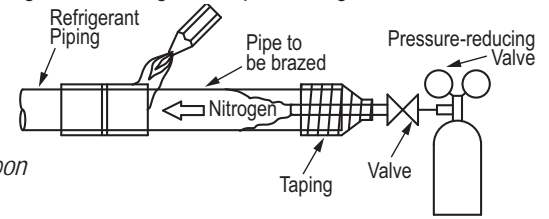
-  Do not bend or damage the pipes while handling and storing, and take care not to contaminate the interior with dust, moisture, etc. See Table 11 for care of piping.

Figure 19: Keep Piping Capped While Storing

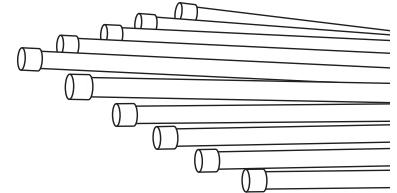
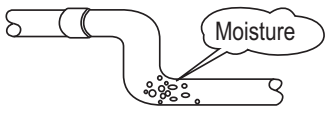
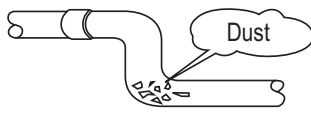
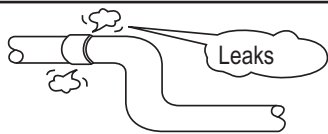



Table 11: Three Principles of Refrigerant Piping

	Dry	Clean	Airtight
Principles	No moisture should be inside the piping.	No dust should be inside the piping.	No leaks should occur.
			
Problems Caused	<ul style="list-style-type: none"> <li>- Significant hydrolysis of refrigerant oil.</li> <li>- Refrigerant oil degradation.</li> <li>- Poor insulation of the compressor.</li> <li>- System does not operate properly.</li> <li>- EEVs, capillary tubes are clogged.</li> </ul>	<ul style="list-style-type: none"> <li>- Refrigerant oil degradation.</li> <li>- Poor insulation of the compressor.</li> <li>- System does not operate properly.</li> <li>- EEVs and capillary tubes become clogged.</li> </ul>	<ul style="list-style-type: none"> <li>- Refrigerant gas leaks / shortages.</li> <li>- Refrigerant oil degradation.</li> <li>- Poor insulation of the compressor.</li> <li>- System does not operate properly.</li> </ul>
Solutions	<ul style="list-style-type: none"> <li>- Remove moisture from the piping.</li> <li>- Piping ends should remain capped until connections are complete.</li> <li>-  Do not install piping on a rainy day.</li> <li>- Connect piping properly at the unit's side.</li> <li>- Remove caps only after the piping is cut, the burrs are removed, and after passing the piping through the walls.</li> <li>- Evacuate system to a minimum of 500 microns and insure the vacuum holds at that level for 24 hours</li> </ul>	<ul style="list-style-type: none"> <li>- Remove dust from the piping.</li> <li>- Piping ends should remain capped until connections are complete.</li> <li>- Connect piping properly at the side of the unit.</li> <li>- Remove caps only after the piping is cut and burrs are removed.</li> <li>- Retain the cap on the piping when passing it through walls, etc.</li> </ul>	<ul style="list-style-type: none"> <li>- Test system for air tightness.</li> <li>- Perform brazing procedures that comply with all applicable standards.</li> <li>- Perform flaring procedures that comply with all applicable standards.</li> <li>- Perform flanging procedures that comply with all applicable standards.</li> <li>- Ensure that refrigerant lines are pressure tested to 550 psig.</li> </ul>

### Selecting Field-Supplied Copper Tubing

Type ACR copper is the only approved refrigerant pipe material for use with LG Multi F air conditioning products. ACR rated tubing is the only type that ships with yellow caps. Approved tubing for use with Multi F products will be marked "R410 RATED" along the length of the tube.

- Drawn temper (rigid) ACR copper tubing is available in sizes 3/8 through 2-1/8 inches (ASTM B 280, clean, dry, and capped).
- Annealed temper (soft) ACR copper tubing is available in sizes 1/4 through 2-1/8 inches (ASTM B 280, clean, dry, and capped).

**Note:**

Tube wall thickness should meet local code requirements and be approved for an operating pressure of 551 psi. If local code does not specify wall thickness, LG suggests using tube thickness per table below. When bending tubing, try to keep the number of bends to a minimum, and use the largest radii possible to reduce the equivalent length of installed pipe; also, bending radii greater than ten (10) pipe diameters can minimize pressure drop. Be sure no traps or sags are present when rolling out soft copper tubing coils.

Table 14: ACR Copper Tubing Material

Type	Seamless Phosphorous Deoxidized
Class	UNS C12200 DHP
Straight Lengths	H58 Temper
Coils	O60 Temper

Table 12: Piping Tube Thicknesses

OD (in)	1/4	3/8	1/2	5/8	3/4	7/8	1-1/8	1-3/8	1-5/8
Material	Rigid Type "K" or "L" and Soft ACR Acceptable			Rigid Type "K" or "L" Only					
Min. Bend Radius (in)	.563	.9375	1.5	3.0	3.0	3.0	3.5	4.0	4.5
Min. Wall Thickness (in)	.031	.031	.031	.039	.042	.045	.050	.050	.050

Table 13: ACR Copper Tubing Dimensions and Physical Characteristics<sup>1-4</sup>

Nominal Pipe Outside Diameter (in)	Actual Outside Diameter (in)	Drawn Temper			Annealed Temper		
		Nominal Wall Thickness (in)	Weight (lb/ft)	Cubic ft per Linear ft	Nominal Wall Thickness (in)	Weight (lb/ft)	Cubic ft per Linear ft
1/4	0.250	--	--	--	0.030	0.081	.00020
3/8	0.375	0.030	0.126	.00054	0.032	0.134	.00053
1/2	0.500	0.035	0.198	.00101	0.032	0.182	.00103
5/8	0.625	0.040	0.285	.00162	0.035	0.251	.00168
3/4	0.750	0.042	0.362	.00242	0.042	0.362	.00242
7/8	0.875	0.045	0.455	.00336	0.045	0.455	.00336
1-1/8	1.125	0.050	0.655	.00573	0.050	0.655	.00573

<sup>1</sup>All dimensions provided are in accordance with ASTM B280 – Standard.

<sup>2</sup>Design pressure = 551 psig.

<sup>3</sup>ACR Tubing is available as hard drawn or annealed (soft) and are suitable for use with R410A refrigerant.

<sup>4</sup>The Copper Tube Handbook, 2010, Copper Development Association Inc., 260 Madison Avenue, New York, NY 10016.

**Note:**

- Commercially available piping often contains dust and other materials. Always blow it clean with a dry inert gas.
- Prevent dust, water or other contaminants from entering the piping during installation. Contaminants can cause mechanical failure.

# GENERAL INSTALLATION GUIDELINES

MULTI F  
MULTI F MAX

## Piping Materials and Handling

### Multi F MAX Y-Branch Kit PMBL5620

The LG supplied Y-Branch Kit PMBL5620 **MUST** be used when two branch distribution units are connected on one Multi F MAX system. Field-supplied fittings are not permitted. Each Y-Branch kit comes with two (2) Y-branches (one for the liquid line and one for the vapor line) and insulation covers.

Y-branches may be installed in horizontal or vertical configurations. When installed vertically, position the Y-branch so the straight-through leg is  $\pm 3^\circ$  of plumb. When installed horizontally, position the Y-branch so the take-off leg is level and shares the same horizontal plane as the straight-through leg  $\pm 5^\circ$  rotation.

Y-branches must be properly installed following instructions in the applicable LG manual. Y-branches should always be installed with the single port facing the outdoor unit and the two-port end facing the branch distribution units.  Do not install Y-branches backwards as refrigerant flow cannot make U-turns. The Y-branch kit must be located at least three (3) feet from the outdoor unit. Provide a minimum of 20 inches between a Y-branch and the branch distribution unit.

It is recommended that when a Y-branch is located in a pipe chase or other concealed space, access doors should be provided for inspection access.

The equivalent pipe length of each Y-branch (1.6') must be added to the main pipe segment entered into LATS Multi F piping design software.

#### Note:

- Design pressure is 551 psig.
- All dimensions in inches. Tolerance  $\pm 1/4$  inch.
- Images are not to scale.

Figure 24: Horizontal Configuration End View.

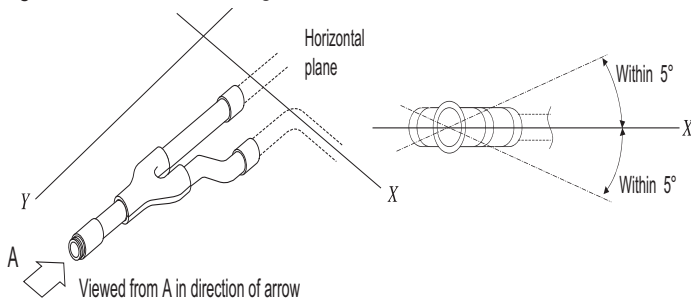

Figure 21: Y-Branch Connections.

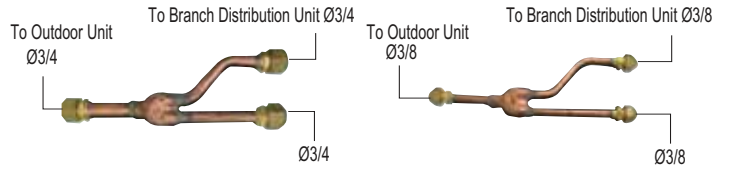

Table 15: Y-Branch Connection Diameters.

Model	Y-Branch Type	Port Identifier (inch)			Dimensions	
		1	2	3	X	Y
PMBL5620	Liquid	3/8	3/8	3/8	13.80	3.24
	Vapor	3/4	3/4	3/4	12.48	3.02

Figure 22: Y-Branch Port Identifier Diagram.

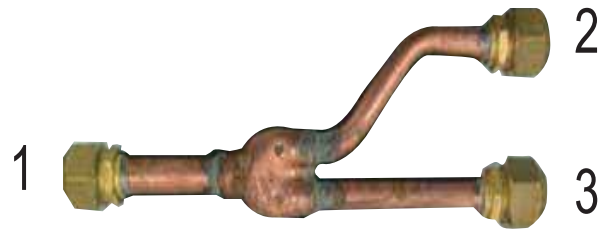

Figure 23: Y-Branch Dimensions Diagram.

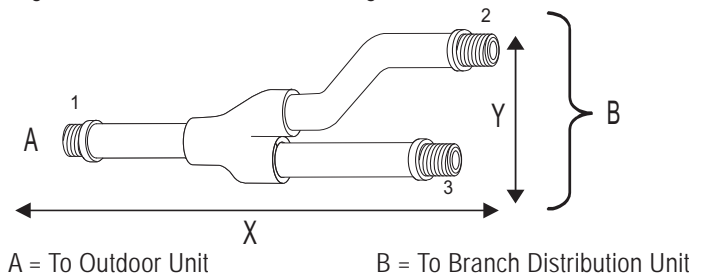
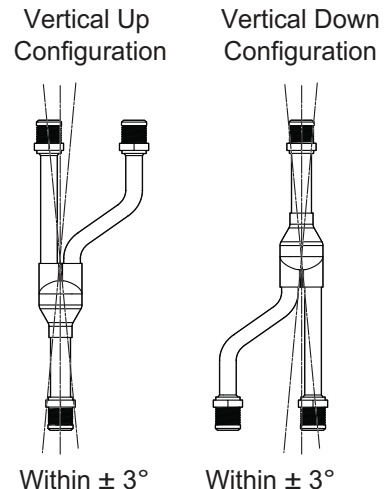

Figure 25: Y-branch Installation Alignment Specification.



### Y-Branch Kit Insulation

Each Y-branch kit comes with clam-shell type peel-and-stick insulation jackets molded to fit the Y-branch fittings—one for the liquid line, one for the vapor line.

- Check the fit of the Y-branch clam-shell insulation jacket after the Y-branch is installed.
- Mark the pipe where the insulation jacket ends.
- Remove the jacket.
- Install field-provided insulation on the pipes first.
- Peel the adhesive glue protector slip and install the clam-shell jacket over the fitting

Figure 26: Y-branch Insulation Detail.

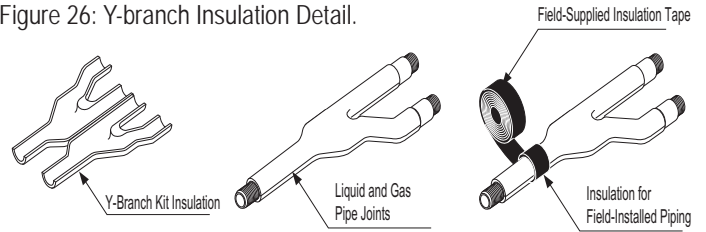

Table 16: Insulation Jacket Properties.

Material	Polyolefin Foam
UL94 Flame Classification	HF-1
Density	1.84 lbs./ft. <sup>3</sup>
Thermal Conductivity	.0208 Btu/h/ft. °R
Thickness	1/2 inch

### No Pipe Size Substitutions

Use only the pipe size selected by the LATS Multi F pipe system design software or as conveyed in the product installation instructions. Using a different size is prohibited and may result in a system malfunction or failure to work at all.

### Obstacles

When an obstacle, such as an I-beam or concrete T, is in the path of the planned refrigerant pipe run, it is best practice to route the pipe over the obstacle. If adequate space is not available to route the insulated pipe over the obstacle, then route the pipe under the obstacle. In either case, it is imperative the horizontal section of pipe above or below the obstacle be a minimum of three (3) times greater than the longest vertical rise (or fall) distance.

Figure 27: Installing Piping Above and Below an Obstacle.

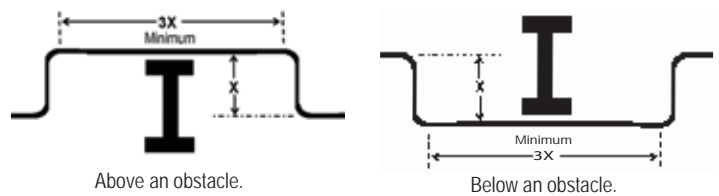

### Copper Expansion and Contraction

Under normal operating conditions, the vapor pipe temperature of a Multi F system can vary as much as 180°F. With this large variance in pipe temperature, the designer must consider pipe expansion and contraction to avoid pipe and fitting fatigue failures.

Refrigerant pipe, along with the insulation jacket, form a cohesive unit that expands and contracts together. During system operation, thermal heat transfer occurs between the pipe and the surrounding insulation.

If the pipe is mounted in free air space, no natural restriction to movement is present if mounting clamps are properly spaced and installed. When the refrigerant pipe is mounted underground in a utility duct stacked among other pipes, natural restriction to linear movement is present. In extreme cases, the restrictive force of surface friction between insulating jackets could become so great that natural expansion ceases and the pipe is "fixed" in place. In this situation, opposing force caused by change in refrigerant fluid/vapor temperature can lead to pipe/fitting stress failure.

The refrigerant pipe support system must be engineered to allow free expansion to occur. When a segment of pipe is mounted between two fixed points, provisions must be provided to allow pipe expansion to naturally occur. The most common method is the inclusion of expansion Loop or U-bends mounted in the horizontal plane. When expansion loops are placed in a vertical riser, the loop is to be formed in a horizontal fashion resulting in a torsional movement during expansion and contraction. Each segment of pipe has a natural fixed point where no movement occurs. This fixed point is located at the center point of the segment assuming the entire pipe is insulated in a similar fashion. The natural fixed point of the pipe segment is typically where the expansion Loop or U-bend should be. Linear pipe expansion can be calculated using the following formula:

$$LE = C \times L \times (T_r - T_a) \times 12$$

LE	=	Anticipated linear tubing expansion (in.)
C	=	Constant (For copper = $9.2 \times 10^{-6}$ in./in.°F)
L	=	Length of pipe (ft.)
T <sub>R</sub>	=	Refrigerant pipe temperature (°F)
T <sub>a</sub>	=	Ambient air temperature (°F)
12	=	Inches to feet conversion (12 in./ft.)

1. From Table 17, find the row corresponding with the actual length of the straight pipe segment.
2. Estimate the minimum and maximum temperature of the pipe. Typical pipe temperature change range: High Pressure Vapor: ambient temperature to 215°F; Low Pressure Vapor: ambient to 35°F; Liquid pipe: ambient, 80°F, 110°F. Choose the two most extreme. In the column showing the minimum pipe temperature, look up the anticipated expansion distance. Do the same for the maximum pipe temperature.
3. Calculate the difference in the two expansion distance values. The result will be the anticipated change in pipe length.

#### Example:

A Multi F MAX system is installed and the design shows that there is a 100 foot straight segment of tubing between a Y-branch and a branch distribution unit. The system operates 24 hours per day. In heating, this pipe transports hot gas vapor to the indoor units at 120°F. In cooling, the same tube is a suction line returning refrigerant vapor to the outdoor unit at 40°F. Look up the copper tubing expansion at each temperature and calculate the difference.

#### Vapor Line

Transporting Hot Vapor: 100 ft. pipe at 120°F = 1.40 in.  
 Transporting Suction Vapor: 100 ft. pipe at 40°F = 0.40 in.  
 Anticipated Change in Length: 1.40 in. – 0.40 in. = 1.00 in.

#### Liquid Line

The liquid temperature remains the same temperature; only the direction of flow will reverse. Therefore, no significant change in length of the liquid line is anticipated.

When creating an expansion joint, the joint depth should be a minimum of two times the joint width. Although different types of expansion arrangements are available, the data for correctly sizing an expansion loop is provided in Table 18. Use soft copper with long radius bends on longer runs or long radius elbows for shorter pipe segments. Using the anticipated linear expansion (LE) distance calculated, look up the Expansion Loop or U-bend minimum design dimensions. If other types of expansion joints are chosen, design per ASTM B-88 Standards.

Table 17: Linear Thermal Expansion of Copper Tubing in Inches.

Pipe Length <sup>1</sup>	Fluid Temperature °F																			
	35°	40°	45°	50°	55°	60°	65°	70°	75°	80°	85°	90°	95°	100°	105°	110°	115°	120°	125°	130°
10	0.04	0.04	0.05	0.06	0.06	0.07	0.08	0.08	0.09	0.09	0.10	0.10	0.11	0.11	0.11	0.12	0.13	0.14	0.15	0.15
20	0.08	0.08	0.10	0.12	0.13	0.14	0.15	0.16	0.17	0.18	0.19	0.20	0.21	0.22	0.22	0.23	0.26	0.28	0.29	0.30
30	0.12	0.12	0.15	0.18	0.20	0.21	0.23	0.24	0.26	0.27	0.29	0.30	0.32	0.33	0.32	0.35	0.39	0.42	0.44	0.45
40	0.16	0.16	0.20	0.24	0.26	0.28	0.30	0.32	0.34	0.36	0.38	0.40	0.42	0.44	0.43	0.46	0.52	0.56	0.58	0.60
50	0.20	0.20	0.25	0.30	0.33	0.35	0.38	0.40	0.43	0.45	0.48	0.50	0.53	0.55	0.54	0.58	0.65	0.70	0.73	0.75
60	0.24	0.24	0.30	0.36	0.39	0.42	0.45	0.48	0.51	0.54	0.57	0.60	0.63	0.66	0.65	0.69	0.78	0.84	0.87	0.90
70	0.28	0.28	0.35	0.42	0.46	0.49	0.53	0.56	0.60	0.63	0.67	0.70	0.74	0.77	0.76	0.81	0.91	0.98	1.02	1.05
80	0.32	0.32	0.40	0.48	0.52	0.56	0.60	0.64	0.68	0.72	0.76	0.80	0.84	0.88	0.86	0.92	1.04	1.12	1.16	1.20
90	0.36	0.36	0.45	0.54	0.59	0.63	0.68	0.72	0.77	0.81	0.86	0.90	0.95	0.99	0.97	1.04	1.17	1.26	1.31	1.35
100	0.40	0.40	0.50	0.60	0.65	0.70	0.75	0.80	0.85	0.90	0.95	1.00	1.05	1.10	1.08	1.15	1.30	1.40	1.45	1.50
120	0.48	0.48	0.60	0.72	0.78	0.84	0.90	0.96	1.02	1.08	1.14	1.20	1.26	1.32	1.30	1.38	1.56	1.68	1.74	1.80
140	0.56	0.56	0.70	0.84	0.91	0.98	1.05	1.12	1.19	1.26	1.33	1.40	1.47	1.54	1.51	1.61	1.82	1.96	2.03	2.10
160	0.64	0.64	0.80	0.96	1.04	1.12	1.20	1.28	1.36	1.44	1.52	1.60	1.68	1.76	1.73	1.84	2.08	2.24	2.32	2.40
180	0.72	0.72	0.90	1.08	1.17	1.26	1.35	1.44	1.53	1.62	1.71	1.80	1.89	1.98	1.94	2.07	2.34	2.52	2.61	2.70

<sup>1</sup>Pipe length baseline temperature = 0°F. "Expansion of Carbon, Copper and Stainless Steel Pipe," *The Engineers' Toolbox*, www.engineeringtoolbox.com.

Figure 28: Coiled Expansion Loops and Offsets (Plan View shown).

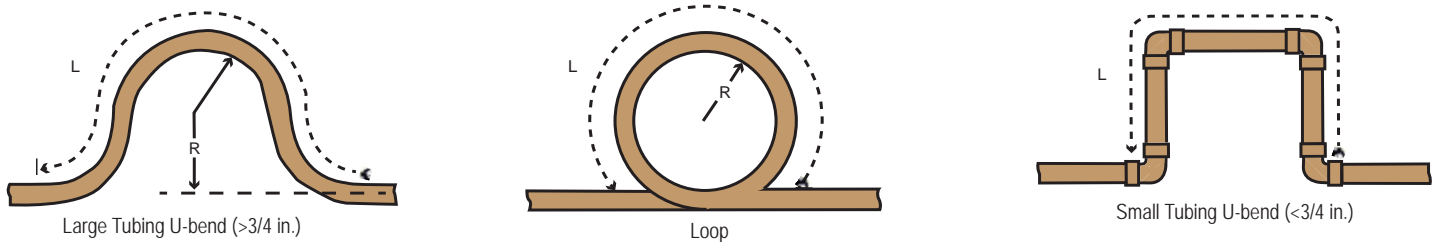

Table 18: Radii of Coiled Expansion Loops and Developed Lengths of Expansion Offsets.

Anticipated Linear Expansion (LE) (inches)		Nominal Tube Size (OD) inches			
		1/4	3/8	1/2	3/4
1/2	R <sup>1</sup>	6	7	8	9
	L <sup>2</sup>	38	44	50	59
1	R <sup>1</sup>	9	10	11	13
	L <sup>2</sup>	54	63	70	83
1-1/2	R <sup>1</sup>	11	12	14	16
	L <sup>2</sup>	66	77	86	101
2	R <sup>1</sup>	12	14	16	19
	L <sup>2</sup>	77	89	99	117
2-1/2	R <sup>1</sup>	14	16	18	21
	L <sup>2</sup>	86	99	111	131
3	R <sup>1</sup>	15	17	19	23
	L <sup>2</sup>	94	109	122	143
3-1/2	R <sup>1</sup>	16	19	21	25
	L <sup>2</sup>	102	117	131	155
4	R <sup>1</sup>	17	20	22	26
	L <sup>2</sup>	109	126	140	166

<sup>1</sup>R = Centerline Length of Pipe.

<sup>2</sup>L = Centerline Minimum Radius (inches).

**Note:**

All expansion Loops and Offsets should be installed in the horizontal plane to prevent the possibility of trapping oil. Loops and Offsets in vertical risers should also be installed in a horizontal plane.



### Note:

LG Electronics U.S.A., Inc., is not responsible for any piping calculations, refrigerant leaks, degradation of performance, or any other potential problems or damages as a result of interconnecting piping, their joint connections, isolation valves, introduced debris inside the piping system, or other problems caused by the interconnecting piping system.

## Pipe Bends

When bending soft copper, use long radius bends. Refer to the "Radii of Coiled Expansion Loops and Developed Lengths of Expansion Offsets" table for minimum radius specifications, page 18.

## In-line Refrigeration Components

Components such as oil traps, solenoid valves, filter-dryers, sight glasses, tee fittings, and other after-market accessories are not permitted on the refrigerant piping system between the outdoor units and the indoor / branch distribution units. Multi F and Multi F MAX systems are provided with redundant systems that assure oil is properly returned to the compressor. Sight-glasses and solenoid valves may cause vapor to form in the liquid stream. Over time, dryers may deteriorate and introduce debris into the system. The designer and installer should verify the refrigerant piping system is free of traps, sagging pipes, sight glasses, filter dryers, etc.

## Field-Provided Isolation Ball Valves

LG maintains a neutral position on using isolation valves in VRF refrigerant piping systems. LG does not endorse any manufacturer of isolation valves. It is recognized that installing isolation valves may simplify future maintenance requirements, and, if used, considerations should be taken including, but not limited to, the following:

- Pressure drops for any component used, including isolation valves, must be known in equivalent pipe length and calculated into the total and segment equivalent piping lengths and compared to product design limitations.
- In all cases, materials must be suitable for the application and any applicable codes, including, but not limited to, diameter and wall thickness continuity per ACR standards.

Failure to do so may cause significant performance degradation. Proper leak checks must be performed. Using isolation valves does not automatically void any LG product warranty; however, a limited warranty may be voided in whole or part should any field supplied accessory fail in any way that causes product failure.

## Using Elbows

Field supplied elbows are allowed as long as they are designed for use with R410A refrigerant. The designer and installer, however, should be cautious with the quantity and size of fittings used, and must account for the additional pressure losses in equivalent pipe length calculation for each branch. The equivalent pipe length of each elbow must be added to each pipe segment in the LATS program. See page 35 for equivalent lengths.

## Pipe Slope

The horizontal pipe slope cannot exceed 10° up or down.

### Inserts and Pipe Supports

#### Inserts

An insert can be installed into a floor or beam before the concrete sets so that fittings such as ducts, pipes, or suspension bolts can be added at a later time. Decide where the inserts should be placed before support installation.

#### Pipe Supports

#### Note:

*A properly installed pipe system should be adequately supported to avoid pipe sagging. Sagging pipes become oil traps that lead to equipment malfunction.*

⊘ Pipe supports should never touch the pipe wall; supports shall be installed outside (around) the primary pipe insulation jacket.

Insulate the pipe first because pipe supports shall be installed outside (around) the primary pipe insulation jacket. Clevis hangers should be used with shields between the hangers and insulation.

Field provided pipe supports should be designed to meet local codes. If allowed by code, use fiber straps or split-ring hangers suspended from the ceiling on all-thread rods (fiber straps or split ring hangers can be used as long as they do not compress the pipe insulation). Place a second layer of insulation over the pipe insulation jacket to prevent chafing and compression of the primary insulation within the confines of the support pipe clamp.

A properly installed pipe system will have sufficient supports to avoid pipes from sagging during the life of the system. As necessary, place supports closer for segments where potential sagging could occur. Maximum spacing of pipe supports shall meet local codes. If local codes do not specify pipe support spacing, pipe shall be supported a maximum of five (5) feet on center for straight segments of pipe up to 3/4" outside diameter size.

Wherever the pipe changes direction, place a hanger within twelve (12) inches on one side and within twelve to nineteen (12 to 19) inches of the bend on the other side. Support piping at indoor units as shown. Support Y-Branch fittings as shown.

Figure 29: Installing an Insert Into a Concrete Beam.

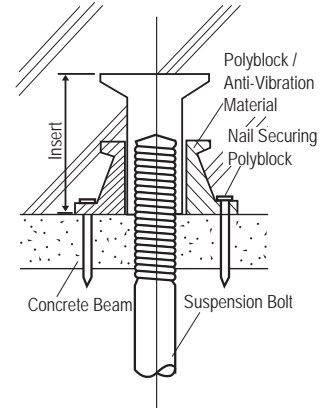

Figure 30: Pipe Hanger Details.

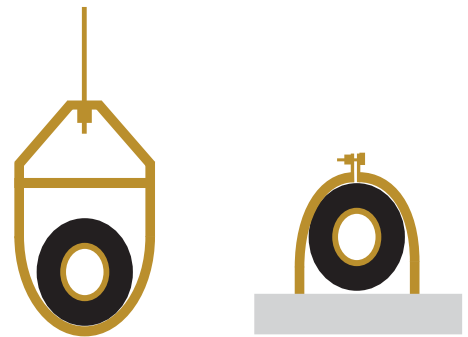

Figure 31: Typical Pipe Support Location—Change in Pipe Direction.

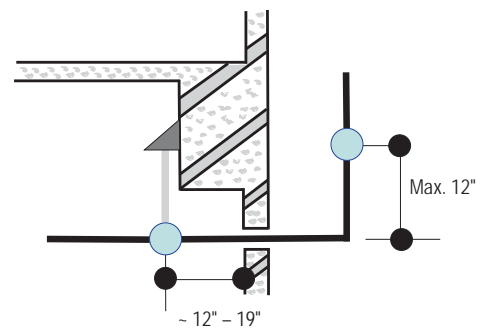

Figure 32: Pipe Support at Indoor Unit.

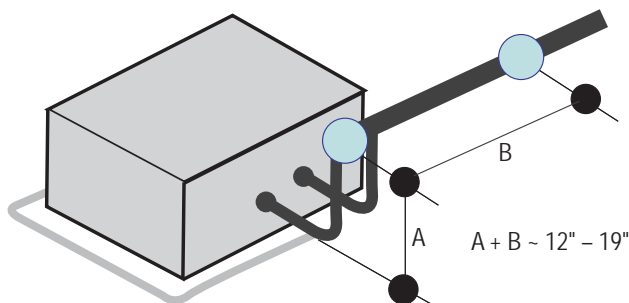
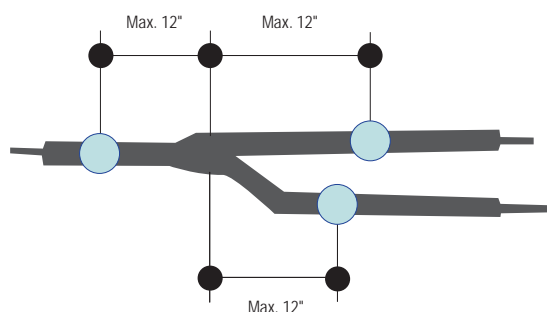

Figure 33: Pipe Support at Y-branch Fitting.



# GENERAL INSTALLATION GUIDELINES

MULTI F  
MULTI F MAX

## Piping Materials and Handling

### Examples of Supports

Figure 34: U-Bolt Support with Insulation.

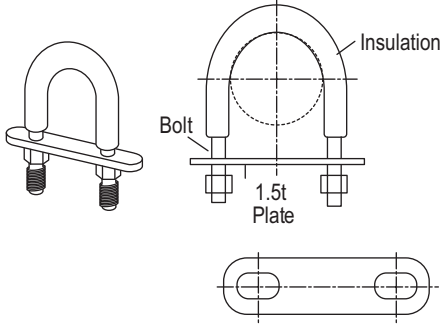

Figure 35: O-Ring Support with Insulation.

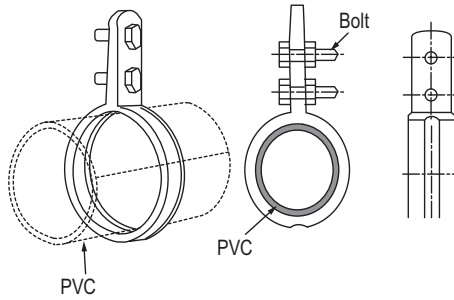
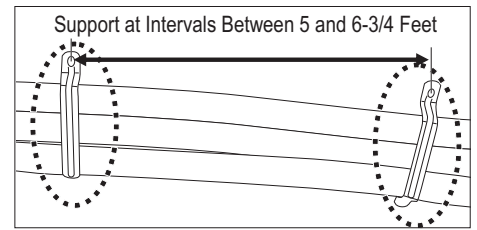

Figure 36: Saddle-Type Support.



*Do not compress the insulation with the saddle-type support. If the insulation is compressed, it may tear open and allow condensation to generate during product operation.*

Figure 37: U-Bolt Support with an Insulated Pipe.

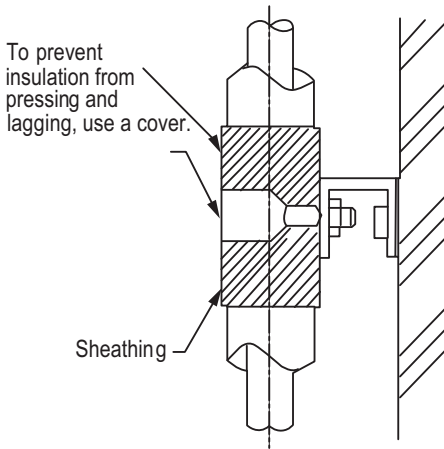

Figure 38: O-Ring Band Support with an Insulated Pipe.

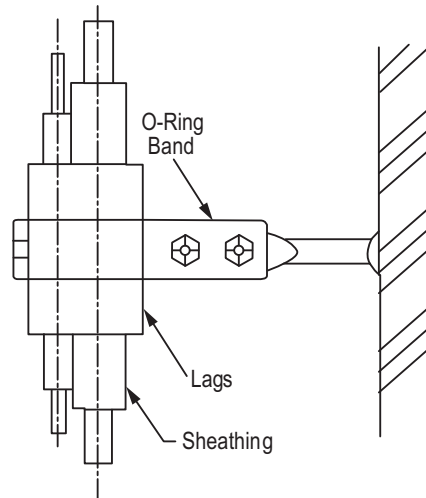

Figure 39: One-Point Down-Stop Support (>441 lbs.).

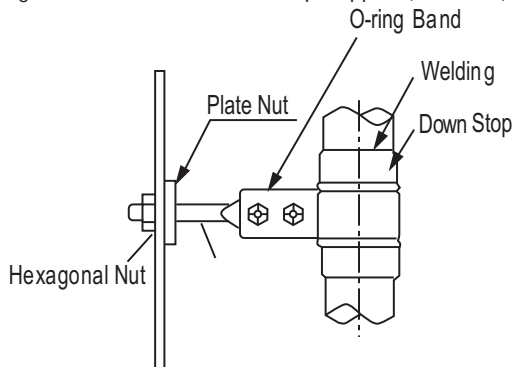
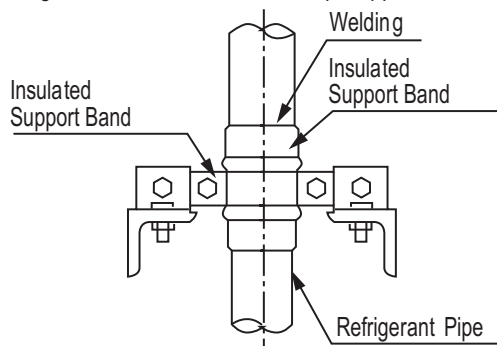

Figure 40: Two-Point Down-Stop Support.



The following are examples of manual pipe size calculations. Designers are highly encouraged to use LATS for Multi F systems.

## Device Connection Limitations

- The minimum number of connected and operating indoor units to Multi F / Multi F MAX systems is two, taking into consideration the minimum combination ratio.
- The maximum number of indoor units for each Multi F / Multi F MAX heat pump systems is:  
 LMU18CHV = 2    LMU24CHV = 3    LMU30CHV = 4    LMU36CHV = 4    LMU480HV = 8    LMU540HV = 8    LMU600HV = 8

### Note:

For allocated capacity information, see the combination tables in the "Multi F / Multi F MAX Combination Data Manual" on [www.lg-dfs.com](http://www.lg-dfs.com). For performance data, see "Multi F / Multi F MAX Performance Data Manual" on [www.lg-dfs.com](http://www.lg-dfs.com).

## Piping Length and Elevation Limitations

One of the most critical elements of Multi F and Multi F MAX systems is the refrigerant piping. The tables on the next few pages list pipe length limits that must be followed in the design of Multi F and Multi F MAX refrigerant pipe systems.

## Using Refrigerant Components

Field-supplied elbows are allowed as long as they are designed for use with R410A refrigerant. The designer, however, should be cautious with the quantity and size of fittings used, and must account for the additional pressure losses in equivalent pipe length calculation for each branch. The equivalent pipe length of each elbow must be added to each pipe segment.

Table 20: Equivalent Piping Length for Elbows, Y-branches, and Branch Distribution Units.

Component	Size (Inches)				
	1/4	3/8	1/2	5/8	3/4
Elbow (ft.)	0.5	0.6	0.7	0.8	1.2
Y-Branch Kit (ft., Multi F MAX systems only) <sup>1</sup>	1.6				
Branch Distribution Unit (ft., Multi F MAX systems only)	8.2				

<sup>1</sup>Kit contains two Y-branches: one for liquid and one for vapor.

## Multi F Outdoor Unit Piping Length and Elevation Limitations

Table 19: Multi F Refrigerant Piping System Limitations.

Outdoor Unit Model (Btu/h)	LMU18CHV / 18,000	LMU24CHV / 24,000	LMU30CHV / 30,000	LMU36CHV / 36,000
Max. Total System Piping Length (ft.)	164 A+B	246.1 A+B+C	246.1 A+B+C+D	246.1 A+B+C+D
Min. Length for One Branch (ft.)	9.8	9.8	9.8	9.8
Max. Length for One Branch (ft.)	82	82	82	82
Max. Elevation Between Each Indoor Unit and Outdoor Unit (h1)	49.2	49.2	49.2	49.2
Max. Elevation Between Indoor Units (h2)	24.6	24.6	24.6	24.6
Max. Combination of Indoor Units	24,000	33,000	40,000	48,000

Figure 41: Multi F Refrigerant Piping System Limitations (LMU18CHV Example).

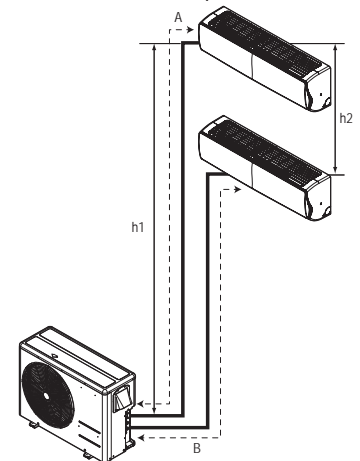

## Multi F System Example

Example: LMU36CHV outdoor unit with four (4) indoor units connected.

ODU: Outdoor Unit.

IDU: Indoor Unit.

A, B, C, D: Pipes from Outdoor Unit to Indoor Unit.

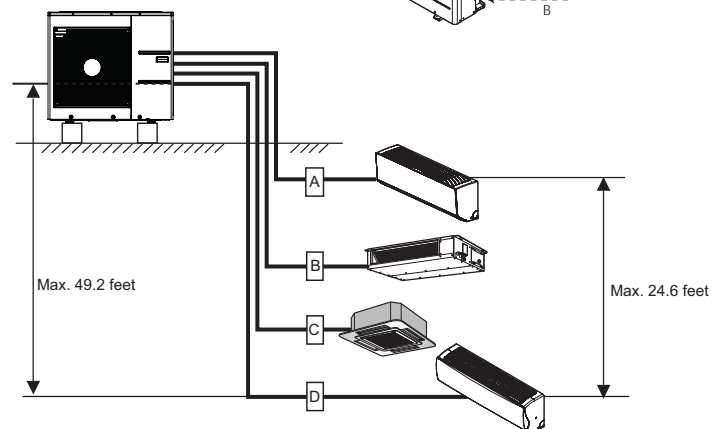

# REFRIGERANT PIPING CONNECTIONS

MULTI F  
MULTI F MAX

The following are examples of manual pipe size calculations. Designers are highly encouraged to use LATS for Multi F systems.

## Multi F MAX Outdoor Unit Piping Length and Elevation Limitations

Table 22: Multi F MAX Refrigerant Piping System Limitations.

Pipe Length (ELF = Equivalent Length of pipe in Feet)	<b>Total piping length (<math>\Sigma A + \Sigma B</math>)</b>		$\leq 475.7$ feet
	Main pipe (Outdoor Unit to Branch Distribution Units: $\Sigma A$ )	Minimum	9.8 feet
		Maximum	$\leq 180.4$ feet
	<b>Total branch piping length (<math>\Sigma B</math>)</b>		$\leq 295.3$ feet
	Branch pipe (Branch Distribution Units to Indoor Units: B)	Minimum	10 feet
Maximum		$\leq 49.2$ feet	
Elevation Differential (All Elevation Limitations are Measured in Actual Feet)	If outdoor unit is above or below indoor unit ( $h_1$ )		$\leq 98.4$ feet
	Between the farthest two indoor units ( $h_2$ )		$\leq 49.2$ feet
	Between branch distribution unit and farthest connected indoor unit(s) ( $h_3$ )		$\leq 32.8$ feet
	Between branch distribution units ( $h_4$ )		$\leq 49.2$ feet
Max. Combination of IDUs	LMU480HV = 65,000	LMU540HV = 73,000	LMU600HV = 81,000

Figure 42: Multi F MAX Refrigerant Piping System Limitations.

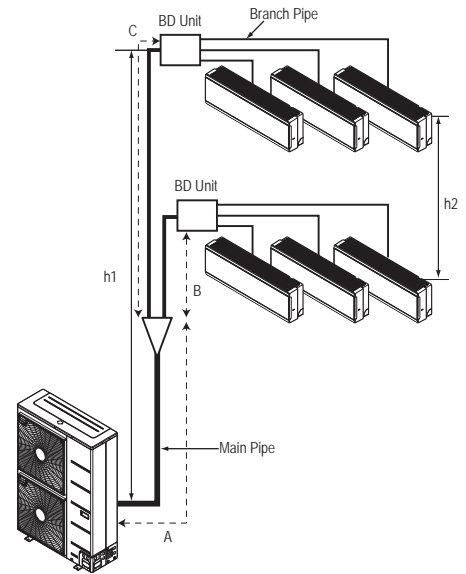

Table 23: Multi F MAX Piping Sizes.

Piping	Main Pipe A (inch)	Branch Pipe B
Liquid	$\varnothing 3/8$	Depends on the size of the indoor unit piping
Gas	$\varnothing 3/4$	

## Multi F MAX System Example with One Branch Distribution Unit

Example: LMU540HV outdoor unit with four (4) indoor units, and one (1) branch distribution unit connected.

ODU: Outdoor Unit.

IDU: Indoor Unit.

BDU: Branch Distribution Unit.

A: Main Pipe.

B: Branch Pipe (Branch Distribution Unit to Indoor Unit[s]).

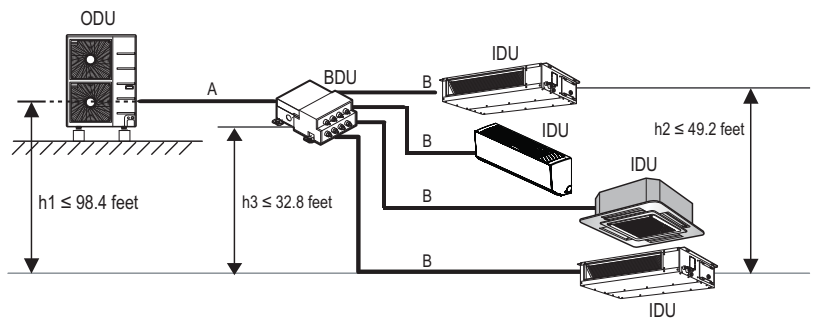

## Multi F MAX System Example with Two Branch Distribution Units

Example: LMU540HV outdoor unit with seven (7) indoor units, and two (2) branch distribution units connected.

ODU: Outdoor Unit.

IDU: Indoor Unit.

BD: Branch Distribution Unit(s).

$\Sigma A$ : Main Pipe.

$\Sigma B$ : Branch Pipe (Branch Distribution Unit[s] to Indoor Unit[s]).

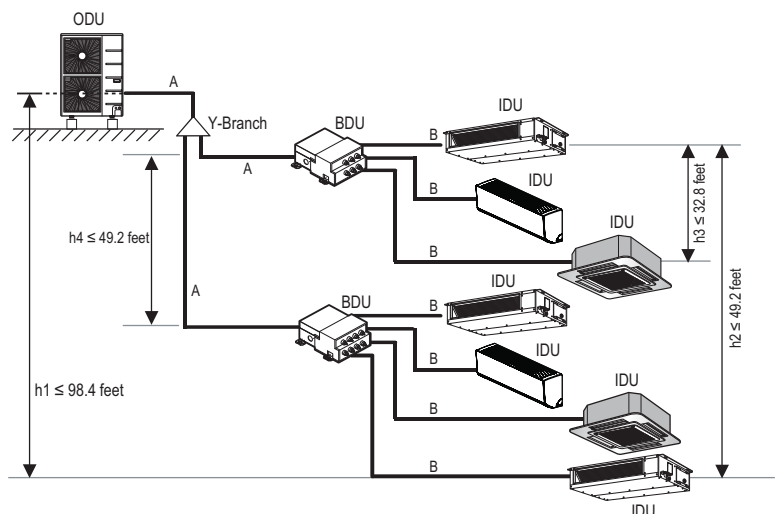

MULTI F / MULTI F MAX Outdoor Unit Installation Manual

## Multi F Outdoor Unit to Indoor Unit Piping Connections

### Note:

#### Avoid Pipe Damage

- When routing field-provided piping, avoid damaging the outdoor unit from excessive vibration.
- Properly insulate the liquid and gas lines separately up to the point of connection at the unit frame.
- See table below for Multi F outdoor unit connection types.

⊘ Correctly route the piping so it does not make contact with mounting bolts. Allow room for field installation.

Table 24: Outdoor Unit Piping Connections.

Outdoor Unit Piping Connections	LMU18CHV	LMU24CHV	LMU30CHV	LMU36CHV
Liquid Line Connection (in., OD) x Qty.	1/4 x 2	1/4 x 3	1/4 x 4	1/4 x 4
Vapor Line Connection (in., OD) x Qty.	3/8 x 2	3/8 x 3	3/8 x 4	3/8 x 4

Table 25: Indoor Unit Pipe Sizes.

Indoor Unit Capacity	Vapor Line Piping Size (in., OD)	Liquid Line Piping Size (in., OD)
7,000 Btu/h	Ø3/8	Ø1/4
9,000 Btu/h		
12,000 Btu/h		
15,000 Btu/h		
18,000 Btu/h	Ø1/2	
24,000 Btu/h		

Connection sockets (included as a factory-supplied accessory with the indoor units) may need to be used when piping the indoor units to the outdoor unit. If a 36K indoor unit is included, the connection sockets are included with the Branch Distribution unit.

Table 26: Connection Socket Dimensions.

Indoor Unit Capacity	Vapor (in., OD)		Liquid (in., OD)	
	A	B	A	B
18,000 Btu/h: Wall-Mounted	Ø3/8 → Ø1/2, Ø1/2 → Ø5/8		Ø1/4 → Ø3/8	
18,000 Btu/h: Low Static Duct, Four-Way Cassette	Ø3/8 → Ø1/2		N/A	
24,000 Btu/h	Ø3/8 → Ø1/2		N/A	

### Using the Connection Socket

1. Align the center of the piping sections and tighten the flare nut by hand.
2. Tighten the flare nut with a torque wrench, using the arrows on the wrench as a guide, until a click is heard.

Figure 43: Multi F Refrigerant Pipe Connections (LMU36CHV shown as example).

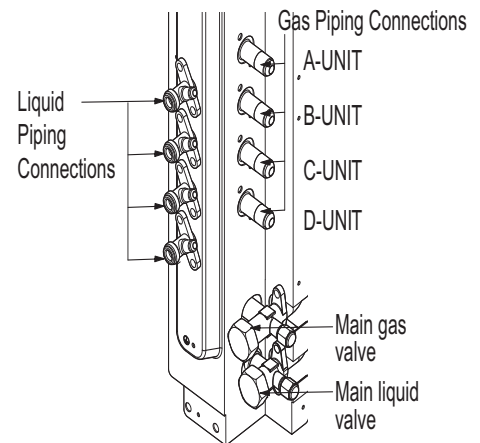

Table 27: Indoor Unit Piping Connections.

Indoor Unit Capacity	Vapor Line Conn. (in., OD)	Liquid Line Conn. (in., OD)
7,000 Btu/h	Ø3/8	Ø1/4
9,000 Btu/h		
12,000 Btu/h		
15,000 Btu/h		
18,000 Btu/h: Wall-Mounted	Ø5/8	Ø3/8
18,000 Btu/h: Low Static Duct, Four-Way Cassette	Ø1/2	Ø1/4
24,000 Btu/h	Ø1/2	Ø1/4

Figure 44: Connection Socket Diagram.

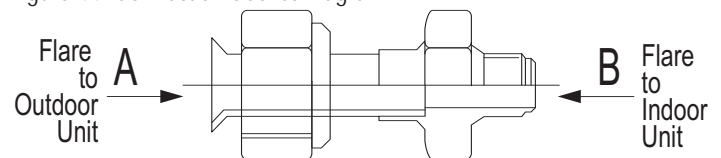
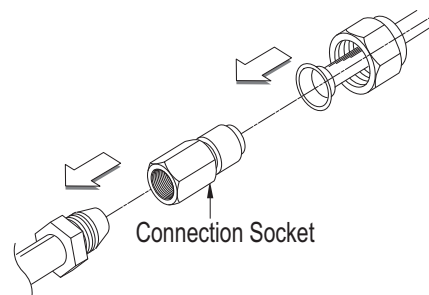

Figure 45: Performing Connections.



## Multi F MAX Outdoor Unit System Piping Connections

### Note:

#### Avoid Pipe Damage

- When routing field-provided piping, avoid damaging the outdoor unit from excessive vibration.
- Properly insulate the liquid and gas lines separately up to the point of connection at the unit frame.
- See table below for Multi F MAX outdoor unit connection types.

⊘ Correctly route the piping so it does not make contact with mounting bolts. Allow room for field installation.

#### Branch Distribution to Indoor Unit Piping Connections

- Install indoor unit liquid and vapor refrigerant pipes (and connection wiring) to the appropriate branch distribution ports.
- Clearly note on the indoor unit's refrigerant piping (liquid, vapor) which branch distribution port it is connected to (A, B, C, D).

Table 29: Branch Distribution Unit Piping Connections.

Branch Distribution Unit	PMBD3620	PMBD3630	PMBD3640	PMBD3641
<b>Piping Connections to Outdoor Unit</b>				
Liquid (in., OD) x Qty.	Ø3/8 x 1			
Vapor (in., OD) x Qty.	Ø3/4 x 1			
<b>Piping Connections to Indoor Units</b>				
Liquid (in., OD) x Qty.	Ø1/4 x 2	Ø1/4 x 3	Ø1/4 x 4	Ø1/4 x 4
Vapor (in., OD) x Qty.	Ø3/8 x 2	Ø3/8 x 3	Ø3/8 x 4	Ø3/8 x 3, Ø1/2 x 1

Table 30: Indoor Unit Pipe Sizes.

Indoor Unit Capacity	Vapor Line Piping Size (in., OD)	Liquid Line Piping Size (in., OD)
7,000 Btu/h	Ø3/8	Ø1/4
9,000 Btu/h		
12,000 Btu/h		
15,000 Btu/h		
18,000 Btu/h	Ø1/2	Ø3/8
24,000 Btu/h		
36,000 Btu/h	Ø5/8	Ø3/8

Connection sockets (included as a factory-supplied accessory with the indoor units) may need to be used when piping the indoor units to the branch distribution unit. If a 36K indoor unit is included, the connection sockets are included with the Branch Distribution unit.

Table 32: Connection Socket Dimensions.

Indoor Unit Capacity	Vapor (in., OD)		Liquid (in., OD)	
	A	B	A	B
18,000 Btu/h: Wall-Mounted	Ø3/8 → Ø1/2, Ø1/2 → Ø5/8		Ø1/4 → Ø3/8	
18,000 Btu/h: Low Static Duct, Four-Way Cassette	Ø3/8 → Ø1/2		N/A	
24,000 Btu/h	Ø3/8 → Ø1/2		N/A	
36,000 Btu/h	Ø1/2 → Ø5/8		Ø1/4 → Ø3/8	

Table 28: Outdoor Unit Piping Connections.

Outdoor Unit Piping Connections	LMU480HV, LMU540HV, LMU600HV
Liquid Line Connection (in., OD) x Qty.	3/8 x 1
Vapor Line Connection (in., OD) x Qty.	3/4 x 1

Figure 46: Branch Distribution Ports to Indoor Units.

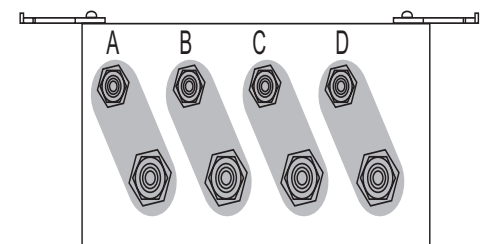
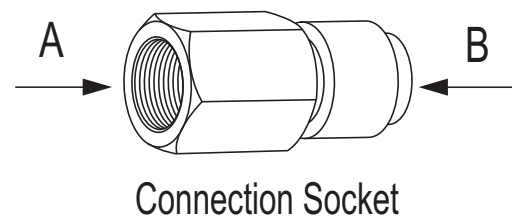

Table 31: Indoor Unit Piping Connections.

Indoor Unit Capacity	Vapor Line Conn. (in., OD)	Liquid Line Conn. (in., OD)
7,000 Btu/h	Ø3/8	Ø1/4
9,000 Btu/h		
12,000 Btu/h		
15,000 Btu/h		
18,000 Btu/h: Wall-Mounted	Ø5/8	Ø3/8
18,000 Btu/h: Low Static Duct, Four-Way Cassette	Ø1/2	Ø1/4
24,000 Btu/h	Ø1/2	Ø1/4
36,000 Btu/h	Ø5/8	Ø3/8

Figure 47: Connection Socket Diagram.



## Multi F MAX Outdoor Unit System Piping Connections, continued.

1. Align the center of the piping sections and tighten the flare nut by hand.
2. Tighten the flare nut with a torque wrench, using the arrows on the wrench as a guide, until a click is heard.
3. Wrap insulation around the connection.

Figure 48: Possible Outdoor Unit or Branch Distribution Unit to Indoor Unit Connections.

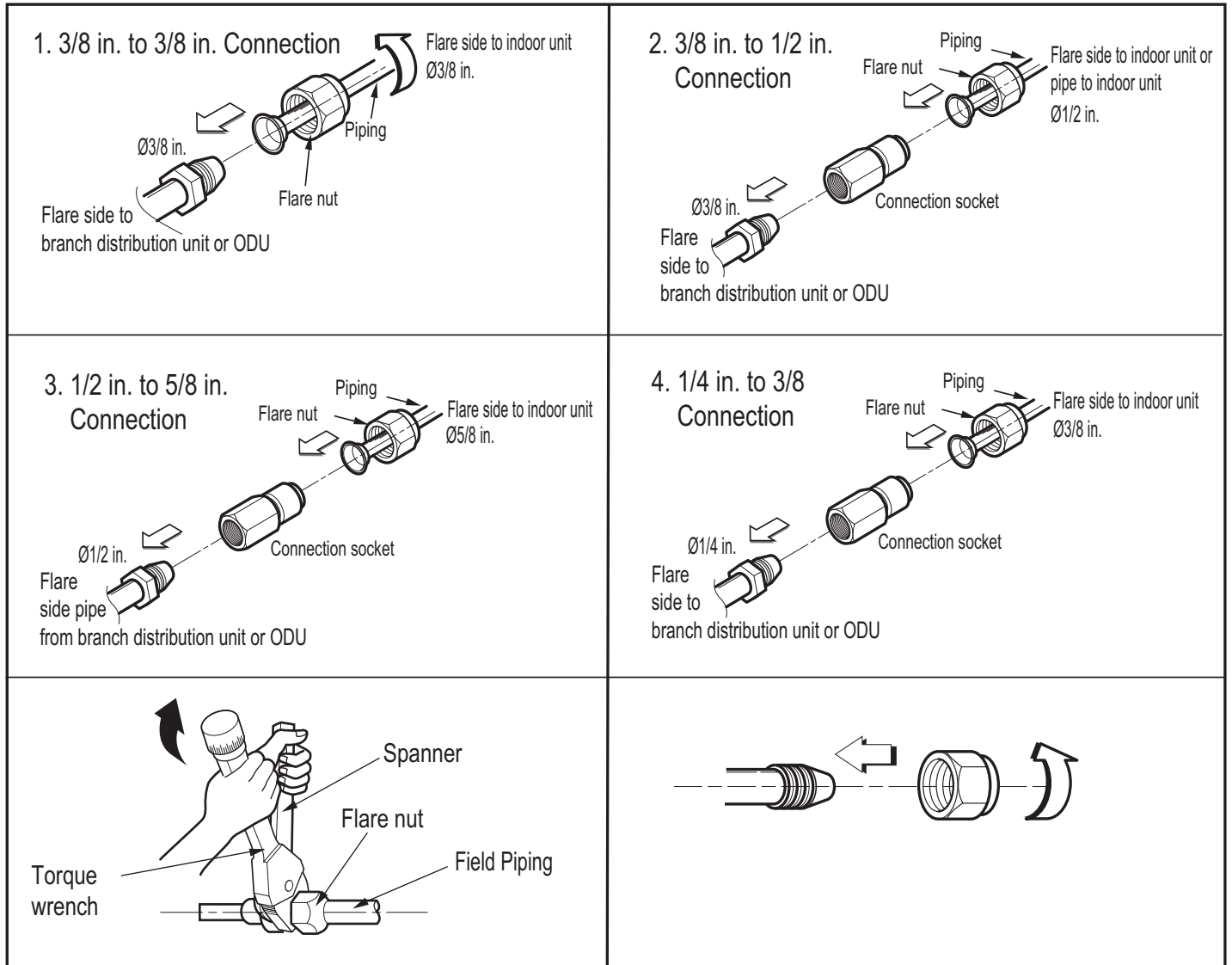

## Outdoor Unit Condensate Drain Piping

Outdoor unit requires condensate drain piping. Condensate drain pipe is constructed with materials approved by local code. See pages 13 to 17 for information in reference to outdoor unit placement and condensate drainage.

# REFRIGERANT PIPING CONNECTIONS

MULTI F  
MULTI F MAX

## Y-Branch Kit

### Multi F MAX Y-Branch Kit PMBL5620

Y-branches may be installed in horizontal or vertical configurations. When installed vertically, position the Y-branch so the straight-through leg is  $\pm 3^\circ$  of plumb. When installed horizontally, position the Y-branch so the take-off leg is level and shares the same horizontal plane as the straight-through leg  $\pm 5^\circ$  rotation.

Y-branches should always be installed with the single port facing the outdoor unit and the two-port end facing the branch distribution units.

The equivalent pipe length of each Y-branch (1.6') must be added to the main pipe segment entered into LATS Multi F piping design software.

Figure 50: Horizontal Configuration End View.

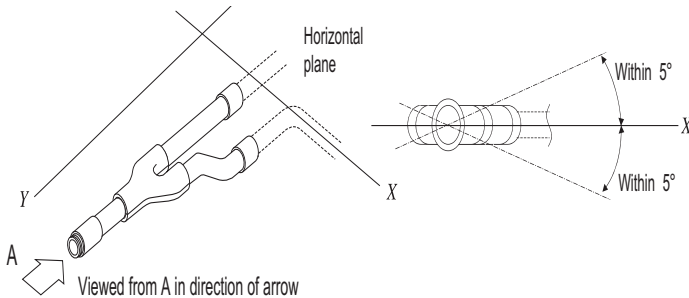

Table 33: Y-Branch Connection Diameters.

Model	Y-Branch Type	Port Identifier (inch)			Dimensions	
		1	2	3	X	Y
PMBL5620	Liquid	3/8	3/8	3/8	13.80	3.24
	Vapor	3/4	3/4	3/4	12.48	3.02

Figure 49: Y-Branch Port Identifier Diagram.



Figure 51: Y-Branch Dimensions Diagram.

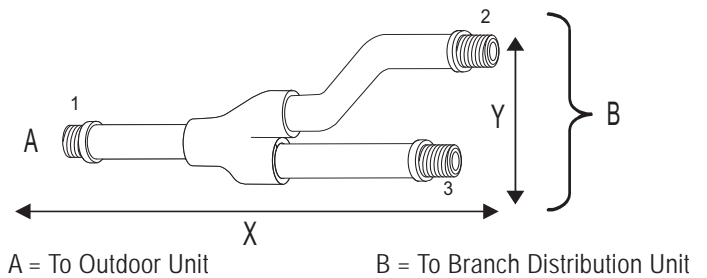
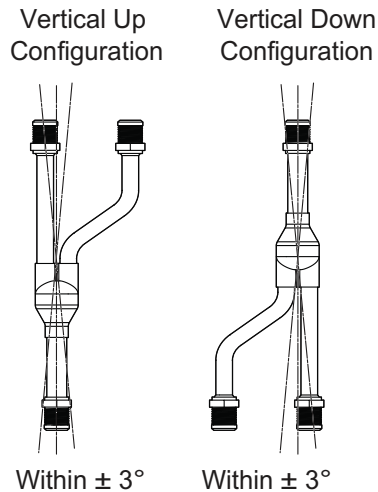

Figure 52: Y-branch Installation Alignment Specification.



### Flushing the Refrigerant Piping

Flushing is a method of cleaning the refrigerant piping using pressurized nitrogen gas. Flushing:

1. Removes oxidation bubbles that may have formed inside the copper piping if nitrogen replacement was insufficient during soldering.
2. Removes foreign material and moisture from piping if the piping wasn't stored properly.
3. Checks connections in pipes linking outdoor and indoor units (both liquid and gas pipes).

### Flushing the Refrigerant Piping Procedure

1. Attach a pressure regulator on a nitrogen cylinder.
2. Connect the charge hose from the pressure regulator to the outdoor unit liquid piping side service port before its connection to the indoor or BD (Multi F MAX systems only) unit piping.
3. Open the main valve on the nitrogen cylinder and set the pressure regulator to 0.5 MPa (72.5 psi).
4. Verify that the nitrogen is flowing through the piping correctly.
5. When flushing, block the open end of the piping with a wood insulation block. When the pressure becomes too high, quickly remove the block.
6. Repeat steps 4 and 5 until the piping is completely flushed and clean.
7. Connect the charge hose from the pressure regulator to the outdoor unit gas piping side service port before its connection to the indoor or BD (Multi F MAX systems only) unit piping.
8. Follow steps 3, 4, 5, and 6.
9. For systems with BD unit(s) (Multi F MAX only), each piping run should be flushed individually before connecting the indoor units (follow steps 3, 4, 5, and 6).

### Note:

Nitrogen flushing is strongly recommended after soldering. Foreign materials in the piping will cause system malfunction.

Figure 53: Flushing the Refrigerant Piping.

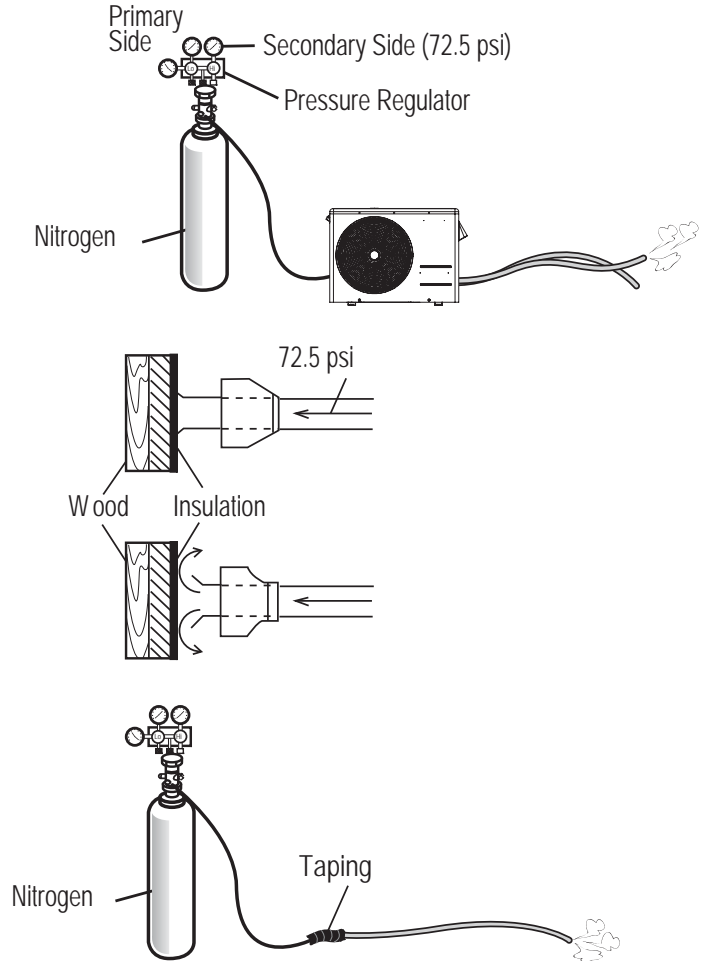

### Leak Test and Vacuum Procedures

Before performing the test run, Multi F and Multi F MAX refrigerant piping and the piping connections to the outdoor unit, the indoor units, and the BD units (Multi F MAX systems only) must be evacuated to remove any non-condensable gases and moisture that may be present in the system, and checked for leaks. Air and moisture that is left in the piping can lead to undesirable results and can cause damage to the working unit. It is important to go through a complete air purging cycle to be sure that the lines are cleared out. Note that this process may have to be repeated should any air or moisture be found to remain in the piping. After air purging and evacuating the lines, be sure to take a leak test for all piping and tubing. If any air and moisture remain in the refrigerant system:

1. Pressure in the system rises.
2. Operating current rises.
3. Cooling or heating efficiency drops.
4. Moisture in the refrigerant circuit may freeze and block capillary tubing.
5. Water may corrode parts of the refrigeration system.

### Leak Test

#### Note:

Perform the leak test by pressurizing nitrogen gas to 550 psi on both the liquid and gas pipes. Test with the piping service valves closed. If the pressure does not drop for twenty-four (24) hours, the system passes the test. If the pressure drops, there is a nitrogen leak in the system. Find the leak, repair, and then test again.

#### Before the Leak Test

1. Check that all refrigerant piping, the drain pipe, and power wiring / communications cables are properly connected.
2. Remove the caps from both the gas and the liquid service valves on the outdoor unit. Verify that both service valves are closed.

#### Pressure Gauge Hookup

3. Connect the manifold valve (which includes the pressure gauges), along with the dry nitrogen gas cylinder, to the service valves using the charge hoses.

#### Note:

Use a manifold valve for leak testing. The high side manifold valve must always be kept closed.

#### Leak Test Procedure

4. Pressurize the system to maximum 550 psig with the dry nitrogen gas.

#### ⚠ DANGER

Use of combustible gases including oxygen, may result in fire or explosion, resulting in personal injury or death.

#### ⚠ WARNING

Use of combustible gases including oxygen runs the risk of fire and explosion, resulting in personal injury or death. Inert gas (nitrogen) should be used when checking leaks, cleaning or repairs of pipes, etc.

#### Note:

- To avoid nitrogen entering the refrigerant system in a liquid state, the top of the cylinder must be higher than its bottom when the system is pressurized.
- The cylinder should be used in a vertical standing position.

5. Close the cylinder valve when the gauge reading reaches 550 psig, and then test for leaks using the liquid soap method.
6. While running the nitrogen gas tank hookup, apply a soap water or a liquid neutral detergent to all indoor, BD, outdoor unit connection(s), and all refrigerant piping joints with a soft brush. Also test for leaks at both of the gas and liquid side service valves.

Figure 54: Leak Test Diagram.

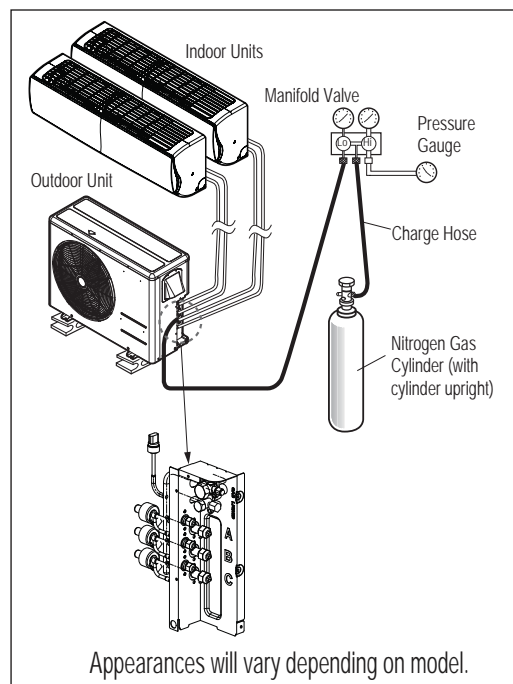

## Leak Test Procedure, continued.

7. While operating the pressure gauge system, observe the connections for any leaks. If bubbles appear at any of the connections (indoor, BD, and outdoor units) or refrigerant piping joints, a leak is present.
8. Make a note of where the leaks are, and remove the soap with a clean cloth.
9. Disengage the nitrogen pressure by loosening the charge hose connector at the nitrogen cylinder. After the system pressure is back to normal range, disconnect hose from the cylinder.
10. Repair the connections and piping where bubbles / leaks were observed. When finished, repeat leak testing using the liquid soap method and nitrogen cylinder.
11. After system is leak free, depressurize by loosening the charge hose connector at the nitrogen cylinder. When system pressure returns to normal, disconnect the hose from the cylinder.

## Essential Points for Leak Testing

The key to successful testing is strict adherence to the leak testing procedure.

1. The liquid and gas piping in each refrigerant system should be pressurized with nitrogen gas in accordance with the steps listed below.
  - Step 1: Pressurize to 43.5 psi for three (3) minutes or more. (Will identify if major leaks are present in the system.)
  - Step 2: Pressurize to 217.6 psi for three (3) minutes or more. (Will identify if major leaks are present in the system.)
  - Step 3: Pressurize to 551.1 psi for approximate twenty-four (24) hours. (Will identify if minor leaks are present in the system.)

Pressurizing the system to 551.1 psi does not guarantee the identification of minor leaks if the pressure is maintained for only a short time. It is recommended that the system remain pressurized for at least 24 hours.

### Note:

*Piping system should not be pressured to more than 551.1 psi. Pressures greater than 551.1 psi may damage the piping system and cause unit malfunction.*

2. Check for pressure drop. If there is no drop in pressure, the test is successful. If the pressure drops, there is a leak in the piping system. If, however, there was a change in the ambient temperature between when pressure was initialized and when pressure drop is checked, then calculations must be adjusted accordingly. A difference of 1.8°F can account for a pressure change of 1.45 psi.

Compensation Value: Temperature at Pressure Initialization – Temperature at Pressure Check × 1.45

### Example:

During Leak Test: 551.1 psi at 77°F

Twenty-four (24) Hours Later: 543.9 psi at 68°F

Although the pressure dropped from 551.1 psi to 543.9 psi, it can be assumed that there are no leaks because pressure can also drop due to the change in outdoor temperature.

Figure 55: Leak Test Time Diagram.

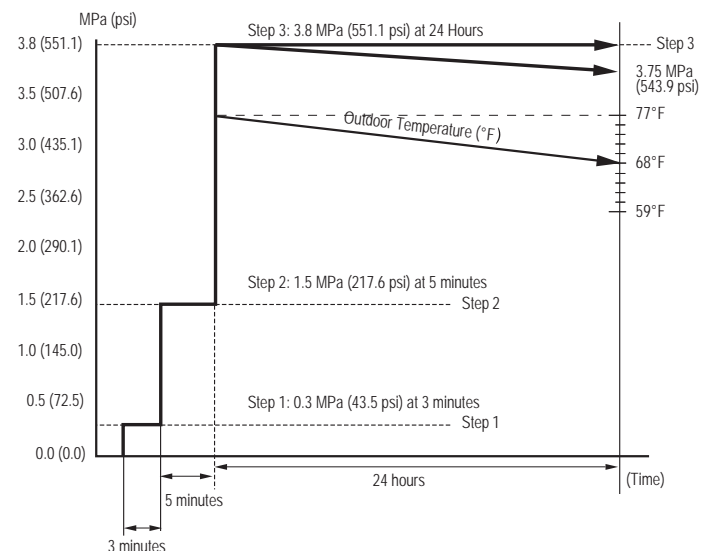

## Vacuum Procedure

### Vacuum Procedure

Vacuum drying should be performed from the service port provided on the outdoor unit's service valve to the vacuum pump commonly used for liquid pipe and the vapor pipe. Vacuum of the pipe and the indoor units should be made from the port of the outdoor unit's service valve with the service valve closed.

#### Note:

-  Never perform air purging using refrigerant; it will damage the outdoor unit.
- Use a vacuum pump that can evacuate to 500 microns.

1. Evacuate the system from the liquid and vapor pipes with a vacuum pump for over two (2) hours and bring the system to 500 microns.
2. Maintain system under that condition for over one (1) hour; if the vacuum gauge rises, the system may contain moisture or a leak.
3. If there is a possibility of moisture in the piping (rainwater may have entered the piping if work was performed during a rainy season or over an extended period), then:
  - Evacuate the system for two (2) hours to 7.3 psi (vacuum break) with nitrogen gas.
  - Evacuate it again with the vacuum pump for one (1) hour to 500 microns (vacuum drying).
4. If the system cannot be evacuated to 500 microns, repeat the steps of vacuum break and drying.
5. Finally, after maintaining the system in vacuum for one (1) hour, check if the vacuum gauge rises or not.

Figure 56: Vacuum Procedure Diagram.

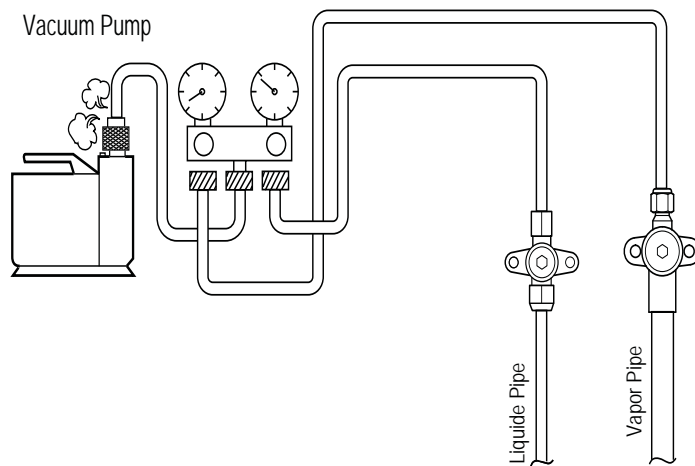

#### Note:

- If the primary refrigerant charge is not performed in a reasonable time after the vacuum procedure is complete, wet air may infiltrate the outdoor unit. If wet air is mixed with refrigerant, the refrigerant cycle may malfunction and the unit may be damaged.
-  Do not perform refrigerant charge while the compressor is operating, otherwise, liquid may leak and subsequently damage the compressor.
- Use a micron gauge to measure vacuum.
- Obtain the precise amount of refrigerant needed using calculations outlined in the following pages. Too much or too little refrigerant may cause the system to malfunction.
- If other refrigerants are mixed in the original refrigerant, the refrigerant piping system may be damaged or malfunction.
- Because R410A is a mixed refrigerant, the required additional refrigerant must be charged in its liquid state. If the refrigerant is charged in its gaseous state, its composition changes and the system will not work properly.

LG Multi F and Multi F MAX outdoor units ship from the factory with a charge of R410A refrigerant. A trim charge may need to be added to take into account additional piping length.

To determine the additional refrigerant that is needed, apply the formulas below, and record the results. If the total additional refrigerant charge value is a negative number, then an additional trim charge does not need to be added to the system.

### Multi F Systems

$$\begin{aligned} \text{Additional charge (lbs.)} &= (\text{Installed Length of Branch [A]} - \text{Chargeless Pipe Length [L]}) \times a \\ &+ (\text{Installed Length of Branch [B]} - \text{Chargeless Pipe Length [L]}) \times a \\ &+ (\text{Installed Length of Branch [C]} - \text{Chargeless Pipe Length [L]}) \times a \\ &+ (\text{Installed Length of Branch [D]} - \text{Chargeless Pipe Length [L]}) \times a \\ &- \text{CF (Correction Factor)} \times 5.29 \end{aligned}$$

#### Note:

- Number of installed length of branches depends on the specifications of the outdoor unit model.
- CF = Maximum number of connectible indoor units – Total number of connected indoor units.

Table 35: Multi F Outdoor Unit Piping Specifications.

Outdoor Unit Model	Min. to Max. Piping Length for One Branch (ft.)	Max. Total System Piping Length (ft.)	Chargeless Pipe Length per Branch (L) (ft.)	Piping Length (No Additional Refrigerant [ft])	Additional Charge Needed (a) (oz./ft.)
LMU18CHV	9.8 to 82	164	24.6	49.2	0.22
LMU24CHV	9.8 to 82	246.1	24.6	73.8	0.22
LMU30CHV	9.8 to 82	246.1	24.6	98.4	0.22
LMU36CHV	9.8 to 82	246.1	24.6	98.4	0.22

Figure 57: Multi F Additional Refrigerant Charge Example.

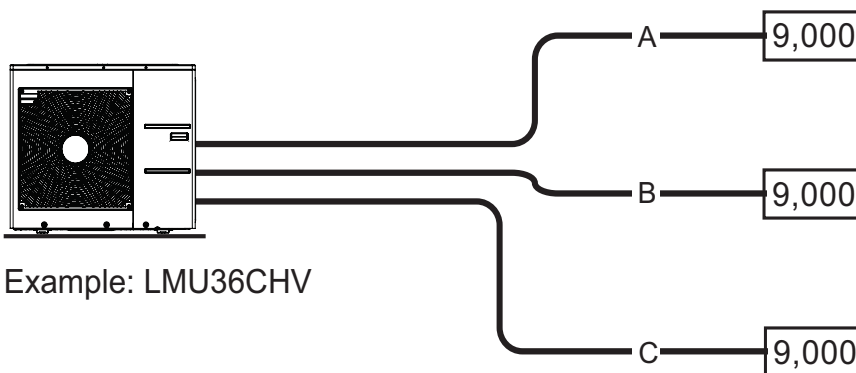

Example: LMU36CHV

Each branch pipe  
A = 82 ft.  
B = 16 ft.  
C = 49 ft.

$$\begin{aligned} \text{Additional Charge} &= (82 - 24.6) \times 0.22 \\ &+ (16 - 24.6) \times 0.22 \\ &+ (49 - 24.6) \times 0.22 \\ &- (4 - 3) \times 5.29 \\ &= 10.82 \text{ oz.} \end{aligned}$$

# REFRIGERANT PIPING PREPARATION

MULTI F  
MULTI F MAX

## Refrigerant Charge

### Multi F MAX Systems

Additional charge (lbs.) = (Total Main Piping Length [A] - Chargeless Pipe Length of Main Pipe [L]) x a  
 + (Installed Length of Branch [B1] - Chargeless Pipe Length [B]) x b  
 + (Installed Length of Branch [B2] - Chargeless Pipe Length [B]) x b  
 + (Installed Length of Branch [B3] - Chargeless Pipe Length [B]) x b ...  
 - CF (Correction Factor) x 3.53

#### Note:

- Number of installed length of branches depends on system specifications.
- CF = Maximum number of connectible indoor units - Total number of connected indoor units

Table 36: Multi F MAX Outdoor Unit Piping Specifications.

Outdoor Unit Model	Main Piping Length		Branch Piping Length	
	Chargeless Pipe Length of Main Pipe (L) (ft.)	Additional Charge Needed (a) (oz./ft.)	Chargeless Pipe Length per Branch Pipe (B) (ft.)	Additional Charge Needed (b) (oz./ft.)
LMU480HV	16.4	0.54	16.4	0.22
LMU540HV	16.4	0.54	16.4	0.22
LMU600HV	16.4	0.54	16.4	0.22

Figure 58: Multi F MAX Additional Refrigerant Charge Example.

LMU540HV

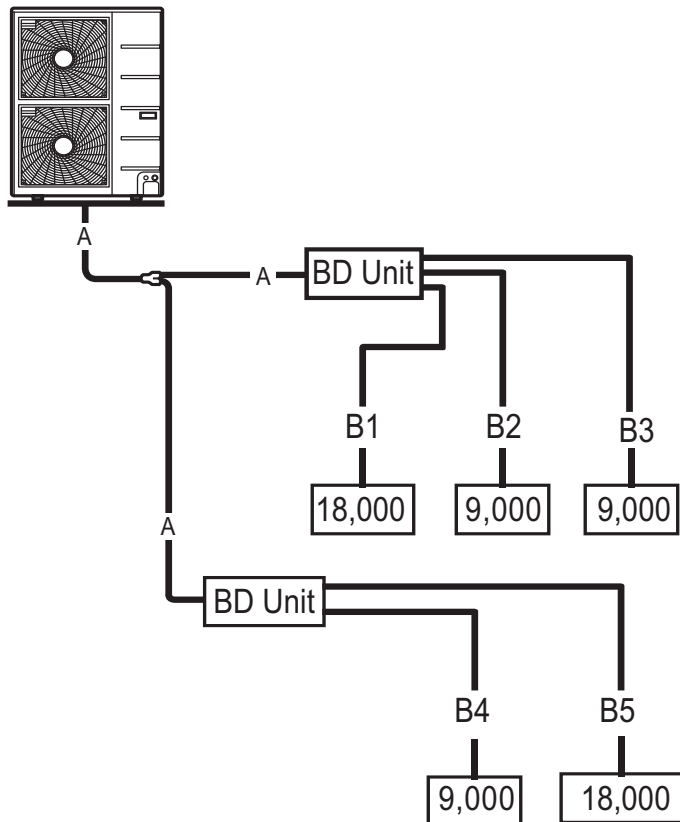

- Total main pipe (A) = 60 ft.
- Each branch pipe  
 B1 = 49 ft.  
 B2 = 17 ft.  
 B3 = 17 ft.  
 B4 = 10 ft.  
 B5 = 23 ft.

$$\begin{aligned}
 \text{Additional Charge} &= (60 - 16.4) \times 0.54 \\
 &+ (49 - 16.4) \times 0.22 \\
 &+ (17 - 16.4) \times 0.22 \\
 &+ (17 - 16.4) \times 0.22 \\
 &+ (10 - 16.4) \times 0.22 \\
 &+ (23 - 16.4) \times 0.22 \\
 &- (8 - 5) \times 3.53 \\
 &= 20.43 \text{ oz.}
 \end{aligned}$$

### Charging the Refrigerant

1. Determine the refrigerant that is needed, applying the necessary formulas as outlined in the previous pages.
2. Connect the charging cylinder to the charge hose on the manifold valve.
3. Purge air from the charge hose by opening the valve at the bottom of the cylinder, and press the check valve on the manifold valve.
4. Confirm that the "Lo" knob of the manifold valve is open and charge the system with liquid refrigerant. (Because R-410A is a non-azeotropic refrigerant, it must be charged in the liquid state.)
  - If the required amount of refrigerant cannot be charged all at once, the refrigerant can be charged a little at a time (approximately 5.29 ounces) while the system operates in cooling. This procedure must be repeated until the entire amount of refrigerant gets charged into the system; perform once, then wait approximately one [1] minute before resuming.
5. Immediately disconnect the charge hose from the service port on the three-way valve. Stopping halfway allows the refrigerant to discharge.
  - If the system has been charged with liquid refrigerant while it operates, turn the system off before disconnecting the hose.
6. Mount the valve stem nuts and the service port nut. Use torque wrench to tighten the service port nut to a torque of 1.8 kg.m and check for leaks.

### ⚠ WARNING

When installing or relocating the outdoor unit, make sure that no substance other than the specified refrigerant (R410A) enters the refrigerant circuit. Any presences of foreign substances such as air can cause an abnormal pressure rise and may result in explosion and physical injury.

Figure 59: Charging the Refrigerant.

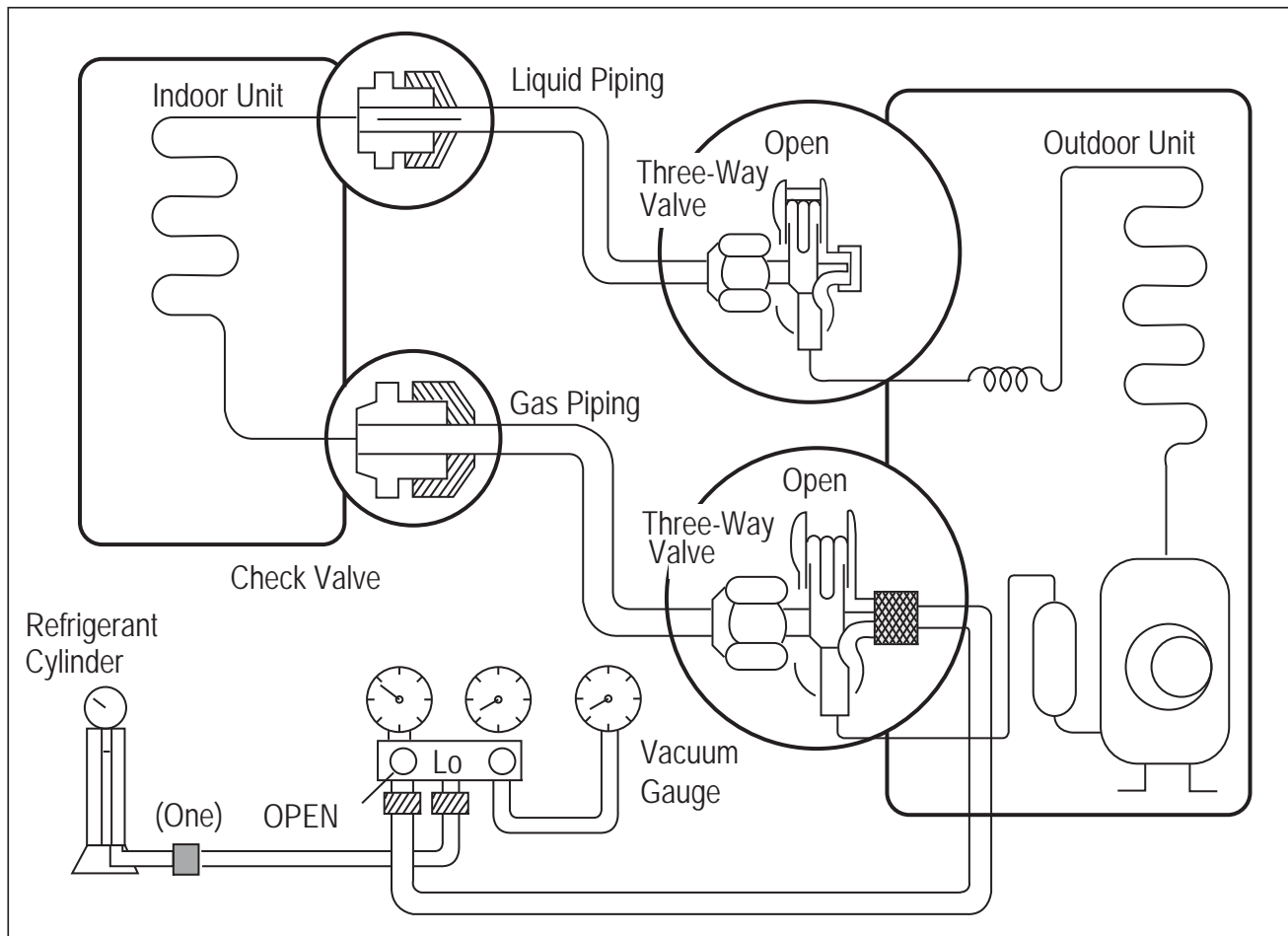

### Refrigerant Piping System Insulation

All refrigerant piping from the outdoor unit to the indoor units / BD units (Multi F MAX systems only) must be insulated correctly for safety and usage. Y-branch connections, refrigerant piping, field-provided isolation ball valves (if present), service valves, and elbows must be properly and completely insulated using closed cell pipe insulation (up to the indoor unit piping connections). To prevent heat loss / heat gain through the refrigerant piping, all refrigerant piping including liquid lines and vapor lines shall be insulated separately. Insulation shall be a minimum 1/2" thick, and thickness may need to be increased based on ambient conditions and local codes. Table below lists minimum wall thickness requirements for Ethylene Propylene Diene Methylene (EPDM) insulation.

Inside the outdoor unit, maximum pipe temperature is 248°F and minimum pipe temperature is -40°F. For field insulation of refrigerant piping between outdoor units and indoor units, consider the following pipe temperature ranges for an operating heat pump system:

- Heating mode refrigerant temperature ranges: Liquid 75-118°F; High Pressure Vapor 95-220°F
- Cooling mode refrigerant temperature ranges: Liquid 75-118°F; Low Pressure Vapor 40-90°F

Figure 60: Typical Pipe Insulation, Power Wire and Communications Cable Arrangement

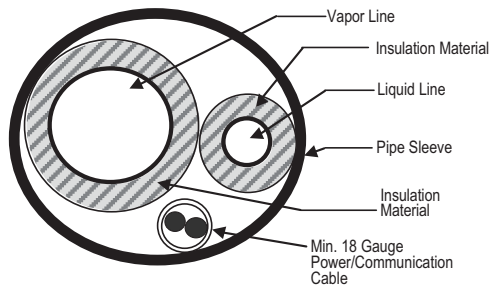

Figure 61: Typical Insulation Butt-Joint at Indoor Unit Casing

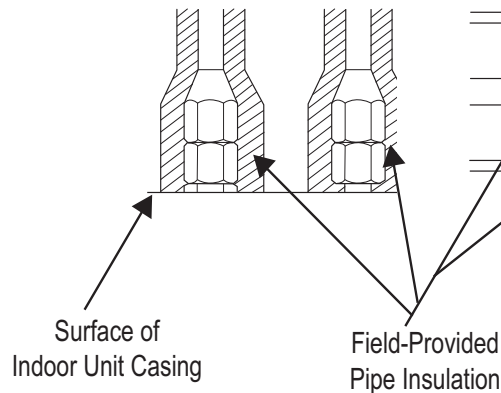
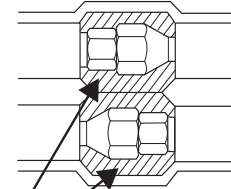

Figure 62: Typical Refrigerant Flare Fitting Insulation Detail



**Note:**

- Do not insulate gas and liquid pipes together as this can result in pipe leakage and malfunction due to extreme temperature fluctuations.
- Be sure to fully insulate the piping connections.

### Minimum Refrigerant Pipe Ethylene Propylene Diene Methylene (EPDM) Insulation Wall Thickness Requirements

**Note:**

Follow local codes when selecting EPDM insulation wall thickness.

Table 37: Insulation Guidelines for Typical and Special Circumstances

Classification		Air-conditioned location		Non-air conditioned location	
		1. Typical location	2. Special location	3. Typical location	4. Special location
Liquid pipe	ø1/4 inch	1/2 inch	1/2 inch	1/2 inch	1/2 inch
	ø3/8 inch				
	≥ø1/2 inch				
Vapor pipe	ø3/8 inch	1/2 inch	3/4 inch	3/4 inch	1 inch
	ø1/2 inch				
	ø5/8 inch				
	ø3/4 inch				
	ø7/8 inch				
	ø1 inch	3/4 inch	1 inch	1 inch	
	ø1-1/8 inches				
	ø1-1/4 inches				
	ø1-3/8 inches				
	ø1-1/2 inches				
	ø1-3/4 inches				

1. **Typical location (Air-conditioned location):** When the piping passes through an indoor area where the indoor unit operates.  
 • Apartment, classroom, office, mall, hospital, etc.

2. **Special location (Air-conditioned location):**

1. When the location is air conditioned, but there is severe temperature/humidity difference due to high ceilings  
 • Church, auditorium, theater, lobby, etc.
2. When the location is air conditioned, but internal temperature/humidity are high  
 • Bathroom, swimming pool, locker room, etc.

3. **Typical location (Non-Air conditioned location):** When the piping passes through an indoor area where the indoor unit does not operate.

- Hallway or a dormitory or school, etc.

4. **Special location (Non-Air conditioned location):** If conditions 1 and 2 below are present.

1. When the piping passes through an indoor area where the indoor unit does not operate.
2. When the humidity is high and there is no air flow in the location where the piping is installed.  
 • The thickness of the above insulation material is based on heat conductivity of 0.61 Btu/in/h/ft<sup>2</sup>/°F.

### Pipe Sleeves at Penetrations

LG requires that all pipe penetrations through walls, floors, and pipes buried underground be routed through a properly insulated sleeve that is sufficiently sized to provide free movement of the pipe and does not compress the insulation. Underground refrigerant pipe shall be routed inside a protective sleeve to prevent insulation deterioration. Also follow federal, state, and local regulations and codes when choosing a sleeve type.

### Note:

*Diameter of penetrations shall be determined by pipe diameter plus the thickness of the insulation.*

### For example:

Diameter of Gas Piping:	1/2"
Diameter of Liquid Piping:	1/4"
Thickness of Gas Piping Insulation:	0.4" x 2
Thickness of Liquid Piping Insulation:	0.4" x 2
Surplus:	0.8"
Sleeve diameter (total):	3.1" minimum

Figure 63: Pipe Sleeve Options.

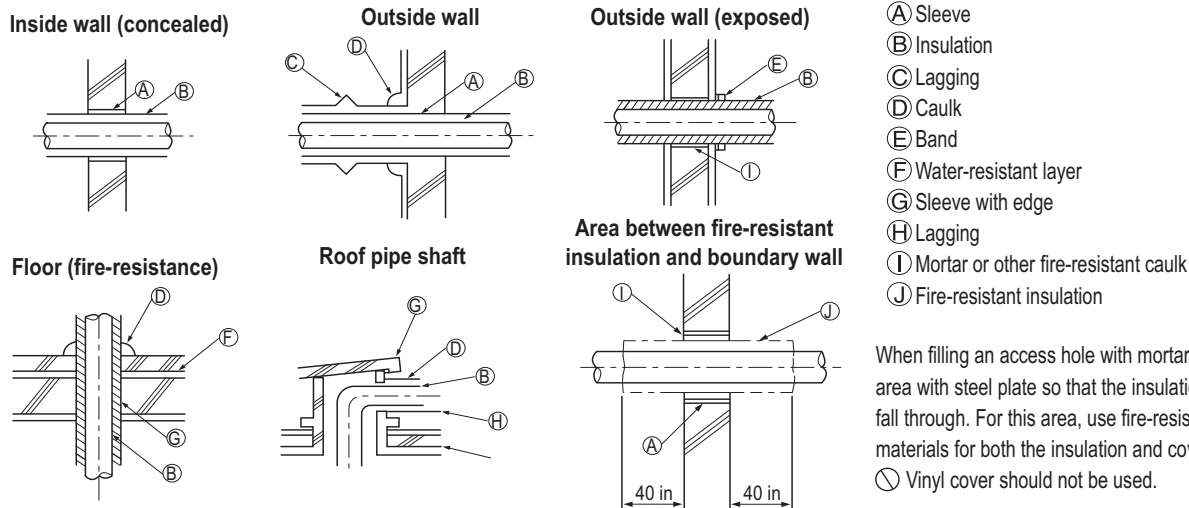

# REFRIGERANT PIPING PREPARATION

MULTI F  
MULTI F MAX

## Refrigerant Piping Insulation

### Underground Refrigerant Piping

Refrigerant pipe installed underground should be routed inside a vapor tight protective sleeve to prevent insulation deterioration and water infiltration. Refrigerant pipe installed inside underground casing must be continuous without any joints. Underground refrigerant pipe must be located at a level below the frost line.

Table 38: Utility Conduit Sizes.

Liquid Pipe <sup>1</sup>	Vapor Pipe <sup>1</sup>		
	1/2 (2.0 <sup>2,5</sup> )	5/8 (2-1/8 <sup>2,5</sup> )	3/4 (2-1/4 <sup>2,5</sup> )
1/4 (1.0) <sup>3</sup>	4	4	4
3/8 (1-1/8) <sup>3</sup>	4	4	5
1/2 (1-1/2) <sup>4</sup>	5	5	5
5/8 (1-5/8) <sup>4</sup>	5	5	5
3/4 (1-3/4) <sup>4</sup>	5	5	5

<sup>1</sup>OD pipe diameter in inches; Values in parenthesis () indicate OD of pipe with insulation jacket.

<sup>2</sup>Diameter of pipe with insulation. Thickness of pipe insulation is typical. Actual required thickness may vary based on surrounding ambient conditions and should be calculated and specified by the design engineer.

<sup>3</sup>Insulation thickness (value in parenthesis) = 3/8 inch.

<sup>4</sup>Insulation thickness (value in parenthesis) = 1 inch.

<sup>5</sup>Insulation thickness (value in parenthesis) = 3/4 inch.

Figure 64: Typical Arrangement of Refrigerant Pipe and Cable(s) in a Utility Conduit.

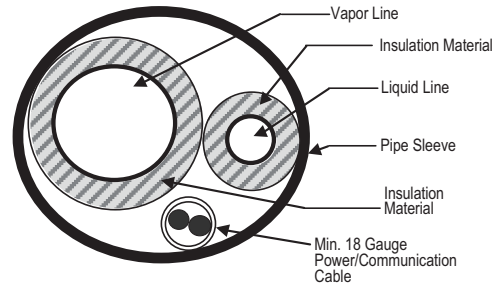

Figure 65: Underground Refrigerant Piping.



### Installing the Insulation

1. Insulation material should be longer than the refrigerant piping. Each vapor and liquid piping must be insulated separately.
2. Place the closed-cell ethylene propylene diene methylene (EPDM) insulation material carefully around each refrigerant pipe so as not to damage it. Be sure the insulation material cutting line is place upward.
3. Apply adhesive to both cut surfaces of the insulation and press together. Allow adhesive to dry so that the bond is secure and does not come apart.

### Insulating Piping Joints

1. Push the EPDM insulation from the straight piping surrounding the joint (elbow, outdoor unit to indoor unit piping connection point, etc.) as close together as possible.
2. Cut a piece of insulation to fit the joint, overlapping the insulation on the surrounding piping by at least one (1) inch.
3. Apply adhesive to bond all the ends.
4. Secure by completely wrapping narrow vinyl tape around the insulation / joint so that there are no gaps.
5. Tape should be sufficient to cover the piping so it can fit into the rear piping housing area at the back of the indoor unit or BD unit (Multi F MAX systems only).

Figure 66: Correct Cutting Line Placement.

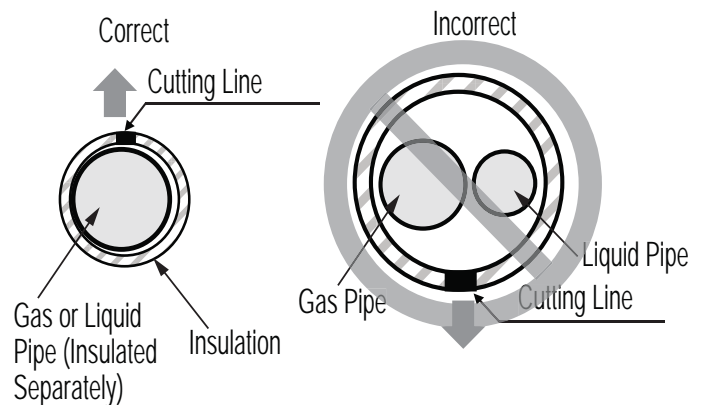
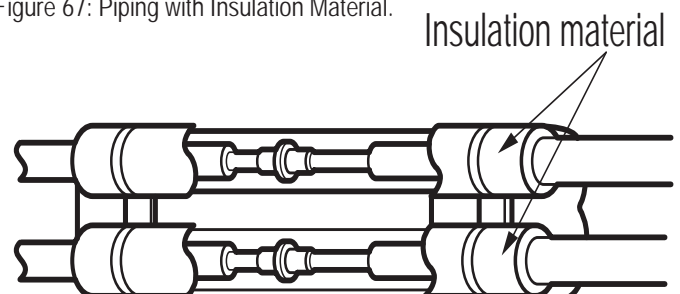

Figure 67: Piping with Insulation Material.



### Bundling

If a conduit is not used on the connection from the outdoor unit to the interior, bundle both insulated refrigerant pipes, the drain hose, and outdoor unit to indoor unit / BD unit communication cable / power wiring together with wide vinyl tape.

Figure 68: Bundling the Connection Components (From Outdoor Unit to Indoor Unit / BD Unit [Multi F MAX systems]).

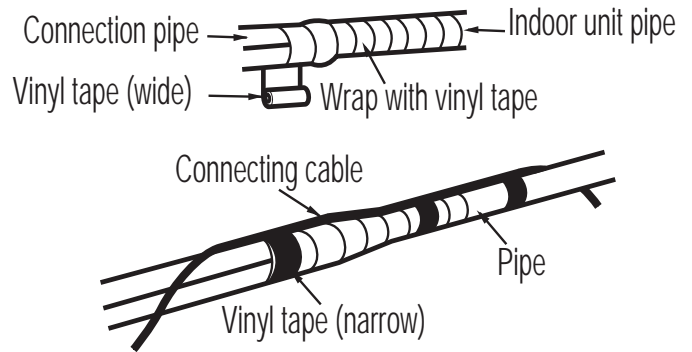

### Special Applications

If an additional drain hose is necessary, the end of drain outlet should be routed above the ground. Secure and the drain hose appropriately.

#### When the Outdoor Unit is Installed Below the Indoor Unit:

1. Wrap the vinyl tape around the separately insulated refrigerant piping, the drain hose, and the communications cable / power wiring together from the bottom to top.
2. Secure the bundle along the outside wall using saddles or a similar type of piping support.
3. Seal any openings in the wall.

#### When the Outdoor Unit is Installed Above the Indoor Unit:

1. Wrap the vinyl tape around the separately insulated refrigerant piping, the drain hose, and the communications cable / power wiring together from the bottom to top.
2. Secure a portion of the bundle along the outside wall using saddles or a similar type of piping support.
3. At the appropriate location, form a trap with the bundle to prevent water from entering interior spaces or the electrical control box of the outdoor unit.
4. Secure the rest of the bundle along the outside wall using saddles or a similar type of piping support.
5. Seal any openings in the wall.

Figure 69: Special Applications.

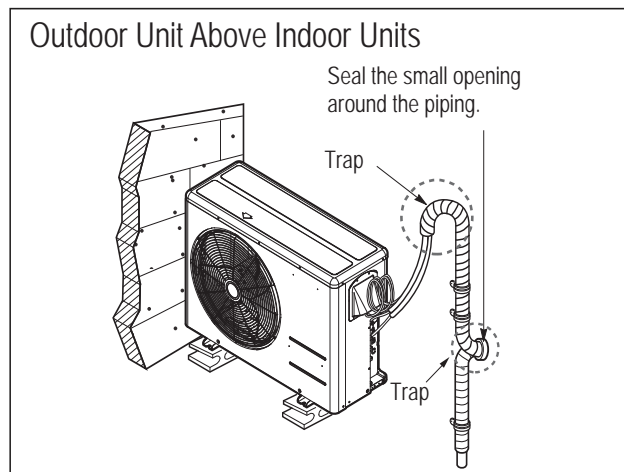
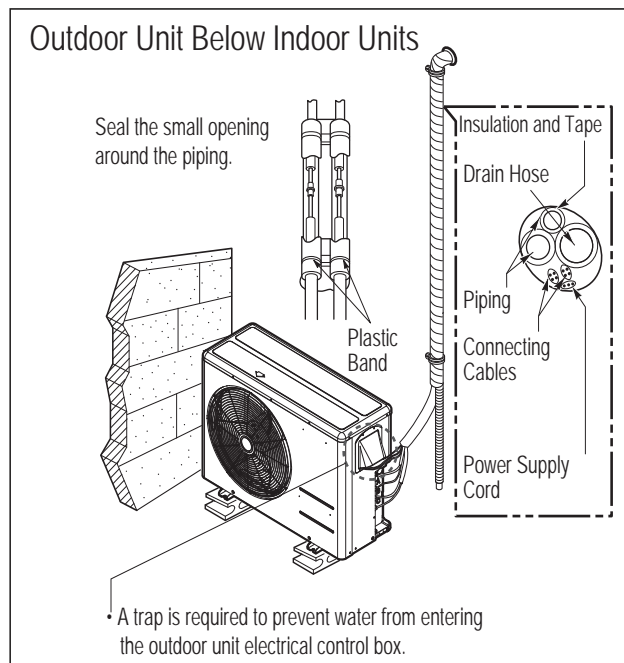

### Y-Branch Kit Insulation

Each Y-branch kit comes with clam-shell type peel-and-stick insulation jackets molded to fit the Y-branch fittings—one for the liquid line, one for the vapor line.

- Check the fit of the Y-branch clam-shell insulation jacket after the Y-branch is installed.
- Mark the pipe where the insulation jacket ends.
- Remove the jacket.
- Install field-provided insulation on the pipes first.
- Peel the adhesive glue protector slip and install the clam-shell jacket over the fitting

Figure 70: Y-branch Insulation Detail.

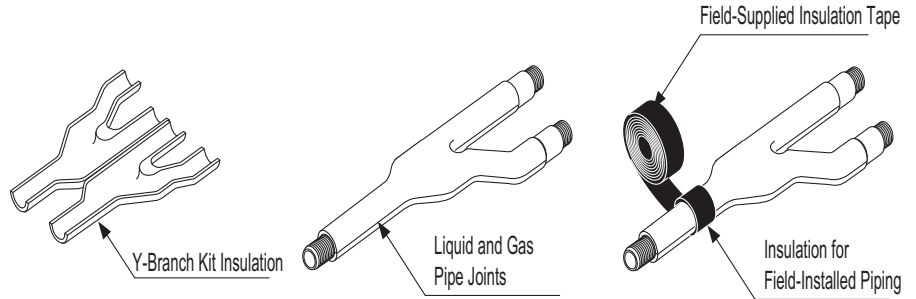

#### Note:

#### Additional Insulation for Y-Branched May be Required in Humid Environments.

If the system has been operating for a long time in a high humidity environment (dew point temperature: more than 73°F), condensate is likely to form. If this happens, install 3/8 inch thick ethylene propylene diene methylene (EPDM) insulation that is plenum-rated with a heat-resistance factor that follows applicable local, state, and federal codes.

**⚠ WARNING**

- All power wiring and communication cable installation must be performed by authorized service providers working in accordance with local, state, and National Electrical Code regulations related to electrical equipment and wiring, and following the instructions in this manual.
- Be sure that main power to the unit is completely off before proceeding. Follow all safety and warning information outlined at the beginning of this manual. Failure to do so may cause electric shock and bodily injury.
- Familiarize yourself with the location of the circuit breaker. Be sure that a circuit breaker or some other emergency power cutoff device is in place before any power wiring is done to the system. Failure to do so may cause bodily injury or death.
- ⚡ Never touch any power lines or live cables before all power is cutoff to the system. To do so, may cause bodily injury or death.
- Undersized wiring may lead to unacceptable voltage at the unit and may become a fire hazard, causing bodily injury or death
- Properly ground the outdoor units. Ground wiring is required to prevent accidental electrical shock during current leakage.
- Install appropriately sized breakers / fuses / overcurrent protection switches and wiring in accordance with local, state, and National Electrical Code regulations related to electrical equipment and wiring, and following the instructions in this manual. Using an oversized breaker or fuse may result in electric shock, physical injury or death.
- ⚡ Do not connect ground wire to refrigerant, gas, or water piping; to lightning rods; to telephone ground wiring; or to the building plumbing system. Failure to properly provide a National Electrical Code-approved earth ground can result in electric shock, physical injury or death.

**Note:**

- Consider ambient conditions (temperature, direct sunlight, inclement weather, etc.) when selecting, installing, and connecting the power wiring.
- Properly ground the outdoor units. Improperly ground wire can cause communication problems from electrical noise and motor current leakage. Ground wiring must always be installed by a qualified technician.
- If the system operates in reversed phase, it may damage the compressors and other components.
- If there is a possibility of reversed phase, phase loss, momentary blackout, or the power goes on and off while the system is operating, install a field-supplied phase loss protection circuit.
- Undersized wiring may lead to unacceptable voltage at the unit and may cause unit malfunction.
- Install appropriately sized breakers / fuses / overcurrent protection switches and wiring in accordance with local, state, and National Electrical Code regulations related to electrical equipment and wiring, and following the instructions in this manual. Using an oversized breaker or fuse may result in equipment malfunction and property damage.
- ⚡ Do not connect ground wire to refrigerant, gas, or water piping; to lightning rods; to telephone ground wiring; or to the building plumbing system. Failure to properly provide a National Electrical Code-approved earth ground can result in property damage and equipment malfunction.

**Power Supply / Power Wiring Specifications**

**Note:**

- Multi F and Multi F MAX systems operate at 1Ø, 208-230V, 60Hz.
- Power supply, wire type and size should be selected based on National Electrical Code and local codes. Maximum allowable voltage fluctuation ±10% or nameplate rated value.
- Properly ground the outdoor units per National Electrical Code and local codes.
- For power to the outdoor units, use field-supplied copper wiring that is solid or stranded, and shielded with the wires separately insulated.
- Ground wire should be longer than the common power / communication wires.
- Connect the wiring firmly so the wires cannot be easily pulled out.
- Refer to the inside of the chassis cover for circuit and terminal block diagrams for your model unit.
- Always match color codes of each wire and follow wiring diagram.
- Outdoor unit wiring can be found on the inside of the outdoor unit control cover.

**Note:**

It is highly recommended to provide a circuit breaker between the power source and the outdoor unit as shown.

Table 39: Circuit Breaker / Fuse Size.

Outdoor Unit Model	Power Source	Fuse or Breaker Capacity
LMU18CHV, LMU24CHV	1Ø, 208-230V	20A
LMU30CHV, LMU36CHV	1Ø, 208-230V	25A
LMU480HV, LMU540HV	1Ø, 208-230V	40A
LMU600HV	1Ø, 208-230V	45A

Figure 71: Circuit Breaker  
Main Power Source

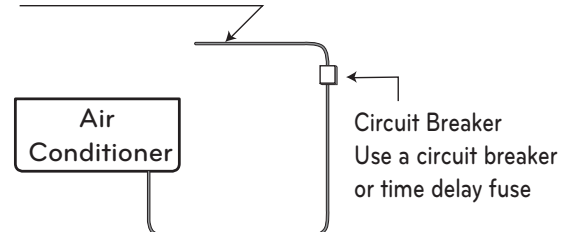

### General Communication Cable Specifications

- Multi F Systems: All power wiring / communication cable to be minimum 18 AWG from the outdoor unit to the indoor unit, stranded, shielded or unshielded (if shielded, it must be grounded to the chassis of the outdoor unit only), and must comply with applicable local and national codes.
- Multi F MAX Systems: All power wiring / communication cable to be minimum 16 AWG from the outdoor unit to the BD unit, and 18 AWG from the BD unit to the indoor unit, stranded, shielded or unshielded (if shielded, it must be grounded to the chassis of the outdoor unit only), and must comply with applicable local and national codes.
- For power / communication wires between the Multi F and Multi F MAX outdoor units and the indoor units / BD units (Multi F MAX systems only), use a four (4) conductor, stranded, shielded or unshielded wire. If shielded, the wire must be grounded to the chassis at the outdoor unit only.
- Insulation material as required by local code.
- Rated for continuous exposure of temperatures up to 140°F.
- Firmly attach the cable; provide slack but secure in a way to prevent external forces from being imparted on the terminal block.
- Wiring should be completed without splices.

#### Note:

- Always verify the communication cable is connected to a communications terminal. Never apply line voltage power to the communication cable connection. If contact is made, the PCBs may be damaged.
- The shield of the communications cable connecting the outdoor unit to the indoor units should be grounded only to the outdoor unit frame.
- Tie the shield of each cable segment together using a wire nut at the indoor unit. Maintain polarity throughout the communication network.
- Position the incoming power to the outdoor unit away from the power / communications cables from the outdoor unit to the indoor unit / branch distribution unit (Multi F MAX systems only).
- ⓧ Never use a common multiple-core communications cable. Each communications bus shall be provided a separate cable (i.e., between outdoor unit and indoor unit).

### Outdoor Unit Wiring Connection Guidelines

Best practice dictates using ring or spade terminals to terminate power wiring at the power terminal block

#### To Install a Ring Terminal:

1. Trim the strand wiring with wire cutters or pliers, then strip the insulation to expose the strand wiring to about 3/8 inch.
2. Using a ring terminal fastener or pliers, securely clamp a ring terminal to each stripped wire end.

#### To Connect the Wiring to the Terminals:

1. Remove the terminal screws from the (outdoor unit, BD unit, or indoor unit) terminal plate with a screwdriver.
2. Position the ring terminal around the terminal, place the terminal screw in the ring, and tighten to the terminal plate using a screwdriver.

Figure 72: Multi F / Multi F MAX Outdoor and Indoor / Branch Distribution Unit Wiring and Communications Cable Diagram.

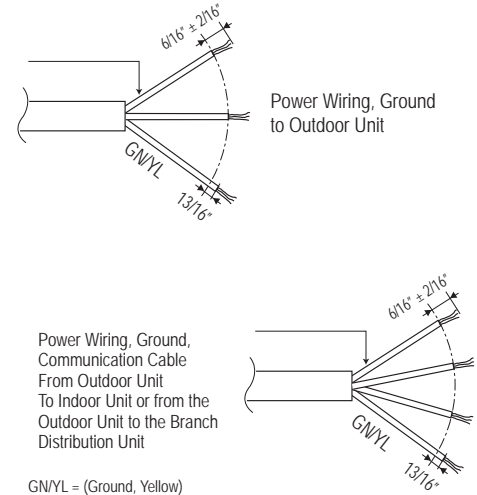

Figure 73: Close up of a Typical Ring Terminal

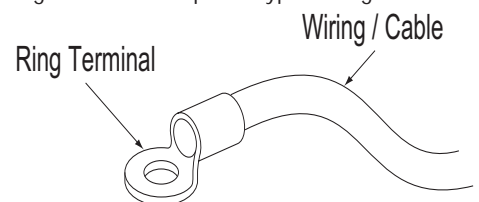
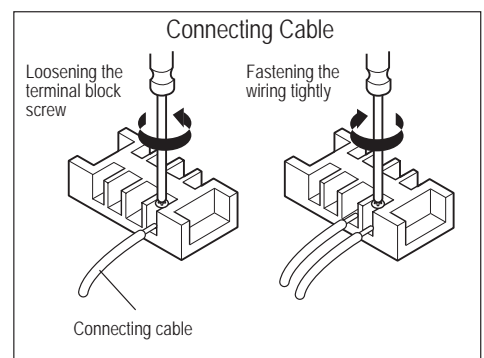

Figure 74: Tightening the Ring Terminal to the Terminal Plate.



**Outdoor Unit Wiring Connection Guidelines, continued.**

If ring terminals or spade clips are not available, then:

**Note:**





-  Do not terminate different gauge wires to the power terminal block. Slack in the wiring may generate heat and fire.
-  Do not over tighten the connections; overtightening may damage the terminals.
- When terminating wires of the same thickness, follow the instructions demonstrated in the illustrations below.
- Firmly attach the wire; secure in a way to prevent external forces from being imparted on the terminal block.
- Use an appropriately sized screwdriver for tightening the terminals.

Figure 75: Proper and Improper Power Wiring Connections

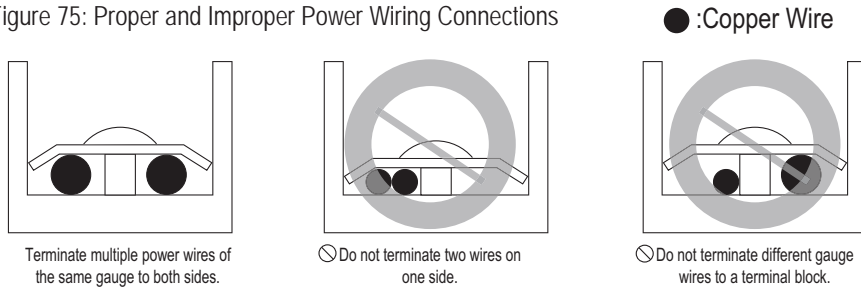

**Note:**

-  Never apply line voltage power to the communications cable terminal block. If contact is made, the PCBs may be damaged.
- Always include some allowance in the wiring length when terminating. Provide some slack to facilitate removing the electrical panels while servicing.



**⚠ WARNING**

- If power wires are not properly terminated and firmly attached, there is risk of fire, electric shock, and physical injury or death.
-  Never ground the shield of the communications cable to the indoor unit frame or other grounded entities of the building. Failure to properly provide a National Electrical Code-approved earth ground can result in electric shock, physical injury or death.

**Connecting the Power Wiring / Communications Cable to the Outdoor Unit**

1. Remove the side panel and the conduit panel knockouts.
2. Detach the control cover by loosening and removing the screws.
3. Draw the power wiring to the outdoor unit, and the power wiring / communications cable (connecting cable) to the indoor units or BD unit (Multi F MAX systems only), through field-supplied conduits. Ensure there is enough length to connect the wiring / cables to the terminals on the outdoor unit. Secure the conduit to the outdoor unit using a field-supplied lock nut on the interior of the outdoor unit frame.
4. Properly connect the power wiring, and the power wiring / communications cable (connecting cable) to the correct terminals. Refer to the outdoor unit wiring diagram.
5. To provide strain relief, (separately) secure the power wiring and the power wiring / communications cable (connecting cable) to the outdoor unit with the factory-supplied clamps (up to 35 lbs.). Zip ties can also be used to hold all wiring / cables in place.
6. Re-attach the outdoor unit cover control and side panel to the original position with the screws.

**⚠ DANGER**

-  Do not use damaged or loose power wiring.  Do not modify or extend the outdoor unit's power wiring randomly. Ensure that the power wiring will not be pulled nor weight be placed on the power wiring during operation. There is risk of fire, electric shock, and physical injury or death.

### Connecting the Power Wiring / Communications Cable to the Outdoor Unit, continued.

Figure 76: Connecting the Power Wiring / Communications Cables to the Outdoor Unit (LMU18-36CHV; LMU480, 540HV).

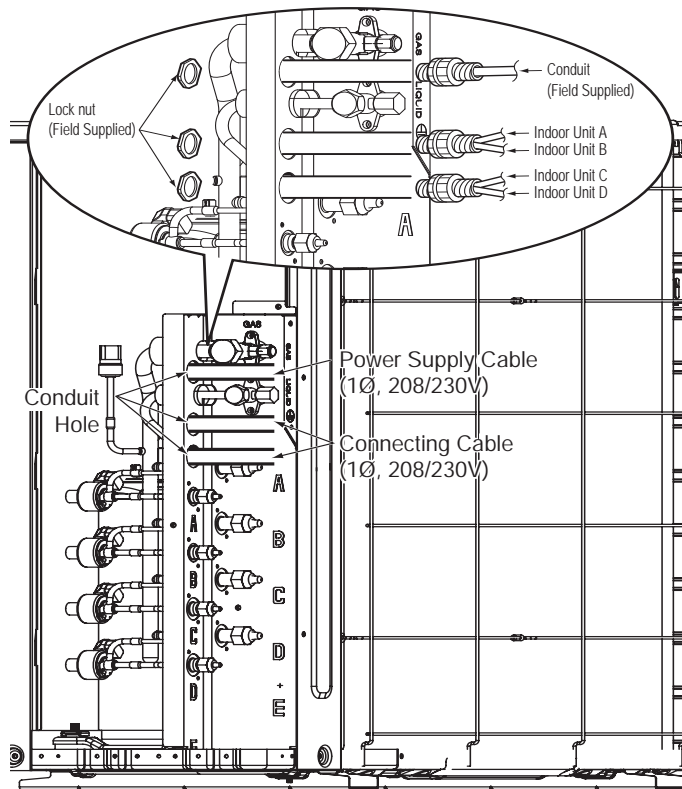
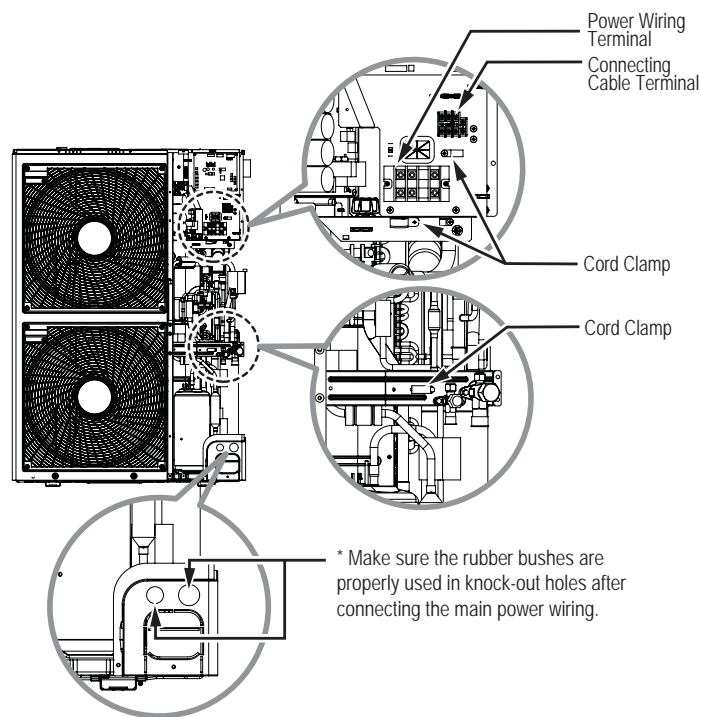

Figure 77: Connecting the Power Wiring / Communications Cables to the Outdoor Unit (LMU600HV).



### ⚠ WARNING

- Secure all field wiring connections with appropriate wire strain relief. Improperly securing wires will create undue stress on equipment power lugs. Inadequate connections may generate heat, cause a fire and physical injury or death.
- Properly tighten all power lugs. Loose wiring may overheat at connection points, causing a fire, physical injury or death.
- Replace all control box and panel covers. If cover panels are not installed securely, dust, water and animals may enter the outdoor unit, causing fire, electric shock, and physical injury or death.

### Note:

- The communications cable (connecting cable) from the outdoor unit to the indoor unit should be isolated from the electrical wiring of external devices such as computers, elevators, radio and television broadcasting facilities, and medical imaging offices. Communication problems can arise from electrical noise.
- ⓧ Do not install the power wiring to the outdoor unit and the power wiring / communications cable (connecting cable) to the indoor units in the same conduit. These wiring / cables should have separate conduits that are placed a reasonable distance apart. Communication problems can arise from electrical noise.

Connecting the Power Wiring / Communications Cable to the Outdoor Unit, continued.

Figure 78: Detailed View of Outdoor Unit Terminal Blocks / Connections.

Multi F LMU18CHV

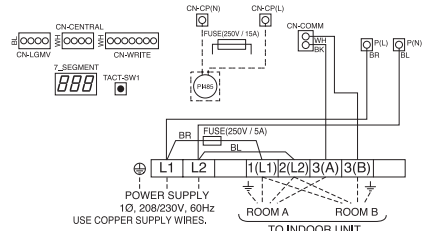

Multi F LMU24CHV

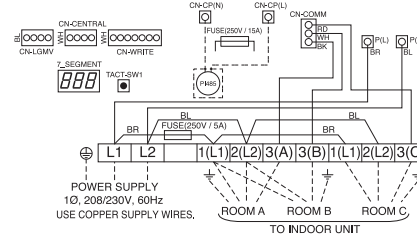

Multi F LMU30CHV and LMU36CHV

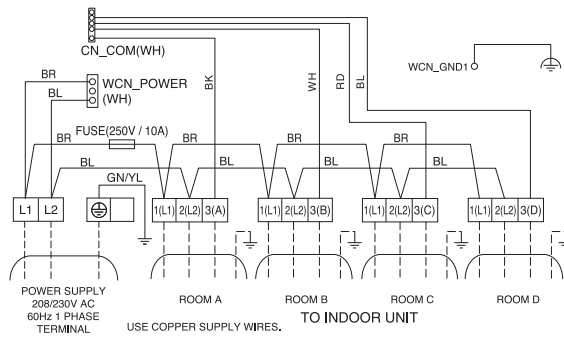

Multi F MAX LMU480HV and LMU540HV

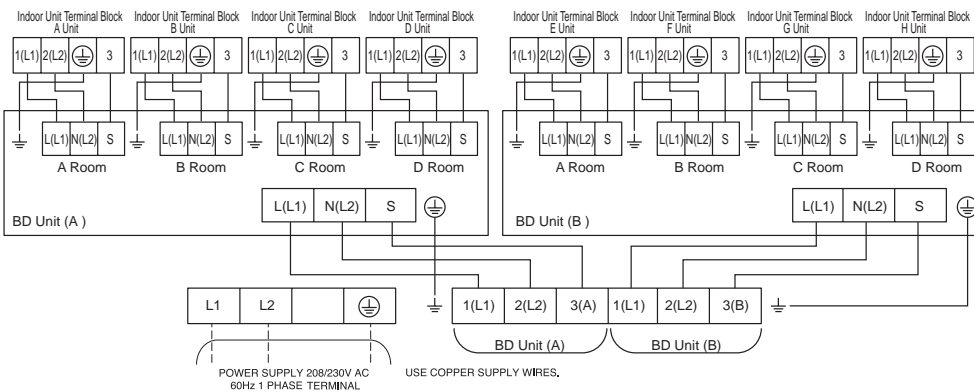

Multi F MAX LMU600HV

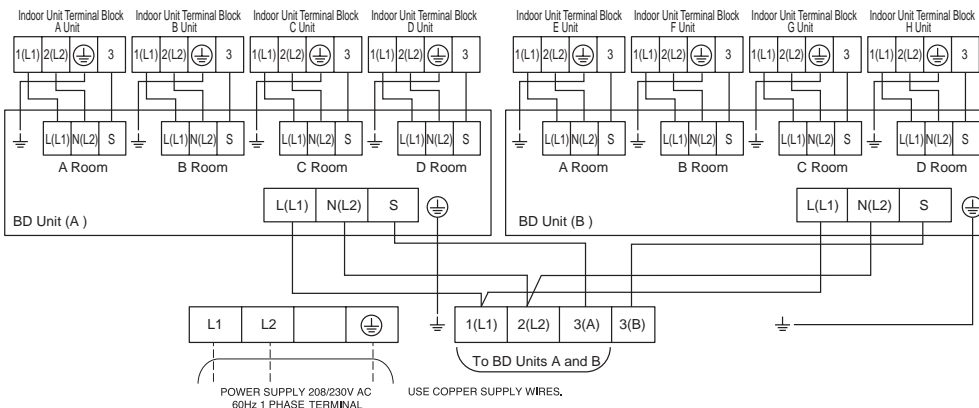

### Connecting the Power Wiring / Communications Cable to Indoor Units

1. Connect power wiring / communications cable (connecting cable) from the outdoor unit to the individual indoor unit terminals following the wiring diagrams on the outdoor unit and indoor unit control covers.
2. Ensure that the terminal board numbers (A, B, C; 1, 2, 3) and wiring color on the outdoor unit matches the terminal number and wiring color on the indoor unit. (Terminal board numbers are arranged from top to bottom in order from 1 to 3.)
3. Provide strain relief by securing the wiring / cable to the indoor unit with the factory-supplied clamps.
4. For more installation information for specific indoor units, refer to the separate indoor unit installation manuals on [www.lg-dfs.com](http://www.lg-dfs.com).

### Connecting the Power Wiring / Communications Cable to the Branch Distributor (BD) Unit (Multi F MAX Systems Only)

#### General Instructions

- Always connect power wiring / communications cable matching the BD unit terminals to their respective indoor units (Example for three-port BD Unit PMBD3630: A, B, and C).
- Follow the instructions on the nameplates and connect wiring / cables of the outdoor unit and indoor units to the correct terminals (1, 2, 3). Always attach each ground wire separately to a grounding screw.
- After completion, secure wiring with wire clamps. Secure wiring firmly to the indoor unit.

Figure 79: Interior View of a BD Unit (Three-Port PMBD3630 Example Shown).

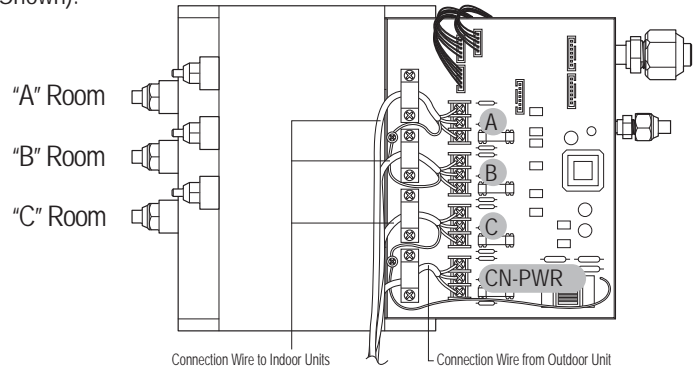

#### BD Unit Wiring Connection Procedure

1. Remove the BD unit control cover. Unscrew the two (2) screws, and slide the cover off the BD frame following the arrows in the diagram (Step 1).
2. Draw the power wiring / communications cable through the field-supplied conduit so there is enough length to connect wiring / cable to the terminals on the BD unit. Secure conduit to the BD unit using a field-supplied lock nut on the interior of the BD unit frame (Step 2).
3. Connect wiring / cable from the outdoor unit to the BD unit terminals, and from the BD unit terminals to the indoor unit terminals following the wiring diagram on the outdoor unit control cover (Step 3). Allow 11-13/16 inches of slack in the wire harness. Attach wiring / cable to the BD unit with clamps at four (4) locations.
4. Replace the BD unit control cover following the arrows in the diagram. Tighten the two (2) screws to finish (Step 4).

Figure 80: BD Unit Wiring Steps.

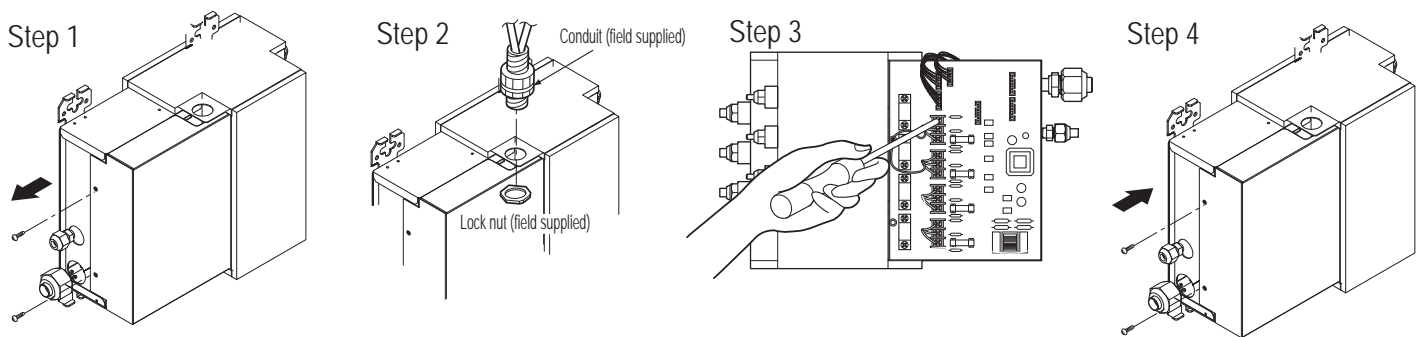

#### ⚠ WARNING

⊘ Do not use tapped wires, extension cords, or starburst-type connections as they may cause overheating, fire, electric shock, physical injury or death.

#### Note:

Always refer to the circuit diagram on the inside of the outdoor unit control cover.

**PI485**

PI485 V-net Control Integration Board for Outdoor Units adapt Multi F, Multi F MAX systems to a LG VRF system central protocol for integration with LG central controllers. The PI485 is installed in the Multi F / Multi F MAX outdoor unit. For more information on PI485 installation, see the PI485 installation manual.

Figure 81: PI485 Board (Appearance may differ depending on model).



Multi F LMU18CHV, LMU24CHV

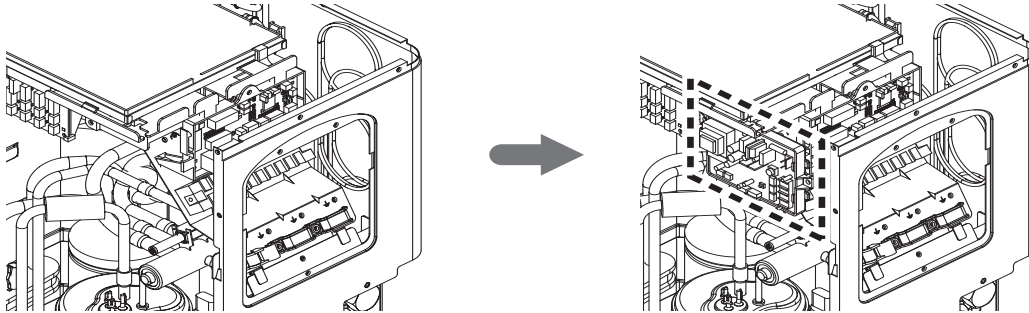

Multi F LMU30CHV, LMU36CHV

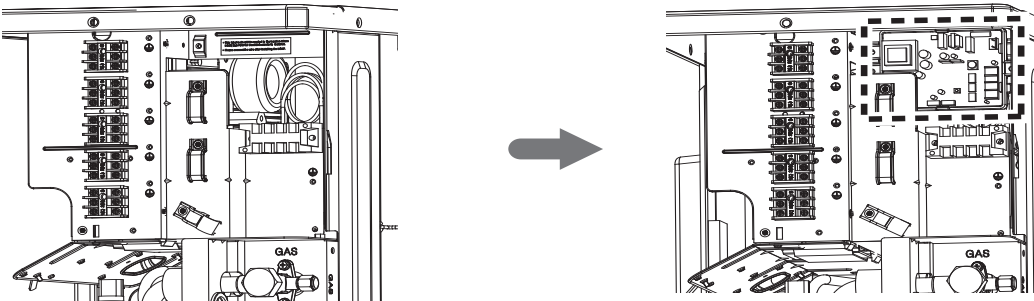

Multi F MAX LMU480HV, LMU540HV

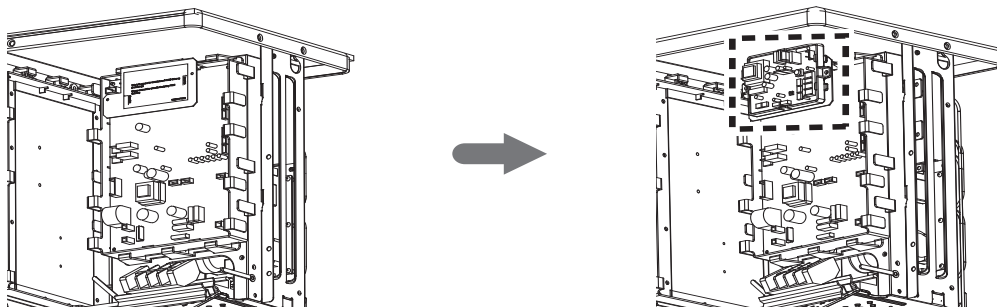

Multi F MAX LMU600HV



## Test Run

After checking the system for leaks and performing the evacuation procedure, perform a test run. Follow the guidelines below for proper procedure.

### Before the Test Run

1. Check that all condensate tubing, refrigerant piping and power wiring / communications cables are properly connected.
2. Make sure that the gas and liquid service valves are fully open.

### Installing the Remote Controller Batteries

As part of the test run, the batteries need to be inserted into the remote controller, and the remote controller needs to be powered on to operate the indoor units. To insert the batteries follow the steps below. For information on using the remote controller, refer to its owner's manual.

1. The remote controller needs two AAA (1.5V) batteries for operation. Remove the battery cover from the back of the remote controller by pushing downward on the tab at the top of the battery cover and then lift up to remove.
2. Insert the two new batteries. Align batteries by the (+) and (-) sides (the interior battery compartment of the remote controller will have clear markings for the (+) and (-) placement).
3. Verify that the batteries have "clicked" into the compartment and are firmly engaged with the contacts on either side of them.
4. Reattach the back cover of the remote controller.
5. Proceed with powering on the remote controller and usage as needed.

### Test Run Procedure

1. Start up the system and perform a test run. Operate the system in cooling mode for 15 to 20 minutes.
2. Evaluate performance as the system runs, verifying the outdoor unit and all indoor units and BD units (Multi F MAX systems only) are working properly. Make notes as needed to address any issues that might be found.
  - Check the system refrigerant charge:
    - Measure the pressure from the gas side service valve.
    - Measure the indoor unit inlet and outlet air temperatures. See table below for the optimum condition of the gas side pressure (system is in cooling mode).

Table 40: Optimum Conditions of the Gas Side Pressure.

Refrigerant Type	Outside Ambient Temperature	Gas Side Service Valve Pressure
R410A	95°F	113-142 psig

Figure 85: Inlet and Outlet Temperature Locations on Various Indoor Units.

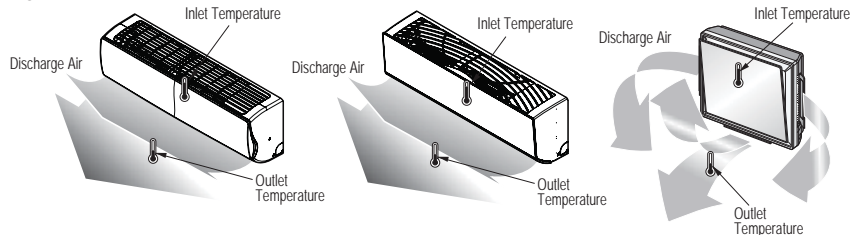

### Note:

If the pressure is >142psig, the system is most likely overcharged, and refrigerant should be removed. If the pressure is <113 psig, the system is most likely undercharged and refrigerant should be added.

Figure 83: Piping Connection on the Outdoor Unit (May Differ Depending on Outdoor Unit Model).

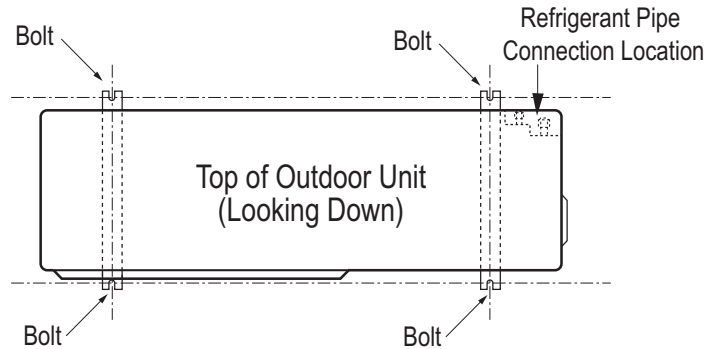
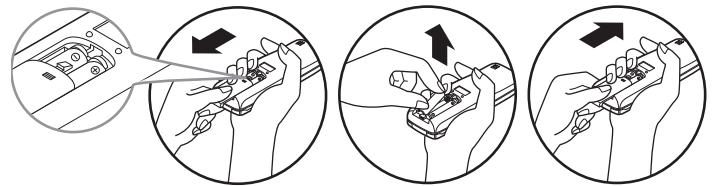

Figure 84: Installing the Remote Controller Batteries.



## Outdoor Unit DIP Switch Settings

System must be powered off, and then turned back on to apply DIP switch settings.

### ⚠ WARNING

Turn off the circuit breaker or shut the power source of the product down before setting the DIP switch. There is risk of physical injury or death due to electric shock.

### Note:

- Unless the applicable DIP switch is set properly, the system may not work.
- If a specific function is desired, request that the installer set the appropriate DIP switch during installation.
- Only the first four DIP switches are functional on the LMU480, 540, 600HV.

Table 41: DIP Switch Settings and Functionalities.

DIP Switch Setting	Function
	Normal Operation (No Function)
	Forced Cooling Operation
	Wiring Error Check
	Reducing Power Consumption (Step 1)
	Reducing Power Consumption (Step 2)
	Mode Lock (Cooling)
	Mode Lock (Heating)
	Night Quiet Mode (Step 1)
	Night Quiet Mode (Step 2)
	Mode Lock (Cooling) + Night Quiet Mode (Step 1)
	Mode Lock (Cooling) + Night Quiet Mode (Step 2)
	Reducing Power Consumption (Step 1) with Mode Lock (Cooling)
	Reducing Power Consumption (Step 2) with Mode Lock (Cooling)
	Reducing Power Consumption (Step 1) with Mode Lock (Heating)
	Reducing Power Consumption (Step 2) with Mode Lock (Heating)

Figure 86: LMU18~36CHV Outdoor Unit DIP Switches (in Normal Operation Setting).

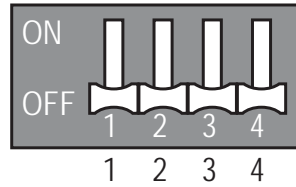

Figure 87: LMU480-540HV Outdoor Unit DIP Switches (in Normal Operation Setting).

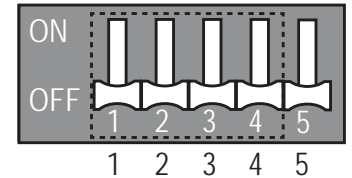
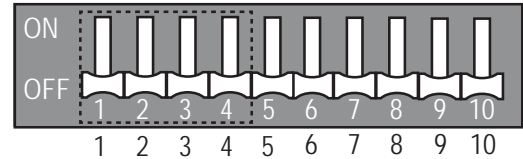

Figure 88: LMU600HV Outdoor Unit DIP Switches (in Normal Operation Setting).



## Location of DIP Switches on Multi F and Multi F MAX Outdoor Units

Figure 89: Multi F / Multi F MAX Outdoor Unit DIP Switch Locations.

Multi F LMU18CHV and LMU24CHV

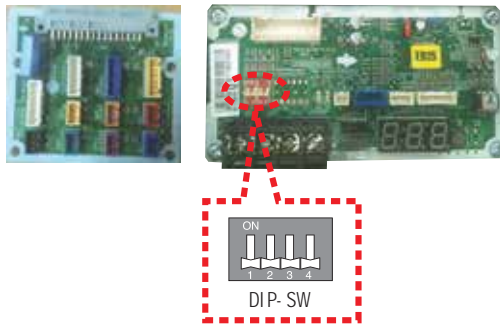

Multi F LMU30CHV and LMU36CHV

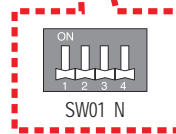

Multi F MAX LMU480HV and LMU540HV

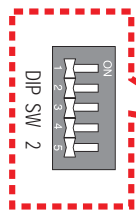
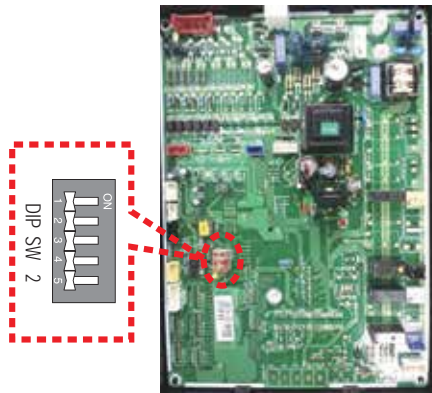

Multi F MAX LMU600HV

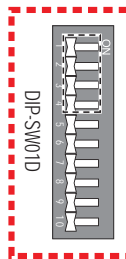
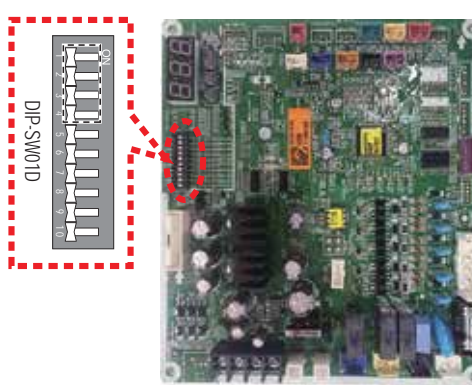

### Forced Cooling Operation Function

Use to add refrigerant to the system when outside ambient temperatures are cool (ex.: winter).

1. Shut power down to the system.
2. Set DIP Switch 1 to ON.
3. Turn power on to the system.
4. Verify that the Red LED on the outdoor unit PCB is ON (indicates indoor units are in forced cooling operation).
5. Add refrigerant.

#### Note:

- If the green LED light on the outdoor unit PCB is ON, it indicates the compressor is OFF due to low pressure in the system.
- Turn DIP Switch 1 to OFF after finishing (Normal Operation setting).
- Only the first four DIP switches are functional on the LMU480, 540, 600HV.

Figure 90: Forced Cooling DIP Switch Setting.

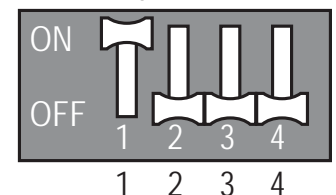

**Wiring Error Check**

Use to verify if wiring is properly installed.

1. Shut power down to the system.
2. Set DIP Switch 2 to ON.
3. Turn power on to the system.
4. Check if the Red and Green LEDs on the outdoor unit PCB are ON (indicate indoor units are in forced operation mode).
5. If the wiring is correctly installed, the Green LED will light up. If the wiring is incorrectly installed, the Red and Green LEDs will blink, indicating which part of the system is in error.
  - Red LED = Piping Number
  - Green LED = Wiring Number (Room)

Example: If the Red LED blinks twice and the Green LED blinks three times, the second piping to the third room is in error (see at right).

**Note:**

- If the indoor unit(s) are not communicating properly to the outdoor unit, the Wiring Error Check cannot operate correctly.
- Only the part of the system in error will be displayed. System will operate correctly after the error is fixed.
- If outdoor and indoor temperatures are too low (ex.: winter), the wiring error check function will not operate (Red LED is ON).
- Turn DIP Switch 2 to OFF after finishing (Normal Operation setting).
- Only the first four DIP switches are functional on the LMU480, 540, 600HV.

Figure 91: Wiring Error Check DIP Switch Setting.

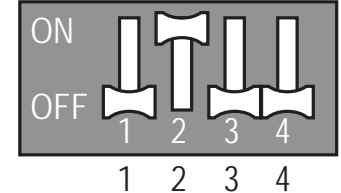
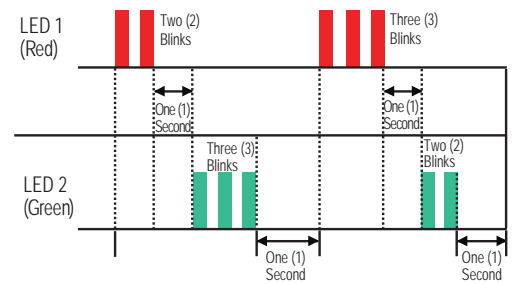

Figure 92: Wiring Error Check Example.



**Reducing Power Consumption**

Enables more efficient system operation by reducing the maximum power consumption value (reducing the MCA).

1. Shut power down to the system.
2. For Step 1, set only DIP Switch 3 to ON. For Step 2, set only DIP Switch 4 to ON.
3. Turn power on to the system.

Figure 93: Reducing Power Consumption Chart.

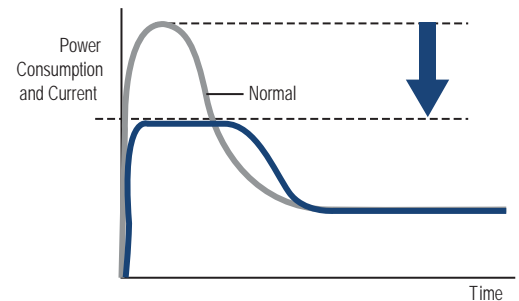
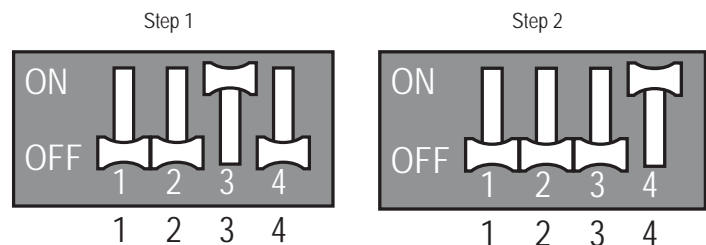

Table 42: Reducing Power Consumption Current Levels.

Phase	1Ø		
Model	Multi F LMU18CHV, LMU24CHV	Multi F LMU30CHV, LMU36CHV	Multi F MAX LMU480HV, LMU540HV, LMU600HV
Step 1 (A)	9	13	22
Step 2 (A)	8	11	21

Figure 94: Reducing Power Consumption DIP Switch Settings.



**Note:**

- Reduced Power Consumption reduces outdoor unit capacity.
- Only the first four DIP switches are functional on the LMU480, 540, 600HV.

## Reducing Power Consumption with Mode Lock

Enables more efficient system operation by lowering the maximum power consumption value, as well as locks the mode of operation (Example: In a cooling-only server room application where permission to adjust the system mode is highly limited). Changing modes can cause a change in compressor frequency, which would cause problems with the setting. As such, if this mode is used, it is locked in either cooling or heating. The function is rarely, if ever, used.

1. Shut power down to the system.
2. Set DIP Switches as indicated below, following the steps and chosen mode.
3. Turn power on to the system.

### Note:

Only the first four DIP switches are functional on the LMU480, 540, 600HV.

Figure 95: Saving Power Consumption with Mode Lock DIP Switch Settings.

Step 1: Reducing Saving Power Consumption + Mode Lock (Cooling)

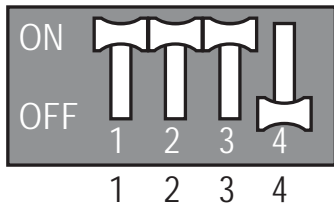

Step 2: Reducing Saving Power Consumption + Mode Lock (Cooling)

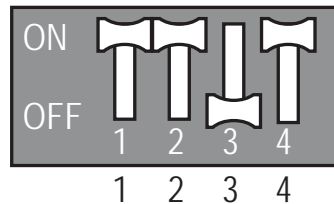

Step 1: Reducing Saving Power Consumption + Mode Lock (Heating)

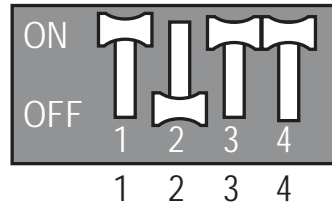

Step 2: Reducing Saving Power Consumption + Mode Lock (Heating)

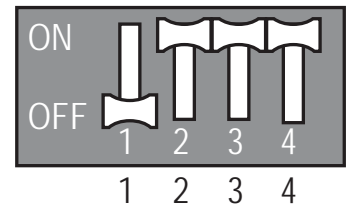

## Night Quiet Mode

Lowers the operation sound of the outdoor unit by changing the compressor frequency and fan speeds. Night quiet mode initiates eight (8) hours after the highest outdoor air temperature is measured, then is active for nine (9) hours.

1. Shut power down to the system.
2. For Step 1, set only DIP Switches 2 and 3 to ON. For Step 2, set only DIP Switches 1 and 4 to ON.
3. Turn power on to the system.

## Night Quiet Mode with Mode Lock

Lowers the operation sound of the outdoor unit by changing the compressor frequency and fan speeds, as well as locks the mode of operation. Changing modes can cause a change in compressor frequency, which would cause problems with the setting. As such, if this mode is used, it is locked in either cooling or heating. The function is rarely, if ever, used. Night quiet mode initiates eight (8) hours after the highest outdoor air temperature is measured, then is active for nine (9) hours.

1. Shut power down to the system.
2. For Step 1, set only DIP Switches 2 and 4 to ON. For Step 2, set DIP Switches 1 and 3 to ON.
3. Turn power on to the system.

### Note:

- If compressor frequency and fan speed are decreased, cooling capacity also may decrease accordingly.
- Night Quiet Mode can only be used when system is in cooling operation.
- Change the DIP switches if Night Quiet Mode is no longer desired.
- If indoor unit operation is set by the fan speed "Power", Night Quiet Mode will not function until fan speed "Power" is changed.
- Only the first four DIP switches are functional on the LMU480, 540, 600HV.

Figure 96: Night Quiet Mode DIP Switch Settings.

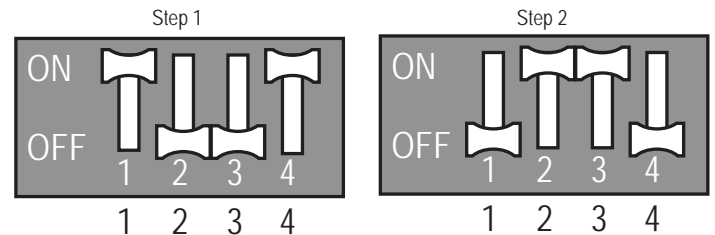
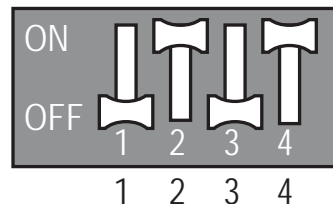
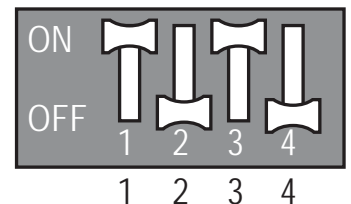

Figure 97: Night Quiet Mode with Mode Lock DIP Switch Settings.

Step 1: Night Quiet Mode + Mode Lock (Cooling)



Step 2: Reducing Saving Power Consumption + Mode Lock (Cooling)



**Mode Lock**

Prevents mixed mode operation (mode change) in applications where only one mode is necessary.

1. Shut power down to the system.
2. For Only Cooling Mode Lock, set only DIP Switches 1 and 2 to ON. For Only Heating Mode Lock, set only DIP Switches 3 and 4 to ON.
3. Turn power on to the system.

**Note:**

Only the first four DIP switches are functional on the LMU480, 540, 600HV.

Figure 98: Mode Lock DIP Switch Settings.

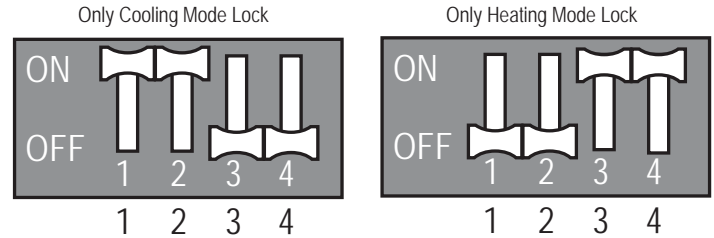

**PCB Display (Multi F LMU18-24CHV and LMU600HV Models Only)**

For Multi F LMU18CHV, LMU24CHV, and LMU600HV outdoor units, the cycle data can be checked without using LG Monitoring View (LGMV) Diagnostic Software by pushing TACT-SW1. See below for the types of cycle information that will be displayed in LGMV. After first page is displayed, the second page will be subsequently displayed.

Figure 99: Location of TACT-SW1 (LMU18-24CHV).



Figure 100: Location of TACT-SW1 (LMU600HV).

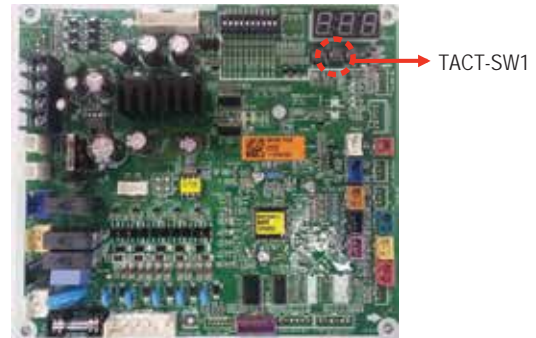

**⚠ WARNING**

Protect fingers / hands with a non-conducting material before pushing TACT-SW1. There is risk of physical injury or death due to electric shock.

Table 43: PCB Display Information.

TACT-SW1 No. of Pushes	Description	Display		
		Example	First Page	Second Page
One (1) Time	Low Pressure	890kpa	"LP"	"89"
Two (2) Times	High Pressure	2,900kpa	"HP"	"290"
Three (3) Times	Discharge Temperature	85°C	"DS"	"85"
Four (4) Times	Condenser Outlet Temperature	-10°C	"CS"	"-10"
Five (5) Times	Suction Temperature	-10°C	"SS"	"-10"
Six (6) Times	Outdoor Unit Air Temperature	-10°C	"AS"	"-10"
Seven (7) Times	Current	15A	"A"	"15"
Eight (8) Times	Voltage	230V	"V"	"230"
Nine (9) Times	Compressor Hz	100Hz	"F"	"100"
Ten (10) Times	DC Link Voltage	230V	"dc"	"230"

### LG Monitoring View (LGMV) Diagnostic Software

LGMV software (PRCTSL1 and PRCTFE1) allows the service technician or commissioning agent to connect a computer USB port to the Multi F / Multi F MAX system's main printed circuit board (PCB) using an accessory cable without the need for a separate interface device. The monitoring screen for LGMV allows the user to view the following real time data on one screen:

- Actual inverter compressor speed
- Target inverter compressor speed
- Actual outdoor fan speed
- Target outdoor unit fan speed
- Actual superheat
- Target superheat
- Actual subcooler circuit superheat
- Target subcooler circuit superheat
- Main EEV position
- Subcooling EEV position
- Inverter compressor current transducer value
- Outdoor air temperature
- Actual high pressure/saturation temperature
- Actual low pressure/saturation temperature
- Suction temperature
- Inverter compressor discharge temperature
- Front outdoor coil pipe temperature
- Back outdoor coil pipe temperature
- Liquid line pipe temperature
- Subcooler inlet temperature
- Subcooler outlet temperature
- Average indoor unit (IDU) pipe temperature
- Inverter compressor operation indicator light
- Liquid injection valves' operation indicator lights
- Hot gas bypass valve operation indicator light
- Four-way reversing valve operation indicator light
- Pressure graph showing actual low pressure and high pressure levels
- Error code display
- Operating mode indicator
- Target high pressure
- Target low pressure
- PCB (printed circuit board) version
- Software version
- Installer name
- Model number of IDUs
- Site name
- Total number of connected IDUs

Figure 101: MV Real-time Data Screen



- Communication indicators
- IDU capacity
- IDU operating mode
- IDU fan speed
- IDU EEV position
- IDU room temperature
- IDU inlet pipe temperature
- IDU outlet pipe temperature
- IDU error code

Additional screens can be accessed by tabs on the main screen. Additional screens include the following:

1. Cycleview: Graphic of internal components including:
  - Compressors showing actual speeds
  - EEVs
  - IDUs
  - Temperature and pressure sensors
  - Four-way reversing valve
2. Graph: Full screen graph of actual high and low pressures and high and low pressure limits. A sliding bar enables user to go back in time and view data.
3. Control FTN: Enables user to turn on IDUs in 1.8 °F increments.
4. Useful Tab
  - Unit Conversion: Converts metric values to imperial values.

Figure 102: MV Cycleview

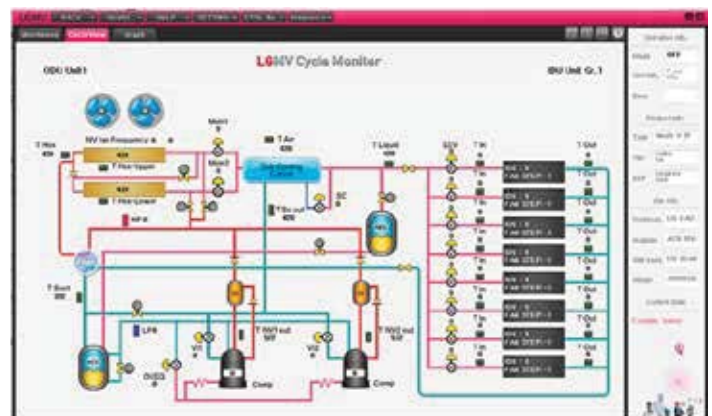

**Note:**

Images on these pages are examples of LGMV screenshots. Actual images may differ depending on the version of the software and the unit installed.

LG Monitoring View (LGMV) Diagnostic Software and Cable - Continued

5. Data

- Data Saving Start: Recording of real time data to a separate file created to be stored on the user's computer.
- Data Loading Start: Recorded data from a saved ".CSV" file can be loaded to create an LGMV session.

6. Monitoring

- Electrical: The lower half of main screen is changed to show Inverter Compressor Amps, Volts, Power Hz, Inverter control board fan Hz.

Figure 103: MV Control Indoor Units Screen



Error Codes

LGMV software helps the service technician or commissioning agent to troubleshoot system operation issues by displaying malfunction codes. These error codes can be seen on the main screen of the LGMV software program. For an overview of Multi F / Multi F MAX system error codes, see Error Codes section. For detailed information on how to troubleshoot individual error codes, see the Multi F / Multi F MAX Service Manual.

Figure 104: Error Code Screen



The software is available in a high version with all of the features listed above. The low version has all features as the high version without Target High Pressure and Target Low Pressure values shown on main screen.

In lieu of connecting to the outdoor unit, user has the option to connect to IDU with the use of a USB to RS-485 connector kit. When connected through IDU, user will not be able to record data.

This software can be used to both commission new systems and troubleshoot existing systems. LGMV data can be recorded to a ".CSV" file and emailed to an LG representative to assist with diagnostic evaluations.

Recommended Minimum PC Configuration:

- CPU: Pentium® IV 1.6 GHz
- Main Memory: 1G
- Operating System: Windows® XP/Vista/7 32 bit (recommended), 64 bit
- Hard Disk: 600 MB when operating
- MS Office 2003, 2007 (recommended) for select reporting functions

Note:

Images on these pages are examples of LGMV screenshots. Actual images may differ depending on the version of the software and the units installed.

# TROUBLESHOOTING

## Self Diagnosis Functions

MULTI F  
MULTI F MAX

### LG SIMS

The SIMS WLAN module and the smart phone app together provide monitoring and troubleshooting capability for LG Multi F / Multi F MAX systems. SIMS functions only with LG Duct Free products.

SIMS can display and graph operational data for the air conditioner system including the indoor unit and the outdoor unit. SIMS also displays error codes and a troubleshooting guide. A full copy of the LG SIMS Smart Inverter Monitoring System User's Manual is available on the www.lghvac.com website.

To use SIMS you must be a trained HVAC service technician familiar with variable refrigerant flow (VRF) systems in general and with LG's Duct Free System products. You should understand the inverter air conditioning operation cycle, the meaning of the data displayed by SIMS, and how to use the data to troubleshoot the system.

Figure 106 shows a Multi F configuration used with the SIMS module and app. LG SIMS can also be used with Single Zone one-to-one configurations such as the Single Zone Wall Mount systems.

Figure 105: LG SIMS App and WLAN Module



Figure 106: SIMS WLAN Module to Typical DFS System



### ⚠ WARNING

High voltages capable of causing death are used in this equipment. Outdoor unit power remains connected during this procedure. Take extreme caution not to touch electrical components or connections. Failure to observe this warning can result in death or severe injury.

### Note:

- The Duct Free System air conditioning system must run for at least 15–20 minutes before data collected by SIMS 2.0 is valid for troubleshooting.
- The free SIMS app must be correctly installed on your smart phone before using SIMS.
- Some ODUs have an LGMV extension cable accessed by removing the side handle cover. If the ODU does not have this extension cable, access the LGMV connector by removing the top cover of the ODU.

### SIMS App Main Info Screen

The main screen is the first screen displayed after wireless connection is established. Tap the Main Info tab to display current readings regarding your indoor and outdoor unit(s). The Operational Info area of the screen will show active functions or modes by illuminating the light to the right of the function.

Additional Help information can be accessed by tapping the Help Menu buttons at the bottom of this screen.

Figure 107: SIMS App Main Info Screen

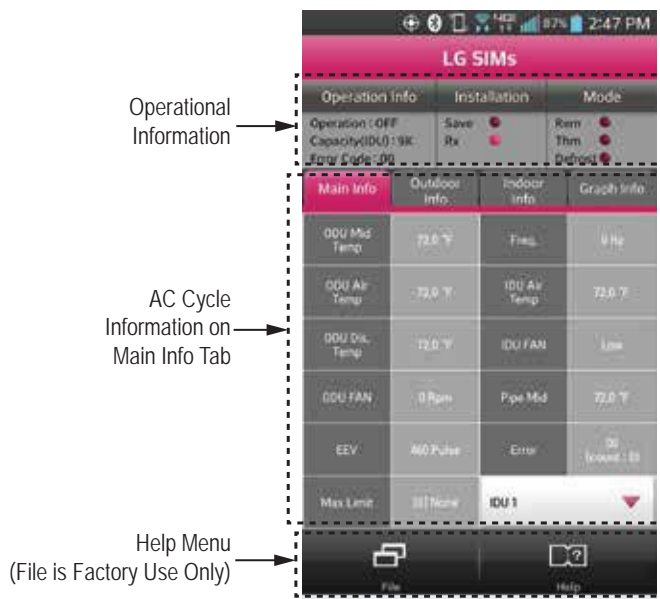

SIMs App Screens



Outdoor Info/Component Screen

Displays the following information:

- Frequency
- FAN1 RPM
- FAN2 RPM
- DC Link
- Current
- Voltage
- EEV Mode
- Restart Timer
- Comp Mode
- EEV

Outdoor Info/Temperature Screen

Displays the following information:

- Inv TD
- Suction
- Discharge
- Cond Mid
- Cond Out
- Heatsink
- Air Temp

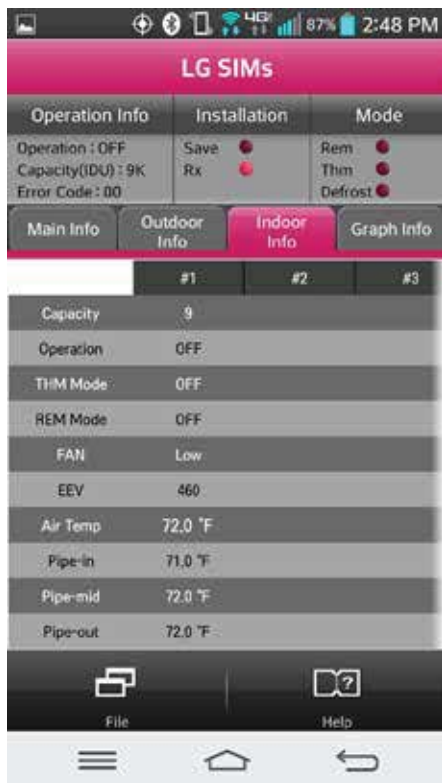

Indoor Info Tab

Displays the following information:

- Frequency
- Operation
- THM Mode
- REM Mode
- FAN
- EEV
- Air Temp
- Pipe-in
- Pipe-mid
- Pipe-out

Graph Info Tab

This tab, has three sub sections:

- IDU - Indoor Unit Temperature graph. Displays IDU information in graph format. Information displayed is for the IDU # selected on the Main screen.
- ODU - Outdoor Unit Temperature and Frequency graph. Displays ODU information in graph format.
- ODU Electric - Outdoor Unit Electric data graph is displayed.

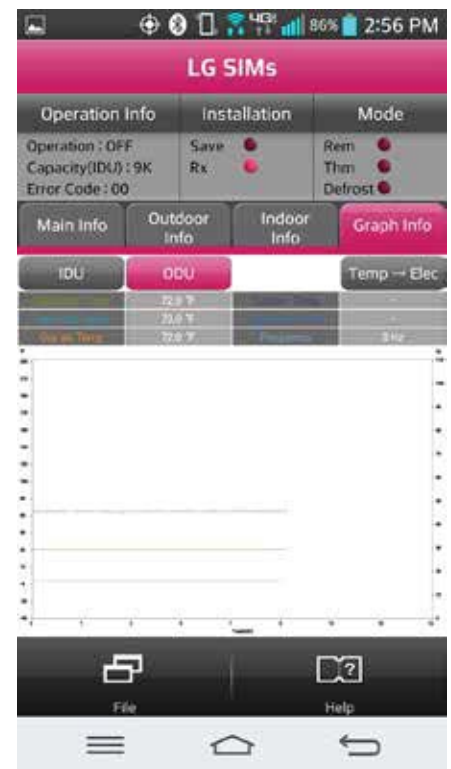

### Troubleshooting Using Error Codes

Refer to Tables 44 and 45 for error codes that are generated from the indoor and outdoor units. These codes indicate different types of unit failures, assist in self-diagnosis, are the most common that will manifest through these units. Error codes are displayed on indoor unit LEDs, wired remote controllers, the outdoor unit PCB, and through LG Monitoring View (LGMV) diagnostic software.

Systems may generate additional codes not listed here. Contact LG Support if these types of errors are seen and a simple power down and boot up has not corrected the issue. Do not attempt to fix the system yourself.

- If two or more errors occur simultaneously, the highest error code number is displayed first.
- After error is resolved, the error code does not display.

### Decoding the Error Display

See images and table below for indoor unit error codes, location of LEDs, and operation status.

The first and second number on the LED indicates error number. Example: 21 = LED1 (Red light) 2x blink, LED2 (Green light) 1x blink.

### Error Code Nomenclature Definitions

- MICOM: Non-volatile memory chip where unit setup information is stored.
- EPROM: Non-volatile memory chip where device identification, size, and factory defined default component operating parameters are stored.

Figure 108: Standard Wall-Mounted Indoor Unit LEDs.

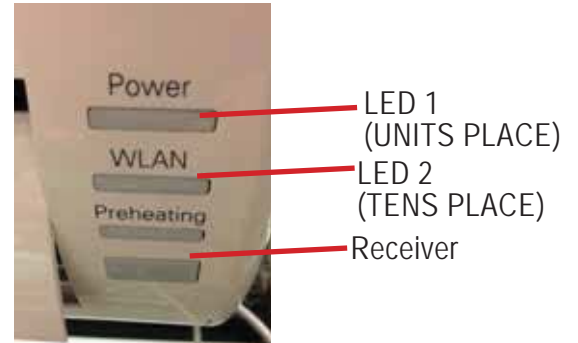

Figure 109: Art Cool Mirror Wall-Mounted Indoor Unit LEDs.

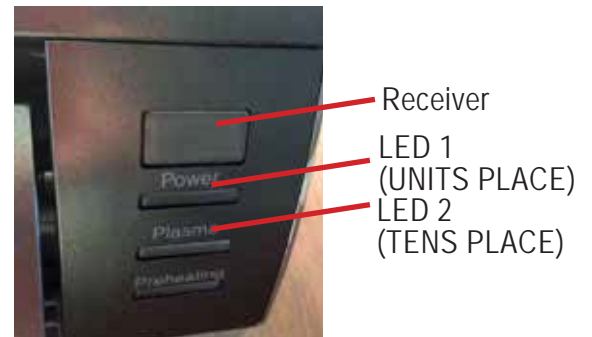

Figure 110: Ceiling Cassette Indoor Unit LEDs.

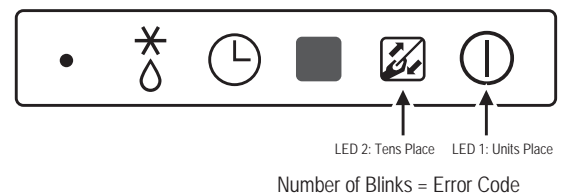

Table 44: Indoor Unit Error Codes.

Error Code	Description	Indoor Unit Operation Status
00	No error	ON
01	Indoor unit room temperature sensor error	OFF
02	Indoor unit inlet pipe sensor error	OFF
03	Controller error	OFF
04	Drain pump error (optional)	OFF
05	Communication error between indoor unit and outdoor units	OFF
06	Indoor unit outlet pipe sensor error	OFF
07	Different mode operation error	OFF
09	Indoor unit EPROM error	OFF
10	Indoor unit BLDC motor fan lock	OFF

Table 45: Outdoor Unit Error Codes.

Error Code	Description	No. of Times Outdoor Unit LEDs Blink		Outdoor Operation Status
		LED01 (Red)	LED02 (Green)	
21	DC Peak (IPM Fault); Compressor DC voltage was too high	2X	1X	OFF
22	Current Transformer2 (CT2) error; Alternating current (AC) input too high	2X	2X	OFF
23	DC Link Low Voltage (DC Link Voltage is <140VDC)	2X	3X	OFF
	DC Link High Voltage (DC Link Voltage is >420VDC)			
25	AC Low / High Voltage	2X	5X	OFF
26	DC Compressor Position Error (Compressor failed to start properly)	2X	6X	OFF
27	PSC / PFC Fault; Input current to inverter compressor PCB is too high	2X	7X	OFF
29	Current to inverter compressor is too high	2X	9X	OFF
32	Inverter compressor discharge pipe (D-Pipe) temperature is too high	3X	2X	OFF
35	Low Pressure Error; Pressure dropped below recommended limits	3X	5X	OFF
39	Communication Error between PFC MICOM and Inverter MICOM	3X	9X	OFF
40	CT Sensor Error; Thermistor is disconnected or has shorted out	4X	-	OFF
41	Inverter compressor discharge pipe (D-Pipe) sensor is disconnected or has shorted out	4X	1X	OFF
43	High pressure sensor is disconnected or has shorted out	4X	3X	OFF
44	Outdoor air sensor is disconnected or has shorted out	4X	4X	OFF
45	Mid-pipe thermistor of outdoor unit condenser is disconnected or has shorted out	4X	5X	OFF
46	Outdoor unit suction piping thermistor is disconnected or has shorted out	4X	6X	OFF
48	Outlet piping (liquid) of condenser is disconnected or has shorted out	4X	8X	OFF
51	Combination ratio (capacity) is out of range; Total nominal indoor unit capacity is <50% or >130% of the outdoor unit capacity	5X	1X	OFF
53	Communication failure between outdoor unit and indoor unit(s)	5X	3X	OFF
54	Outdoor unit is not wired properly (ex: reversed phase)	5X	4X	OFF
60	Outdoor unit printed circuit board (PCB) EPROM check sum error	6X	-	OFF
61	Condenser coil thermistor temperature is too high	6X	1X	OFF
62	Outdoor unit inverter compressor PCB heat sink temperature is too high	6X	2X	OFF
65	Heat sink thermistor is disconnected or has shorted out	6X	5X	OFF
67	Outdoor unit brushless direct current (BLDC) fan motor lock error	6X	7X	OFF
73	Outdoor unit PFC overcurrent (peak) error	7X	3X	OFF

## Cautions for Refrigerant Leaks / Introduction

ASHRAE Standards 15 and 34 offer guidelines that address refrigerant safety and the maximum allowable concentration of refrigerant in an occupied space. Refrigerant will dissipate into the atmosphere, but a certain volume of air is required for this to occur safely. For R410A refrigerant, the maximum allowable concentration is 0.026 lbs./ft<sup>3</sup> per 1,000 ft<sup>3</sup> of air in an occupied space. Buildings with twenty-four (24) hour occupancy allow half of that concentration.<sup>1</sup>

ASHRAE Standards 15 and 34 assume that if a system develops a leak, its entire refrigerant charge will dump into the area where the leak occurs. To meet ASHRAE Standards 15 and 34, calculate the refrigerant concentration that may occur in the smallest room volume on the system, and compare the results to the maximum allowable concentration number (see below for information on how to calculate the refrigerant concentration).<sup>1</sup> Also consult state and local codes in regards to refrigerant safety.

### ⚠ WARNING

Verify the maximum refrigerant concentration level in the space where the indoor unit will be mounted meets the concentration limit for the application. If the refrigerant leaks and safety limits are exceeded, it could result in personal injuries or death from oxygen depletion.

### Note:

Take appropriate actions at the end of HVAC equipment life to recover, recycle, reclaim or destroy R410A refrigerant according to applicable US EPA rules.

To calculate the potential refrigerant concentration level (RCL):

1. Measure the occupied space dimensions (in feet).
2. Calculate the cubic foot volume of air in the smallest occupied space. (To obtain a detailed overview of the RCL, perform the same calculations to the second smallest zone, the third smallest zone until the RCL is obtained for all zones. Also, pay special attention to areas such as basements, etc., where refrigerant cannot dissipate easily.)
3. Divide the refrigerant charge of the Multi Zone system serving the area in pounds by the results of step 1.
4. If the calculation indicates that the potential refrigerant concentration level is higher than the allowed RCL, increase the cubic volume of the smallest occupied space or modify the piping system design.
5. The allowable RCL limit for most applications must be equal to or less than 0.026 lbs./ft<sup>3</sup>. However, in special occupied spaces, such as hospitals and nursing homes, where occupants may have limited mobility, the allowable RCL limit is cut in half. See ASHRAE Standard 34 and local codes for detailed information.<sup>1</sup>

Figure 111: Example of R410A Refrigerant Leak Location.

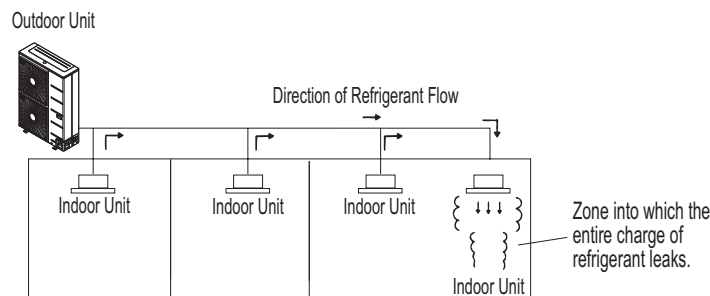

### Refrigerant Concentration Limit (RCL) Calculations

To calculate total refrigerant amount per system:

<b>Amount of Factory-Charged Refrigerant per Outdoor Unit</b>	<b>+</b>	<b>Amount of Additional Refrigerant Trim Charge</b>	<b>=</b>	<b>Total System Refrigerant Charge</b>
---	----------	---	----------	--

$$\text{RCL (lbs./ft}^3\text{)} = \frac{\text{Total System Refrigerant Charge (lbs.)}}{\text{Volume of Smallest Occupied Space (ft}^3\text{)}}$$

<sup>1</sup>American Society of Heating, Refrigeration and Air Conditioning Engineers, Inc. (ASHRAE). Atlanta, GA. ASHRAE, Inc. Information about ASHRAE Standard 15 / 34 and addenda current as of the date of this publication.

To determine the volume of an occupied space, the designer must also determine which ones are connected, not connected, or ventilated (refer to Standard 34).

If the calculated RCL is above the allowable limit, there are two primary methods used to lower the RCL:

1. Increase the volume of the occupied space.
2. Decrease the size of the refrigerant charge.

Per Standard 34-2007, acceptable methods used to increase the volume of an occupied space include:

- Install transfer ducts between rooms.
- Undercut and overcut doors (partitions  $\leq 0.15\%$  of cubic volume of space within a zone).
- Add an opening without a door (partitions  $\leq 0.15\%$  of cubic volume of space within a zone).
- Include ventilation grilles in doors; include ventilation inlets / outlets (partitions  $\leq 0.15\%$  of cubic volume of space within a zone).
- Include the area above the ceiling as part of the return or supply air path (partitions  $\leq 0.15\%$  of cubic volume of space within a zone).
- Install a mechanical ventilator linked to a gas leak detector.
- Change the indoor unit type (wall mounted to ceiling cassette) / position.

Figure 112: Examples of Zones.

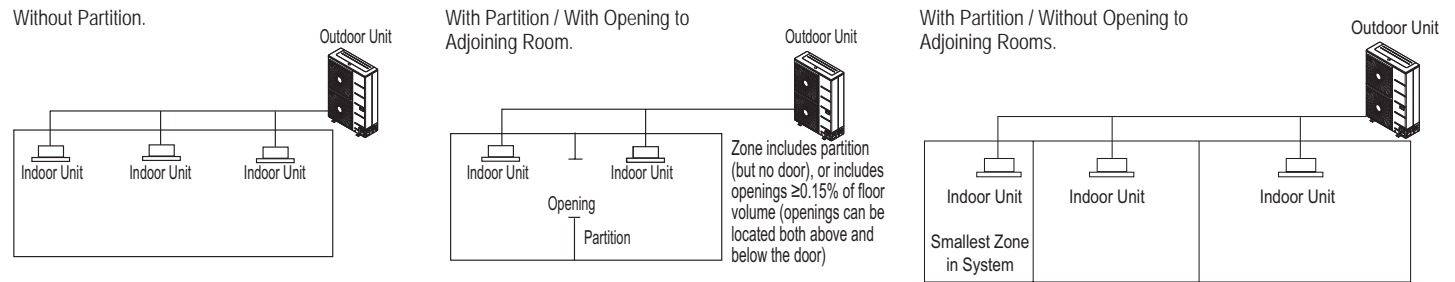
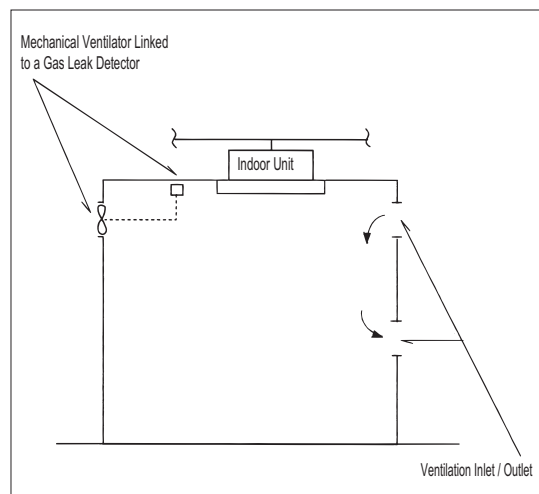

Figure 113: Examples of Acceptable Ventilation Methods.





**Major Component Rough-In**

Description	Check
All Multi F / Multi F MAX outdoor units were connected properly per local code and the product installation procedures.	
All literature and bagged accessories have been removed from the fan discharge.	
Indoor units and branch distribution unit(s) (Multi F MAX only) are installed, properly supported, and located indoors in a non-corrosive environment.	
Multi F / Multi F MAX gravity condensate drain line was connected and routed where it properly drains away or, if installed in a mechanical room, was connected and properly routed to a drain terminal.	

**Piping and Insulation**

Description	Check
Copper	
Over 5/8 inches—Rigid ACR only.	
5/8 inches and under—Can use soft ACR.	
15% silver brazing material only.	
All refrigerant pipes and valves were insulated separately. Insulation butts up against the walls of the indoor units. No gaps or cracks. Insulation was not compressed at clamps and hangers.	
LG Y-branches were used per manufacturer’s recommendations.	
(Optional) Full port ball valves for all indoor units. (Schrader between the valve body and the indoor units.)	
Condensate piping installed on indoor units—material used is acceptable under local code. Insulated as necessary to prevent condensation.	

**Brazing Practices**

Description	Check
Medical grade (there are 4 available) dry nitrogen for purging during brazing was used (constant 3 psi while brazing).	

**Installation**

(For more information on any procedure, refer to the detail provided in the Indoor Unit Installation Manuals.)

**Refrigerant Piping**

Description	Check
Have in possession a copy of the “As-Designed” LATS Multi F piping tree diagram. BEFORE ANY FIELD PIPE SIZE OR LENGTH CHANGES ARE MADE, PROPOSED CHANGES MUST BE FORWARDED TO THE DESIGN ENGINEER SO THAT THEY CAN INPUT THE CHANGES INTO LATS and RE-ISSUE A NEW LATS PIPING TREE DIAGRAM. Installer must receive change authorization from the design engineer, because any change made requires the review of the entire tree diagram and verification that the change did not impact the size of piping segments in other parts of the system.	
All pipe materials were properly stored, capped, and clean. All burrs were removed after cutting and pipe ends were reamed before brazing.	
During refrigerant pipe installation, for each segment of pipe, a record was made of the pipe length (including expansion loops, offsets, double-back sections), and sizes, as well as the quantity and type of elbows used.	
All long runs of straight pipe were provided with expansion loops.	
Ensure Y-branches are installed with no more than $\pm 5^\circ$ of horizontal.	
Ensure Y-branches are installed with no more than $\pm 3^\circ$ of vertical.	
A torque wrench and backup wrench were used to tighten all flare connections.	
The back side of all flares were lubricated with a small drop of PVE refrigeration oil before tightening flare fittings.	
Ensure all field made flares are $45^\circ$ . Use factory-supplied flare nuts only.	
Pipe segments were properly supported and all wall penetrations were sleeved.	
Pipe insulation was not compressed at any point.	
Y-branches were properly supported per details provided in the installation manual.	
Ensure Y-branches are installed in the correct direction. Flow is always from the single end to the double end.	
No oil traps, solenoid valves, sight glasses, filter driers, or any other unauthorized refrigerant specialties were present.	
(Optional) R410A rated full port ball valves were used at all indoor units and wherever appropriate in the refrigerant piping network.	
Best practice including a minimum of 20" of straight pipe was installed between each elbow.	



**Condensate Pump / Drain Installation**

Description	Check
Indoor unit condensate drain pipes were installed correctly.	
All condensate vertical risers are equal to or less than 27-1/2" from the bottom of the indoor unit.	
Indoor units with condensate pumps were level. Units with gravity drains were level or slightly canted toward the drain connection and are supported properly.	
Pumped condensate drain lines were properly connected (do not have traps, and connect to the top surface of the main drain line).	

**Power Wire and Communications Cables**

Description	Check
Power wiring was connected to a single phase 208-230V source.	
Ground wire was installed and properly terminated at the unit.	
The power supplied was clean with voltage fluctuations within specifications. ( $\pm 10\%$ of nameplate).	
Power wiring to the Multi F / Multi F MAX outdoor unit was installed per all local electrical code requirements.	
Power wiring to the indoor units and branch distribution unit(s) (Multi F MAX only) was installed per all local electrical code requirements.	
LG-supplied cable was used between each indoor unit and its zone controller. No cables were spliced and no wire caps are present.	
Communication type RS-485-BUS type.	
Communications/power were a minimum of 18-AWG, four (4) conductor, stranded, shielded or unshielded, with insulation material per local code. If shielded, must be ground to outdoor unit only. Cable segment shields were tied together.	
Used appropriate crimping tool to attach ring or spade terminals at all power wiring and control cable terminations.	
Power and control wires were run in the same conduit (ODU to IDU only) as provided in the product installation manual. Power to ODU and power/communications to IDU cannot be run in the same conduit and must be separated per manufacturer's guidelines.	



**Major Component Rough-In**

**Piping and Insulation**

**Brazing Practices**



## Installation—Refrigerant Piping

## Installation—Branch Distribution Unit (Multi F MAX Systems Only)

## Installation—Condensate Pump / Drain Installation

## Installation—Power Wire and Communications Cables



LG Multi F outdoor units ship from the factory with a charge of R410A refrigerant. A trim charge may need to be added to take into account additional piping length.

To determine the additional refrigerant that is needed, apply the formula below, and record the results. If the total additional refrigerant charge value is a negative number, then an additional trim charge does not need to be added to the system.

### Multi F Outdoor Unit Factory Charge

Outdoor Unit	Factory Charge lbs. of R410A
LMU18CHV	3.96
LMU24CHV	3.96
LMU30CHV	6.18
LMU36CHV	6.18

### Multi F Outdoor Unit Additional Refrigerant Charge Formula

$$\begin{aligned} \text{Additional charge (lbs.)} &= (\text{Installed Length of Branch [A]} - \text{Chargeless Pipe Length [L]}) \times a \\ &+ (\text{Installed Length of Branch [B]} - \text{Chargeless Pipe Length [L]}) \times a \\ &+ (\text{Installed Length of Branch [C]} - \text{Chargeless Pipe Length [L]}) \times a \\ &+ (\text{Installed Length of Branch [D]} - \text{Chargeless Pipe Length [L]}) \times a \\ &- \text{CF (Correction Factor)} \times 5.29 \end{aligned}$$

**Note:**

- Number of installed length of branches depends on the specifications of the outdoor unit model.
- CF = Maximum number of connectible indoor units – Total number of connected indoor units.

### Multi F Outdoor Unit Piping Specifications

Multi F Outdoor Unit Model	Min. to Max. Piping Length for One Branch (ft.)	Max. Total System Piping Length (ft.)	Chargeless Pipe Length per Branch (L) (ft.)	Additional Charge Needed (a) (oz./ft.)
LMU18CHV	10 to 82	164	24.6	0.22
LMU24CHV	10 to 82	246.1	24.6	0.22
LMU30CHV	10 to 82	246.1	24.6	0.22
LMU36CHV	10 to 82	246.1	24.6	0.22

## Multi F Refrigerant Charge Calculations

$$\begin{aligned} &(\text{_____}[A] - 24.6) \times 0.22 && (\text{_____}) \\ + &(\text{_____}[B] - 24.6) \times 0.22 && + (\text{_____}) \\ + &(\text{_____}[C] - 24.6) \times 0.22 && + (\text{_____}) \\ + &(\text{_____}[D] - 24.6) \times 0.22 && + (\text{_____}) \\ - &\text{_____CF} \times 5.29 && - (\text{_____}) \\ = &\text{_____ Additional Charge (lbs.)} \end{aligned}$$

# MULTI F MULTI F MAX

# MULTI F MAX REFRIGERANT CHARGE WORKSHEET



LG Multi F MAX outdoor units ship from the factory with a charge of R410A refrigerant. A trim charge may need to be added to take into account additional piping length.

To determine the additional refrigerant that is needed, apply the formula below, and record the results. If the total additional refrigerant charge value is a negative number, then an additional trim charge does not need to be added to the system.

### Multi F MAX Outdoor Unit Factory Charge

Outdoor Unit	Factory Charge lbs. of R410A
LMU480HV	9.7
LMU540HV	9.7
LMU600HV	12.3

$$\begin{aligned} \text{Additional charge (lbs.)} &= (\text{Total Main Piping Length [A]} - \text{Chargeless Pipe Length of Main Pipe [L]}) \times a \\ &+ (\text{Installed Length of Branch [B1]} - \text{Chargeless Pipe Length [B]}) \times b \\ &+ (\text{Installed Length of Branch [B2]} - \text{Chargeless Pipe Length [B]}) \times b \\ &+ (\text{Installed Length of Branch [B3]} - \text{Chargeless Pipe Length [B]}) \times b \dots \\ &- \text{CF (Correction Factor)} \times 3.53 \end{aligned}$$

**Note:**

- Number of installed length of branches depends on system specifications.
- CF = Maximum number of connectible indoor units – Total number of connected indoor units

### Multi F MAX Outdoor Unit Piping Specifications

Outdoor Unit Model	Main Piping Length		Branch Piping Length	
	Chargeless Pipe Length of Main Pipe (L) (ft.)	Additional Charge Needed (a) (oz./ft.)	Chargeless Pipe Length per Branch Pipe (B) (ft.)	Additional Charge Needed (b) (oz./ft.)
LMU480HV	16.4	0.54	16.4	0.22
LMU540HV	16.4	0.54	16.4	0.22
LMU600HV	16.4	0.54	16.4	0.22

### Multi F MAX Refrigerant Charge Calculations

$$\begin{aligned} &(\text{_____ [A]} - 16.4) \times 0.54 && (\text{_____}) \\ + &(\text{_____ [B1]} - 16.4) \times 0.22 && + (\text{_____}) \\ + &(\text{_____ [B2]} - 16.4) \times 0.22 && + (\text{_____}) \\ + &(\text{_____ [B3]} - 16.4) \times 0.22 && + (\text{_____}) \\ + &(\text{_____ [B4]} - 16.4) \times 0.22 && + (\text{_____}) \\ + &(\text{_____ [B5]} - 16.4) \times 0.22 && + (\text{_____}) \\ + &(\text{_____ [B6]} - 16.4) \times 0.22 && + (\text{_____}) \\ + &(\text{_____ [B7]} - 16.4) \times 0.22 && + (\text{_____}) \\ + &(\text{_____ [B8]} - 16.4) \times 0.22 && + (\text{_____}) \\ - &\text{_____ CF} \times 3.53 && - (\text{_____}) \\ &&& = \text{_____ Additional Charge (lbs.)} \end{aligned}$$

*Inverter*



Refer to Service Manuals posted on [www.lghvac.com](http://www.lghvac.com) for a full description of all error codes and work-arounds.



LG Electronics, U.S.A., Inc.  
Commercial Air Conditioning Division  
4300 North Point Parkway  
Alpharetta, Georgia 30022  
[www.lg-vrf.com](http://www.lg-vrf.com)

LG Electronics Products Support  
1-888-865-3026 USA  
Follow the prompts for HVAC products.

IM\_MultiF\_ODU\_03\_17  
Supersedes: IM\_MultiF\_ODU\_11\_16  
IM\_MultiF\_ODU\_4\_16  
IM\_MultiF\_ODU\_11\_15



# MULTI F MULTI F MAX WITH LGRED<sup>o</sup>

## HEAT PUMP OUTDOOR UNIT INSTALLATION MANUAL

**Multi-Zone Heat Pump Systems  
1.5 to 4.0 Tons**

Dual-, Tri-, and Quad-Zone  
Multi F



Up to Eight Zones  
Multi F MAX



## **PROPRIETARY DATA NOTICE**

**This document, as well as all reports, illustrations, data, information, and other materials are the property of LG Electronics U.S.A., Inc., and are disclosed by LG Electronics U.S.A., Inc. only in confidence.**

**⊘ Do not throw away, destroy, or lose this manual.  
Please read carefully and store in a safe place for future reference.  
Content familiarity is required for proper installation.**

The instructions included in this manual must be followed to prevent product malfunction, property damage, injury, or death to the user or other people. Incorrect operation due to ignoring any instructions will cause harm or damage. The level of seriousness is classified by the symbols described by the summary list of safety precautions on page 4.

**For more technical materials such as submittals, catalogs, engineering, owner's, best practices, building ventilation guide, and service manuals, visit [www.lghvac.com](http://www.lghvac.com).**

For continual product development, LG Electronics U.S.A., Inc. reserves the right to change specifications without notice.

© LG Electronics U.S.A., Inc.

---







---

<b>Safety Instructions</b> .....	<b>4-7</b>
<b>Nomenclature</b> .....	<b>8</b>
<b>General Data</b> .....	<b>9-16</b>
<b>Installation</b> .....	<b>17-30</b>
<i>Transporting / Lifting</i> .....	17
<i>Placement Considerations</i> .....	18-27
<i>Mounting / Anchoring</i> .....	28-30
<b>General Refrigerant Piping System Information</b> .....	<b>31-45</b>
<i>LG Air Conditioner Technical Solution (LATS)</i> .....	31-32
<i>Refrigerant Safety Standards / Device</i>	
<i>Connection Limitations</i> .....	33-34
<i>Selecting Copper Piping</i> .....	35
<i>Copper Expansion and Contraction</i> .....	36-38
<i>Piping Handling</i> .....	39
<i>Refrigerant System Engineering</i> .....	40-43
<i>Flaring and Brazing Procedures</i> .....	44-45
<b>Refrigerant Piping System Installation</b> .....	<b>46-54</b>
<b>Refrigerant Piping Insulation</b> .....	<b>55-57</b>
<b>Electrical System Installation</b> .....	<b>58-71</b>
<i>General Information</i> .....	58
<i>Connections and Specifications</i> .....	59-61
<i>Installation</i> .....	62-71
<b>Final Installation Procedures</b> .....	<b>72-88</b>
<i>Triple Leak / Pressure Test</i> .....	72-73
<i>Deep Evacuation Test</i> .....	73-74
<i>Triple Evacuation Test</i> .....	74-75
<i>Refrigerant Charge</i> .....	76-78
<i>Cautions for Refrigerant Leaks</i> .....	79-80
<i>Test Run</i> .....	81
<i>DIP Switch Settings for Optional Modes</i> .....	82-88
<b>Error Codes</b> .....	<b>89-91</b>
<b>LG Monitoring View (LGMV) Diagnostic Software</b> .....	<b>92-93</b>
<b>Maintenance Recommendations</b> .....	<b>94</b>
<b>Installation Checklists and Worksheets</b> .....	<b>95-100</b>

The instructions below must be followed to prevent product malfunction, property damage, injury or death to the user or other people. Incorrect operation due to ignoring any instructions will cause harm or damage. The level of seriousness is classified by the symbols described below.

## TABLE OF SYMBOLS

 <b>DANGER</b>	<i>This symbol indicates an imminently hazardous situation which, if not avoided, will result in death or serious injury.</i>
 <b>WARNING</b>	<i>This symbol indicates a potentially hazardous situation which, if not avoided, could result in death or serious injury.</i>
 <b>CAUTION</b>	<i>This symbol indicates a potentially hazardous situation which, if not avoided, may result in minor or moderate injury.</i>
<b>Note:</b>	<i>This symbol indicates situations that may result in equipment or property damage accidents only.</i>
	<i>This symbol indicates an action must not be completed.</i>

## Installation

### DANGER

 **Do not store or use flammable gas or combustibles near the unit.**  
*There is risk of fire, explosion, and physical injury or death.*

 **Do not supply power to the unit until all wiring and piping are completed or reconnected and checked.**  
*There is risk of physical injury or death due to electric shock.*

### WARNING

 **Do not install or remove the unit by yourself (end user). Ask the dealer or a trained technician to install the unit.**  
*Improper installation by the user will result in fire, explosion, electric shock, physical injury or death.*

**For replacement of an installed unit, always contact an LG trained service provider.**  
*There is risk of fire, electric shock, explosion, and physical injury or death.*

**Wear protective gloves when handling equipment. Sharp edges will cause personal injury.**

 **Do not change the settings of the protection devices.**  
*If the protection devices have been bypassed or is forced to operate improperly, or parts other than those specified by LG are used, there is risk of fire, electric shock, explosion, and physical injury or death.*

**Replace all control box and panel covers.**  
*If cover panels are not installed securely, dust, water and animals will enter the outdoor unit, causing fire, electric shock, and physical injury or death.*

**Always check for system refrigerant leaks after the unit has been installed or serviced.**  
*Exposure to high concentration levels of refrigerant gas will lead to illness or death.*

**Periodically check that the outdoor frame is not damaged.**  
*There is a risk of explosion, physical injury, or death.*

**If the air conditioner is installed in a small space, take measures to prevent the refrigerant concentration from exceeding safety limits in the event of a refrigerant leak.**  
*Consult the latest edition of ASHRAE (American Society of Heating, Refrigerating, and Air Conditioning Engineers) Standard 15. If the refrigerant leaks and safety limits are exceeded, it could result in personal injuries or death from oxygen depletion.*

**The branch distribution (BD) unit must be installed indoors;**  
 **do not install the BD unit in a highly humid environment.**  
*There is risk of physical injury or death due to electric shock.*

### **Dispose the packing materials safely.**

- *Packing materials, such as nails and other metal or wooden parts, will cause puncture wounds or other injuries.*
- *Tear apart and throw away plastic packaging bags so that children will not play with them and risk suffocation and death.*

**Install the unit considering the potential for strong winds or earthquakes.**  
*Improper installation will cause the unit to fall over, resulting in physical injury or death.*

**Install the unit in a safe location where nobody can step, fall onto it, or place objects on it.**  **Do not install the unit on a defective stand.**  
*It will result in an accident that causes physical injury or death.*

---

---

## Installation, continued

### ⚠ WARNING

**Properly insulate all cold surfaces to prevent “sweating.”**

*Cold surfaces such as uninsulated piping can generate condensate that could drip, causing a slippery surface that creates a risk of slipping, falling, and personal injury.*

---

### ⚠ CAUTION

**Be very careful when transporting the product. There is a risk of the product falling and causing physical injury.**

- Use appropriate moving equipment to transport each frame; ensure the equipment is capable of supporting the weights listed.
- Some products use polypropylene bands for packaging. Ⓣ Do not use polypropylene bands to lift the unit.
- Support the outdoor unit a minimum of four points to avoid slippage from rigging apparatus.

---

## Note:

LG Electronics U.S.A., Inc., is not responsible for any piping calculations, refrigerant leaks, degradation of performance, or any other potential problems or damages as a result of interconnecting piping, their joint connections, isolation valves, introduced debris inside the piping system, or other problems caused by the interconnecting piping system.

Ⓣ Do not install the product where it is exposed directly to ocean winds.

*Sea salt in the air will cause the product to corrode. Corrosion, particularly on the condenser and evaporator fins, could cause product malfunction or inefficient operation.*

**When installing the outdoor unit in a low-lying area, or a location that is not level, use a raised concrete pad or concrete blocks to provide a solid, level foundation.**

*This prevents water damage and abnormal vibration.*

**Properly insulate all cold surfaces to prevent “sweating.”**

*Cold surfaces such as uninsulated piping can generate condensate that will drip and cause water damage to walls.*

**Always check for system refrigerant leaks after the unit has been installed or serviced.**

*Low refrigerant levels will cause product failure.*

**The branch distribution (BD) unit must be installed indoors;**

Ⓣ Do not install the BD box in a highly humid environment. *There is risk of product failure and property damage.*

Ⓣ Do not make refrigerant substitutions. Use R410A only. *If a different refrigerant is used, or air mixes with original refrigerant, the unit will malfunction and be damaged.*

Ⓣ Do not store or use flammable gas / combustibles near the unit.

*There is a risk of product failure.*

Ⓣ Do not use the product for mission critical or special purpose applications such as preserving foods, works of art, or other precision air conditioning applications. The equipment is designed to provide comfort cooling and heating. *There is risk of property damage.*

**Keep the unit upright during installation to avoid vibration or water leakage.**

**When connecting refrigerant tubing, remember to allow for pipe expansion.** *Improper piping will cause refrigerant leaks and system malfunction.*

Ⓣ Do not install the outdoor unit or BD unit in a noise-sensitive area.

**Take appropriate actions at the end of HVAC equipment life to recover, recycle, reclaim or destroy R410A refrigerant according to applicable U.S. Environmental Protection Agency (EPA) rules.**

**Periodically check that the outdoor frame is not damaged.** *There is a risk of equipment damage.*

**Install the unit in a safe location where nobody can step on or fall onto it.** Ⓣ Do not install the unit on a defective stand. *There is a risk of unit and property damage.*

**Install the drain hose to ensure adequate drainage.** *There is a risk of water leakage and property damage.*

## Wiring

### ⚠ DANGER

**High voltage electricity is required to operate this system. Adhere to the NEC code and these instructions when wiring. Improper connections and inadequate grounding can cause accidental injury or death.**

**Always ground the unit following local, state, and NEC codes. There is risk of fire, electric shock, and physical injury or death.**

**Turn the power off at the nearest disconnect before servicing the equipment. Electrical shock can cause physical injury or death.**

**Properly size all circuit breakers or fuses. There is risk of fire, electric shock, explosion, physical injury or death.**

⊘ **Do not share the electrical circuit with other appliances. There is risk of fire, electric shock, and physical injury or death due to heat generation.**

⊘ **Do not use damaged or loose power wiring. ⊘ Do not randomly modify or extend the outdoor unit's power wiring. Ensure that the power wiring will not be pulled nor weight be placed on the power wiring during operation. There is risk of fire, electric shock, and physical injury or death.**

### ⚠ WARNING

**The information contained in this manual is intended for use by an industry-qualified, experienced, certified electrician familiar with the U.S. National Electric Code (NEC) who is equipped with the proper tools and test instruments. Failure to carefully read and follow all instructions in this manual can result in personal injury or death.**

**All electric work must be performed by a licensed electrician and conform to local building codes or, in the absence of local codes, with the National Electrical Code, and the instructions given in this manual. If the power source capacity is inadequate or the electric work is not performed properly, it will result in fire, electric shock, physical injury or death.**

**Refer to local, state, and federal codes, and use power wires of sufficient current capacity and rating. Wires that are too small will generate heat and cause a fire.**

**Secure all field wiring connections with appropriate wire strain relief. Improperly securing wires will create undue stress on equipment power lugs. Inadequate connections will generate heat, cause a fire and physical injury or death.**

**Ensure the system is connected to a dedicated power source that provides adequate power. If the power source capacity is inadequate or the electric work is not performed properly, it will result in fire, electric shock, physical injury or death.**

**Properly tighten all power connections. Loose wiring will overheat at connection points, causing a fire, physical injury or death.**

⊘ **Do not change the settings of the protection devices. If the protection devices have been bypassed or are forced to operate improperly, or parts other than those specified by LG are used, there is risk of fire, electric shock, explosion, and physical injury or death.**

## Note:

⊘ **Do not supply power to the unit until all electrical wiring, controls wiring, piping, installation, and refrigerant system evacuation are completed. System will malfunction.**

**The information contained in this manual is intended for use by an industry-qualified, experienced, certified electrician familiar with the U.S. National Electric Code (NEC) who is equipped with the proper tools and test instruments. Failure to carefully read and follow all instructions in this manual can result in equipment malfunction and / or property damage.**

## Operation

### ⚠ DANGER

⊘ Do not provide power to or operate the unit if it is flooded or submerged.

*There is risk of fire, electric shock, physical injury or death.*

**Use a dedicated breaker for this product.**

*There is risk of fire, electric shock, physical injury or death.*

⊘ Do not operate the disconnect switch with wet hands.

*There is risk of fire, electric shock, physical injury or death.*

**Periodically verify the equipment mounts have not deteriorated.**

*If the base collapses, the unit could fall and cause physical injury or death.*

**Use inert (nitrogen) gas when performing leak tests or air purges. ⊘ Do not use compressed air, oxygen, or flammable gases.**

*Using these substances will cause fire, explosion, and physical injury or death.*

**If refrigerant leaks out, ventilate the area before operating the unit.**

*If the unit is mounted in an enclosed, low-lying, or poorly ventilated area, and the system develops a refrigerant leak, it will cause a fire, electric shock, explosion, physical injury or death.*

### ⚠ WARNING

⊘ Do not allow water, dirt, or animals to enter the unit.

*There is risk of fire, electric shock, physical injury or death.*

⊘ Do not operate the unit with the panel(s) or protective cover(s) removed; keep fingers and clothing away from moving parts.

*The rotating, hot, cold, and high-voltage parts of the unit can cause physical injury or death.*

⊘ Do not touch the refrigerant piping during or after operation.

*It can cause burns or frostbite.*

⊘ Do not open the inlet during operation.

*There is risk of electric shock, physical injury or death.*

### ⚠ CAUTION

**To avoid physical injury, use caution when cleaning or servicing the air conditioner.**

*There is risk of electric shock, physical injury or death.*

## Note:

**Clean up the site after servicing is finished, and check that no metal scraps, screws, or bits of wiring have been left inside or surrounding the unit.**

⊘ Do not use the product for mission critical or special purpose applications such as preserving foods, works of art, or other precision air conditioning applications. The equipment is designed to provide comfort cooling and heating.

*Oil, steam, sulfuric smoke, etc., can significantly reduce the performance of the unit, or damage its parts.*

⊘ Do not block the inlet or outlet.

*Unit will malfunction.*

⊘ Do not allow water, dirt, or animals to enter the unit.

*There is risk of unit failure.*

⊘ Do not open the inlet during operation.

*There is risk of unit failure.*

⊘ Do not operate the unit when the panel(s) or protective cover(s) are removed.

*Non-secured covers can result in product malfunction due to dust or water in the service panel.*

**Periodically verify the equipment mounts have not deteriorated.**

*If the base collapses, the unit could fall and cause property damage or product failure.*

**Use a only soft cloth to clean the air conditioner. ⊘ Do not use wax, thinner, or strong detergents.**

*Strong cleaning products will damage the surface of the air conditioner, or will cause its appearance to deteriorate.*

# UNIT NOMENCLATURE

MULTI F WITH LGRED°  
MULTI F MAX

## Multi-Zone Systems — Indoor Units and Outdoor Units

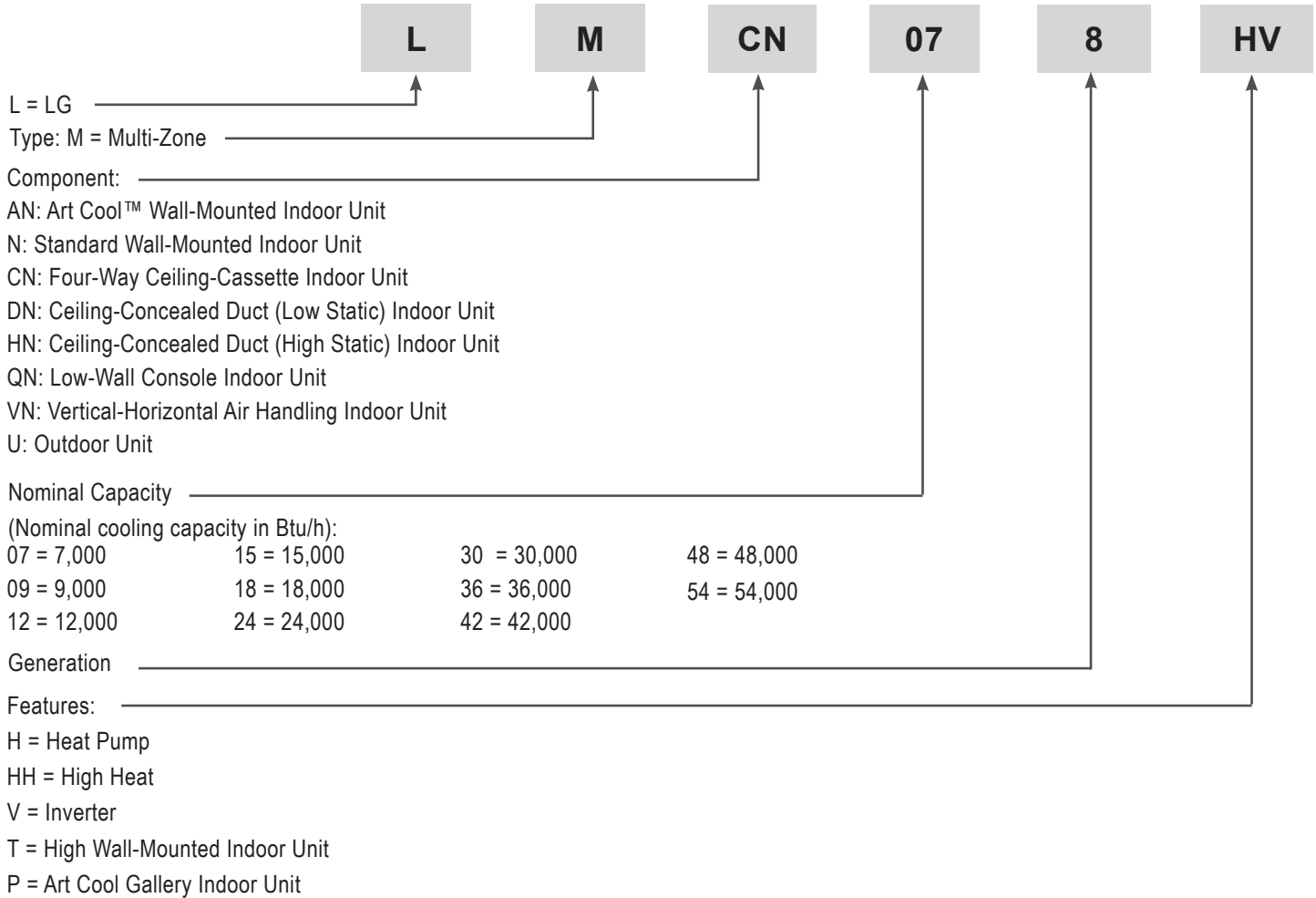

## Branch Distribution Units

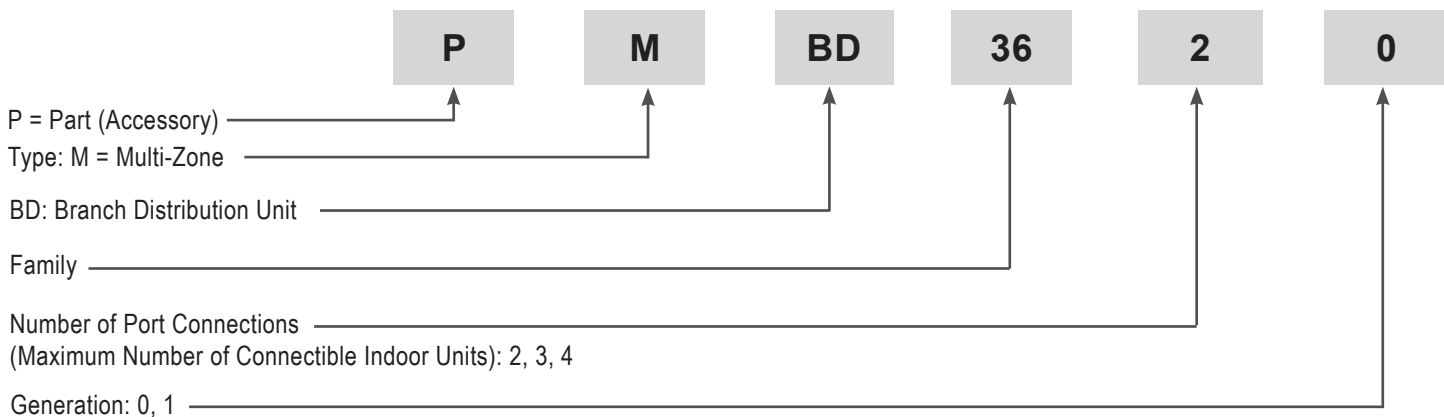

### Note:

- Voltage for all equipment is 208-230V, 60 Hz, 1-phase.
- All indoor units are compatible with wired controllers.
- All outdoor units are LGAP control network compatible with PI-485 V-net Control Integration Board (PMNFP14A1, sold separately).
- Compatible single zone IDU nomenclature is listed in the Single Zone Wall-Mounted IDU Engineering Manual.

Table 1: Multi F with LGRED Outdoor Unit Specifications.

Model Number	LMU180HHV	LMU240HHV	LMU300HHV
<b>Capacity</b>			
Nominal	18,000	24,000	30,000
Cooling (Btu/h) (Min.~Rated~ Max.) <sup>1</sup>	8,400 ~ 18,000 ~ 19,980	8,400 ~ 24,000 ~ 30,000	8,400 ~ 28,400 ~ 34,080
Cooling Power Input (kW) (Min.~Rated~ Max.)	0.88 ~ 1.33 ~ 1.87	0.94 ~ 1.78 ~ 2.49	0.95 ~ 2.27 ~ 3.18
Cooling Running Current (A) (Min.~Rated~ Max.)	4.0 ~ 6.0 ~ 8.5	4.3 ~ 8.1 ~ 11.3	4.3 ~ 10.3 ~ 14.5
Heating (Btu/h) (Min.~Rated~ Max.) <sup>1</sup>	10,248~22,000~24,000	10,248~26,000~31,200	10,248~28,600~34,320
Heating Power Input (kW) (Min.~Rated~ Max.)	1.25 ~ 2.22 ~ 3.11	1.26 ~ 2.12 ~ 2.96	1.30 ~ 2.33 ~ 3.26
Heating Running Current (A) (Min.~Rated~ Max.)	5.7 ~ 10.1 ~ 14.1	5.7 ~ 9.6 ~ 13.5	5.9 ~ 10.6 ~ 14.8
<b>Operating Range</b>			
Cooling (°F DB) <sup>2</sup>	14 to +118		
Heating (°F WB)	-13 to +64		
<b>Compressor</b>			
Inverter Quantity	Twin Rotary x 1		
Oil / Type	FVC68D		
<b>Fan (Side Discharge)</b>			
Type	Propeller		
Motor Output (W) x Qty.	124.2 x 1		
Motor / Drive	Brushless Digitally Controlled / Direct		
Maximum Air Flow Rate (ft. <sup>3</sup> / min.)	2,295		
<b>Unit Data</b>			
Refrigerant Type	R410A		
Refrigerant Control / Location	Electronic Expansion Valve / Outdoor Unit		
Min. Number Indoor Units/System <sup>3</sup>	2	2	2
Max. Number Indoor Units/System <sup>3</sup>	2	3	4
Maximum Allowable Total Indoor Unit Connected Capacity (Btu/h)	24,000	33,000	40,000
Sound Pressure ±3 dB(A) (Cooling / Heating) dB(A) <sup>4</sup>	50 / 54	52 / 55	52 / 55
Dimensions (W x H x D [inch])	37-13/32 x 32-27/32 x 13		
Net Unit Weight (lbs.)	147.7	152.1	152.1
Power Supply (V, Phase, Hz)	208 / 230V, 1, 60		
Communication / Connection (Power) Cable (No. x AWG) <sup>5,6</sup>	4C x 14		
<b>Heat Exchanger</b>			
Material and Fin Coating	Copper Tube/Aluminum Fin and GoldFin™ / Hydrophilic		
Rows/Columns / Fins per inch x Qty.	(3 x 38 x 16) x 1		
<b>Piping</b>			
Liquid Line Connection (in., O.D.) x Qty.	Ø1/4 x 2	Ø1/4 x 3	Ø1/4 x 4
Vapor Line Connection (in., O.D.) x Qty.	Ø3/8 x 2	Ø3/8 x 3	Ø3/8 x 4
Factory Charge oz. of R410A	98.8	112.8	
Additional Charging Volume (oz. / ft.)	0.22		
<b>Piping Lengths</b>			
Maximum Total Piping (ft.) <sup>7</sup>	164	246.1	
Maximum Outdoor Unit to Indoor Unit Piping (ft.)	82.0		
Piping Length (No Additional Refrigerant [ft.])	49.2	73.8	98.4
Maximum Elevation between Outdoor Unit and Indoor Unit (ft.)	49.2		
Maximum Elevation between Indoor Unit and Indoor Unit (ft.)	24.6		

<sup>1</sup>Capacity is rated with non-ducted IDUs, 0 ft. above sea level, with a 0 ft. level difference between ODU and IDUs, and the following refrigerant pipe lengths:

LMU180HHV: 16.4 ft. x 2 = 32.8 ft.

LMU240HHV: 16.4 ft. x 3 = 49.2 ft.

LMU300HHV: 16.4 ft. x 4 = 65.6 ft.

All capacities are net with a combination ratio between 95 – 105%.

Rated cooling capacity obtained with air entering the indoor unit at 80°F dry bulb (DB) and 67°F wet bulb (WB) and outdoor ambient conditions of 95°F dry bulb (DB) and 75°F wet bulb (WB).

Rated heating capacity obtained with air entering the indoor unit at 70°F dry bulb (DB) and 60°F wet bulb (WB) and outdoor ambient conditions of 47°F dry bulb (DB) and 43°F wet bulb (WB).

<sup>2</sup>Cooling operation range with Low Ambient Wind Baffle Kit (sold separately) is -4°F to +118°F.

<sup>3</sup>At least two indoor units must be connected. For allocated capacity information, see the

combination tables in the "Multi F / Multi F MAX with LGRED Combination Data Manual" on [www.lghvac.com](http://www.lghvac.com). For performance data, see "Multi F / Multi F MAX with LGRED Performance Data Manual" on [www.lghvac.com](http://www.lghvac.com).

<sup>4</sup>Sound pressure levels are tested in an anechoic chamber under ISO Standard 3745 and are the same in both cooling and heating mode. These values can increase due to ambient conditions during operation.

<sup>5</sup>Power wiring to the outdoor unit is field supplied, solid or stranded, and must comply with all the applicable local and national codes. For detailed information, please refer to electrical characteristics on page 10.

<sup>6</sup>Communication / connection (power) cable from the outdoor units to the indoor units must be a minimum of 14 AWG, 4-conductor stranded, shielded or unshielded (if shielded, it must be grounded to the chassis of the outdoor unit only), and must comply with applicable local and national codes. For detailed electrical information, please refer to electric characteristics on page 10.

<sup>7</sup>Piping lengths are equivalent.

# GENERAL DATA

## Multi F with LGRED Outdoor Unit Electrical Data



Table 2: Multi F with LGRED Electrical Data.

Nominal Tons	Unit Model No.	Hertz	Voltage	Voltage Range (Min. to Max.)	MCA	MOP	RFA	Compressor Quantity	Compressor Motor RLA	Outdoor Unit Fan Motor		Indoor Unit Fan Motor
										kW	FLA	FLA
1.5	LMU180HHV	60	208 - 230	187 - 253	18.6	30	25	1	13	0.12	0.73	1.6
2	LMU240HHV				19	30	25	1	13	0.12	0.73	2.0
2.5	LMU300HHV				19.4	30	25	1	13	0.12	0.73	2.4

Voltage tolerance is  $\pm 10\%$ .

Maximum allowable voltage unbalance is 2%.

MCA = Minimum Circuit Ampacity.

Maximum Overcurrent Protection (MOP) is calculated as follows: (Largest motor FLA x 2.25) + (Sum of other motor FLA) rounded down to the nearest standard fuse size.

RFA = Recommended Fuse Amps.

RLA = Rated Load Amps.

FLA = Full Load Amps.

Indoor Fan Motor (FLA) is based on the max. combination of IDUs.

The maximum combination for each outdoor unit is:

- 18,000 ODU (LMU180HHV): 12,000 IDU x 2

- 24,000 ODU (LMU240HHV): 12,000 IDU x 2 + 9,000 IDU x 1

- 30,000 ODU (LMU300HHV): 12,000 IDU x 3

Figure 1: LMU180HHV, LMU240HHV, and LMU300HHV External Dimensions.

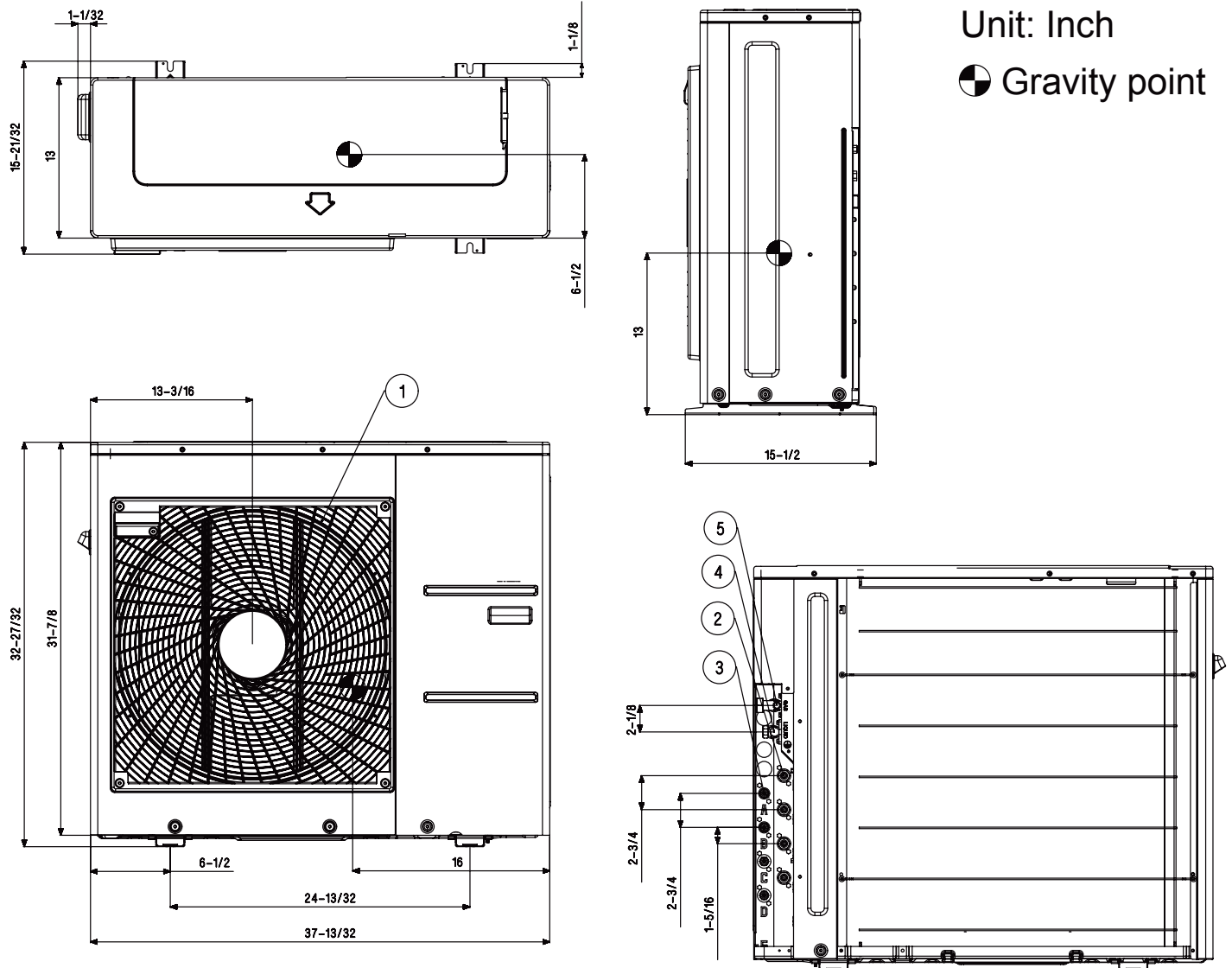

No.	Part Name
1	Air discharge grille
2	Gas pipe connection
3	Liquid pipe connection
4	Main service valve (Liquid)
5	Main service valve (Gas)

# GENERAL DATA

MULTI F WITH LGRED<sup>®</sup>  
MULTI F MAX

## Multi F MAX with LGRED Outdoor Unit Specifications

Table 3: Multi F MAX with LGRED Outdoor Unit Specifications.

Model Number	LMU361HHV	LMU421HHV	LMU480HHV
<b>Capacity</b>			
Cooling (Btu/h) (Min.~Rated~ Max.) <sup>1</sup>	10,800~36,000~47,000	10,800~42,000~53,000	10,800~48,000~58,000
Cooling Power Input (kW) (Min.~Rated~ Max.)	0.64~2.48~4.07	0.64~3.04~4.71	0.64~3.66~5.17
Cooling Running Current (A) (Min.~Rated~ Max.)	2.9~11.2~18.5	2.9~13.8~21.3	2.9~16.6~23.4
Heating (Btu/h) (Min.~Rated~ Max.) <sup>1</sup>	12,420~45,000~50,000	12,420~48,000~54,500	12,420~52,500~59,000
Heating Power Input (kW) (Min.~Rated~ Max.)	0.71~3.30~4.31	0.71~3.70~4.70	0.71~4.25~5.09
Heating Running Current (A) (Min.~Rated~ Max.)	3.2~14.9~19.5	3.2~16.8~21.3	3.2~20.0~23.0
<b>Operating Range</b>			
Cooling (°F DB) <sup>2</sup>	14 to 118		
Heating (°F WB)	-13 to +64		
<b>Compressor</b>			
Inverter Quantity	R1 Scroll x 1		
Oil / Type	FVC68D		
<b>Fan (Side Discharge)</b>			
Type	Propeller		
Motor Output (W) x Qty.	124.2 x 2		
Motor / Drive	Brushless Digitally Controlled / Direct		
Maximum Air Flow Rate (CFM)	2,119 x 2		
<b>Unit Data</b>			
Refrigerant Type	R410A		
Refrigerant Control / Location	Electronic Expansion Valve / Outdoor Unit		
Minimum ~ Maximum Number Indoor Units / System <sup>3</sup>	2~5	2~6	2~8
Max. Number of Branch Distribution Units	2		
Min. ~ Max. Allowable Total Indoor Unit Connected Capacity (Btu/h)	18,000 ~ 48,000	18,000 ~ 56,000	18,000 ~ 65,000
Sound Pressure ±3 dB(A) (Cooling / Heating) <sup>4</sup>	53 / 55	54 / 56	
Dimensions (W x H x D [inch])	37-13/32 x 54-11/32 x 13		
Net / Shipping Unit Weight (lbs.)	218 / 243		
Power Supply (V, Phase, Hz)	208 / 230V, 1, 60		
Comm./Conn. (Power) Cable from ODU & BDU/BDU & IDU (No. X AWG) <sup>5,6</sup>	4C x 14 / 4C x 14		
<b>Heat Exchanger</b>			
Material and Fin Coating	Copper Tube / Aluminum Fin and GoldFin™ / Hydrophilic		
Rows/Columns / Fins per inch x Qty.	(2 x 32 x 14) x 2, (1 x 32 x 14) x 2		
<b>Piping</b>			
Liquid Line Connection (in., O.D.) x Qty.	Ø3/8 x 1		
Vapor Line Connection (in., O.D.) x Qty.	Ø3/4 x 1		
Factory Charge oz. of R410A	183.4		
Additional Charging Volume (oz. / ft.)	Main Pipe	0.54	
	Branch Pipe	0.22	
<b>Piping Lengths</b>			
Maximum Total Piping (ft.) <sup>7</sup>	475.7		
Maximum Piping Length (No Additional Refrigerant [ft.])	49.2 ft. of Main Piping + 131.2 ft. of Branch Piping		
Maximum Main Pipe Length (ODU to BDU [ft.])	180.4		
Total Branch Piping (BDU to all IDU [ft.])	295.3		
Maximum Branch Pipe Length (Length between each BDU & IDU [ft.])	49.2		
Maximum Outdoor Unit to IDU Pipe Length (ft.)	229.6		
Maximum Elevation between ODU and IDU (ft.)	98.4		
Maximum Elevation between Indoor Unit and Indoor Unit (ft.)	49.2		
Maximum Elevation between BDU and IDU (ft.)	32.8		
Maximum Elevation between BDU and BDU (ft.)	49.2		

<sup>1</sup>Capacity is rated with non-ducted IDUs, 0 ft. above sea level, with a 0 ft. level difference between ODU and IDUs, and the following refrigerant pipe lengths:

LMU361HHV: 16.4 ft. Main + (16.4 ft. Branch x 5) = 98.4 ft.

LMU421HHV: 16.4 ft. Main + (16.4 ft. Branch x 6) = 114.8 ft.

LMU480HHV: 16.4 ft. Main + (16.4 ft. Branch x 8) = 147.6 ft.

All capacities are net with a combination ratio between 95 – 105%.

Rated cooling capacity obtained with air entering the indoor unit at 80°F dry bulb (DB) and 67°F wet bulb (WB) and outdoor ambient conditions of 95°F dry bulb (DB) and 75°F wet bulb (WB).

Rated heating capacity obtained with air entering the indoor unit at 70°F dry bulb (DB) and 60°F wet bulb (WB) and outdoor ambient conditions of 47°F dry bulb (DB) and 43°F wet bulb (WB).

<sup>2</sup>Cooling operation range with Low Ambient Wind Baffle Kit (sold separately) is -4°F to +118°F.

<sup>3</sup>At least one Branch Distribution Unit is required for system operation; a maximum of two can be installed per outdoor unit with use of Y-branch accessory (PMBL5620). At least two indoor units must be connected. For allocated capacity information, see the combination tables in the "Multi F / Multi F MAX

with LGRED Combination Data Manual" on www.lghvac.com. For performance data, see "Multi F / Multi F MAX with LGRED Performance Data Manual" on www.lghvac.com.

<sup>4</sup>Sound pressure levels are tested in an anechoic chamber under ISO Standard 3745. These values can increase due to ambient conditions during operation.

<sup>5</sup>Power wiring to the outdoor unit is field supplied, solid or stranded, and must comply with the applicable local and national codes. For detailed information, please refer to electrical characteristics on page 13.

<sup>6</sup>Communications / connection (power) cable must be a minimum of 14 AWG, 4-conductor from the outdoor unit to the BD unit, and 14 AWG, 4-conductor from the BD unit to the indoor unit, stranded, shielded or unshielded (if shielded, it must be grounded to the chassis of the outdoor unit only), and must comply with applicable local and national codes. For detailed electrical information, please refer to electric characteristics on page 13.

<sup>7</sup>Piping lengths are equivalent.

MULTI F / MULTI F MAX with LGRED Outdoor Unit Installation Manual

Table 4: Multi F MAX with LGRED Electrical Data.

Nominal Tons	Unit Model No.	Phase	Hertz	Voltage	Voltage Range (Min. to Max.)	MCA	MOP	Compressor Quantity	Compressor Motor RLA	Outdoor Unit Fan Motor(s)		Indoor Unit Fan Motor
										kW x Qty.	FLA x Qty.	FLA
3.0	LMU361HHV	1	60	208 -230	187 - 253	32.7	40	1	22.0	0.12 x 2	1.60 x 2	3.6
3.5	LMU421HHV					32.7	40	1	22.0	0.12 x 2	1.60 x 2	4.2
4.0	LMU480HHV					32.7	40	1	22.0	0.12 x 2	1.60 x 2	4.9

Voltage tolerance is ±10%.

Maximum allowable voltage unbalance is 2%.

MCA = Minimum Circuit Ampacity.

Maximum Overcurrent Protection (MOP) is calculated as follows: (Largest motor FLA x 2.25) + (Sum of other motor FLA) rounded down to the nearest standard fuse size.

RLA = Rated Load Amps.

FLA = Full Load Amps.

Indoor Fan Motor (FLA) is based on the max. combination of IDUs.

# GENERAL DATA

## Multi F with LGRED Outdoor Unit Dimensions

MULTI F WITH LGRED<sup>®</sup>  
MULTI F MAX

Figure 2: LMU361HHV, LMU421HHV, and LMU480HHV External Dimensions.

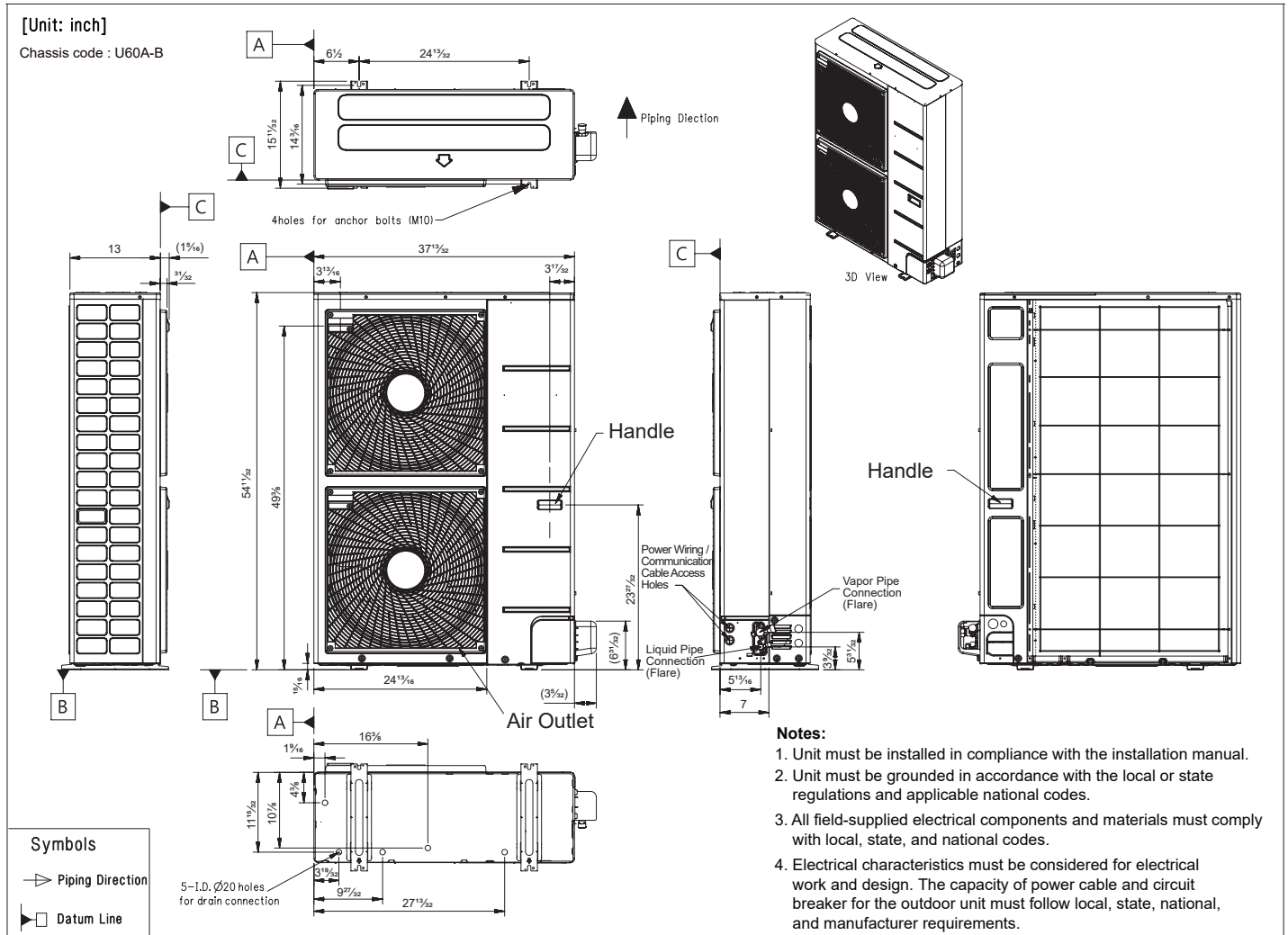

MULTI F / MULTI F MAX with LGRED Outdoor Unit Installation Manual



Table 5: Branch Distribution Unit General Data.

Model Number	PMBD3620	PMBD3630	PMBD3640	PMBD3641
No. of Connectible Indoor Units <sup>1</sup>	1-2	1-3	1-4	1-4
Max. Nominal Capacity / Port (Btu/h) <sup>2</sup>	24,000	24,000	24,000	Ports A, B, C: 24,000; Port D: 36,000
Connected Indoor Unit Capacity (Btu/h)	7,000 ~ 24,000	7,000 ~ 24,000	7,000 ~ 24,000	Ports A, B, C: 7,000 ~ 24,000; Port D: 24,000 or 36,000
Max. Nominal Capacity / Branch Distribution Unit (Btu/h)	48,000	72,000	73,000	73,000
Operation Temperature Range (°F DB)	0 ~ 150	0 ~ 150	0 ~ 150	0 ~ 150
Maximum Humidity	80%	80%	80%	80%
<b>Unit Data</b>				
Refrigerant Type	R410A	R410A	R410A	R410A
Power Supply V, Ø, Hz	208-230, 1, 60	208-230, 1, 60	208-230, 1, 60	208-230, 1, 60
Power Input (W)	16	24	32	32
Rated Amps (A)	0.08	0.12	0.16	0.16
Dimensions W x H x D (in.)	17-3/32 x 6-13/32 x 10-23/32	17-3/32 x 6-13/32 x 10-23/32	17-3/32 x 6-13/32 x 10-23/32	17-3/32 x 6-13/32 x 10-23/32
Net Unit Weight (lbs.)	13	14.3	15.7	15.7
Shipping Weight (lbs.)	15	17	18	18
<b>Communication / Connection (Power) Cables<sup>3</sup></b>				
From Outdoor Unit to Branch Distribution Unit (Qty. x AWG) <sup>3</sup>	4C x 14	4C x 14	4C x 14	4C x 14
From Branch Distribution Unit to Indoor Unit (Qty. x AWG) <sup>3</sup>	4C x 14	4C x 14	4C x 14	4C x 14
<b>Piping Connections</b>				
Outdoor Unit to BDU	Liquid (in., OD)	Ø3/8	Ø3/8	Ø3/8
	Vapor (in., OD)	Ø3/4	Ø3/4	Ø3/4
BDU to Indoor Units	Liquid (in., OD) x Qty.	Ø1/4 x 2	Ø1/4 x 3	Ø1/4 x 4
	Vapor (in., OD) x Qty.	Ø3/8 x 2	Ø3/8 x 3	Ø3/8 x 4
<b>Piping Lengths</b>				
Maximum Total System Piping (ft.) <sup>4</sup>	475.7	475.7	475.7	475.7
Maximum Main Pipe Length (Outdoor Unit to Branch Distribution Units [ft.])	180.4	180.4	180.4	180.4
Total Branch Piping (Branch Distribution Units to Indoor Units [ft.])	295.3	295.3	295.3	295.3
Maximum Branch Pipe Length Between Branch Distribution Unit and Each Indoor Unit [ft.]	49.2	49.2	49.2	49.2
Maximum Outdoor Unit to Indoor Unit Pipe Length (ft.)	229.6	229.6	229.6	229.6
Piping Length (No Additional Refrigerant [ft.]; approx. 49.2 ft. of Main Piping + 131.2 ft. of Branch Piping)	180.4	180.4	180.4	180.4
Maximum Elevation between Branch Distribution Unit and Indoor Unit (ft.)	32.8	32.8	32.8	32.8
Maximum Elevation between Branch Distribution Unit and Branch Distribution Unit (ft.)	49.2	49.2	49.2	49.2

<sup>1</sup>At least one branch distribution Unit is required for system operation; a maximum of two can be installed per outdoor unit with use of Y-branch accessory (PMBL5620) To connect only one (1) indoor unit to a branch distribution unit, the system must include another branch distribution unit with at least one (1) connected indoor unit.

<sup>2</sup>Branch distribution unit can accommodate from one (1) indoor unit up to four (4) indoor units depending on the ports available on the branch distribution unit.

<sup>3</sup>All communication / power (connection) cable must be a minimum of 14 AWG, 4-conductor from the outdoor unit to the branch distribution unit (Multi F MAX with LGRED systems only), and 14 AWG, 4-conductor from the branch distribution unit to the indoor unit, stranded, shielded or unshielded (if shielded, it must be grounded to the chassis of the outdoor unit only), and must comply with applicable local and national codes.

<sup>4</sup>Piping lengths are equivalent.

# GENERAL DATA

## Branch Distribution Unit Dimensions

MULTI F WITH LGRED<sup>®</sup>  
MULTI F MAX

Figure 3: PMBD3620, PMBD3630, PMBD3640, and PMBD3641 External Dimensions.

A-C (and PMBD3640 D) Connections:

Liquid Pipe  $\varnothing 1/4$   
Gas Pipe  $\varnothing 3/8$

PMBD3641 D Connections:

Liquid Pipe  $\varnothing 1/4$   
Gas Pipe  $\varnothing 1/2$

Unit: Inch

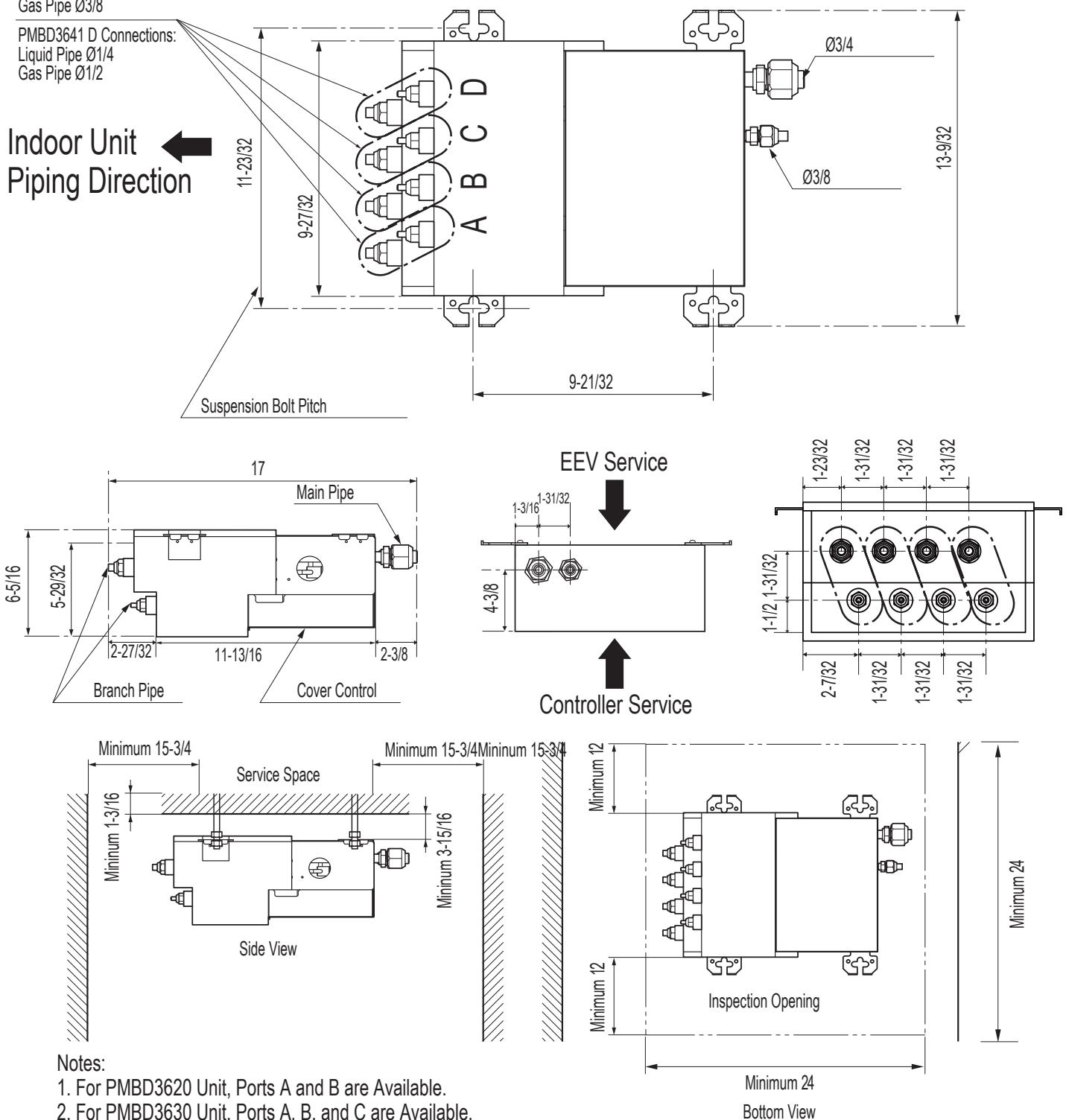

## Transporting / Lifting the Outdoor Unit



- At the time of delivery, the package must be checked for any damage (exterior and interior). Report any damage to the carrier claims agent immediately.
- When lifting the unit, use lifting straps and place properly around the unit.
- Always lift the unit using properly sized lifting straps rated to carry the unit weight.
- Ensure the straps are long enough to maintain a maximum of a 40° angle.

Table 6: Multi F / Multi F MAX with LGRED Shipping and Net Weights.

Capacity (ton)	Shipping Weight (lbs.)	Net Weight (lbs.)
1.5	163.1	147.7
2	165.3	152.1
2.5		
3	243	218
3.5		
4		

### WARNING

**Be very careful when transporting the product. There is a risk of the product falling and causing physical injury.**

- Use appropriate moving equipment to transport each frame; ensure the equipment is capable of supporting the weights listed above. If the equipment is not properly secured, it will result in an accident that causes physical injury or death.
- Wear protective gloves when handling equipment. Sharp edges will cause personal injury.
- Dispose the packing materials safely. Packing materials, such as nails and other metal or wooden parts, will cause puncture wounds or other injuries.
- Tear apart and throw away plastic packaging bags so that children will not play with them and risk suffocation and death.
- Use caution when using a forklift to transport an unpackaged unit. The forklift arms must pass through the openings at the bottom.  Do not drop the unit when carrying it with a forklift. There is a risk of the product falling and causing physical injury.
- Consider the unit's center of gravity before lifting. Hoist the unit with the center of gravity centered among the lifting straps. There is a risk of the product falling and causing physical injury.
- Some products include polypropylene bands around the unit for packaging.  Do not use polypropylene bands to lift the unit. There is a risk of the product falling and causing physical injury.
- Lift the outdoor unit from the base at specified locations. Support the outdoor unit at a minimum of four (4) points to avoid slippage from the rigging apparatus. There is a risk of the product falling and causing physical injury.
- If a crane is to suspend the outdoor unit, it is recommended that two (2) ropes at least twenty-three (23) feet in length be used.
- Pass the ropes under the unit. Pass the rope through the two (2) forklift slots each at the front and rear of the outdoor unit.
- To prevent damage to the outdoor unit, always lift the unit with the ropes attached at four (4) points at an angle of  $\leq 40^\circ$ .

### Note:

- Make sure the outdoor unit is in its original packaging to avoid damage during local transport.
- Handle the outdoor unit with care. Keep the outdoor unit upright to avoid damaging inside components.
- When lifting, always include padding to protect the outdoor unit from rope damage.



# PLACEMENT CONSIDERATIONS

## Selecting the Best Location for the Outdoor Unit

MULTI F WITH LGRED°  
MULTI F MAX

### Selecting the Best Location for the Outdoor Unit

#### ⚠ DANGER

-  Do not install the unit in an area where combustible gas will generate, flow, stagnate, or leak. These conditions can cause a fire, resulting in bodily injury or death.
-  Do not install the unit in a location where acidic solution and spray (sulfur) are often used as it can cause bodily injury or death.
-  Do not use the unit in environments where oil, steam, or sulfuric gas are present as it can cause bodily injury or death.

#### ⚠ CAUTION

When deciding on a location to place the outdoor unit, be sure to choose an area where run-off from defrost will not accumulate and freeze on sidewalks or driveways, which will create unsafe conditions. Properly install and insulate any drain hoses to prevent the hose from freezing, cracking, leaking, and causing unsafe conditions from frozen condensate.

#### ⚠ WARNING

Install a fence to prevent vermin from crawling into the unit or unauthorized individuals from accessing it. Vermin and unauthorized individuals will cause a fire, electric shock, physical injury or death. Follow the placement guidelines set forth in "Clearance Requirements".

#### Note:

Install a fence to prevent vermin from crawling into the unit or unauthorized individuals from accessing it. Vermin and unauthorized individuals will damage the unit. Follow the placement guidelines set forth in "Clearance Requirements".

Select a location for installing the outdoor unit that will meet the following conditions:

- Where there is enough strength to bear the weight of the unit.
- A location that allows for optimum air flow and is easily accessible for inspection, maintenance, and service.
- Where piping between the outdoor unit and indoor unit (and branch distribution unit[s], if Multi F MAX with LGRED) is within allowable limits.
- Include space for drainage to ensure condensate flows properly out of the unit when it is in heating mode.  Avoid placing the outdoor unit in a low-lying area where water could accumulate.
- If the outdoor unit is installed in a highly humid environment (near an ocean, lake, etc.), ensure that the site is well-ventilated and has a lot of natural light (Example: Install on a rooftop).

#### Do Not's

- Where it will be subjected to direct thermal radiation from other heat sources, or an area that would expose the outdoor unit to heat or steam like discharge from boiler stacks, chimneys, steam relief ports, other air conditioning units, kitchen vents, plumbing vents, and other sources of extreme temperatures.
- Where high-frequency electrical noise / electromagnetic waves will affect operation.
- Where operating sound from the unit will disturb inhabitants of surrounding buildings.
- Where the unit will be exposed to direct, strong winds.
- Where the discharge of one outdoor unit will blow into the inlet side of an adjacent unit (when installing multiple outdoor units).

### Outdoor Unit Condensate Drain Piping

Outdoor unit requires condensate drain piping. Condensate drain pipe is constructed with materials approved by local code. See pages 20 to 22 for information in reference to outdoor unit placement.

### Planning for Snow and Ice

To ensure the outdoor unit operates properly, certain measures are required in locations where there is a possibility of heavy snowfall or severe windchill or cold:

1. Prepare for severe winter wind chills and heavy snowfall, even in areas of the country where these are unusual phenomena.
2. Position the outdoor unit so that its airflow fans are not buried by direct, heavy snowfall. If snow piles up and blocks the airflow, the system will malfunction.
3. Remove any snow that has accumulated four (4) inches or more on the top of the outdoor unit.
4. In climates that will experience significant snow buildup, mount the outdoor unit on a raised, field-provided platform or stand. The raised support platform must be high enough to allow the unit to remain above possible snow drifts, and must be higher than the maximum anticipated snowfall for the location.
5. Design the mounting base to prevent snow accumulation on the platform in front or back of the unit frame.
6. Provide a field fabricated snow protection hood to keep snow and ice and/or drifting snow from accumulating on the coil surfaces.
7. To prevent snow and heavy rain from entering the outdoor unit, install the condenser air inlets and outlets facing away from direct winds.
8. Consider tie-down requirements in case of high winds or where required by local codes.

### Planning for Snow and Ice, continued.

#### ⚠ CAUTION

When deciding on a location to place the outdoor unit, be sure to choose an area where run-off from defrost will not accumulate and freeze on sidewalks or driveways, which will create unsafe conditions. Properly install and insulate any drain hoses to prevent the hose from freezing, cracking, leaking, and causing unsafe conditions from frozen condensate.

### Rooftop Installations

If the outdoor unit is installed on a roof structure, be sure to level the unit. Ensure the roof structure and anchoring method are adequate for the unit location. Consult local codes regarding rooftop mounting.

### Oceanside Installation Precautions

- Install the outdoor unit on the side of the building opposite from direct ocean winds.
- Select a location with good drainage.
- Periodically clean dust or salt particles off of the heat exchanger with water.



Avoid installing the outdoor unit where it would be directly exposed to ocean winds.

#### Note:

Additional anti-corrosion treatment will need to be applied to the outdoor unit at oceanside locations.

### Tie-Downs and Lightning Protection

#### Tie-Downs

- The strength of the roof must be checked before installing the outdoor units.
- If the installation site is prone to high winds or earthquakes, when installing on the wall or roof, securely anchor the mounting base using a field-provided tie-down configuration approved by a local professional engineer.
- The overall tie-down configuration must be approved by a local professional engineer. Always refer to local code when using a wind restraint system.

#### Lightning Protection

- To protect the outdoor unit from lightning, it must be placed within the specified lightning safety zone.

Table 7: Safety Zone Specifications.

Building Height (feet)	66	98	148	197
Protection Angle (°)	55	45	35	25

- Power cable and communication cable must be installed five (5) feet away from lightning rod.
- A high-resistance ground system must be included to protect against induced lightning or indirect strike.

#### Note:

If the building does not include lightning protection, the outdoor unit will be damaged from a lightning strike. Inform the customer of this possibility in advance.

#### Note:

Ocean winds will cause corrosion, particularly on the condenser and evaporator fins, which, in turn could cause product malfunction or inefficient performance.

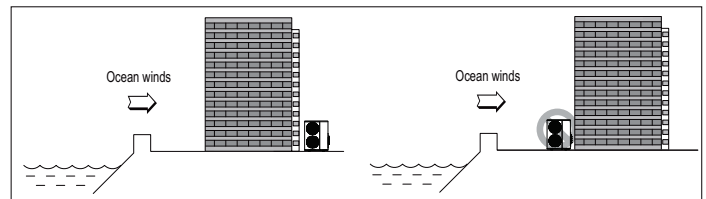

If the outdoor unit must be placed in a location where it would be subjected to direct ocean winds, install a concrete windbreaker strong enough to block any winds. Windbreaker height and width must be more than 150% of the outdoor unit, and be installed at least 27-1/2 inches away from the outdoor unit to allow for airflow.

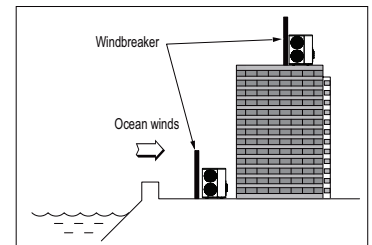
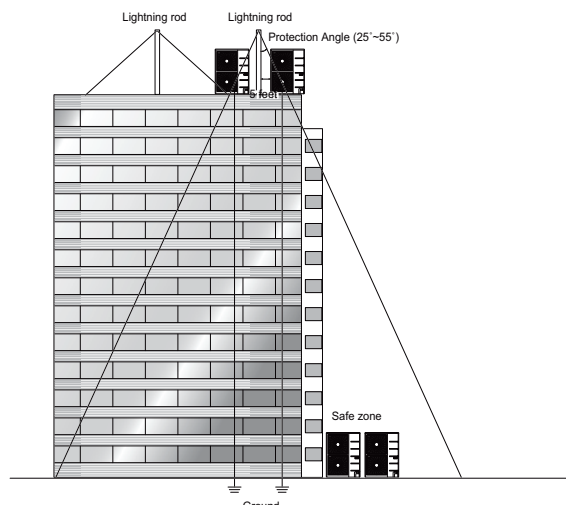

Figure 4: Lightning Protection Diagram.



# PLACEMENT CONSIDERATIONS

Selecting the Best Location for the Outdoor Unit

MULTI F WITH LGRED<sup>®</sup>  
MULTI F MAX

## Minimum Allowable Clearance and Service Access Requirements

Proper clearance for the outdoor unit coil is critical for proper operation. When installing the outdoor unit, consider service, inlet and outlet, and minimum allowable space requirements as illustrated in the diagrams on the following pages.

- Include enough space for airflow and for service access. If installing multiple outdoor units, ⓧ avoid placing the units where the discharge of one unit will blow into the inlet side of an adjacent unit.
- If an awning is built over the unit to prevent direct sunlight or rain exposure, make sure that the discharge air of the outdoor unit isn't restricted.
- ⓧ No obstacles to air circulation around the unit; keep proper distances from ceilings, fences, floor, walls, etc. (Install a fence to prevent pests from damaging the unit or unauthorized individuals from accessing it.)

### Multi F with LGRED Outdoor Unit (18,000, 24,000, 30,000 Btu/h Capacities) Service Access and Allowable Clearances

Specific clearance requirements in the diagram below are for (18,000, 24,000, 30,000 Btu/h capacities). Figure 5 shows the overall minimum clearances that must be observed for safe operation and adequate airflow around the outdoor unit.

When placing the outdoor unit under an overhang, awning, sunroof or other "roof-like structure", observe the clearance requirements (as shown in Cases 1 and 2) for height in relation to the unit. To have successful service access to the outdoor unit, see Figure 5 for minimum spacing. When installing multiple outdoor units, see Cases 4 and 5 for correct spacing requirements.

#### Note:

If the outdoor unit is installed between standard and minimum clearances, capacity decreases approximately 10%.

Figure 5: Multi F with LGRED 18,000, 24,000, 30,000 Btu/h Capacity Outdoor Unit Service Access and Allowable Clearances Diagram.

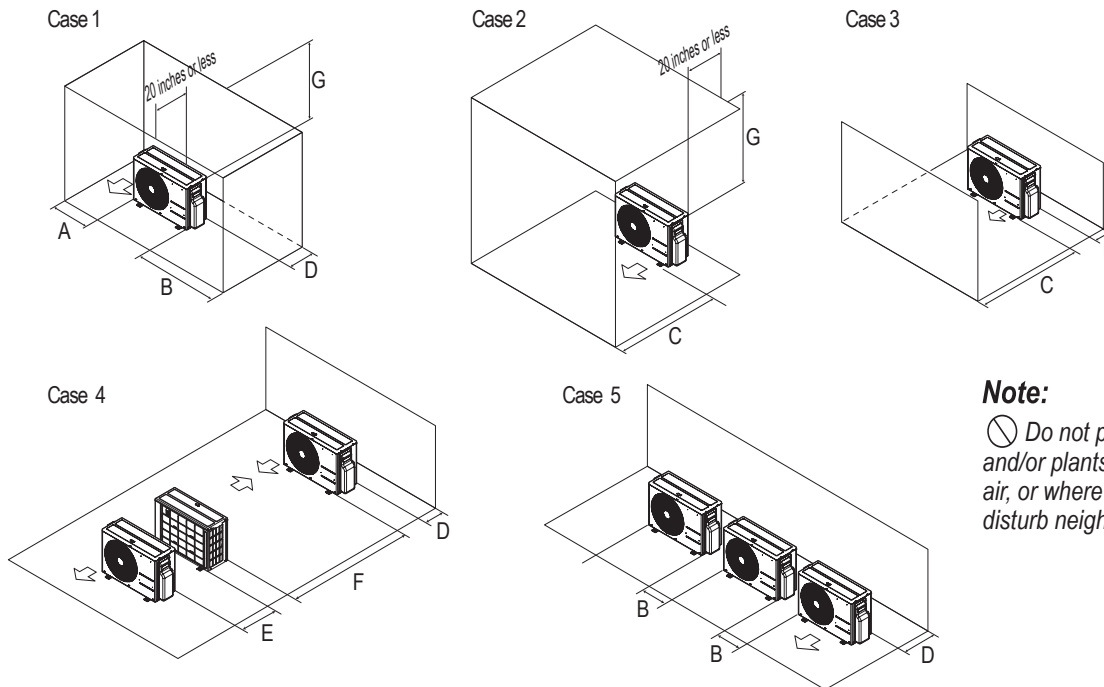

#### Note:

ⓧ Do not place the unit where animals and/or plants will be in the path of the warm air, or where the warm air and/or noise will disturb neighbors.

Table 8: Multi F with LGRED 18,000, 24,000, and 30,000 Outdoor Unit Service Access and Allowable Clearances Diagram Legend.

Unit: Inch		A	B	C	D	E	F	G
Case 1	Standard	12	24	-	12	-	-	-
	Minimum	4	10	-	4	-	-	40
Case 2	Standard	-	-	20	-	-	-	-
	Minimum	-	-	14	-	-	-	40
Case 3	Standard	-	-	20	12	-	-	-
	Minimum	-	-	14	4	-	-	-
Case 4	Standard	-	-	-	12	24	-	-
	Minimum	-	-	-	4	8	79	-
Case 5	Standard	-	24	-	12	-	-	-
	Minimum	-	10	-	4	-	-	-

### Multi F MAX with LGRED Outdoor Unit (36,000, 42,000, 48,000 Btu/h Capacity) Service Access and Allowable Clearances

When installing the outdoor unit, consider service, inlet, and outlet, and minimum allowable space requirements as illustrated in the following diagrams.

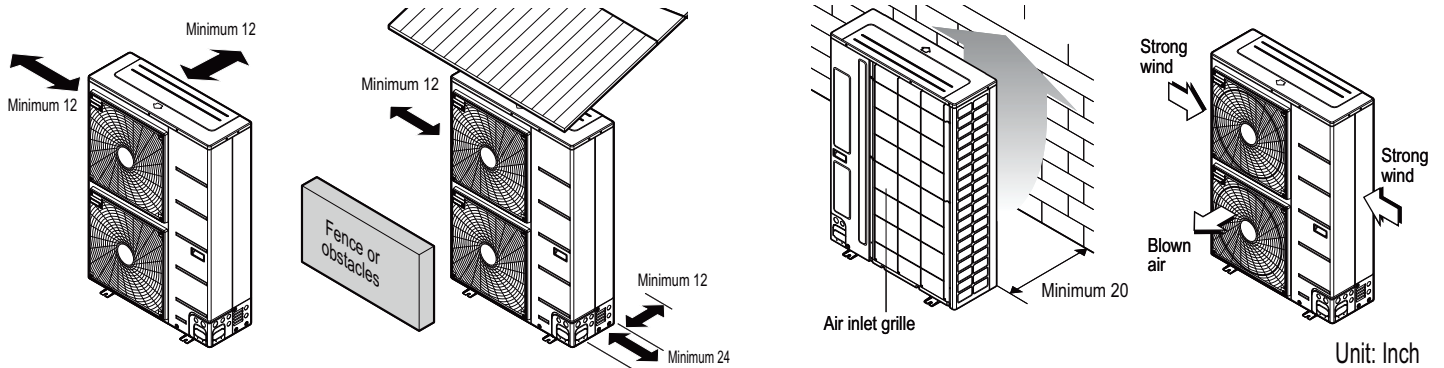

Ensure that the space at the back of the outdoor unit is a minimum of 12 inches, and include a minimum of 24 inches at the right side of the unit for service.

If the outdoor unit discharge side faces a wall, include a minimum of 20 inches between the outdoor unit and the wall. Install the outdoor unit so that the discharge port is set at a right angle to the wind direction.

Unit: Inch

### Clearance Requirements when Different Obstacles are Present (Unit: Inch).

Obstacle on the suction side only.

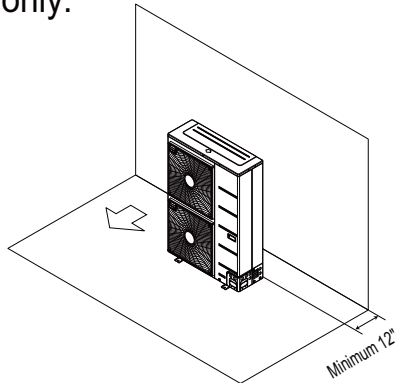

Obstacles on the suction side and on both left and right sides.

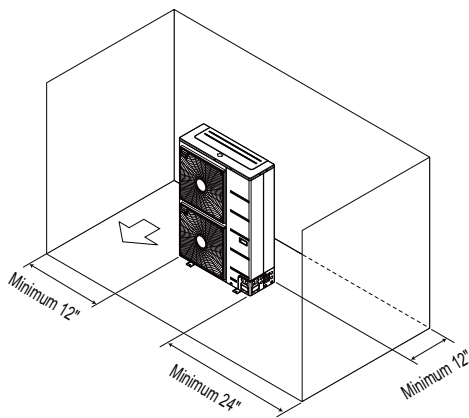

Obstacles above and on the air intake side.

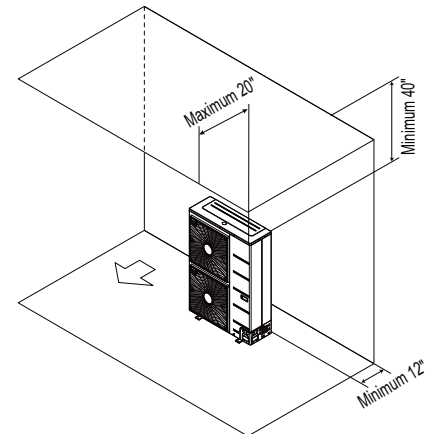

Obstacles above, on the air intake side, and on both left and right sides.

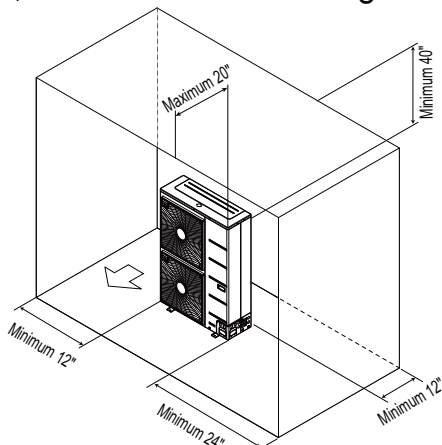

Obstacle just on the air discharge side.

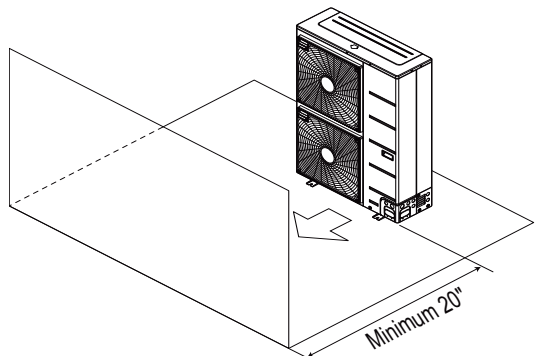

# PLACEMENT CONSIDERATIONS

MULTI F WITH LGRED<sup>®</sup>  
MULTI F MAX

## Selecting the Best Location for the Outdoor Unit

### Clearance Requirements when Different Obstacles are Present, continued. (Unit: Inch)

Obstacles above and on the air discharge side.

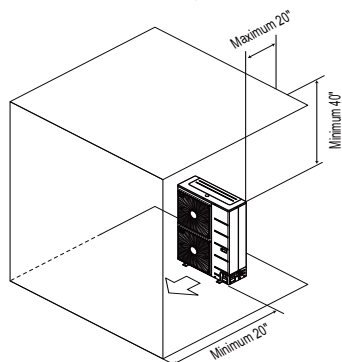

Where there are obstacles on both suction and discharge sides (discharge side obstacle is higher than the outdoor unit).

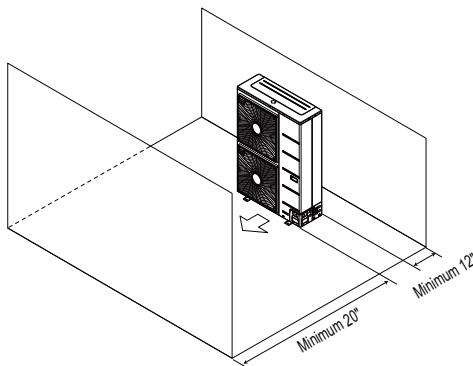

Where there are obstacles on both suction and discharge sides (discharge side obstacle is lower than the outdoor unit).

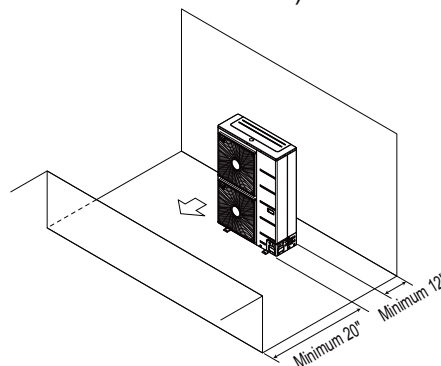

Where there are obstacles above, and on both suction and discharge sides (discharge side obstacle is higher than the outdoor unit).

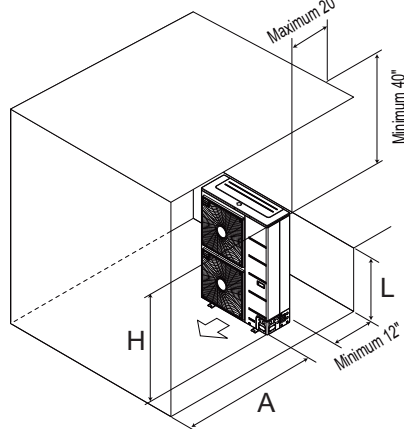

Where there are obstacles above, and on both suction and discharge sides (discharge side obstacle is lower than the outdoor unit).

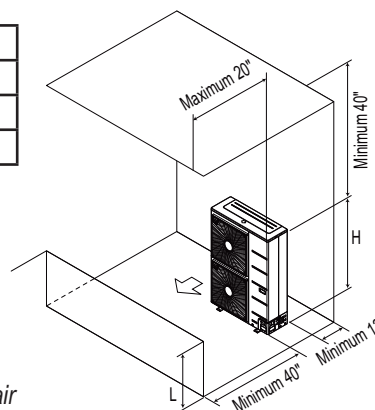

Table 9: Ratio among H, A, and L.

	L	A
$L \leq H$	$0 < L \leq 1/2 H$	30 inches
	$1/2 H < L$	40 inches
$H < L$	Set Stand as: $L \leq H$	

If a stand is necessary, it must be contained (not open frame) to prevent the discharge air from short cycling.

### Note:

"L" must be lower than "H". If a stand is necessary, it must be contained (not open frame) to prevent the discharge air from short cycling.

Series installation.

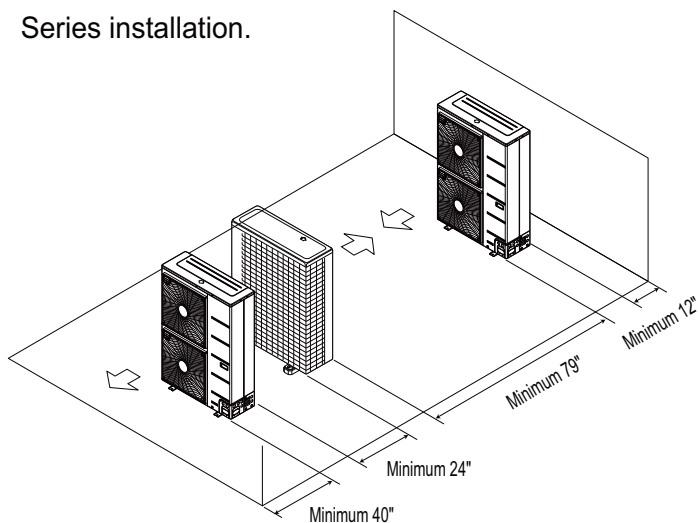

Side-by-side series installation.

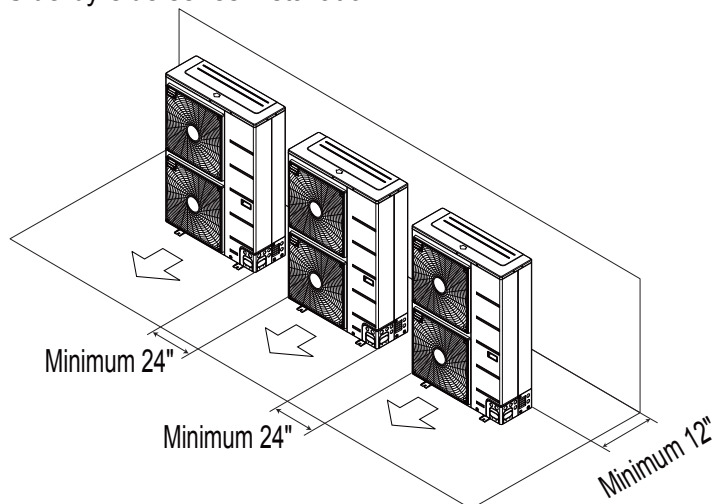

### Installing Outdoor Units Indoors

LG Multi F / Multi F MAX with LGRED outdoor units are engineered to be mounted outdoors and include technology designed to minimize the negative effects of winter weather's freezing rain, sleet, and snow. Some building projects, however, necessitate placing the HVAC outdoor units indoors:

- Lack of ground space.
- Lack of an appropriate outdoor location that meets system design requirements.
- When mounting on the roof is not an option due to a lack of roof space.
- Roof warranty will be voided if mechanical equipment is placed on the membrane.
- On retrofit projects, a former chiller / boiler / air handler equipment room, mechanical area, or penthouse already exists.
- To curtail the potential need for redundant zone heating devices such as wall-fin radiators or duct heaters.
- In extremely cold environments where there is a significant amount of run-time at temperatures well below freezing outside the outdoor unit ambient air temperature range published in this engineering manual.

### Benefits of Installing Outdoor Units Indoors

- Shelters the outdoor unit from direct exposure to prevailing winds that decrease the heating capability of the outdoor unit.
- Protects equipment from freezing precipitation and/or potential ice build-up that could hinder unit operation.
- Maintains coil heat transfer efficiency by reducing the number of and shortening the cycle time for defrost operation.
- Easier maintenance and servicing during inclement weather.
- When mounted in a fully enclosed space, limiting the ambient air temperature will allow the Multi F / Multi F MAX with LGRED system designer to eliminate oversizing.
- The outdoor unit to compensate for loss of capacity at low ambient temperatures.
- Will also curtail the need to provide inefficient redundant zone heating devices such as wall-fin radiators and second-stage ancillary heating devices.

### Design Considerations Include:

- Enclosure types and elements such as louvers (see next page), rain hoods, dampers and controls, heating methods and sizing of heating devices.
- Heating strategies.
- Duct design.
- Condensate handling.

### General Guidelines

- Follow ASHRAE 62.1 design guidelines.
- Depending on the project / application, a roof over the outdoor units in combination with a wind break will be all that is necessary.
- Consider the potential for snow accumulation near louvers / roof openings. Outside air intakes and discharge ducts/louvers must be engineered to clear anticipated snow accumulation levels by at least one (1) foot.
- In situations where operation is anticipated at temperatures of -13°F and lower, ancillary heat must be provided to heat the outdoor unit coils to assure continuous compressor operation and heating.

It will be necessary to use a field-fabricated air guide to prevent discharge air from short-cycling back to the coil inlet.

- Consider the direction of prevailing winds and opening placement. If possible, locate inlet openings upwind of discharge openings and other exhaust outlets.
- When inlet and outlet openings are placed on the same wall, minimum distance between the two openings must be approximately three (3) feet (minimum distance varies significantly with variations in outlet opening face velocity).
- If roof-mounted ventilation openings are used, strategically locate the inlet ventilation opening(s) upwind of the outlet opening(s).
- Discharge and supply ductwork must be designed to avoid weather related long periods of water entrainment and the potential for microbial growth.

# PLACEMENT CONSIDERATIONS

MULTI F WITH LGRED<sup>®</sup>  
MULTI F MAX

## Selecting the Best Location for the Outdoor Unit

Provide a means to drain the condensate generated during heating mode and defrost cycle in addition to rainwater that infiltrates the inlet louver enclosed area.

- Install a field-provided drain pan under the outdoor units and provide a path to a nearby floor drain.
- If the ambient air temperature is expected to drop below 32°F in the enclosure, heat the bottom surface of the pan, drain line, and floor drain so that the condensate does not freeze before reaching the drain.

### ⚠ CAUTION

When deciding on a location to place the outdoor unit, be sure to choose an area where run-off from defrost will not accumulate and freeze on sidewalks or driveways which will create unsafe conditions.

Allow for ventilation intake and exhaust air based on maximum outdoor unit fan capacity.

- Select the size, type and orientation of architectural louvers with adequate “net free area” face velocity to ensure the total external static pressure from the outdoor unit fan does not exceed design limitations (see specification data tables).
- No obstructions must be placed in front of the louver that could hamper the free flow (throw) of air.
- Roof top openings and / or discharge and supply louvers must be equipped with screens to prevent bird and insect infiltration.

### Note:

For louver recommendations, see below and on the next page.

As always, the best solution for each project balances acceptable heating performance (considering local weather conditions), capital costs, life cycle energy consumption, and limitations set forth by local building codes.

## Louver Recommendations for Outdoor Unit Enclosure

1. Outdoor Unit Enclosure: Manual Door Open Type.
2. Louver Angle: No More Than 15° Horizontally.
3. Space Between Louvers: More than 4 inches (Recommend).
4. Louver Shape: Wing or Plane Type.

### Note:

- Open Rate and Inlet must be taken into consideration when designing the louvered outdoor unit enclosure.
- Do not use “S” type louvers.

### Note:

#### If the Louver Open Rate is Too Small

1. Noise can occur because of the increased air velocity passing through the louver blade.
2. Noise can occur from louver blade vibrations.
3. A drop in outdoor unit fan performance (excess static pressure can cause a drop in outdoor unit performance and heat exchanger efficiency).
4. If the louver open rate is too small or there is insufficient air flow exchange, the air conditioner might stop operating.

Figure 6: Louver Recommendations.

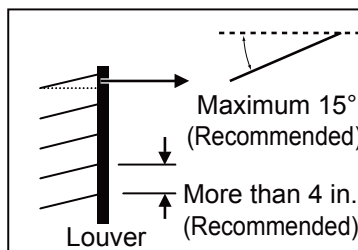
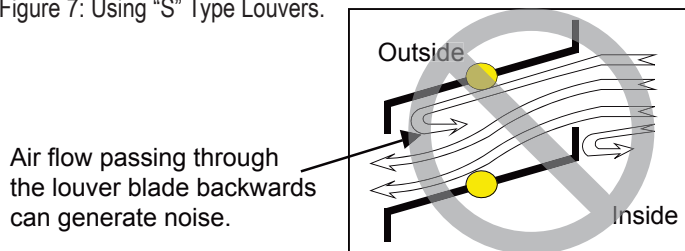
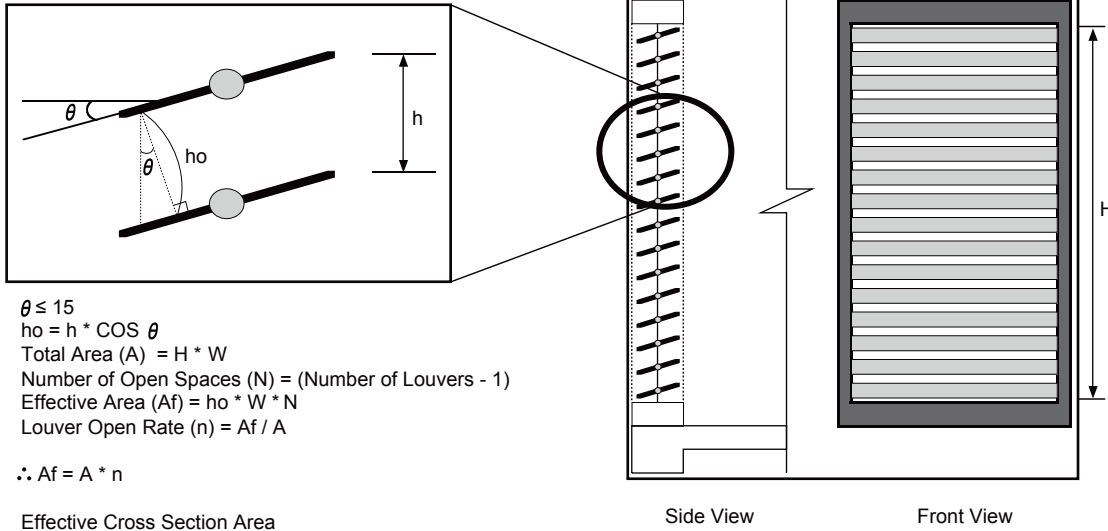

Figure 7: Using “S” Type Louvers.



### Open Rate by Louver Radian

Figure 8: Open Rate by Louver Radian Formula.



### Confirming Air Flow Rate / Total Opening Rate

Figure 9: Example of Installing Outdoor Unit Indoors.

• Example: LMU361HHV

• Discharge Airflow Rate: 4,238 ft.<sup>3</sup>/min.

• Velocity of Outlet Air: 12.9 ft./s

• Velocity of Inlet Air: 7.7 ft./s

• Open Rate = 80% or More

$$\text{Open Rate} = \frac{\text{Effective Face Area (Af)}}{\text{Total Face Area (A)}}$$

• Inlet airflow should match or exceed discharge airflow.

• Separate inlet airflow from discharge airflow to prevent recirculation.

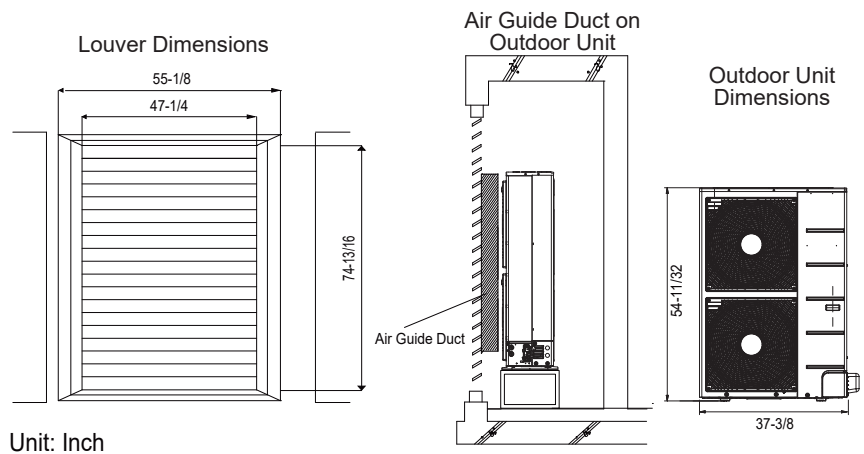

### Formula

• Total Louver Dimension (Excluding Frame) (A) = 3.9 feet x 6.2 feet = 24.2 ft.<sup>2</sup>

• Area Blocked by Outdoor Unit (Discharge) (B) = 3.12 feet x 4.53 feet = 14.13 ft.<sup>2</sup>

• Inlet Louver Dimension (A - B) = 10.1 ft.<sup>2</sup>

• Equivalent Inlet Dimension (Open Rate 80%) = 10.1 ft.<sup>2</sup> x 0.8 = 8.08 ft.<sup>2</sup>

• Equivalent Inlet Air Volume = 8.08 ft.<sup>2</sup> x 7.7 ft./s x 60 sec./min. = 3,734 ft.<sup>3</sup>/min.

• Equivalent Inlet Airflow / Discharge Airflow = 3,734 ft.<sup>3</sup>/min. / 4,238 ft.<sup>3</sup>/min. = 88% (Not Allowed; Suction Airflow Must Equal / Exceed Discharge Airflow)

# PLACEMENT CONSIDERATIONS

MULTI F WITH LGRED<sup>®</sup>  
MULTI F MAX

## Selecting the Best Location for the Indoor Units / Branch Distribution Units

### Selecting the Best Location for the Indoor Units

#### Note:

Select a location for installing the indoor units that will meet the following conditions:

- Within allowable parameters for proper connection to the outdoor unit (and branch distribution unit, if a Multi F MAX with LGRED system).
- So that condensation drainage can be conveniently routed away.
- Include enough space around the indoor unit so that it is accessible for maintenance and service purposes.
- Where electrical noise / electromagnetic waves will not affect indoor unit operation. Maintain proper distances between the indoor units and electric wires, audio and visual appliances, breaker / circuit panels, etc. If the frequency signal of the appliance is unstable, then install the indoor unit a minimum of ten (10) feet away, and run the power and transmission cables through a conduit.
- An area that is level and with enough strength to bear the weight of the indoor unit(s).

#### Do Not's

- Install in an area with obstacles to air circulation around the unit; keep proper distances from ceilings, doorways, floor, walls, etc.
- Install in an area where operation sound will disturb occupants.
- Install in an area that exposes the indoor unit(s) to heat, water, steam, oil splattering or spray.

#### Note:

Indoor units (IDUs) must not be placed in an environment where the IDUs will be exposed to harmful volatile organic compounds (VOCs) or in environments where there is improper air make up or supply or inadequate ventilation. If there are concerns about VOCs in the environment where the IDUs are installed, proper air make up or supply and / or adequate ventilation must be provided. Additionally, in buildings where IDUs will be exposed to VOCs consider a factory-applied epoxy coating to the fan coils for each IDU.

For detailed placement considerations and installation requirements for indoor units, refer to its Indoor Unit Engineering and / or Installation Manuals.

### Selecting the Best Location for the Branch Distribution (BD) Units

#### Note:

Branch distribution (BD) units are used only with Multi F MAX with LGRED systems to distribute the refrigerant from the outdoor unit up to six (6) indoor units.

Select a location indoors that will meet the following conditions:

- Within allowable parameters for proper connection to the Multi F MAX with LGRED outdoor unit and indoor unit(s); refrigerant piping and wire lengths must not exceed amounts specified by LG Electronics, U.S.A., Inc.
- Condensate drain piping is not required.
- Ensure there is enough space in the installation area for service purposes (minimum 24 inches); install the refrigerant piping and electrical wiring system in an easily accessible location.
- Level where there is enough strength to bear the weight of the branch distribution unit.

#### Do Not's

- Install the branch distribution unit in a location where it would be subjected to strong radiation heat from heat sources.
- Install in an installation environment where the branch distribution unit would be exposed to heat, water, steam, oil splattering or spray.
- Install the unit in a location where any sound it generates will disturb occupants in the surrounding rooms.
- Install in a location where there are obstacles to air circulation around the unit; keep proper distances from ceilings, doorways, floor, walls, etc.
- Install in an area where high-frequency electrical noise / electromagnetic waves will affect operation. Maintain proper distances between the branch distribution unit(s) and electric wires, audio and visual appliances, breaker / circuit panels, etc.

Figure 10: Branch Distribution Unit Key Components.

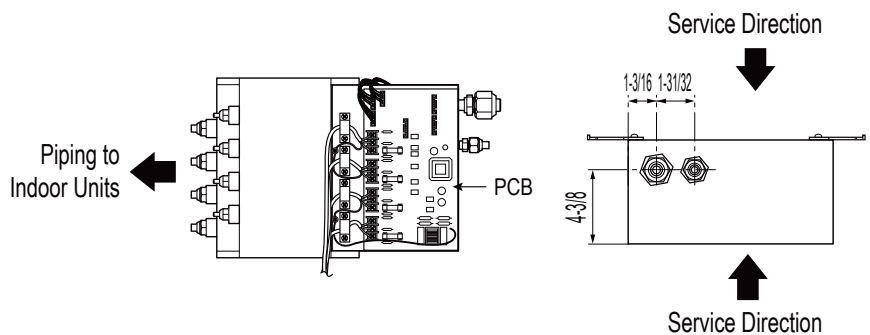

# PLACEMENT CONSIDERATIONS

Selecting the Best Location for the Branch Distribution Units

A-C (and PMBD3640 D) Connections:  
Liquid Pipe Ø1/4  
Gas Pipe Ø3/8

PMBD3641 D Connections:  
Liquid Pipe Ø1/4  
Gas Pipe Ø1/2

Indoor Unit  
Piping Direction ←

Unit: Inch

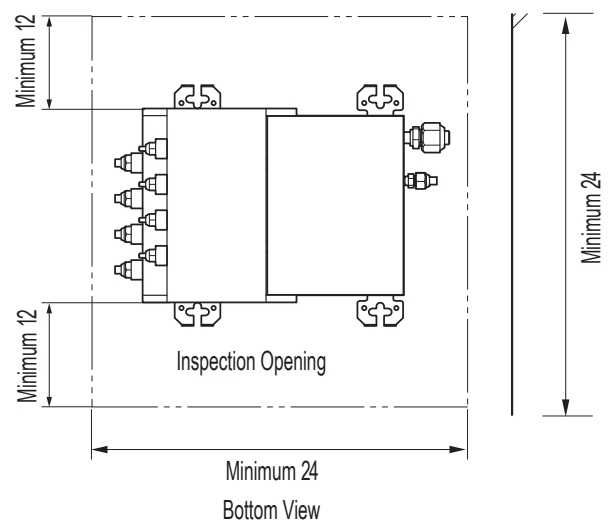
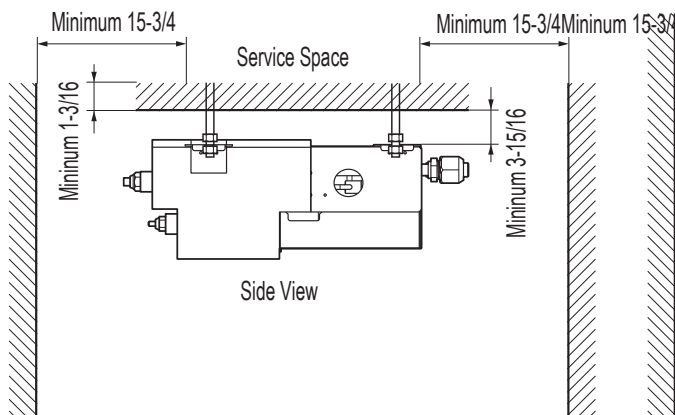
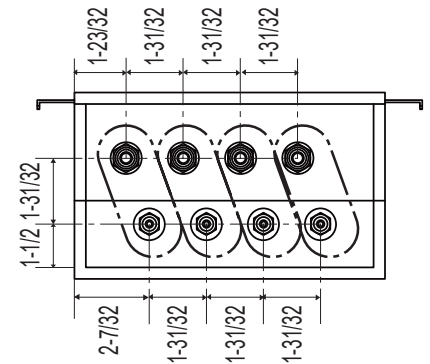
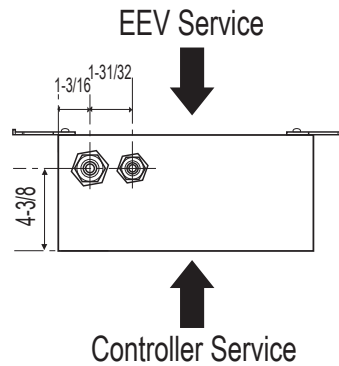
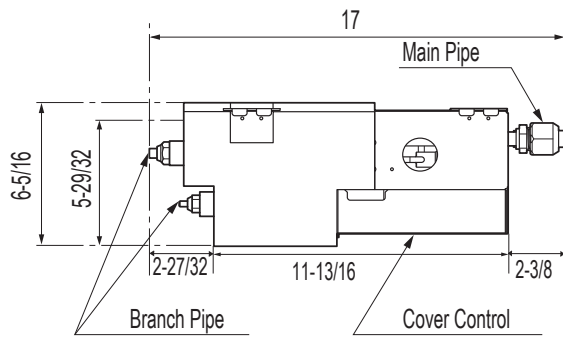
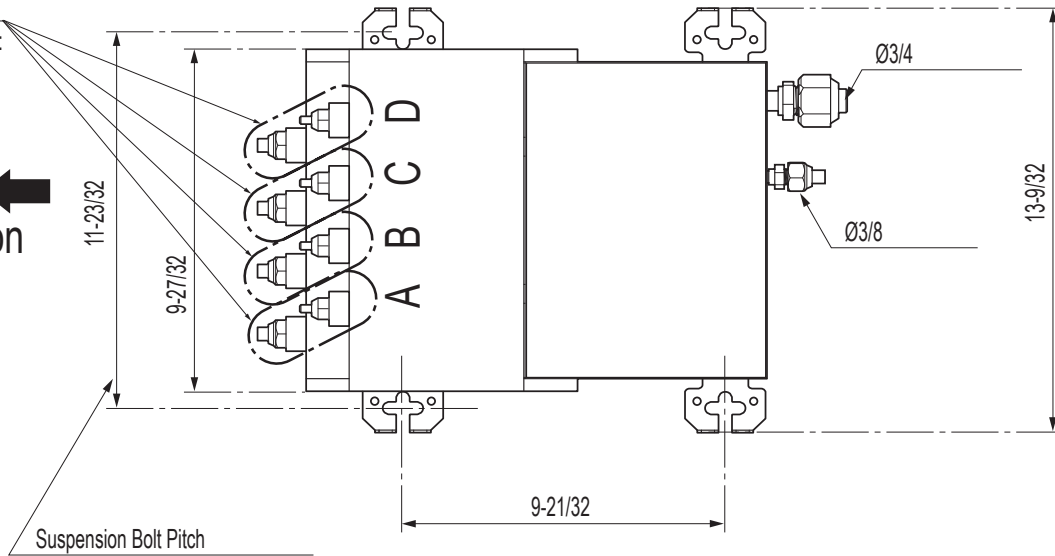

Notes:

1. For PMBD3620 Unit, Ports A and B are Available.
2. For PMBD3630 Unit, Ports A, B, and C are Available.
3. For PMBD3640 and PMBD3641 Units, Ports A, B, C, and D are Available.

Installation

# MOUNTING / ANCHORING THE OUTDOOR UNITS

## Mounting / Anchoring the Outdoor Unit General Specifications

- Tightly anchor the outdoor unit with a bolt and nut to a concrete or rigid platform.
- When installing on a wall (with field-supplied brackets), roof, or rooftop, securely anchor the mounting platform with nails and / or wiring, taking into consideration the possibility of strong winds or earthquakes.
- If installing the outdoor unit on the roof, check the strength of the roof.

### Outdoor Unit Platform Concrete Specifications

- Concrete foundations must be made of one part cement, two parts sand, and four parts gravel.
- The surface of the foundation must be finished with mortar with rounded edges, and weatherproofed.
- See table and figures for height, width, etc., requirements.
- Include an area for drainage around the foundation to ensure condensate thoroughly drains away from the outdoor unit.

Figure 12: Close up of Bolt Attachment.

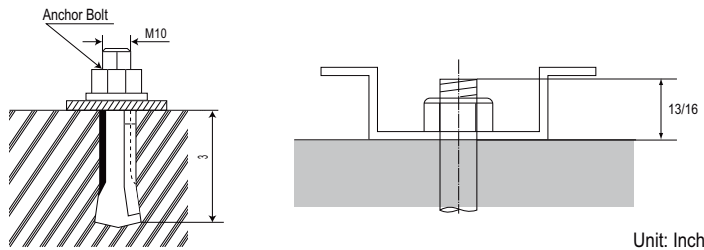
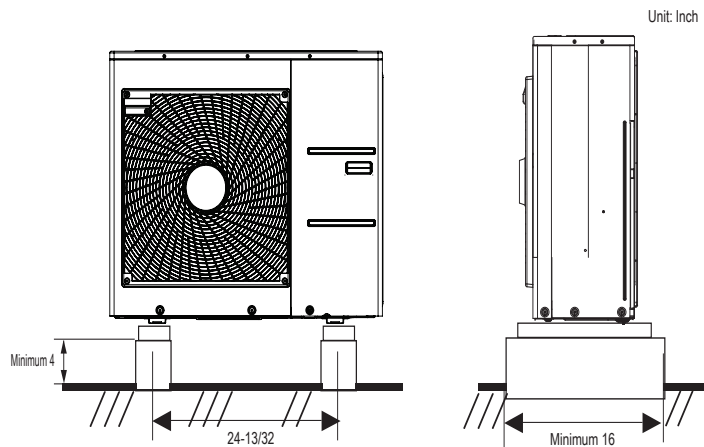

Figure 13: LMU180HHV, LMU240HHV, and LMU300HHV Outdoor Units.



### Bolting the Outdoor Unit to the Platform Procedure

1. Ensure that the concrete platform will not degrade easily, and has enough strength to bear the weight of the unit.
2. Include an H-beam support. Firmly attach the corners, otherwise the support will bend.
3. Use a hexagon nut.
4. If there is a possibility of vibration from the outdoor unit transmitting to the building, add an anti-vibration material to the platform.
5. Include enough space around the concrete foundation for condensate drainage.
6. Seal all wiring and piping access holes with field-supplied sealing material to prevent animals and bugs from entering the unit.

Figure 11: Example of Using an Insert for a Hole in a Reinforced Concrete Beam.

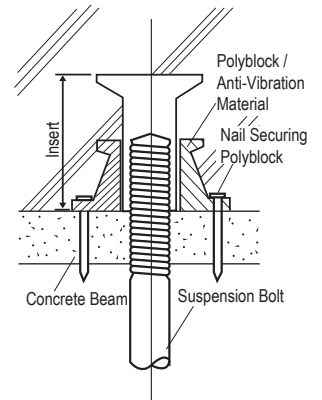

Table 10: Outdoor Unit Foundation Specifications.

Outdoor Unit	Bolt Type	Concrete Height	Bolt Depth
LMU180HHV, LMU240HHV, LMU300HHV	M10-J	Minimum Four (4) Inches	Minimum Three (3) Inches
LMU361HHV, LMU421HHV, LMU480HHV	M10-J	Minimum Eight (8) Inches	Minimum Three (3) Inches

Figure 14: LMU361HHV, LMU421HHV, LMU480HHV Outdoor Units.

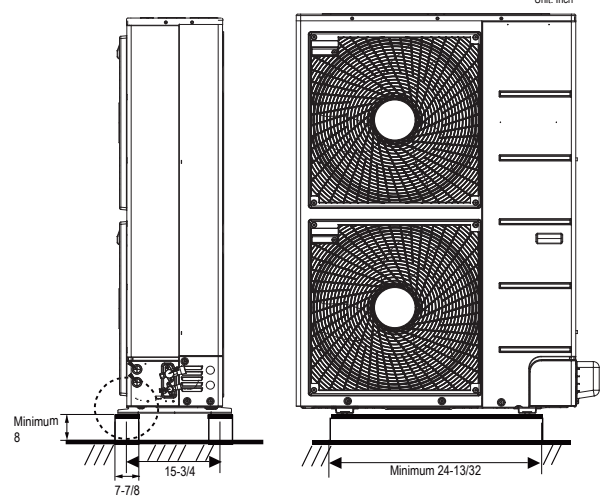
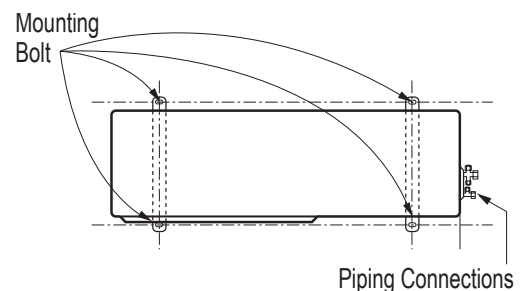

Figure 15: Bolting the Outdoor Unit to the Platform (Piping Location Will Differ Depending on Outdoor Unit Model).



## Branch Distribution Unit Orientation

Multi F MAX with LGRED branch distribution (BD) units can be installed in a multitude of options to fit various building configurations and job or application requirements (suspended from the ceiling or mounted on the wall). The installation location of the PCB within the branch distribution unit can be changed for easier service access, depending on the branch distribution unit installation itself (see the wiring section for information). Branch distribution units include electronic expansion valves that properly seat only if the branch distribution unit is installed in an acceptable orientation. Installations with improper branch distribution unit orientation risk incomplete valve seating and system performance degradation from potential refrigerant leakage through the electronic expansion valve.

### Note:

*This material is for informational or educational purposes only. It is not intended to be a substitute for professional advice. Consult with your engineer or design professionals for specific applications to your system.*

## Ceiling Mount Installation - Hangers with Hanging Bolt

1. Drill four (4) holes in the ceiling, following the dimensions on the previous pages.
2. Attach the factory-supplied hangers with two (2) screws each at the designated four (4) areas on the frame of the branch distribution unit.
3. Install an anchor in the ceiling, and attach the hanging bolts to the ceiling.
4. Add nuts and washers to the hanging bolt as shown at right.
5. Hang the branch distribution unit on the hanging bolts (ceiling side up), and after checking for level ( $\pm 5$  degrees), securely tighten all nuts.

Figure 17: Branch Distribution Ceiling Mount Installation.

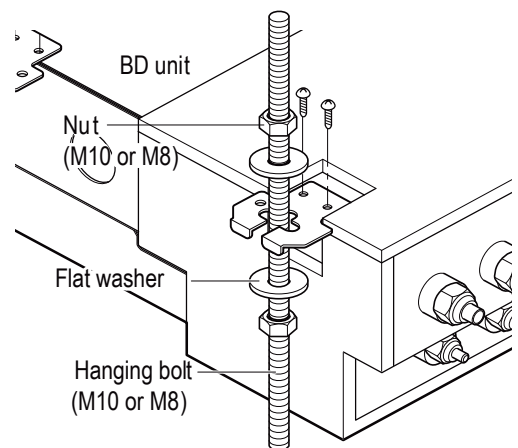

Installation

## Ceiling Mount Installation - Hangers Only

1. Attach the factory-supplied hangers with two (2) screws each at the designated four (4) areas on the frame of the branch distribution unit.
2. Install the branch distribution unit to the ceiling using two screws on each of the hangers as shown below. Unit must be  $\pm 5$  degrees of level.
3. Cover parts of the hanger holes with polyethylene foam insulation (to prevent condensation).

### Note:

*If a screw has been installed on the frame of the branch distribution unit and the screw has been removed, to prevent condensation, either re-install the screw or cover the open hole with aluminum tape.*

Figure 16: Acceptable Branch Distribution Unit Ceiling Mount Orientations.

### Ceiling Mounting Options

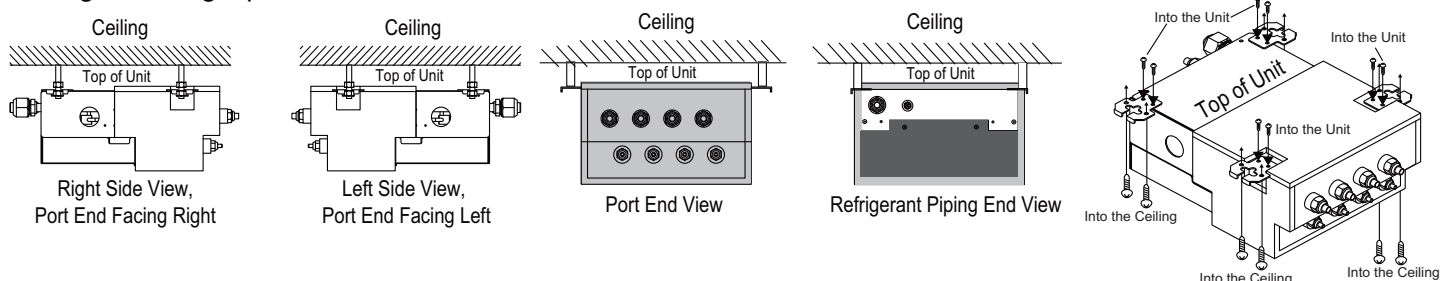

# MOUNTING / ANCHORING THE BRANCH DISTRIBUTION UNITS

MULTI F WITH LGRED<sup>®</sup>  
MULTI F MAX

## Wall Mount Installation - Hangers Only

1. Attach the factory-supplied hangers with two (2) screws each at the designated four (4) areas on the frame of the branch distribution unit.
2. Install the branch distribution unit to the wall using two screws on each of the hangers. Unit must be  $\pm 5$  degrees of level.
3. Cover parts of the hanger holes with polyethylene foam insulation (to prevent condensation).

Figure 19: Acceptable Branch Distribution Unit Wall Mount Orientations.

### Wall Mounting Options

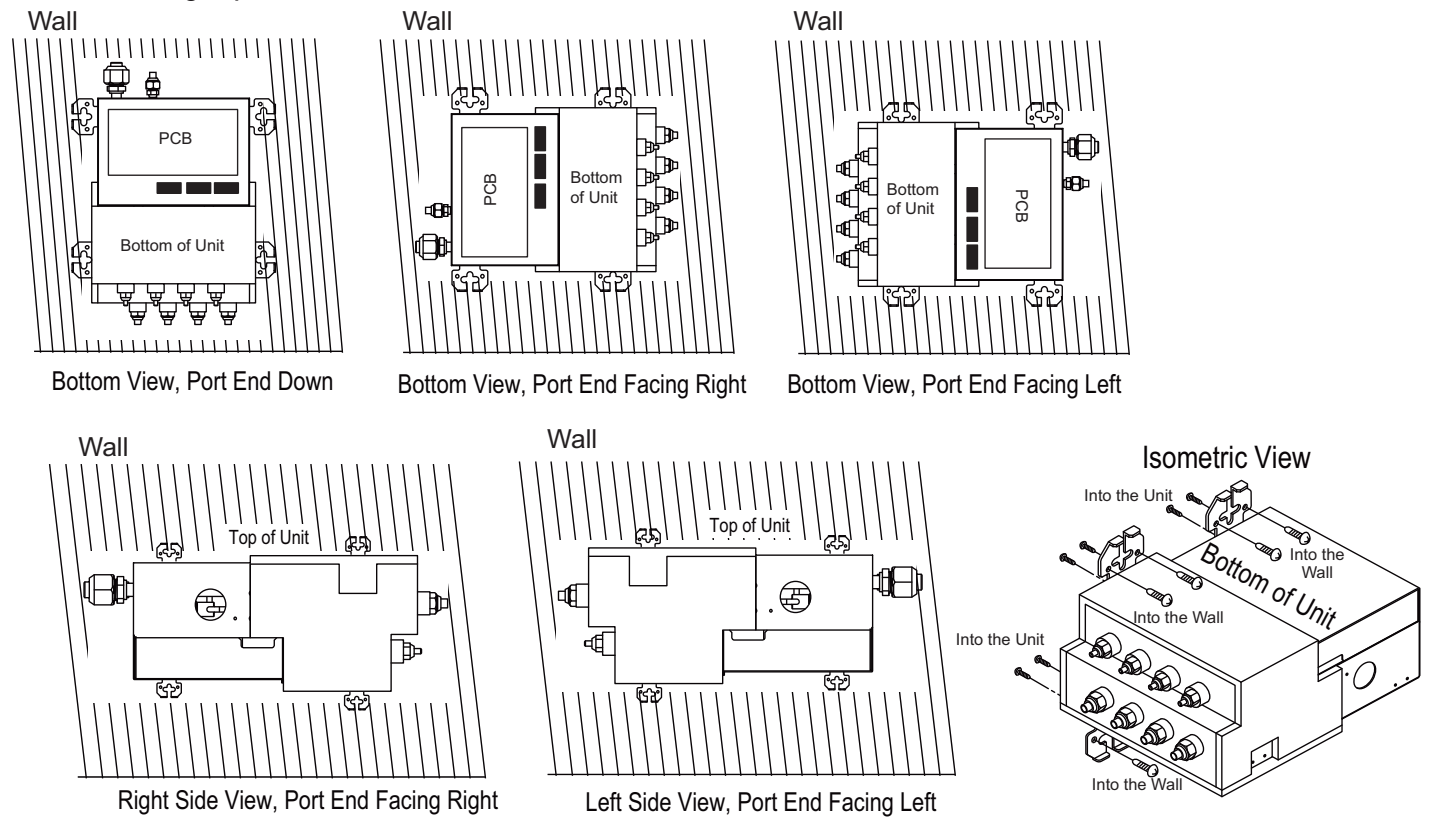
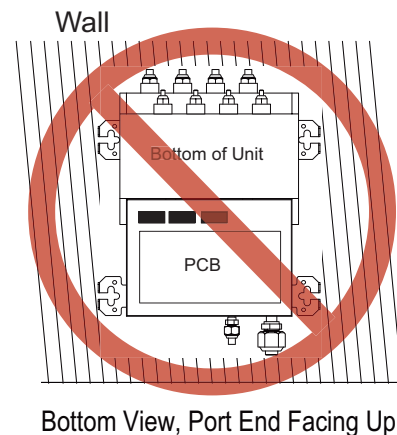

Figure 18: Unacceptable Branch Distribution Unit Orientation.



## LG Air Conditioner Technical Solution (LATS) Software

A properly designed and installed refrigerant piping system is critical to the optimal performance of LG air-conditioning systems. To assist engineers, LG offers, free of charge, LG Air Conditioner Technical Solution (LATS) software—a total design solution for LG air conditioning systems.

### Note:

To reduce the risk of designing an improper applied system or one that will not operate correctly, LG prefers that LATS software be used on all projects.

### Formats

LATS is available to LG customers in three user interfaces: LATS HVAC, LATS CAD2, and LATS Revit. All three LATS formats are available through [www.myLGHVAC.com](http://www.myLGHVAC.com), or contact an LG Sales Representative.

**LATS HVAC** is a Windows®-based application that aids engineers in designing LG Variable Refrigerant Flow (VRF), Multi F / Multi F MAX, Multi F / Multi F MAX with LGRED, Single-Zone, and Energy Recovery Ventilator (ERV) systems.

\*Windows® is a registered mark of Microsoft® Corporation.

**LATS CAD2** combines the LG LATS program with AutoCAD® software\*\*. It permits engineers to layout and validate LG Multi V Variable Refrigerant Flow (VRF), Multi F / Multi F MAX, Multi F / Multi F MAX with LGRED, Single-Zone, and Energy Recovery Ventilator (ERV) systems directly into CAD drawings.

**LATS Revit** integrates the LG LATS program with Revit® software\*\*. It permits engineers to layout and validate Multi V VRF systems directly into Revit drawings.

\*\*AutoCAD® and Revit® are both registered marks of Autodesk, Inc.

### Features

All LG product design criteria have been loaded into the program, making LATS simple to use: double click or drag and drop the component choices. Build systems in Tree Mode where the refrigerant system can be viewed. Switch to a Schematic diagram to see the electrical and communications wiring.

LATS software permits the user to input region data, indoor and outdoor design temperatures, modify humidity default values, zoning, specify type and size of outdoor units and indoor units, and input air flow and external static pressure (ESP) for ducted indoor units.

The program can also:

- Import building loads from a separate Excel file.
- Present options for outdoor unit auto selection.
- Automatically calculate component capacity based on design conditions for the chosen region.
- Verify if the height differences between the various system components are within system limits.
- Provide the correct size of each refrigerant piping segment and LG Y-Branches and Headers.
- Adjust overall piping system length when elbows are added.
- Check for component piping limitations and flag if any parameters are broken.
- Factor operation and capacity for defrost operation.
- Calculate refrigerant charge, noting any additional trim charge.
- Suggest accessories for indoor units and outdoor units.
- Run system simulation.

### Note:

Features depend on which LATS program is being used, and the type of system being designed.

Figure 20: Example of LATS CAD2.



# LG AIR CONDITIONER TECHNICAL SOLUTION (LATS)

MULTI F WITH LGRED°  
MULTI F MAX

## LATS Generates a Complete Project Report

LATS software also generates a report containing project design parameters, cooling and heating design data, system component performance, and capacity data. The report includes system combination ratio and refrigerant charge calculations; and provides detailed bill of material, including outdoor units, indoor units, control devices, accessories, refrigerant pipe sizes segregated by building, by system, by pipe size, and by pipe segments. LATS can generate an Excel GERP report that can imported into the LG SOPS pricing and ordering system.

## Proper Design to Install Procedure

LG encourages a two report design-to-install-procedure. After the design engineer determines building / zone loads and other details, the engineer opens the LATS program and inputs the project's information. When the design is complete, the "Auto Piping" and "System Check" functions must be used to verify piping sizes, limitations, and if any design errors are present. If errors are found, engineers must adjust the design, and run Auto Piping and System Check again. When the design passes the checks, then the engineer prints out a project "Shop Drawing" (LATS Tree Diagram) and provides it to the installing contractor. The contractor must follow the LATS Tree Diagram when building the piping system, but oftentimes the design changes on the building site:

- Architect has changed location and/or purpose of room(s).
- Outdoor unit cannot be placed where originally intended.
- Structural elements prevent routing the piping as planned.
- Air conditioning system conflicts with other building systems (plumbing, gas lines, etc.).

The contractor must mark any deviation from the design on the Shop Drawing, including as-built straight lines and elbows. This "Mark Up" drawing must be returned to the design engineer or Rep, who must input contractor changes into the LATS file. (Copy the original LATS software file, save and rename as a separate file, and modify all piping lengths by double-clicking on each length and editing information.) Like the shop drawing, the Auto Piping and System Check must also be run on this new "As Built" drawing. The design engineer or Rep must then provide the final As Built file to the contractor. The Mark Up version must be compared to the As Built version for:

- Differences in pipe diameter(s). If incorrect diameters have been installed, the piping must be changed out. If pipe diameters have changed, check to see if Y-Branches will also need to be changed.
- Changes to outdoor unit and indoor unit capacities. Capacities changes will impact line length changes.
- Additional refrigerant charge quantity ("Trim Charge"). Trim charge will change if piping lengths and diameters change. The As Built version must reflect installed piping lengths to ensure correct trim charge.

All documents submitted by the contractor, as well as the Shop Drawing and the As Built Drawing files must be provided for commissioning purposes. Model and serial numbers for all system components must also be submitted. If the steps previously detailed are not followed, and all documents are not provided to the commissioning agent, the project runs the risk of not being commissioned and voiding any limited warranty LG offers on the equipment.

## Note:

Contact your LG representative for the vest software program for your application.

Figure 21: Example of a LATS Tree Diagram.

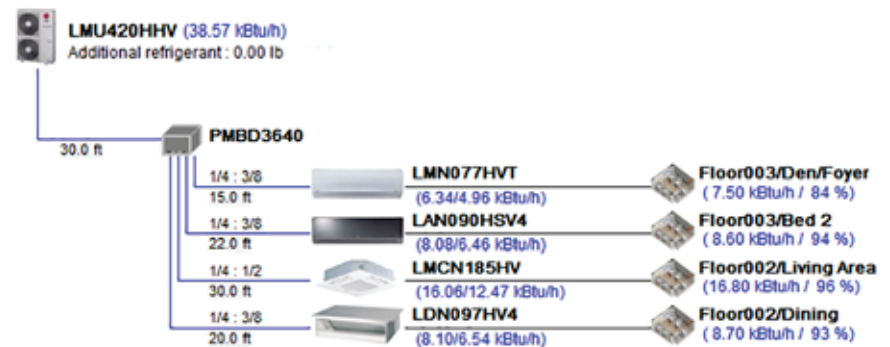

## Refrigerant Safety Standards

ASHRAE Standards 15-2010 and 34-2010 address refrigerant safety and the maximum allowable concentration of refrigerant in an occupied space. Refrigerant will dissipate into the atmosphere, but a certain volume of air is required to safely dissipate the refrigerant. For R410A refrigerant, the maximum allowable concentration of refrigerant is 26 lbs./1,000 cubic feet (Addendum L modified the RCL to 26) of occupied spaces. Buildings with 24-hour occupancy allow half of that concentration.

If a VRF system develops a refrigerant leak, the entire refrigerant charge of the system will dump into the area where the leak occurs. To meet ASHRAE Standards 15 and 34, the smallest room volume on the system must be calculated and compared to the maximum allowable concentration. If the concentration level is higher than allowed, the following are some design suggestions to eliminate the problem:

- Split dual-frame and triple-frame systems into single-frame systems that have lower refrigerant charges.
- Add transfer grilles in the ceiling or walls of the smaller rooms to increase the volume of the room.
- Remove the smallest space from the system and serve it with a smaller mini-split system.

## Device Connection Limitations

• The minimum number of connected and operating indoor units to Multi F / Multi F MAX with LGRED systems is two, taking into consideration the minimum combination ratio.

• The maximum number of indoor units for each Multi F / Multi F MAX with LGRED heat pump system is:

LMU180HHV = 2      LMU240HHV = 3      LMU300HHV = 4      LMU361HHV = 5      LMU421HHV = 6      LMU480HHV = 8

### Note:

For allocated capacity information, see the combination tables in the "Multi F / Multi F MAX with LGRED Combination Data Manual" on [www.lghvac.com](http://www.lghvac.com). For performance data, see "Multi F / Multi F MAX with LGRED Performance Data Manual" on [www.lghvac.com](http://www.lghvac.com).

One of the most critical elements of multi-zone systems is the refrigerant piping. See below and the following page for pipe length limits that must be followed in the design of Multi F and Multi F MAX with LGRED refrigerant pipe systems:

## Multi F with LGRED Outdoor Unit Piping Length and Elevation Limitations

Figure 22: Multi F Refrigerant Piping System Limitations (LMU180HHV Example).

Table 11: Multi F with LGRED Outdoor Unit Refrigerant Piping System Limitations.

Outdoor Unit Model (Btu/h)	LMU180HHV / 18,000	LMU240HHV / 24,000	LMU300HHV / 30,000
Max. Total System Piping Length (ft.)	164 A+B	246.1 A+B+C	246.1 A+B+C+D
Min. Length for One Branch (ft.)	9.8	9.8	9.8
Max. Length for One Branch (ft.)	82	82	82
Max. Elevation Between Each Indoor Unit and Outdoor Unit (h1)	49.2	49.2	49.2
Max. Elevation Between Indoor Units (h2)	24.6	24.6	24.6
Max. Combination of Indoor Units	24,000	33,000	40,000

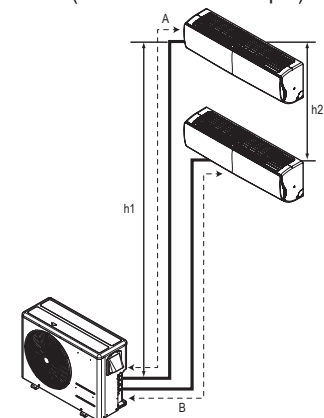

## Example of a Multi F with LGRED System

Example: LMU300HHV outdoor unit with four (4) indoor units connected.

ODU: Outdoor Unit.

IDU: Indoor Unit.

A, B, C, D: Pipes from Outdoor Unit to Indoor Unit.

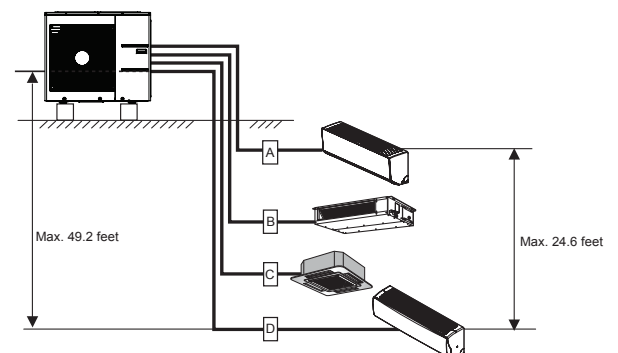

# REFRIGERANT SAFETY STANDARDS / DEVICE CONNECTION LIMITATIONS

MULTI F WITH LGRED<sup>®</sup>  
MULTI F MAX

## Multi F MAX with LGRED Outdoor Unit Piping Length and Elevation Limitations

Table 12: Multi F MAX with LGRED Outdoor Unit Refrigerant Piping System Limitations.

Pipe Length (ELF = Equivalent Length of pipe in Feet)	Total piping length ( $\Sigma A + \Sigma B$ )		≤475.7 feet
	Main pipe (Outdoor Unit to Branch Distribution Units: A)	Minimum for Each (A) Piping Segment	
Maximum ( $\Sigma A$ )			≤180.4 feet
Total branch piping length ( $\Sigma B$ )			≤295.3 feet
	Branch pipe (Branch Distribution Units to Indoor Units: B)	Minimum	16.4 feet
Maximum		≤49.2 feet	
Elevation Differential (All Elevation Limitations are Measured in Actual Feet)	If outdoor unit is above or below indoor unit (h1)		≤98.4 feet
	Between the farthest two indoor units (h2)		≤49.2 feet
	Between branch distribution unit and farthest connected indoor unit(s) (h3)		≤32.8 feet
	Between branch distribution units (h4)		≤49.2 feet
Max. Combination of IDUs	LMU361HHV = 48,000	LMU421HHV = 56,000	LMU480HHV = 65,000

Figure 23: Multi F MAX Refrigerant Piping System Limitations.

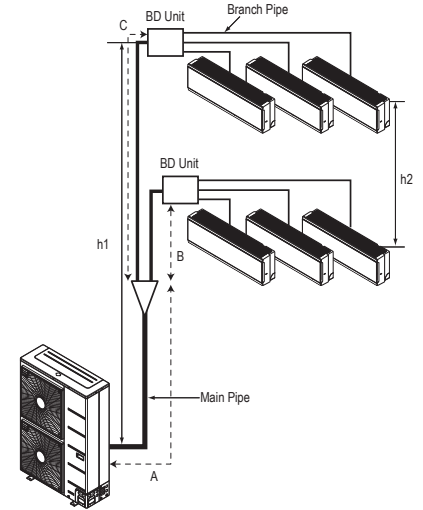

Table 13: Multi F MAX with LGRED Piping Sizes.

Piping	Main Pipe A (inch)	Branch Pipe B
Liquid	Ø3/8	Depends on the size of the indoor unit piping
Gas	Ø3/4	

## Example of a Multi F MAX with LGRED System with Two Branch Distribution Units

Example: LMU421HHV outdoor unit with six (6) indoor units and two (2) branch distribution units connected.

ODU: Outdoor Unit.

IDU: Indoor Unit.

BD: Branch Distribution Unit(s).

A: Main Pipe.

B: Branch Pipe (Branch Distribution Unit[s] to Indoor Unit[s]).

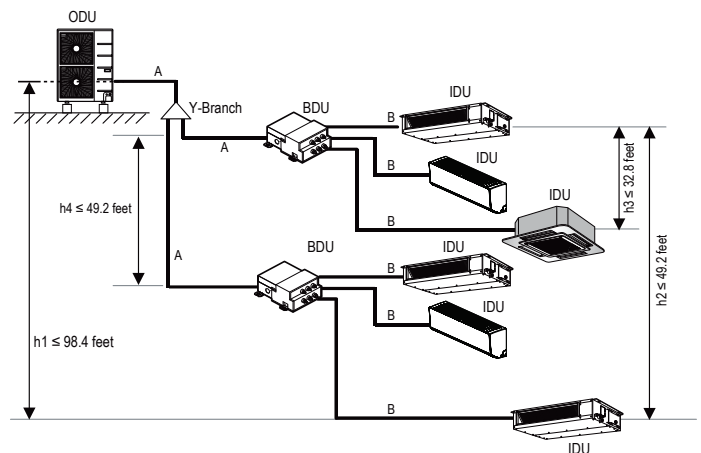

## Using Refrigerant Components

Field-supplied elbows are allowed as long as they are designed for use with R410A refrigerant. The designer, however, must be cautious with the quantity and size of fittings used, and must account for the additional pressure losses in equivalent pipe length calculation for each branch. The equivalent pipe length of each elbow must be added to each pipe segment.

Table 14: Equivalent Piping Length for Elbows, Y-branches, and Branch Distribution Units.

Component	Size (Inches)				
	1/4	3/8	1/2	5/8	3/4
Elbow (ft.)	0.5	0.6	0.7	0.8	1.2
Y-Branch Kit (ft., Multi F MAX with LGRED systems only) <sup>1</sup>	1.6				
Branch Distribution Unit (ft., Multi F MAX with LGRED systems only)	8.2				

<sup>1</sup>Kit contains two Y-branches: one for liquid and one for vapor.

## Selecting Field-Supplied Copper Piping

### Note:

Always follow local codes when selecting and installing copper pipe and piping system components.

Approved piping for use with LG HVAC products will be marked "R410 RATED" along the length of the pipe. Piping wall thickness must meet local code requirements and be approved for a maximum operating pressure of 551 psi. When bending piping, try to keep the number of bends to a minimum, and use the largest radii possible to reduce the equivalent length of installed piping; also, bending radii greater than ten (10) piping diameters can minimize pressure drop. Be sure no traps or sags are present.

### For Multi-Zone Split Systems

Use ACR copper piping rated at the system working pressure (rated for R410A refrigerant).

### Note:

Always properly support the piping as per the instructions on page 41.

Table 15: ACR Rated Copper Tubing Material.

Type	Seamless Phosphorous Deoxidized
Class	UNS C12200 DHP
Straight Lengths	H58 Temper
Coils	O60 Temper

Table 16: ACR Rated Piping Wall Thicknesses.

OD (in)	1/4	3/8	1/2	5/8	3/4	7/8	1-1/8	1-3/8	1-5/8
Material	Rigid or Soft ACR Rated for R410A			Rigid or Soft ACR Rated for R410A					
Min. Bend Radius (in)	0.563	0.9375	1.5	2.25	3.0	3.0	3.5	4.0	4.5
Min. Wall Thickness (in)	0.03	0.03	0.03	0.03	0.03	0.03	0.03	0.04	0.050

Table 17: ACR Copper Tubing Dimensions and Physical Characteristics<sup>1-3</sup>.

Nominal Pipe Outside Diameter (in)	Actual Outside Diameter (in)	Tempered (Hard Drawn)			Annealed (Soft)		
		Nominal Wall Thickness (in)	Weight (lb/ft)	Cubic ft per Linear ft	Nominal Wall Thickness (in)	Weight (lb/ft)	Cubic ft per Linear ft
1/4	0.250	--	--	--	0.030	0.081	0.00020
3/8	0.375	0.030	0.126	0.00054	0.032	0.134	0.00053
1/2	0.500	0.035	0.198	0.00101	0.032	0.182	0.00103
5/8	0.625	0.040	0.285	0.00162	0.035	0.251	0.00168
3/4	0.750	0.042	0.362	0.00242	0.042	0.362	0.00242
7/8	0.875	0.045	0.455	0.00336	0.045	0.455	0.00336
1-1/8	1.125	0.050	0.655	0.00573	0.050	0.655	0.00573
1-3/8	1.375	0.055	0.884	0.00875	0.055	0.884	0.00875
1-5/8	1.625	0.060	1.14	0.0124	0.060	1.14	0.0124

<sup>1</sup>All dimensions provided are in accordance with ASTM B280 – Standard.

<sup>2</sup>Design pressure = 551 psig.

<sup>3</sup>The Copper Tube Handbook, 2016, Copper Development Association Inc., 260 Madison Avenue, New York, NY 10016.

### Note:

- Commercially available piping often contains dust and other materials. Always blow it clean with a dry nitrogen.
- Prevent dust, water or other contaminants from entering the piping during installation.

# COPPER EXPANSION AND CONTRACTION

## Copper Expansion and Contraction

Under normal operating conditions, the vapor pipe temperature of a Multi F with LGRED system can vary as much as 180°F. With this large variance in pipe temperature, the designer must consider pipe expansion and contraction to avoid pipe and fitting fatigue failures.

Refrigerant pipe along with the insulation jacket form a cohesive unit that expands and contracts together. During system operation, thermal heat transfer occurs between the pipe and the surrounding insulation.

If the pipe is mounted in free air space, no natural restriction to movement is present if mounting clamps are properly spaced and installed. When the refrigerant pipe is mounted underground in a utility duct stacked among other pipes, natural restriction to linear movement is present. In extreme cases, the restrictive force of surface friction between insulating jackets could become so great that natural expansion ceases and the pipe is “fixed” in place. In this situation, opposing force caused by change in refrigerant fluid/vapor temperature can lead to pipe/fitting stress failure.

The refrigerant pipe support system must be engineered to allow free expansion to occur. When a segment of pipe is mounted between two fixed points, provisions must be provided to allow pipe expansion to naturally occur. The most common method is the inclusion of expansion Loop or U-bends mounted in the horizontal plane. When expansion loops are placed in a vertical riser, the loop is to be formed in a horizontal fashion resulting in a torsional movement during expansion and contraction. Each segment of pipe has a natural fixed point where no movement occurs. This fixed point is located at the center point of the segment assuming the entire pipe is insulated in a similar fashion. The natural fixed point of the pipe segment is typically where the expansion Loop or U-bend must be. Linear pipe expansion can be calculated using the following formula:

$$LE = C \times L \times (T_r - T_a) \times 12$$

LE	=	Anticipated linear tubing expansion (in.)
C	=	Constant (For copper = $9.2 \times 10^{-6}$ in./in.°F)
L	=	Length of pipe (ft.)
$T_r$	=	Refrigerant pipe temperature (°F)
$T_a$	=	Ambient air temperature (°F)
12	=	Inches to feet conversion (12 in./ft.)

1. From the table “Linear Thermal Expansion of Copper Tubing in Inches,” find the row corresponding with the actual length of the straight pipe segment.
2. Estimate the minimum and maximum temperature of the pipe. Typical pipe temperature change ranges: High Pressure Vapor: ambient temperature to 215°F; Low Pressure Vapor: ambient to 35°F; Liquid pipe: ambient, 80°F, 110°F. Choose the two most extreme. In the column showing the minimum pipe temperature, look up the anticipated expansion distance. Do the same for the maximum pipe temperature.
3. Calculate the difference in the two expansion distance values. The result will be the anticipated change in pipe length.

### General Example:

A system is installed and the design shows that there is a 100 foot straight segment of tubing between a Y-branch and a branch distribution unit. The system operates 24 hours per day. In heating, this pipe transports hot gas vapor to the indoor units at 120°F. In cooling, the same tube is a suction line returning refrigerant vapor to the outdoor unit at 40°F. Look up the copper tubing expansion at each temperature and calculate the difference.

### Vapor Line

Transporting Hot Vapor: 100 ft. pipe at 120°F = 1.40 in.  
Transporting Suction Vapor: 100 ft. pipe at 40°F = 0.40 in.  
Anticipated Change in Length: 1.40 in. – 0.40 in. = 1.00 in.

### Liquid Line

The liquid temperature remains relatively the same temperature; only the direction of flow will reverse. Therefore, no significant change in length of the liquid line is anticipated.

When creating an expansion joint, the joint depth must be a minimum of two times the joint width. Although different types of expansion arrangements are available, the data for correctly sizing an expansion loop is provided in the table “Coiled Expansion Loops and Offsets (Plan View).” Use soft copper with long radius bends on longer runs or long radius elbows for shorter pipe segments. Using the anticipated linear expansion (LE) distance calculated, look up the Expansion Loop or U-bend minimum design dimensions. If other types of expansion joints are chosen, design per ASTM B-88 Standards.

**To find the anticipated expansion value:**

1. From the table below, find the row corresponding with the actual feet of the straight pipe segment.
2. Estimate the minimum and maximum temperature of the pipe.
3. In the column showing the minimum pipe temperature, look up the anticipated expansion distance corresponding to the segment length. Do the same for the maximum pipe temperature.
4. Calculate the difference in the two expansion distance values. The result will be the change in pipe length.

Table 18: Linear Thermal Expansion of Copper Tubing in Inches.

Pipe Length <sup>1</sup>	Fluid Temperature °F																			
	35°	40°	45°	50°	55°	60°	65°	70°	75°	80°	85°	90°	95°	100°	105°	110°	115°	120°	125°	130°
10	0.04	0.04	0.05	0.06	0.06	0.07	0.08	0.08	0.09	0.09	0.10	0.10	0.11	0.11	0.11	0.12	0.13	0.14	0.15	0.15
20	0.08	0.08	0.10	0.12	0.13	0.14	0.15	0.16	0.17	0.18	0.19	0.20	0.21	0.22	0.22	0.23	0.26	0.28	0.29	0.30
30	0.12	0.12	0.15	0.18	0.20	0.21	0.23	0.24	0.26	0.27	0.29	0.30	0.32	0.33	0.32	0.35	0.39	0.42	0.44	0.45
40	0.16	0.16	0.20	0.24	0.26	0.28	0.30	0.32	0.34	0.36	0.38	0.40	0.42	0.44	0.43	0.46	0.52	0.56	0.58	0.60
50	0.20	0.20	0.25	0.30	0.33	0.35	0.38	0.40	0.43	0.45	0.48	0.50	0.53	0.55	0.54	0.58	0.65	0.70	0.73	0.75
60	0.24	0.24	0.30	0.36	0.39	0.42	0.45	0.48	0.51	0.54	0.57	0.60	0.63	0.66	0.65	0.69	0.78	0.84	0.87	0.90
70	0.28	0.28	0.35	0.42	0.46	0.49	0.53	0.56	0.60	0.63	0.67	0.70	0.74	0.77	0.76	0.81	0.91	0.98	1.02	1.05
80	0.32	0.32	0.40	0.48	0.52	0.56	0.60	0.64	0.68	0.72	0.76	0.80	0.84	0.88	0.86	0.92	1.04	1.12	1.16	1.20
90	0.36	0.36	0.45	0.54	0.59	0.63	0.68	0.72	0.77	0.81	0.86	0.90	0.95	0.99	0.97	1.04	1.17	1.26	1.31	1.35
100	0.40	0.40	0.50	0.60	0.65	0.70	0.75	0.80	0.85	0.90	0.95	1.00	1.05	1.10	1.08	1.15	1.30	1.40	1.45	1.50
120	0.48	0.48	0.60	0.72	0.78	0.84	0.90	0.96	1.02	1.08	1.14	1.20	1.26	1.32	1.30	1.38	1.56	1.68	1.74	1.80
140	0.56	0.56	0.70	0.84	0.91	0.98	1.05	1.12	1.19	1.26	1.33	1.40	1.47	1.54	1.51	1.61	1.82	1.96	2.03	2.10
160	0.64	0.64	0.80	0.96	1.04	1.12	1.20	1.28	1.36	1.44	1.52	1.60	1.68	1.76	1.73	1.84	2.08	2.24	2.32	2.40
180	0.72	0.72	0.90	1.08	1.17	1.26	1.35	1.44	1.53	1.62	1.71	1.80	1.89	1.98	1.94	2.07	2.34	2.52	2.61	2.70
200	0.80	0.80	1.00	1.20	1.30	1.40	1.50	1.60	1.70	1.80	1.90	2.00	2.10	2.20	2.16	2.30	2.60	2.80	2.90	3.00
220	0.88	0.88	1.10	1.32	1.43	1.54	1.65	1.76	1.87	1.98	2.09	2.20	2.31	2.42	2.38	2.53	2.86	3.08	3.19	3.30
240	0.96	0.96	1.20	1.44	1.56	1.68	1.80	1.92	2.04	2.16	2.28	2.40	2.52	2.64	2.59	2.76	3.12	3.36	3.48	3.60
260	1.04	1.04	1.30	1.56	1.69	1.82	1.95	2.08	2.21	2.34	2.47	2.60	2.73	2.86	2.81	2.99	3.38	3.64	3.77	3.90
280	1.12	1.12	1.40	1.68	1.82	1.96	2.10	2.24	2.38	2.52	2.66	2.80	2.94	3.08	3.02	3.22	3.64	3.92	4.06	4.20
300	1.20	1.20	1.50	1.80	1.95	2.10	2.25	2.40	2.55	2.70	2.85	3.00	3.15	3.30	3.24	3.45	3.90	4.20	4.35	4.50
320	1.28	1.28	1.60	1.92	2.08	2.24	2.40	2.56	2.72	2.88	3.04	3.20	3.36	3.52	3.46	3.68	4.16	4.48	4.64	4.80
340	1.36	1.36	1.70	2.04	2.21	2.38	2.55	2.72	2.89	3.06	3.23	3.40	3.57	3.74	3.67	3.91	4.42	4.76	4.93	5.10
360	1.44	1.44	1.80	2.16	2.34	2.52	2.70	2.88	3.06	3.24	3.42	3.60	3.78	3.96	3.89	4.14	4.68	5.04	5.22	5.40
380	1.52	1.52	1.90	2.28	2.47	2.66	2.85	3.04	3.23	3.42	3.61	3.80	3.99	4.18	4.10	4.37	4.94	5.32	5.51	5.70
400	1.60	1.60	2.00	2.40	2.60	2.80	3.00	3.20	3.40	3.60	3.80	4.00	4.20	4.40	4.32	4.60	5.20	5.60	5.80	6.00
420	1.68	1.68	2.10	2.52	2.73	2.94	3.15	3.36	3.57	3.78	3.99	4.20	4.41	4.62	4.54	4.83	5.46	5.88	6.09	6.30
440	1.76	1.76	2.20	2.64	2.86	3.08	3.30	3.52	3.74	3.96	4.18	4.40	4.62	4.84	4.75	5.06	5.72	6.16	6.38	6.60
460	1.84	1.84	2.30	2.76	2.99	3.22	3.45	3.68	3.91	4.14	4.37	4.60	4.83	5.06	4.97	5.29	5.98	6.44	6.67	6.90
480	1.92	1.92	2.40	2.88	3.12	3.36	3.60	3.84	4.08	4.32	4.56	4.80	5.04	5.28	5.18	5.52	6.24	6.72	6.96	7.20
500	2.00	2.00	2.50	3.00	3.25	3.50	3.75	4.00	4.25	4.50	4.75	5.00	5.25	5.50	5.40	5.75	6.50	7.00	7.25	7.50

<sup>1</sup>Pipe length baseline temperature = 0°F. "Expansion of Carbon, Copper and Stainless Steel Pipe," *The Engineers' Toolbox*, [www.engineeringtoolbox.com](http://www.engineeringtoolbox.com).

# COPPER EXPANSION AND CONTRACTION

MULTI F WITH LGRED<sup>®</sup>  
MULTI F MAX

Figure 24: Coiled Expansion Loops and Offsets (Plan View).

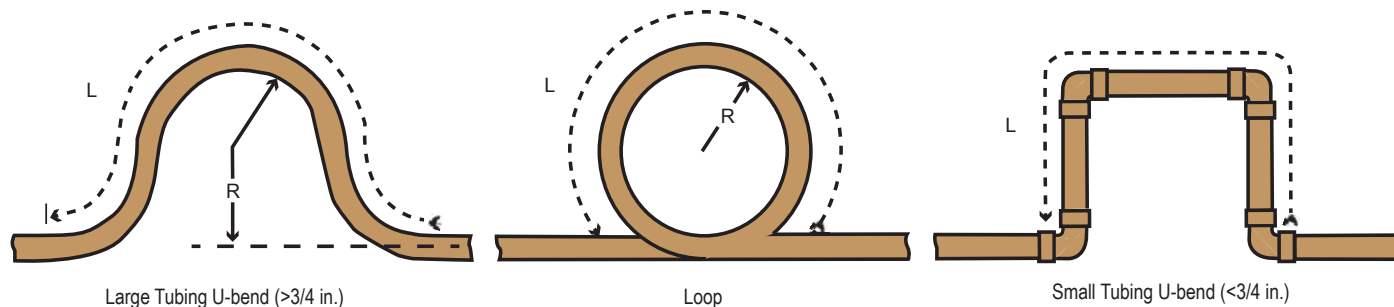

## Note:

All expansion loops and offsets must be installed in the horizontal plane to prevent the possibility of trapping oil. Loops and offsets in vertical risers must also be installed in a horizontal plane.

Table 19: Radii of Coiled Expansion Loops and Developed Lengths of Expansion Offsets.

Anticipated Linear Expansion (LE) (in.)		Nominal Tube Size (OD) inches						
		1/4	3/8	1/2	3/4	1	1-1/4	1-1/2
1/2	R <sup>1</sup>	6	7	8	9	11	12	13
	L <sup>2</sup>	38	44	50	59	67	74	80
1	R <sup>1</sup>	9	10	11	13	15	17	18
	L <sup>2</sup>	54	63	70	83	94	104	113
1-1/2	R <sup>1</sup>	11	12	14	16	18	20	22
	L <sup>2</sup>	66	77	86	101	115	127	138
2	R <sup>1</sup>	12	14	16	19	21	23	25
	L <sup>2</sup>	77	89	99	117	133	147	160
2-1/2	R <sup>1</sup>	14	16	18	21	24	26	29
	L <sup>2</sup>	86	99	111	131	149	165	179
3	R <sup>1</sup>	15	17	19	23	26	29	31
	L <sup>2</sup>	94	109	122	143	163	180	196
3-1/2	R <sup>1</sup>	16	19	21	25	28	31	34
	L <sup>2</sup>	102	117	131	155	176	195	212
4	R <sup>1</sup>	17	20	22	26	30	33	36
	L <sup>2</sup>	109	126	140	166	188	208	226

<sup>1</sup>R = Centerline Length of Pipe.

<sup>2</sup>L = Centerline Minimum Radius (inches).

## Piping Handling

Pipes used for the refrigerant piping system must include the specified thickness, and the interior must be clean.

While handling and storing, Ⓞ do not bend or damage the pipes, and take care not to contaminate the interior with dust, moisture, etc.

Keep Pipes Capped While Storing.

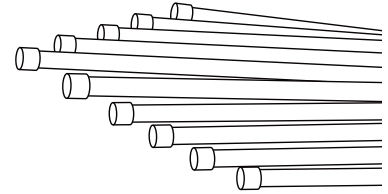

Keep refrigerant pipe dry, clean, and airtight.

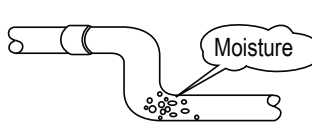
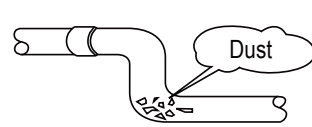
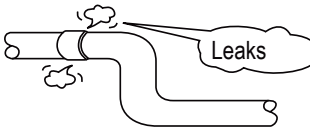
	Dry	Clean	Airtight
	No moisture should be inside the piping. 	No dust should be inside the piping. 	No leaks should occur. 
<b>Possible Problems</b>	<ul style="list-style-type: none"> <li>- Significant hydrolysis of refrigerant oil.</li> <li>- Refrigerant oil degradation.</li> <li>- Poor insulation of the compressor.</li> <li>- System does not operate properly.</li> <li>- EEVs, capillary tubes are clogged.</li> </ul>	<ul style="list-style-type: none"> <li>- Refrigerant oil degradation.</li> <li>- Poor insulation of the compressor.</li> <li>- System does not operate properly.</li> <li>- EEVs and capillary tubes become clogged.</li> </ul>	<ul style="list-style-type: none"> <li>- Refrigerant gas leaks / shortages.</li> <li>- Refrigerant oil degradation.</li> <li>- Poor insulation of the compressor.</li> <li>- System does not operate properly.</li> </ul>
<b>Solutions</b>	<ul style="list-style-type: none"> <li>- Remove moisture from the piping.</li> <li>- Piping ends should remain capped until connections are complete.</li> <li>- Ⓞ Do not install piping on a rainy day.</li> <li>- Connect piping properly at the unit's side.</li> <li>- Remove caps only after the piping is cut, the burrs are removed, and after passing the piping through the walls.</li> <li>- Evacuate system to a maximum of 500 microns and insure the vacuum holds at that level for 1 hour.</li> </ul>	<ul style="list-style-type: none"> <li>- Remove dust from the piping.</li> <li>- Piping ends should remain capped until connections are complete.</li> <li>- Connect piping properly at the side of the unit.</li> <li>- Remove caps only after the piping is cut and burrs are removed.</li> <li>- Retain the cap on the piping when passing it through walls, etc.</li> </ul>	<ul style="list-style-type: none"> <li>- Test system for air tightness.</li> <li>- Perform brazing procedures that comply with all applicable standards.</li> <li>- Perform flaring procedures that comply with all applicable standards.</li> <li>- Perform flanging procedures that comply with all applicable standards.</li> <li>- Ensure that refrigerant lines are pressure tested to 550 psig and hold for 24 hours.</li> </ul>

Proper system operation depends on the installer using utmost care while assembling the piping system. The following pages are an overview of best practices when installing the refrigerant piping system.

## Note:

LG Electronics U.S.A., Inc., is not responsible for any piping calculations, refrigerant leaks, degradation of performance, any other potential problems or damages caused by the interconnecting piping, their joint connections, isolation valves, or introduced debris inside the piping system.

## ⊘ No Pipe Size Substitutions

Use only the pipe size selected by the LATS HVAC pipe system design software. Using a different size is prohibited and will result in a system malfunction or failure to work at all.

## ⊘ No In-line Refrigeration Components

Components such as oil traps, solenoid valves, filter-driers, sight glasses, tee fittings, and other after-market accessories are ⊘ not permitted on the refrigerant piping system between the outdoor units and the indoor / heat recovery units. LG HVAC systems are provided with redundant systems that make sure oil is properly returned to the compressor. Sight-glasses and solenoid valves will cause vapor to form in the liquid stream. Over time, driers will deteriorate and introduce debris into the system. The designer and installer must verify the refrigerant piping system is free of traps, sagging pipes, sight glasses, filter driers, etc.

## Field-Provided Isolation Ball Valves

LG maintains a neutral position on using isolation valves in LG HVAC refrigerant piping systems. LG does not endorse any manufacturer of isolation valves. It is recognized that installing isolation valves will simplify future maintenance requirements, and, if used, considerations must be taken including, but not limited to, the following:

- Pressure drops for any component used, including isolation valves, must be known in equivalent pipe length and calculated into the total and segment equivalent piping lengths and compared to product design limitations.
- In all cases, materials must be suitable for the application and any applicable codes, including, but not limited to, diameter and wall thickness continuity per ACR standards.

Failure to do so will cause significant performance degradation. Proper leak checks must be performed. Using isolation valves does not automatically void any LG product warranty, however, a limited warranty will be voided in whole or part must any field supplied accessory fail in any way that causes product failure.

## Using Elbows

Field-supplied elbows are allowed if they are long radius and designed for use with R410A refrigerant. The designer and installer, however, must be cautious with the quantity and size of fittings used, and must account for the additional pressure losses in equivalent pipe length calculation for each branch. The equivalent pipe length of each elbow must be added to each pipe segment in the LATS program.

## Pipe Bends

When bending soft copper, use long radius bends. Refer to the “Radii of Coiled Expansion Loops and Developed Lengths of Expansion Offsets” table for minimum radius specifications.

## Obstacles

When an obstacle, such as an I-beam or concrete T, is in the path of the planned refrigerant pipe run, it is best practice to route the pipe over the obstacle. If adequate space is not available to route the insulated pipe over the obstacle, then route the pipe under the obstacle. In either case, it is imperative the length of the horizontal section of pipe above or below the obstacle be a minimum of three (3) times the longest vertical rise (or fall) at either end of the segment.

Figure 25: Installing Piping Above and Below an Obstacle.

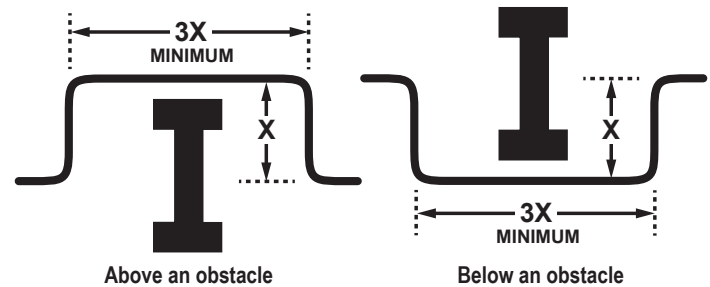

## Pipe Supports

A properly installed pipe system must be adequately supported to avoid pipe sagging. Sagging pipes become oil traps that lead to equipment malfunction.

Pipe supports must  never touch the pipe wall; supports must be installed outside (around) the primary pipe insulation jacket. Insulate the pipe first because pipe supports must be installed outside (around) the primary pipe insulation jacket. Clevis hangers must be used with shields between the hangers and insulation. Field provided pipe supports must be designed to meet local codes. If allowed by code, use fiber straps or split-ring hangers suspended from the ceiling on all-thread rods (fiber straps or split ring hangers can be used as long as they do not compress the pipe insulation). Place a second layer of insulation over the pipe insulation jacket to prevent chafing and compression of the primary insulation in the confines of the support clamp.

A properly installed pipe system will have sufficient supports to avoid pipes from sagging during the life of the system. As necessary, place supports closer for segments where potential sagging could occur. Maximum spacing of pipe supports must meet local codes. If local codes do not specify pipe support spacing, pipe must be supported:

- Maximum of five (5) feet on center for straight segments of pipe up to 3/4 inches outside diameter size.
- Maximum of six (6) feet on center for pipe up to one (1) inch outside diameter size.
- Maximum of eight (8) feet on center for pipe up to two (2) inches outside diameter size.

Wherever the pipe changes direction, place a hanger within twelve (12) inches on one side and within twelve (12) to nineteen (19) inches of the bend on the other side. Support piping at indoor units, Y-branch, and Header fittings as shown.

Figure 26: Pipe Hanger Details.

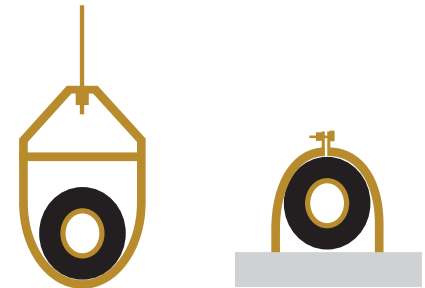

### Note:

Use a 4" + long sheet curved sheet metal saddles between hanger bracket and insulation to promote linear expansion/contraction.

Figure 27: Typical Pipe Support Location—Change in Pipe Direction.

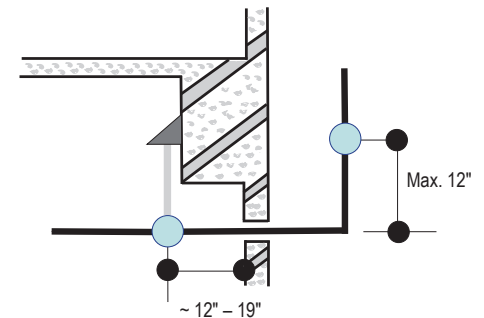

Figure 28: Pipe Support at Indoor Unit.

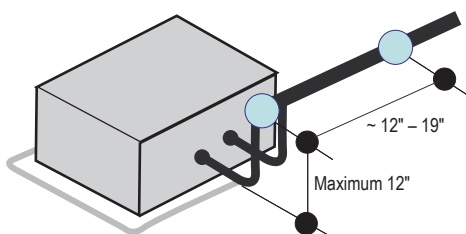

Figure 29: Pipe Support at Y-branch Fitting.

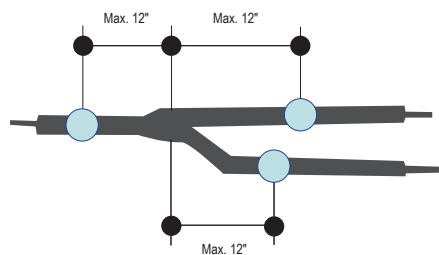
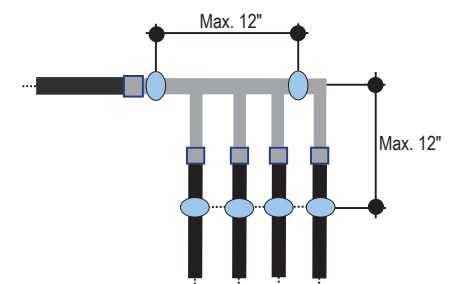

Figure 30: Pipe Support at Header Fitting.



## Examples of Supports

Figure 31: U-Bolt Support with Insulation.

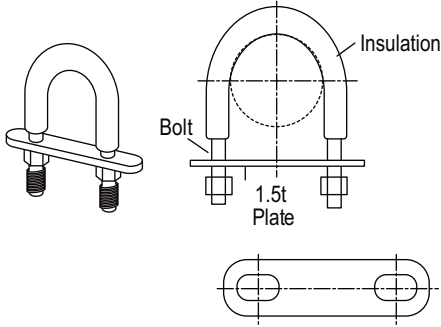

Figure 32: O-Ring Support with Insulation.

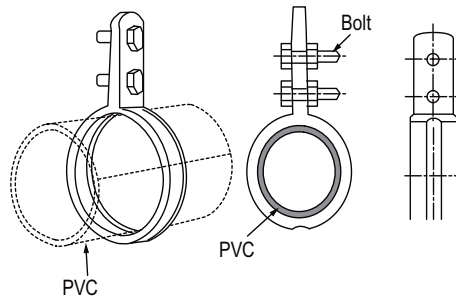
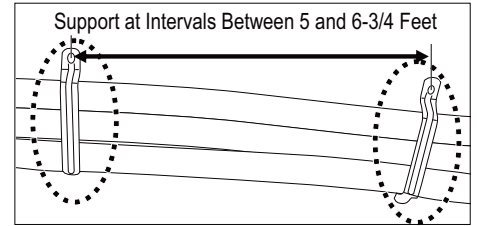

Figure 33: Saddle-Type Support.



*Do not compress the insulation with the saddle-type support. If the insulation is compressed, it will tear open and allow condensation to generate during product operation.*

Figure 34: U-Bolt Support with an Insulated Pipe.

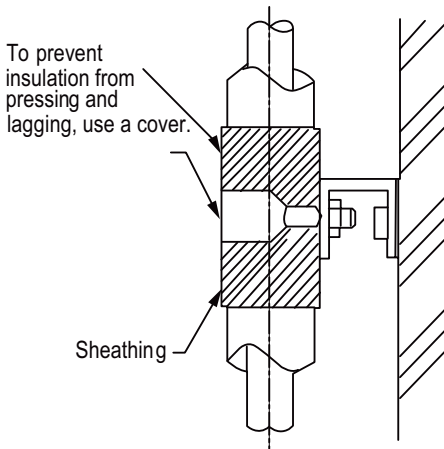

Figure 35: O-Ring Band Support with an Insulated Pipe.



Figure 36: One-Point Down-Stop Support (>441 lbs.).

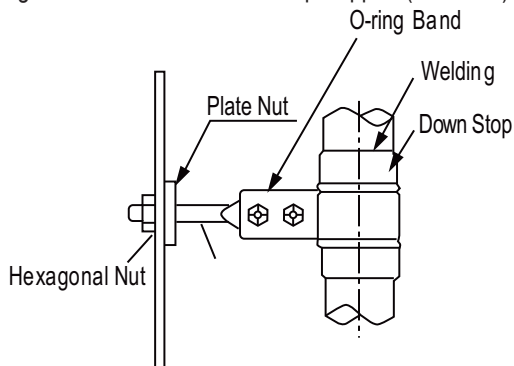
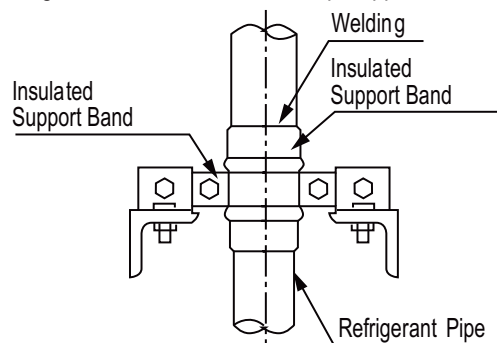

Figure 37: Two-Point Down-Stop Support.



## Pipe Sleeves at Penetrations

LG recommends that all pipe penetrations through walls, floors, and pipes buried underground be properly insulated and routed through an appropriate wall sleeve of sufficient size to prevent compression of refrigerant pipe insulation and promote free movement of the pipe within the sleeve. Use 4"+ curved sheet metal saddles between the bottom surface of the pipe and the bottom surface of the penetration.

Figure 38: Pipe Sleeve Options.

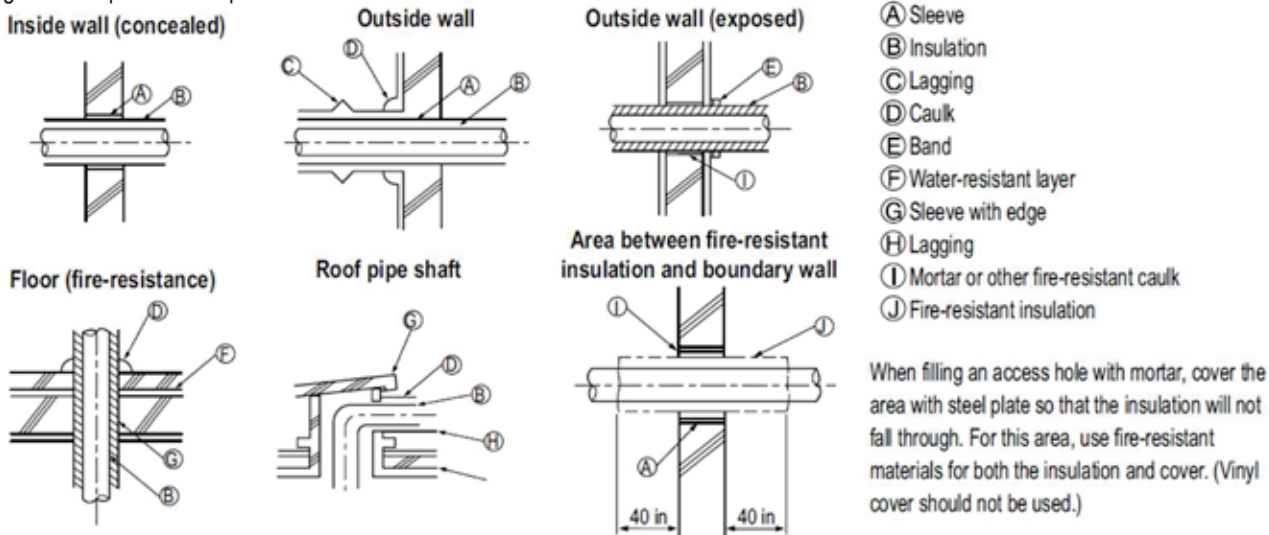

### Note:

Diameter of penetrations must be determined by pipe diameter plus the thickness of the insulation.

## Underground Refrigerant Piping

Refrigerant pipe installed underground must be routed inside a vapor tight protective sleeve to prevent insulation deterioration and water infiltration. Refrigerant pipe installed inside underground casing must be continuous without any joints. Underground refrigerant pipe must be located at a level **below the frost line**.

Table 20: Utility Conduit Sizes.

Liquid Pipe <sup>1</sup>	Vapor Pipe <sup>1</sup>			
	3/8 (2.0 <sup>2,5</sup> )	1/2 (2.0 <sup>2,5</sup> )	5/8 (2-1/8 <sup>2,5</sup> )	3/4 (2-1/4 <sup>2,5</sup> )
1/4 (1.0) <sup>3</sup>	4	4	4	4
3/8 (1-1/8) <sup>3</sup>	4	4	4	5
1/2 (1-1/2) <sup>4</sup>	5	5	5	5
5/8 (1-5/8) <sup>4</sup>	5	5	5	5
3/4 (1-3/4) <sup>4</sup>	5	5	5	5

<sup>1</sup>OD pipe diameter in inches; Values in parenthesis ( ) indicate OD of pipe with insulation jacket.

<sup>2</sup>Diameter of pipe with insulation. Thickness of pipe insulation is typical. Actual required thickness will vary based on surrounding ambient conditions and must be calculated and specified by the design engineer.

<sup>3</sup>Insulation thickness (value in parenthesis) = 3/8 inch.

<sup>4</sup>Insulation thickness (value in parenthesis) = 1 inch.

<sup>5</sup>Insulation thickness (value in parenthesis) = 3/4 inch.

Figure 39: Typical Arrangement of Refrigerant Pipe and Cable(s) in a Utility Conduit.

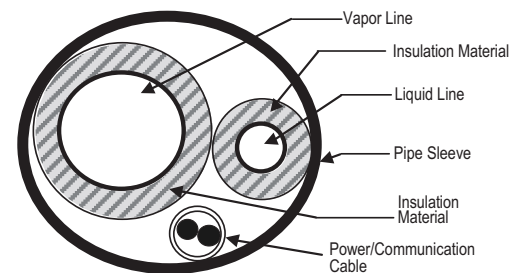

### Note:

Provide expansion joints in long pipe segments and place in an accessible conduit box for inspection. Use galvanized curved sheet metal saddles at all mounting points. Pipe must be allowed to move freely linearly.

## Flaring and Brazing Procedures

One of the main causes of refrigerant leaks is a defective connection. For LG HVAC systems, the installer needs to know how perform both flared and brazed connections successfully.

### Note:

- During installation, it is imperative to keep the piping system free of contaminants and debris such as copper burrs, slag, or carbon dust.
- ⚠ Do not use kinked pipe caused by excessive bending in one specific area on its length.

## Flaring Procedure

### Note:

When selecting flare fittings, always use a 45° fitting rated for use with high pressure refrigerant R410A. Selected fittings must also comply with local, state, or federal standards.

#### 1. Cut the pipe to length.

- Measure the distance between the indoor unit and the outdoor unit.
- Cut the pipes a little longer than measured distance.

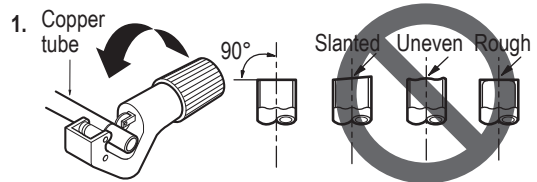

#### 2A. Remove the burrs.

- Completely remove all burrs from pipe ends.
- When removing burrs, point the end of the copper pipe down to avoid introducing foreign materials in the pipe.

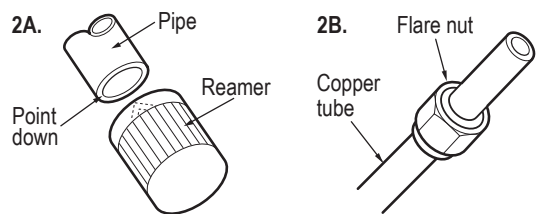

#### 2B. Slide the flare nut onto the copper tube.

#### 3. Flaring the pipe end.

- Use the proper size flaring tool to finish flared connections as shown.
- ALWAYS create a 45° flare when working with R410A.

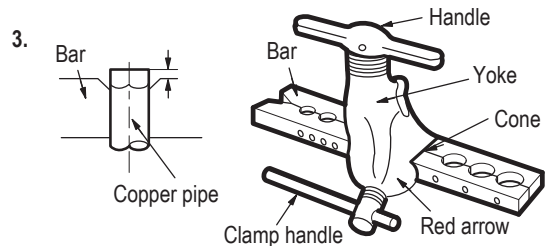

#### 4. Carefully inspect the flared pipe end.

- Compare the geometry with the figure to the right
- If the flare is defective, cut it off and re-do procedure.
- If flare looks good, blow the pipe clean with dry nitrogen.

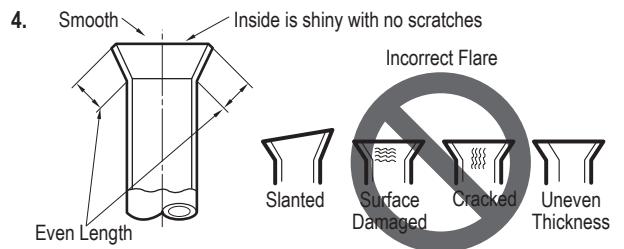

Dimensions of the Flare.

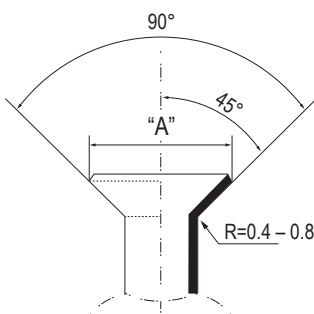

Flared Connection Dimensions / Tightening Torque.

Pipe Size (in. O.D.)	Outside Diameter (mm)	"A" Dimension (mm [in.])
1/4	6.35	~ 9.1 (11/32 - 23/64)
3/8	9.52	~ 13.2 (1/2 - 33/64)
1/2	12.7	~ 16.6 (41/64 - 21/32)
5/8	15.88	~ 19.7 (49/64 - 25/32)
3/4	19.05	-

## Tightening the Flare Nuts

Tightening Torque for Flare Nuts.

Pipe Size (in. O.D.)	Outside Diameter (mm)	Tightening Torque (ft-lbs.)
1/4	6.35	13.0 - 18.0
3/8	9.52	24.6 - 30.4
1/2	12.7	39.8 - 47.7
5/8	15.88	45.4 - 59.3
3/4	19.05	71.5 - 87.5

- When connecting the flare nuts, coat the flare (outside only) with polyvinyl ether (PVE) refrigeration oil only.

### Note:

- ⊘ Do not use polyolyester (POE) or any other type of mineral oil as a thread lubricant. These lubricants are not compatible with the PVE oil used in this system and create oil sludge leading to equipment damage and system malfunction.
  - ⊘ Do not add any contaminants inside the refrigerant piping.
- Initially hand tighten the flare nuts using three (3) or four (4) turns.
  - To finish tightening the flare nuts, use both a torque wrench and a backup wrench.
  - After all the piping has been connected and the caps have been tightened, check for refrigerant gas leaks.

## Loosening the Flare Nuts

Always use two (2) wrenches to loosen the flare nuts.

## Brazing Procedure

### ⚠ WARNING

⊘ Do not braze in an enclosed location. ⊘ Do not allow the refrigerant to leak during brazing. Always test for gas leaks before and after brazing. If the refrigerant combusts, it generates a toxic gas that will cause physical injury or death.

### Note:

Braze the pipes to the service valve pipe stub of the outdoor unit.

- All joints are brazed in the field. LG HVAC refrigeration system components contain very small capillary tubes, small orifices, electronic expansion valves, oil separators, and heat exchangers that can easily become blocked. Proper system operation depends on the installer using best practices and utmost care while assembling the piping system.
- Store pipe stock in a dry place; keep stored pipe capped and clean.
- Blow clean all pipe sections with dry nitrogen prior to assembly.
- Use adapters to assemble different sizes of pipe.
- Always use a non-oxidizing material for brazing. ⊘ Do not use flux, soft solder, or anti-oxidant agents. If the proper material is not used, oxidized film will accumulate and clog or damage the compressors. Flux can harm the copper piping or refrigerant oil.
- Use a tubing cutter, ⊘ do not use a saw to cut pipe. De-bur and clean all cuts before assembly.
- Brazing joints:
  - Use a dry nitrogen purge operating at a minimum pressure of three (3) psig and maintain a steady flow.
  - Use a 15% silver phosphorous copper brazing alloy to avoid overheating and produce good flow.
  - Protect isolation valves, electronic expansion valves, and other heat-sensitive control components from excessive heat with a wet rag or heat barrier spray.

Figure 40: Refrigerant Pipe Brazing.

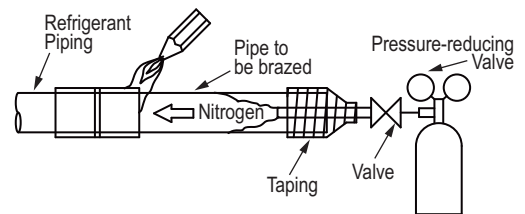

# INSTALLING MULTI F WITH LGRED SYSTEMS

## Multi F with LGRED Outdoor Unit to Indoor Unit Piping Connections

### Note:

#### ⊘ Avoid Pipe Damage

- When routing field-provided piping, ⊘ avoid damaging the outdoor unit from excessive vibration.
- Properly insulate the liquid and gas lines separately up to the point of connection at the unit frame.
- See table below for Multi F with LGRED outdoor unit connection types.

- ⊘ Correctly route the piping so it does not make contact with mounting bolts. Allow room for field installation.

Table 21: Multi F with LGRED Outdoor Unit Piping Connections.

Outdoor Unit Piping Connections	LMU180HHV	LMU240HHV	LMU300HHV
Liquid Line Connection (in., OD) x Qty.	Ø1/4 x 2	Ø1/4 x 3	Ø1/4 x 4
Vapor Line Connection (in., OD) x Qty.	Ø3/8 x 2	Ø3/8 x 3	Ø3/8 x 4

Figure 41: Multi F with LGRED Outdoor Unit Refrigerant Pipe Connections (LMU240HHV shown as example).

Multi F with LGRED Outdoor Unit (18, 24, 30kBtu/h)

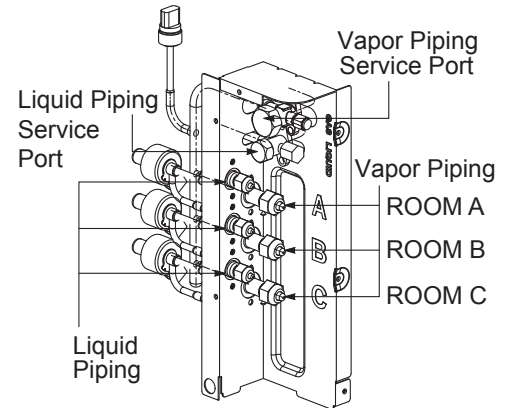

Table 22: Indoor Unit Pipe Sizes.

Indoor Unit Capacity	Vapor Line Piping Size (in., OD)	Liquid Line Piping Size (in., OD)
7,000 Btu/h	Ø3/8	Ø1/4
9,000 Btu/h		
12,000 Btu/h		
15,000 Btu/h		
15,000 Btu/h: Console; 18,000 Btu/h	Ø1/2	Ø1/4
24,000 Btu/h		

Table 24: Indoor Unit Piping Connections.

Indoor Unit Capacity	Vapor Line Conn. (in., OD)	Liquid Line Conn. (in., OD)
7,000 Btu/h	Ø3/8	Ø1/4
9,000 Btu/h		
12,000 Btu/h		
15,000 Btu/h		
18,000 Btu/h: Wall-Mounted	Ø5/8	Ø3/8
15,000 Btu/h: Console; 18,000 Btu/h: Low Static Duct, Four-Way Cassette, VAHU	Ø1/2	Ø1/4
24,000 Btu/h	Ø1/2	Ø1/4

### Note:

Connection sockets (included as a factory-supplied accessory with the indoor units) will need to be used when piping the indoor units to the outdoor unit. See tables above and below for indoor unit piping connection and connection socket dimensions. See the following page for the connection socket installation procedure.

Table 23: Connection Socket Dimensions.

Indoor Unit Capacity	Vapor (in., OD)		Liquid (in., OD)	
	A	B	A	B
18,000 Btu/h Wall-Mounted and Vertical Air Handling Units	Ø3/8 → Ø1/2, Ø1/2 → Ø5/8		Ø1/4 → Ø3/8	
15,000 Btu/h: Console; 18,000 Btu/h: Low Static Duct, Four-Way Cassette, VAHU	Ø3/8 → Ø1/2		N/A	
24,000 Btu/h	Ø3/8 → Ø1/2		N/A	

## Installing Field Piping to the Outdoor Unit Piping Connections

1. Verify the outdoor unit service ports are closed.
2. Remove the caps on the outdoor unit piping connections.
3. Connect the gas piping first to ROOM A, then to ROOM B, then to ROOM C, in that order. Number of connections will differ depending on outdoor unit.
4. Tighten each gas piping connection individually following the "Tightening the Flare Nuts" procedure below.
5. Connect the liquid piping first to ROOM A, then to ROOM B, then to ROOM C, in that order. Number of connections will differ depending on outdoor unit.
6. Tighten each liquid piping connection individually following the "Tightening the Flare Nuts" procedure below.

Figure 42: Close Up of the Field Piping to the Outdoor Unit Piping Connection.

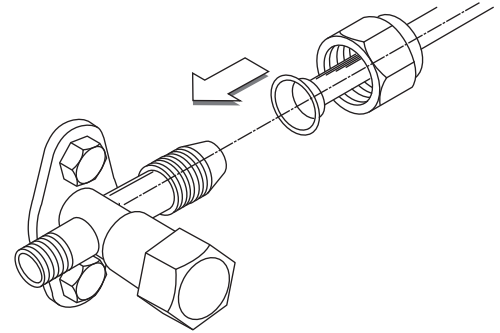

## Tightening the Flare Nuts

Tightening Torque for Flare Nuts.

Pipe Size (in. O.D.)	Outside Diameter (mm)	Tightening Torque (ft.-lbs.)
1/4	6.35	13.0 - 18.0
3/8	9.52	24.6 - 30.4
1/2	12.7	39.8 - 47.7
5/8	15.88	45.4 - 59.3
3/4	19.05	71.5 - 87.5

1. When connecting the flare nuts, coat the flare (outside only) with polyvinyl ether (PVE) refrigeration oil only.

## Note:

- ⊘ Do not use polyolyster (POE) or any other type of mineral oil as a thread lubricant. These lubricants are not compatible with the PVE oil used in this system and create oil sludge leading to equipment damage and system malfunction.
- ⊘ Do not add any contaminants inside the refrigerant piping.

2. Initially hand tighten the flare nuts using three (3) or four (4) turns.
3. To finish tightening the flare nuts, use both a torque wrench and a backup wrench.
4. After all the piping has been connected and the caps have been tightened, check for refrigerant gas leaks.

## Using the Connection Socket

Some indoor units require the use of a connection socket when piping the indoor units to the outdoor unit. (See previous page for information.) The connection sockets are included as a factory-supplied accessory with the indoor units. To install:

1. Align the center of the piping sections as seen in the diagrams at right and below.
2. Follow the "Tightening the Flare Nuts" procedure above.

Figure 43: Connection Socket Installation.

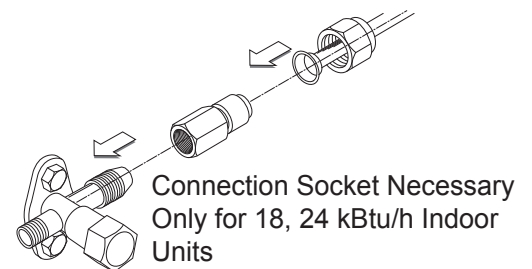

Figure 44: Connection Socket Diagram, External View.

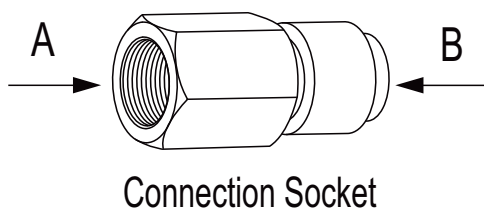
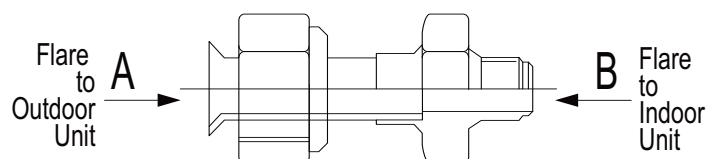

Figure 45: Connection Socket Diagram, Internal View.



# INSTALLING MULTI F MAX WITH LGRED SYSTEMS

MULTI F WITH LGRED<sup>®</sup>  
MULTI F MAX

## Multi F MAX with LGRED Refrigerant Piping Connections / Piping Routes

For Multi F MAX with LGRED outdoor units, piping can be installed in one of four directions: front, rear, right, and bottom. Whatever direction is chosen, plug the access holes with field-provided putty or insulation to fill all gaps.

If the piping is installed from the bottom, the access hole of the base pan must be knocked out before piping work begins.

Figure 46: Multi F MAX with LGRED Outdoor Unit Refrigerant Piping Connection Options.

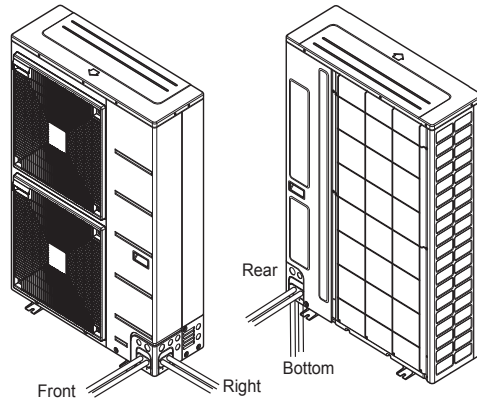

Figure 47: Removing the Base Pan Knock Out Hole.

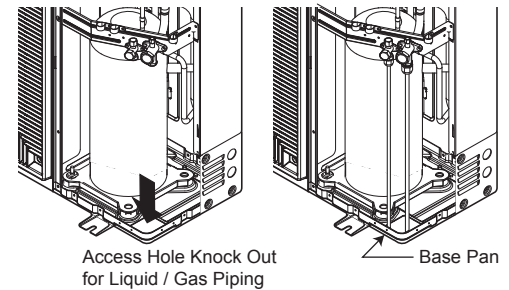
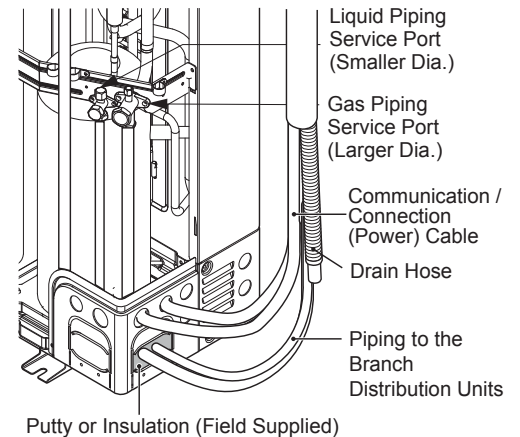

Figure 48: Filling Access Holes in the Outdoor Units.



### ⚠ WARNING

Insects or small animals entering the outdoor unit will cause a short circuit in the electrical box, which will lead to fire, electric shock, physical injury, or death.

### Note:

Insects or small animals entering the outdoor unit will cause a short circuit in the electrical box, which will lead to unit failure.

## Multi F MAX with LGRED Outdoor Unit System Piping Connections

### Note:

#### ⊘ Avoid Pipe Damage

- When routing field-provided piping, ⊘ avoid damaging the outdoor unit from excessive vibration.
- Properly insulate the liquid and gas lines separately up to the point of connection at the unit frame.
- See table below for Multi F MAX outdoor unit connection types.

- ⊘ Correctly route the piping so it does not make contact with mounting bolts. Allow room for field installation.

Table 25: Multi F MAX with LGRED Outdoor Unit Piping Connections.

Outdoor Unit Piping Connections	LMU361HHV, LMU421HHV, LMU480HHV
Liquid Line Connection (in., OD) x Qty.	Ø3/8 x 1
Vapor Line Connection (in., OD) x Qty.	Ø3/4 x 1

Figure 49: Multi F MAX with LGRED Outdoor Unit Refrigerant Pipe Connections.

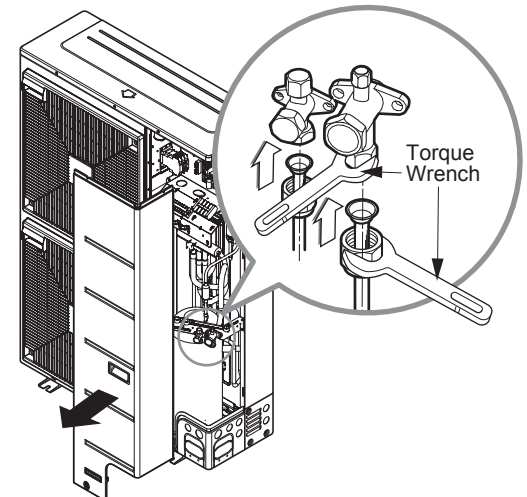

## Branch Distribution to Indoor Unit Piping Connections

- Install indoor unit liquid and vapor refrigerant pipes (and connection wiring) to the appropriate branch distribution ports.
- Clearly note on the indoor unit's refrigerant piping (liquid, vapor) which branch distribution port it is connected to (A, B, C, D).

Table 26: Branch Distribution Unit Piping Connections.

Branch Distribution Unit	Refrigerant Connections Pipe Size (in.)		Connectible Indoor Unit Capacity (Btu/h)
	Liquid	Vapor	
PMBD3620	Ø1/4 x 2	Ø3/8 x 2	7,000, 9,000, 12,000, 15,000, 18,000, 24,000
PMBD3630	Ø1/4 x 3	Ø3/8 x 3	7,000, 9,000, 12,000, 15,000, 18,000, 24,000
PMBD3640	Ø1/4 x 4	Ø3/8 x 4	7,000, 9,000, 12,000, 15,000, 18,000, 24,000
PMBD3641	Ø1/4 x 4	Ø3/8 x 3	7,000, 9,000, 12,000, 15,000, 18,000, 24,000 (A, B, C)
		Ø1/2 x 1	24,000, 36,000 (D)

Figure 51: Branch Distribution Ports to Indoor Units -- Side View.

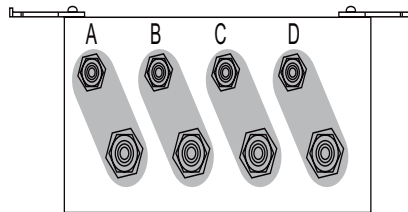
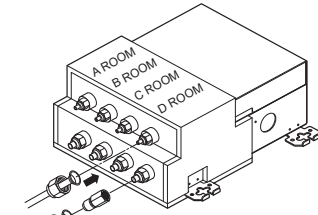

Figure 50: Branch Distribution Piping Connections.

Multi F MAX with LGRED Outdoor Units (36, 42, 48 kBtu/h)

(Branch Distribution Unit: PMBD3640)



(For 7~24 kBtu/h Indoor Units)

(Branch Distribution Unit: PMBD3641)

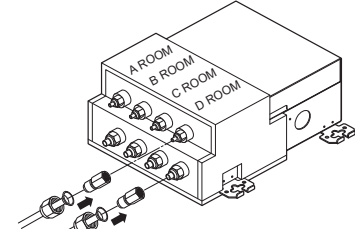

(Ports A~C only for 7~24 kBtu/h Indoor Units;  
Port D only for 24 or 36 kBtu/h Indoor Units)

Table 27: Indoor Unit Pipe Sizes.

Indoor Unit Capacity	Vapor Line Pipe Size (in., OD)	Liquid Line Piping Size (in., OD)
7,000 Btu/h	Ø3/8	Ø1/4
9,000 Btu/h		
12,000 Btu/h		
15,000 Btu/h		
15,000 Btu/h: Console; 18,000 Btu/h	Ø1/2	Ø3/8
24,000 Btu/h		
36,000 Btu/h	Ø5/8	Ø3/8

Table 28: Indoor Unit Piping Connections.

Indoor Unit Capacity	Vapor Line Conn. (in., OD)	Liquid Line Conn. (in., OD)
7,000 Btu/h	Ø3/8	Ø1/4
9,000 Btu/h		
12,000 Btu/h		
15,000 Btu/h		
18,000 Btu/h: Wall-Mounted	Ø5/8	Ø3/8
15,000 Btu/h: Console; 18,000 Btu/h: Low Static Duct, Four-Way Cassette, VAHU	Ø1/2	Ø1/4
24,000 Btu/h		
36,000 Btu/h		
36,000 Btu/h	Ø5/8	Ø3/8

### Note:

Connection sockets (included as a factory-supplied accessory with the indoor units) will need to be used when piping the indoor units to the branch distribution unit. The connection sockets for 36k indoor units are factory supplied with the branch distribution units. See tables above and below for indoor unit piping connection and connection socket dimensions. See the following page for the connection socket installation procedure.

Table 29: Connection Socket Dimensions.

Indoor Unit Capacity	Vapor (in., OD)		Liquid (in., OD)	
	A	B	A	B
18,000 Btu/h: Wall-Mounted	Ø3/8 → Ø1/2, Ø1/2 → Ø5/8		Ø1/4 → Ø3/8	
15,000 Btu/h: Console; 18,000 Btu/h: Low Static Duct, Four-Way Cassette, VAHU	Ø3/8 → Ø1/2		N/A	
24,000 Btu/h*	Ø3/8 → Ø1/2		N/A	
36,000 Btu/h	Ø1/2 → Ø5/8		Ø1/4 → Ø3/8	

\*No socket adapter is required if connected to Port D on the PMBD3641.

# INSTALLING MULTI F MAX WITH LGRED SYSTEMS

MULTI F WITH LGRED<sup>®</sup>  
MULTI F MAX

## Installing Field Piping to the Branch Distribution Unit Piping Connections

1. Remove any caps, etc., that could be on the branch distribution unit.
2. Tighten each piping connection individually following the "Tightening the Flare Nuts" procedure below.
3. When all piping installation has been completed, perform the triple leak / pressure and evacuation tests (see the Final Installation Procedures Section), verify that the system does not have any leaks, and then fully insulate all joints / connections.

## Using the Connection Socket

Some indoor units require the use of a connection socket when piping the indoor units to the branch distribution unit. (See previous page and below for information.) The connection sockets are included as a factory-supplied accessory with the indoor units, or in the case of the 36k indoor unit, it is factory supplied with the branch distribution units. To install:

1. Remove any caps, etc., that could be on the branch distribution unit.
2. Align the center of the piping sections as seen in the diagram at right.
3. Tighten each piping connection individually following the "Tightening the Flare Nuts" procedure below.
4. When all piping installation has been completed, perform the triple leak / pressure and evacuation tests (see the Final Installation Procedures Section), verify that the system does not have any leaks, and then fully insulate all joints / connections.

Figure 53: Connection Socket Diagram, External View.

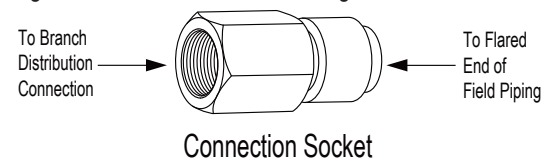
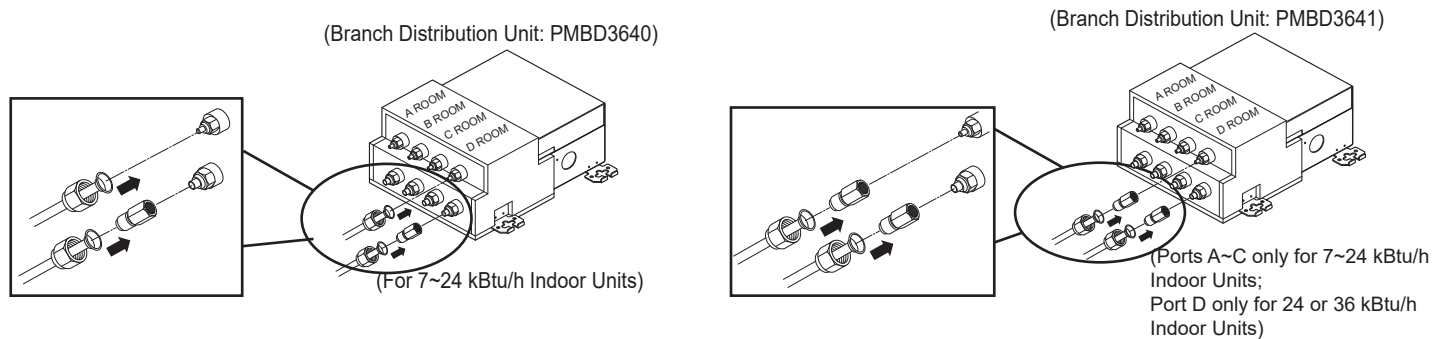

Figure 52: Close Up of Branch Distribution to Indoor Unit Piping Connections.



## Tightening the Flare Nuts

Tightening Torque for Flare Nuts.

Pipe Size (in. O.D.)	Outside Diameter (mm)	Tightening Torque (ft.-lbs.)
1/4	6.35	13.0 - 18.0
3/8	9.52	24.6 - 30.4
1/2	12.7	39.8 - 47.7
5/8	15.88	45.4 - 59.3
3/4	19.05	71.5 - 87.5

1. When connecting the flare nuts, coat the flare (outside only) with polyvinyl ether (PVE) refrigeration oil only.

## Note:

- ⊘ Do not use polyolyester (POE) or any other type of mineral oil as a thread lubricant. These lubricants are not compatible with the PVE oil used in this system and create oil sludge leading to equipment damage and system malfunction.
- ⊘ Do not add any contaminants inside the refrigerant piping.

2. Initially hand tighten the flare nuts using three (3) or four (4) turns.
3. To finish tightening the flare nuts, use both a torque wrench and a backup wrench.
4. After all the piping has been connected and the caps have been tightened, check for refrigerant gas leaks.

Figure 54: Socket Connection.

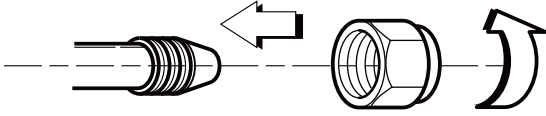
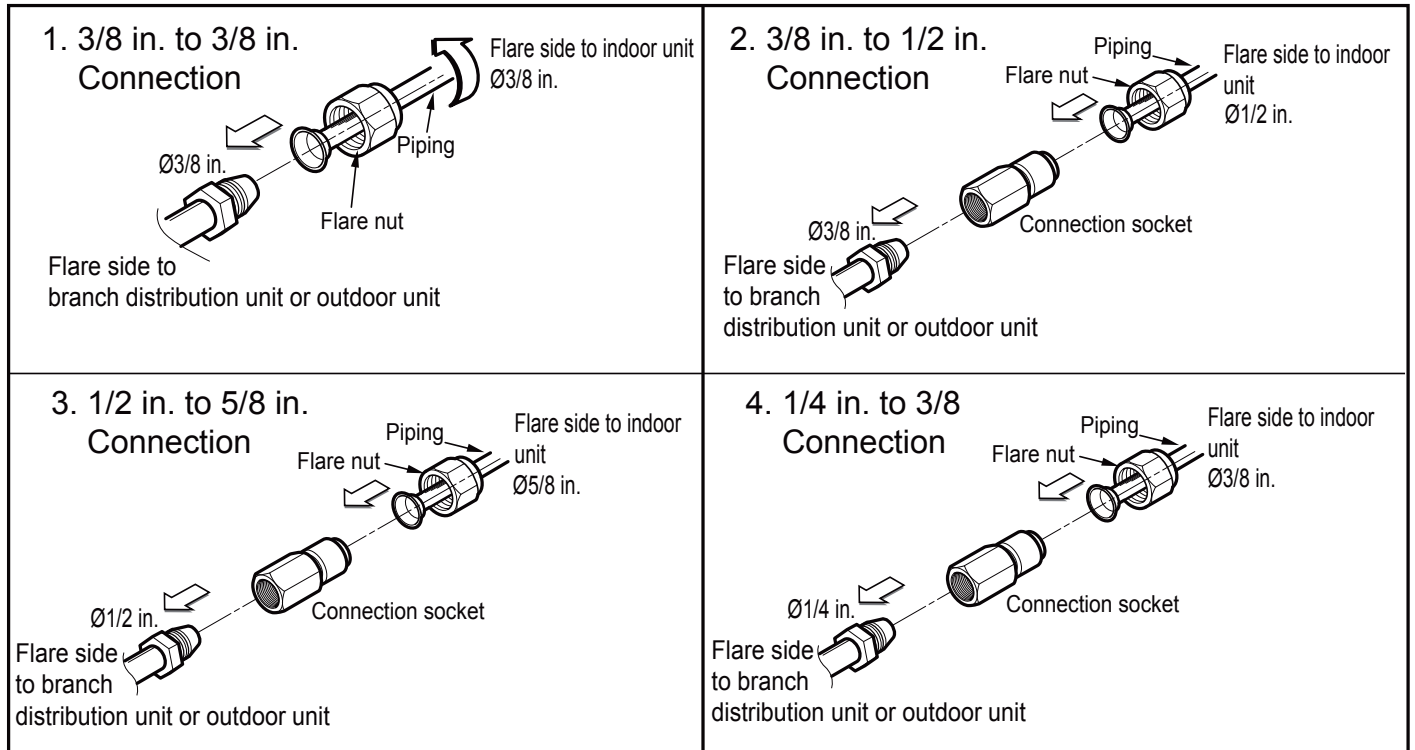

Figure 55: Possible Outdoor Unit or Branch Distribution Unit to Indoor Unit Connections.



# INSTALLING MULTI F MAX WITH LGRED SYSTEMS

MULTI F WITH LGRED<sup>®</sup>  
MULTI F MAX

MULTI F / MULTI F MAX with LGRED Outdoor Unit Installation Manual

## Multi F MAX with LGRED Y-Branch Kit PMBL5620

The LG-supplied Y-Branch kit PMBL5620 MUST be used when installing two (2) branch distribution units in parallel on one (1) Multi F MAX with LGRED system. ⚠ Field-supplied fittings are not permitted. Each Y-Branch kit includes two (2) Y-branches (one for the liquid line and one for the vapor line) and insulation covers.

Y-branches can be installed in horizontal or vertical configurations. When installed vertically, position the Y-branch so the straight through leg is  $\pm 3^\circ$  of plumb. When installed horizontally, position the Y-branch so the take-off leg is level and shares the same horizontal plane as the straight-through leg  $\pm 5^\circ$  rotation.

Y-branches must be properly installed following instructions in the applicable LG manual. Y-branches must always be installed with the single port facing the outdoor unit and the two-port end facing the branch distribution units. ⚠ Do not install Y-branches backwards as refrigerant flow cannot make U-turns. The Y-branch kit must be located at least three (3) feet from the outdoor unit. Provide a minimum of 20 inches between a Y-branch and the branch distribution unit.

When a Y-branch is located in a pipe chase or other concealed space, access doors must be provided for inspection access.

The equivalent pipe length of each Y-branch (1.6') must be added to the main pipe segment entered into LATS piping design software.

### Note:

- Design pressure is 551 psig.
- All dimensions in inches. Tolerance  $\pm 1/4$  inch.
- Images are not to scale.

Figure 58: Horizontal Configuration End View.

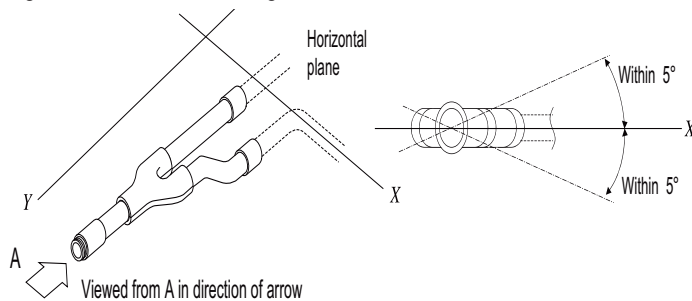

Figure 56: Y-Branch Port Identifier Diagram.

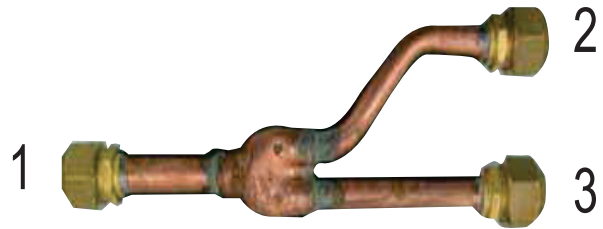
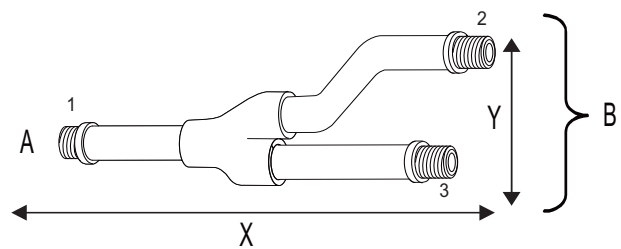

Figure 57: Y-Branch Dimensions Diagram.



A = To Outdoor Unit

B = To Branch Distribution Unit

Table 30: Multi F MAX with LGRED Y-Branch Specifications.

Model	Y-Branch Type	Port Identifier (inch)		
		1	2	3
PMBL5620	Liquid	$\text{\O}3/8$	$\text{\O}3/8$	$\text{\O}3/8$
	Vapor	$\text{\O}3/4$	$\text{\O}3/4$	$\text{\O}3/4$
	Y-Branch Type	Dimensions (inch)		
		X	Y	
	Liquid	13.80	3.24	
	Vapor	12.48	3.02	

Figure 59: Y-branch Installation Alignment Specification.

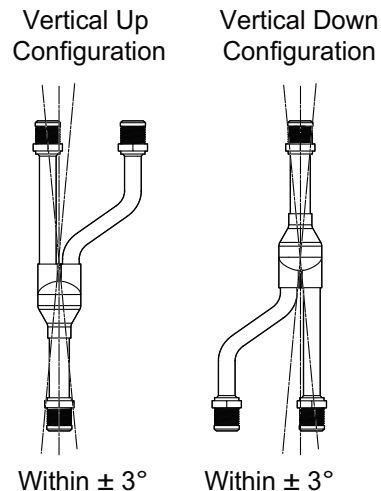

## Bundling

If a conduit or piping set cover is not used on the connection from the outdoor unit to the interior, bundle both insulated refrigerant pipes, the drain hose, and outdoor unit to indoor unit / branch distribution unit communication / connection (power) cable together with wide vinyl tape.

1. Piping must be fully encased in insulation material: Overlap the field installation piping insulation material and the indoor unit piping insulation material.
2. Bind together the two pipes, using vinyl tape. Make sure there are no gaps during the binding.
3. Be sure the cutting line is placed upward.
4. Wrap the rear piping section with narrow vinyl tape.
5. Continue to wrap the indoor unit pipe as connected to the outdoor connection pipe.
6. Using a wider vinyl tape, bundle the piping and drain hose together.
  - Tape must be sufficient to cover the piping in order to fit into the rear piping housing area at the back of the indoor unit.

## Special Applications

If an additional drain hose is necessary, the end of drain outlet must be routed above the ground. Secure the drain hose appropriately.

### When the Outdoor Unit is Installed Below the Indoor Unit:

1. Use a conduit, piping set cover, or bundle the (separately) insulated refrigerant piping, the drain hose, and the communications / connection (power) cable together.
2. Make sure to include some slack in the wiring. Wiring must be installed in an upwards direction to prevent water from accessing into the control box.
3. Secure the conduit, piping set cover, or bundle along the outside wall using saddles or a similar type of piping support.
4. Seal any openings in the wall that are around the piping.

### When the Outdoor Unit is Installed Above the Indoor Unit:

1. Use a conduit, piping set cover, or bundle the (separately) insulated refrigerant piping and the communications / connection (power) cable together up to the outdoor unit service valves.
2. Make sure to include some slack in the wiring. Wiring must be installed in upwards direction to prevent water from traveling into the control box.
3. If necessary, secure the conduit, piping set cover, or bundle along the outside wall using saddles or a similar type of piping support.
4. Ensure the insulated drain hose from the indoor unit is installed away from the outdoor unit, and in a downwards direction. If necessary, secure along the outside wall using saddles or a similar type of support.
5. Seal any openings in the wall that are around the piping.

Figure 60: Bundling the Connection Components (From Outdoor Unit to Indoor Unit / Branch Distribution Unit [Multi F MAX with LGRED systems only]).

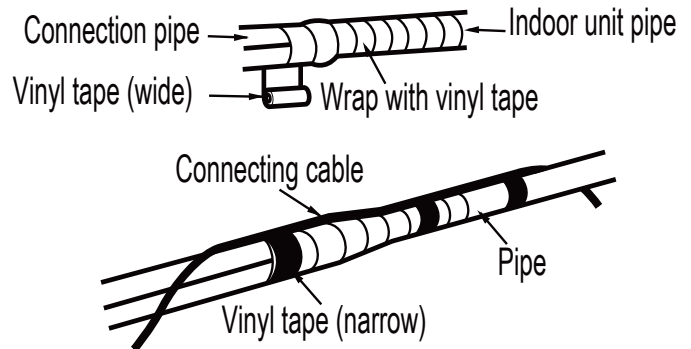
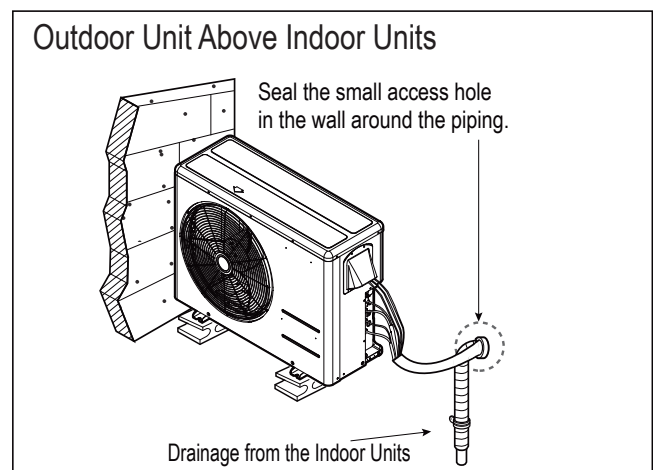
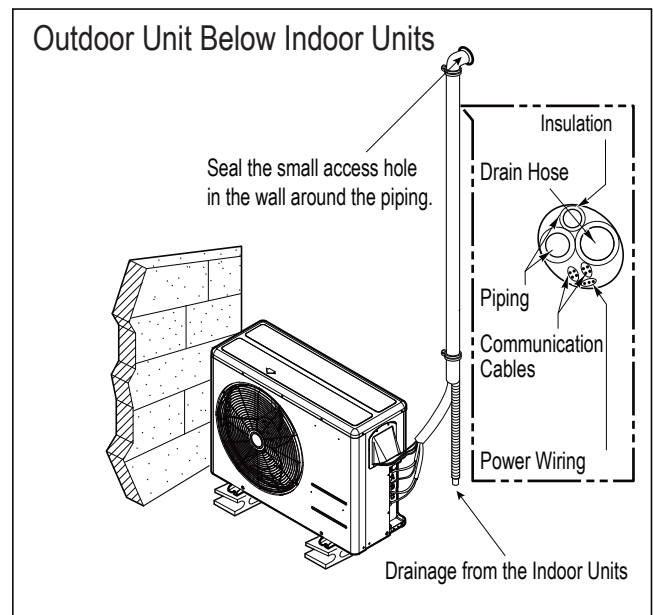

Figure 61: Special Applications.



---

---

## Condensate Drain Piping

Outdoor unit requires condensate drain piping. Condensate drain pipe must be constructed with materials approved by local code. See pages 20 to 22 for information in reference to outdoor unit placement and condensate drainage.

### Drain Leak Test

A leak test must be performed 24 hours after the drainage system has been installed.

### **Note:**

*For indoor unit condensate drain piping information, see the Multi F / Multi F MAX Indoor Unit Engineering Manual, or the installation manual specific to the indoor unit type.*

**Note:**

For information regarding insulation for underground or penetration situations, see the “General Refrigerant Piping System Information” section.

**General Piping System Insulation**

All refrigerant piping from the outdoor unit to the indoor units / branch distribution units (Multi F MAX with LGRED systems only) must be insulated correctly for safety and usage. Y-branch connections, refrigerant piping, field-provided isolation ball valves (if present), service valves, and elbows must be properly and completely insulated using closed cell pipe insulation (up to the indoor unit piping connections). To prevent heat loss / heat gain through the refrigerant piping, all refrigerant piping including liquid lines and vapor lines must be insulated separately. Insulation must be a minimum 1/2 inches thick, and thickness will need to be increased based on ambient conditions and local codes. Table on the next page lists minimum wall thickness requirements for Ethylene Propylene Diene Methylene (EPDM) insulation.

Inside the outdoor unit, maximum pipe temperature is 248°F and minimum pipe temperature is -40°F. For field insulation of refrigerant piping between outdoor units and indoor units, consider the following pipe temperature ranges for an operating heat pump system:

- Heating mode refrigerant temperature ranges: Liquid, 75-118°F; High Pressure Vapor, 95-220°F.
- Cooling mode refrigerant temperature ranges: Liquid, 75-118°F; Low Pressure Vapor, 40-90°F.

All insulation joints must be glued with no air gaps. Insulation material must fit snugly against the refrigeration pipe with no air space between it and the pipe. Insulation passing through pipe hangers, inside conduit, and/or sleeves must not be compressed. Protect insulation inside hangers and supports with a second layer. All pipe insulation exposed to the sun and outdoor elements must be properly protected with PVC, aluminum vapor barrier, or alternatively placed in a weather-resistant enclosure such as a pipe rack with a top cover; or meet local codes. LG-provided Y-branches are shipped from the factory with pre-formed peel-and-stick foam insulation jackets, with a 1.84 lb./ft.<sup>3</sup> density, 1/2 inch thickness, and meet UL94 MF-1 flammability.

The design engineer must perform calculations to determine if the factory-supplied insulation jackets are sufficient to meet local codes and avoid sweating. Add additional insulation if necessary. Check the fit of the insulation jacket after the Y-branch fitting and all run-out pipes are installed.

Figure 62: Typical Pipe Insulation, Power Wire and Communications Cable Arrangement

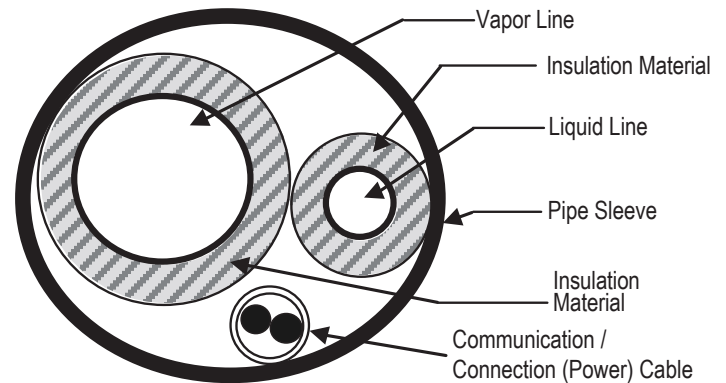

Figure 63: Typical Insulation Butt-Joint at Indoor Unit Casing.

Figure 64: Typical Refrigerant Flare Fitting Insulation Detail.

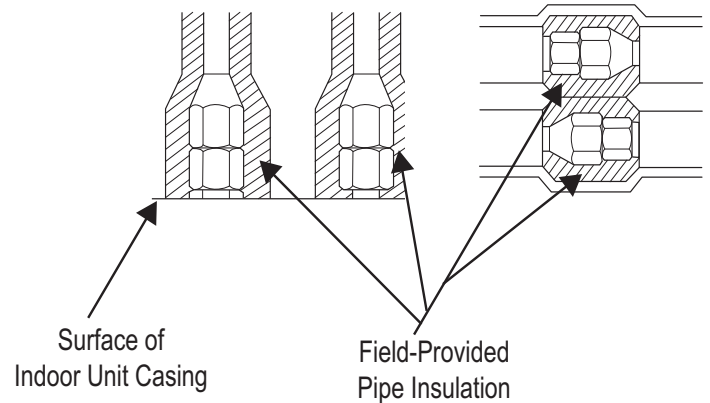
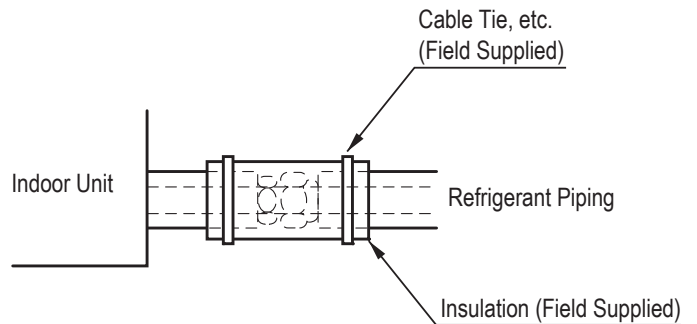

Figure 65: Insulating the Shut Off / Isolation Ball Valve (If Present).



## Minimum Refrigerant Pipe Ethylene Propylene Diene Methylene (EPDM) Insulation Wall Thickness Requirements

### Note:

- Do not insulate gas and liquid pipes together as this can result in pipe leakage and malfunction due to extreme temperature fluctuations.
- Always properly insulate the piping. Insufficient insulation will result in condensation, reduced heating/cooling performance, etc. Also, if the pipes aren't insulated properly, condensation could potentially cause damage to building finishes. Pay special attention to insulating the pipes installed in the ceiling plenum.
- Fully insulate the piping connections.
- Follow local codes and the designer's instructions when selecting ethylene propylene diene methylene (EPDM) insulation wall thickness.

Table 31: Minimum Refrigerant Pipe EPDM Insulation Wall Thickness Requirements.<sup>1</sup>

Classification		Air-conditioned location		Non-air conditioned location	
		1. Typical Conditioned Location	2. Special Conditioned Location	3. Typical Unconditioned Location	4. Special Unconditioned Location
Liquid pipe	ø1/4 inch	≥1/2 inch	≥1/2 inch	≥1/2 inch	≥1/2 inch
	ø3/8 inch				
	≥ø1/2 inch				
Vapor pipe	ø3/8 inch	≥1/2 inch	≥3/4 inch	≥3/4 inch	≥1 inch
	ø1/2 inch				
	ø5/8 inch				
	ø3/4 inch				
	ø7/8 inch				
	ø1 inch	≥3/4 inch	≥1 inch	≥1 inch	
	ø1-1/8 inches				
	ø1-1/4 inches				
	ø1-3/8 inches				
	ø1-1/2 inches				
ø1-3/4 inches					

<sup>1</sup>The thickness of the above insulation material is based on heat conductivity of 0.61 Btu/in/h/ft<sup>2</sup>/°F.

### 1. Typical Conditioned Location

A building plenum or space that contains conditioned air that does not exceed 80°F DB.

### 2. Special Conditioned Location

1. When the location is air conditioned, but there is severe temperature/humidity difference due to high ceilings.
  - Church, auditorium, theater, lobby, etc.
2. When the location is air conditioned, but internal temperature/humidity are high.
  - Bathroom, swimming pool, locker room, etc.

### 3. Typical Unconditioned Location

An unconditioned space inside a building.

### 4. Special Unconditioned Location: If conditions 1 and 2 below are present.

1. An unconditioned space or plenum of a building.
2. An area where there is an elevated humidity level.

### 5. Additional Insulation for Indoor Units Will be Required in Humid Environments.

The air conditioner factory insulation has been tested according to "ISO Conditions with Mist," and it satisfies the requirements. If the system has been operating for a long time in a high humidity environment (dew point temperature: more than 73°F), condensate is likely to form. If this happens, install 3/8 inch thick EPDM insulation that is plenum-rated with a heat-resistance factor of more than 248°F.

**Note:**

- Do not insulate gas and liquid pipes together as this can result in pipe leakage and malfunction due to extreme temperature fluctuations.
- Be sure to fully insulate the piping connections.

**Installing the Insulation**

1. Insulation material must be longer than the refrigerant piping. Each vapor and liquid piping must be insulated separately.
2. Place the closed-cell ethylene propylene diene methylene (EPDM) insulation material carefully around each refrigerant pipe so as not to damage it. Be sure the insulation material cutting line is placed upward.
3. Apply adhesive to both cut surfaces of the insulation and press together. Allow adhesive to dry so that the bond is secure and does not come apart.

**Insulating Piping Joints**

1. Push the EPDM insulation from the straight piping surrounding the joint (elbow, outdoor unit to indoor unit piping connection point, etc.) as close together as possible.
2. Cut a piece of insulation to fit the joint, overlapping the insulation on the surrounding piping by at least one (1) inch.
3. Apply adhesive to bond all the ends.
4. Secure by completely wrapping narrow vinyl tape around the insulation / joint so that there are no gaps.
5. Tape must be sufficient to cover the piping so it can fit into the rear piping housing area at the back of the indoor unit or branch distribution unit (Multi F MAX with LGRED systems only).

**Y-Branch Kit Insulation**

Each Y-branch kit comes with clam-shell type peel-and-stick insulation jackets molded to fit the Y-branch fittings—one for the liquid line, one for the vapor line.

- Check the fit of the Y-branch clam-shell insulation jacket after the Y-branch is installed.
- Mark all the pipes at the points where the insulation jacket ends.
- Remove the jacket.
- Install field-provided insulation on the run-out and main pipes first.
- Peel the adhesive glue protector slip from the insulation jacket, and install the clam-shell jacket over the fitting.

Figure 68: Y-branch Insulation Detail.

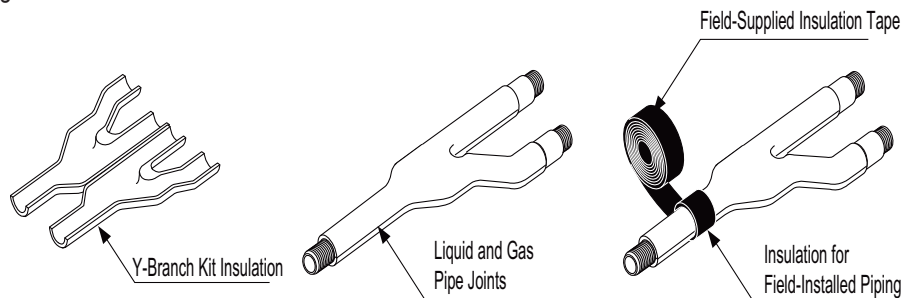

**Note:**

**Additional Insulation for Y-Branched Will be Required in Humid Environments.**

If the system has been operating for a long time in a high humidity environment (dew point temperature: more than 73°F), condensate is likely to form. If this happens, install 3/8 inch thick ethylene propylene diene methylene (EPDM) insulation that is plenum-rated with a heat-resistance factor that follows applicable local, state, and federal codes.

Figure 66: Correct Cutting Line Placement.

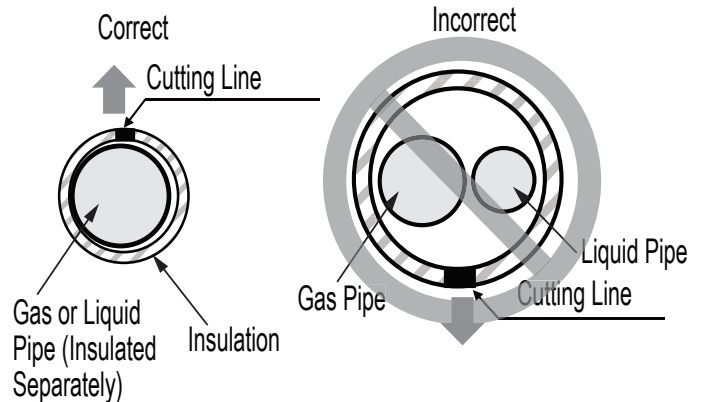
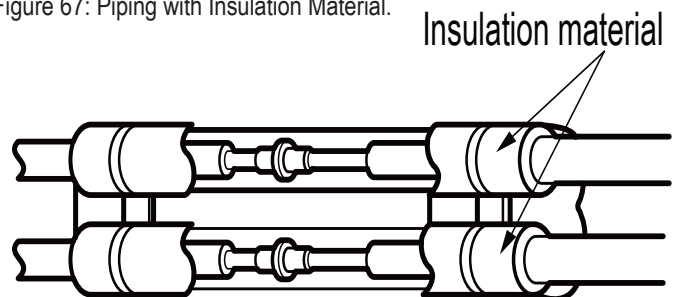

Figure 67: Piping with Insulation Material.



### ⚠ WARNING

- All power (line voltage) wiring and communication cable installation must be performed by trained service providers working in accordance with all local, state, and National Electrical Code (NEC) / UL / ETL federal regulations related to electrical equipment and wiring, and following the manufacturer product diagrams, requirements, and instructions in this manual. Electric shock can cause physical injury or death.
- Be sure that main power to the unit is completely off before proceeding. Follow all safety and warning information outlined at the beginning of this manual. Failure to do so will cause electric shock and bodily injury.
- Install a main shutoff switch or circuit breaker that interrupts all power sources simultaneously (circuit breaker must be resistant to electromagnetic currents). Be sure that the circuit breaker or some other emergency power cutoff device is in place before any power wiring is done to the system. Failure to do so will cause bodily injury or death.
- ⚡ Never touch any power lines or live cables before all power is cutoff to the system. To do so will cause bodily injury or death.
- Power wiring and communication cable sizes must comply with all applicable federal, state, and local codes. Undersized wiring will lead to unacceptable voltage at the unit and will cause a fire, which will cause bodily injury or death.
- Properly ground the outdoor unit, indoor units, and branch distribution units. Ground wiring must always be installed by a trained technician. Ground wiring is required to prevent accidental electrical shock during current leakage, which will cause bodily injury or death.
- Verify that the circuit breaker is set to OFF before installing the wiring system. Electric shock can cause physical injury or death.
- Install appropriately sized breakers / fuses / overcurrent protection switches and wiring in accordance with local, state, and NEC regulations related to electrical equipment and wiring, and following the instructions in this manual. Generated overcurrent will include some amount of direct current. Using an oversized breaker or fuse will result in electric shock, physical injury or death.
- ⚡ Do not connect ground wire to refrigerant, gas, sewage, or water piping; to lightning rods; to telephone ground wiring; or to the building plumbing system. Failure to properly provide a NEC-approved earth ground can result in electric shock, fire, physical injury or death.

### Note:

- Consider ambient conditions (temperature, direct sunlight, inclement weather, etc.) when selecting, installing, and connecting the power wiring.
- Properly ground the outdoor unit, indoor units, and branch distribution units. Ground wiring must always be installed by a trained technician. Improperly grounded wire can cause communication problems from electrical noise, and motor current leakage.
- Install appropriately sized breakers / fuses / overcurrent protection switches and wiring in accordance with local, state, and NEC regulations related to electrical equipment and wiring, and following the instructions in this manual. Generated overcurrent will include some amount of direct current. Using an oversized breaker or fuse will result in equipment malfunction and property damage.
- ⚡ Do not connect ground wire to refrigerant, gas, or water piping; to lightning rods; to telephone ground wiring; or to the building plumbing system. Failure to properly provide a NEC-approved earth ground can result in property damage and equipment malfunction.
- ⚡ Do not operate the air conditioning system until the refrigerant piping installation is complete. Operating the system before refrigerant piping is finalized will damage the compressor.

## Location / Accessing the Power Wiring and Communications Cable Connections

1. Detach the outdoor unit panel by loosening the screws.
2. Remove the control cover (if applicable) by loosening the screws.
3. Secure the wiring / cable onto the control board with the cable clamps.
4. When all connections are complete, re-attach the cover control to its original position using the screws, then re-attach the outdoor unit panel.

Figure 69: Power Wiring and Communication / Connection (Power) Cable Paths (LMU180-240-300HHV Example).

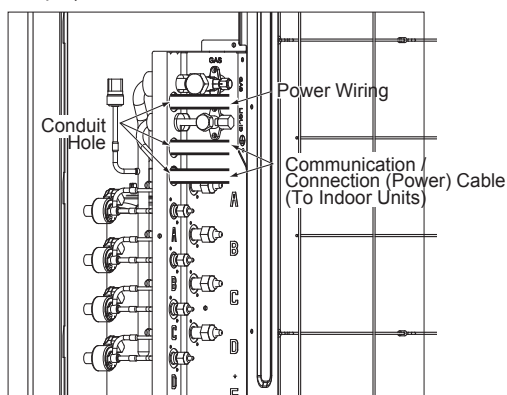
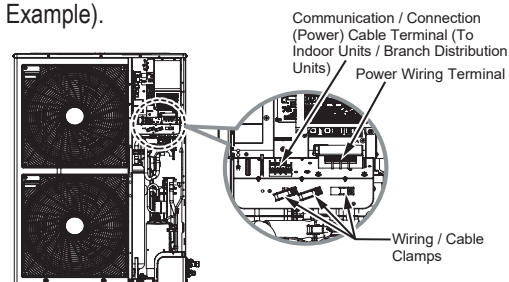

Figure 70: Location of the Power Wiring and Communication Cable Terminals (LMU361-421-480HHV Example).



## Power Wiring / Communication Cable Connections

Best practice dictates using solderless ring or fork terminals at all power wiring and communication cable terminations. Use copper bearing ring or fork terminals; ⓧ do not use galvanized or nickel plate over steel. Use appropriate crimping tool to attach the ring or fork terminals at all power wiring and control cable terminations.

### To Install a Ring or Fork Terminal:

1. Trim the wiring with wire cutters or pliers, then strip the insulation to expose the strand wiring to about 3/8 inches.
2. Using a ring terminal fastener or pliers, securely clamp a ring terminal to each stripped wire end.

### To Connect the Wiring to the Terminals:

1. Remove the JIS terminal screws from the (outdoor unit, branch distribution unit, or indoor unit) terminal plate with a JIS screwdriver. (See information about LG terminal connections on the next page.)
2. Position the ring terminal around the terminal, place the terminal screw in the ring, and tighten to the terminal plate using a JIS screwdriver.
  - Firmly attach the wire; secure in a way to prevent external forces from being imparted to the terminal block.
  - Use an appropriately sized JIS screwdriver for tightening the terminals.
  - ⓧ Do not over tighten the connections; over tightening will damage the terminals.

If ring terminals or fork terminals are not available, then:

- ⓧ Do not terminate different gauge wires to the power terminal block. (Slack in the wiring will generate heat.)
- When terminating wires of the same thickness, follow the instructions demonstrated in the figures below.

Figure 74: Proper and Improper Power Wiring Connections.

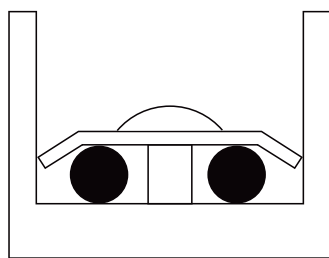

Terminate multiple power wires of the same gauge to both sides.

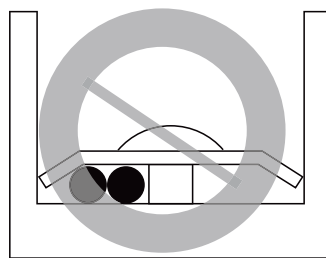

ⓧ Do not terminate two wires on one side.

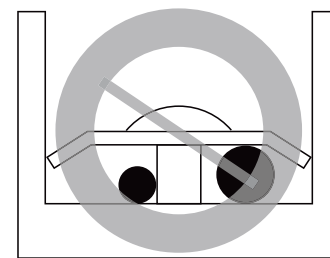

ⓧ Do not terminate different gauge wires to a terminal block.

## ⚠ WARNING

If power wires are not properly terminated and firmly attached, there is risk of fire, electric shock, and physical injury or death.

### Note:

- ⓧ Never apply line voltage power to the communications cable terminal block. If contact is made, the PCBs will be damaged.
- Always include some allowance in the wiring length when terminating. Firmly attach the wiring or cable, but provide some slack to facilitate removing the electrical panels while servicing, and to prevent external forces from damaging the terminal block.

Figure 71: Close up of a Typical Ring Terminal.

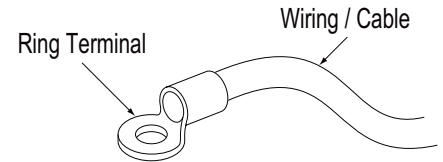

Figure 72: Adding a Ring Terminal to the Wiring.

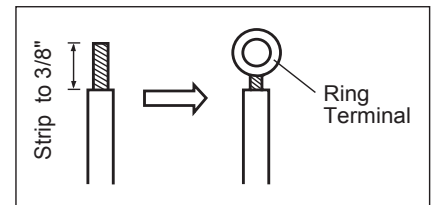
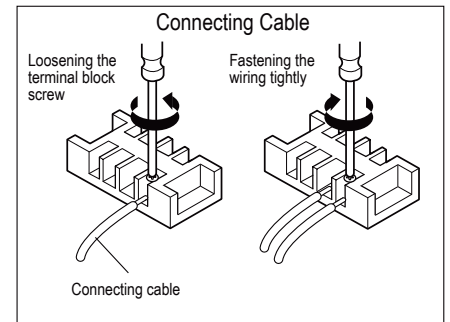

Figure 73: Tightening the Ring Terminal to the Terminal Plate.



● :Copper Wire

### LG Terminal Connections

LG uses a “JIS” type of screw for all terminals; use a JIS screwdriver to tighten and loosen these screws and avoid damaging the terminal. ⚠ Do not over tighten the connections — over tightening will damage the terminals — but firmly and securely attach the wiring in a way to prevent external forces from being imparted to the terminal block.

#### Note:

- The terminals labeled “GND” are NOT ground terminals. The terminals labeled  ARE ground terminals.
- Polarity matters. Always connect “A” to “A” and “B” to “B.”
- Always create a wiring diagram that contains the exact sequence in which all the indoor units and branch distribution units (Multi F MAX with LGRED systems only) are wired in relation to the outdoor unit.
- ⚠ Do not include splices or wire nuts in the communication cable.

Figure 75: JIS Screws.



### Power Supply / Power Wiring Specifications

- Multi F and Multi F MAX with LGRED systems operate at 1Ø, 208-230V, 60Hz, and power is wired to the outdoor unit only. The outdoor unit will supply power to the indoor units and the branch distribution units (Multi F MAX with LGRED systems only) through the communication / connection (power) cable.
- Power supply to the outdoor unit must be selected based on NEC and local codes. Maximum allowable voltage fluctuation  $\pm 10\%$  or nameplate rated value.
- Power wiring to the outdoor unit(s) must be solid or stranded, and must comply with all local and national electrical codes.
- Properly ground the outdoor unit and indoor unit per NEC and local codes.
- Ground wire must be longer than the common power / communication wires.
- Connect the wiring firmly so the wires cannot be easily pulled out.
- Refer to the inside of the chassis cover or control cover for circuit and terminal block diagrams.
- Always match color codes of each wire and follow wiring diagram.
- ⚠ Do not install power wiring to the outdoor unit and the communication / connection (power) cable to the indoor unit in the same conduit. Use separate conduits.

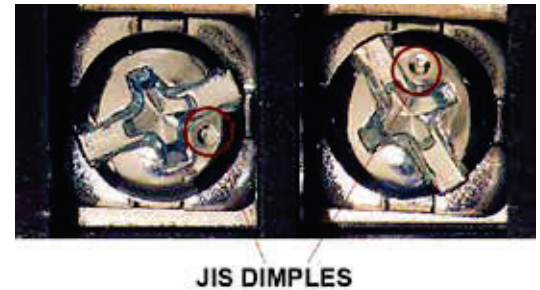
Figure 77: Multi F / Multi F MAX with LGRED Outdoor Unit Power Wiring.

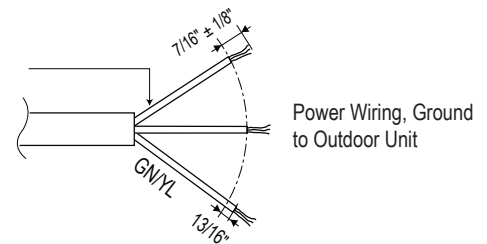
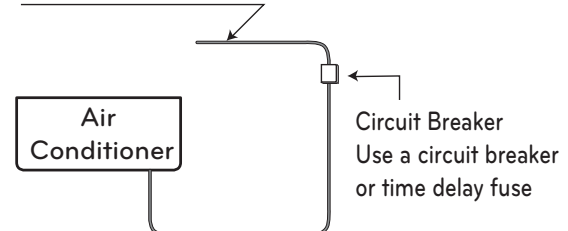

Table 32: Circuit Breaker / Fuse Size.

Outdoor Unit Model	Power Source	Maximum Overcurrent Protection	Recommended Fuse Amps
LMU180HHV	1Ø, 208-230V	30A	25A
LMU240HHV	1Ø, 208-230V	30A	25A
LMU300HHV	1Ø, 208-230V	30A	25A
LMU361HHV	1Ø, 208-230V	40A	-
LMU421HHV	1Ø, 208-230V	40A	-
LMU480HHV	1Ø, 208-230V	40A	-

Figure 76: Circuit Breaker Main Power Source



### ⚠ WARNING

- Always have a trained service provider properly ground the outdoor unit. If the outdoor unit is not properly grounded, there is a risk of electric shock, physical injury, or death.
- Provide a circuit breaker between the power source and the outdoor unit. Failure to do so will cause bodily injury or death.

## Communication / Connection (Power) Cable Specifications

- Insulation material as required by local code.
- Rated for continuous exposure of temperatures up to 140°F.
- Firmly attach the cable; provide slack but secure in a way to prevent external forces from being imparted on the terminal block.
- Wiring must be completed without splices.

### Multi F with LGRED Systems:

- Communication / connection (power) cable from the outdoor unit to the indoor unit must use a minimum of 14 AWG, four (4) conductor, stranded, shielded or unshielded (if shielded, it must be grounded to the chassis of the outdoor unit only), and must comply with applicable local and national codes.
- Use of 14 AWG, four (4) conductor, stranded, shielded or unshielded wire is allowed for lengths up to the published maximum pipe length, plus recommended slack at both ends.

### Multi F MAX with LGRED Systems:

- All communication / connection (power) cable from the outdoor unit to the branch distribution unit(s) must be a minimum of 14 AWG, four (4) conductor, stranded, shielded or unshielded (if shielded, it must be grounded to the chassis of the outdoor unit only), and must comply with applicable local and national codes.
- Communication / connection (power) cable from the branch distribution unit(s) to the indoor units must use a minimum of 14 AWG, four (4) conductor, stranded, shielded or unshielded (if shielded, it must be grounded to the chassis of the outdoor unit only), and must comply with applicable local and national codes.
- Use of 14 AWG, four (4) conductor, stranded, shielded or unshielded wire is allowed for lengths up to the published maximum pipe length, plus recommended slack at both ends.

### Note:

- Use a conduit for the communications / connection (power) cable from the outdoor unit to the indoor units and branch distribution unit(s). Electrical interference may cause product malfunction.
- ⚠ Never ground the shield of the communications cable to the indoor unit frame or other grounded entities of the building. Ground the communications cable shield only at the outdoor unit. Improperly grounding this cable can cause communications errors.
- The communications / connection (power) cable from the outdoor unit to the indoor units / branch distribution unit(s) must be separated and isolated from power wiring to the outdoor unit, computers, radio and television broadcasting facilities, as well as medical imaging equipment. Electrical interference may cause product malfunction.

Figure 78: Typical Multi F / Multi F MAX with LGRED Outdoor and Indoor / Branch Distribution Unit Wiring and Communications Cable Diagram.

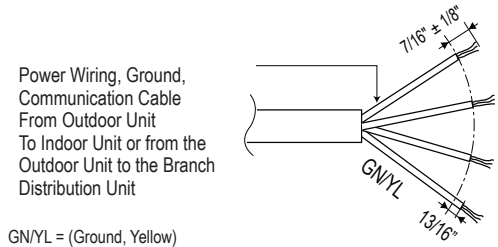

Figure 79: Typical Multi F with LGRED System General Power / Communications System Schematic.

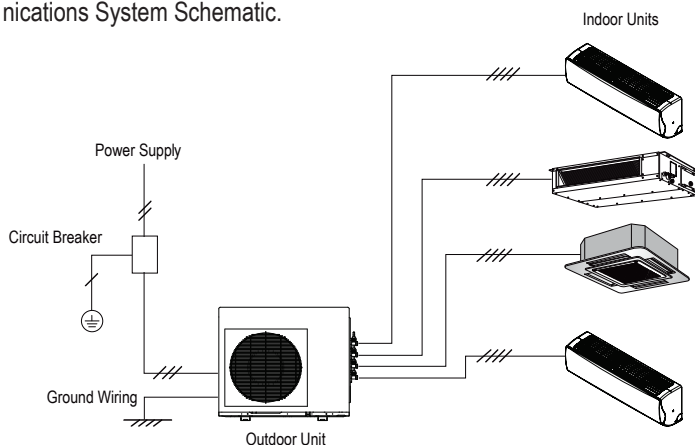

Figure 80: Typical Multi F MAX with LGRED System General Power / Communications System Schematic.

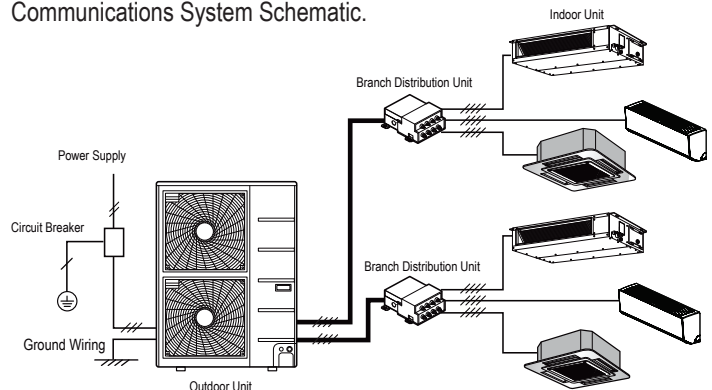
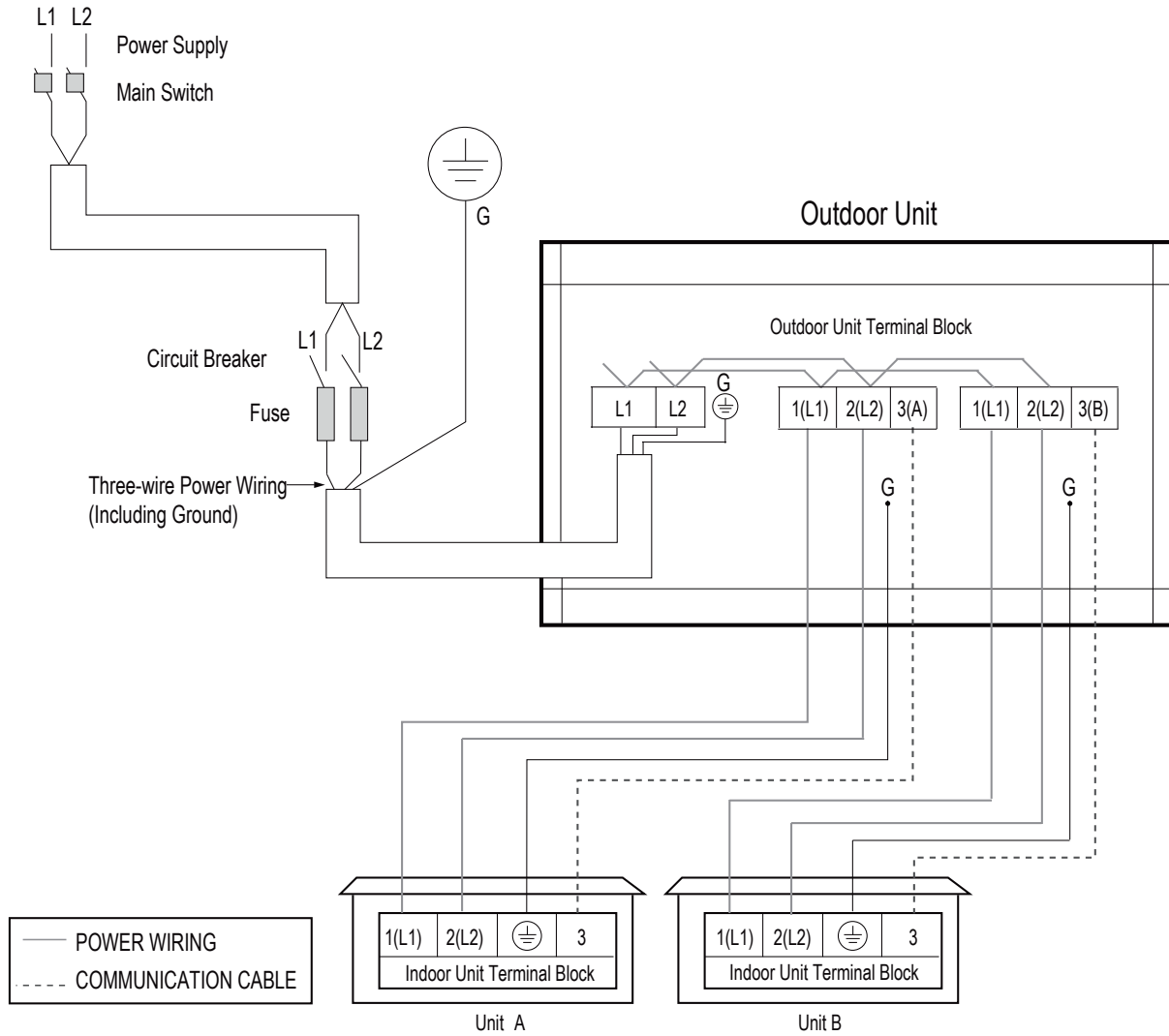

Figure 81: Multi F with LGRED LMU180HHV System Power Wiring and Communications Cable Connections.



### ⚠ WARNING

- All field-supplied wiring, components, sizes, and materials must comply with all applicable national, state, and local codes and requirements. Improper wiring will result in fire, electric shock, physical injury or death.
- Ground wiring is required to prevent accidental electrical shock during current leakage, communication problems from electrical noise, and motor current leakage. ⚡ Do not connect the ground line to the pipes. There is a risk of fire, electric shock, explosion, physical injury or death.
- Install a main shutoff switch or circuit breaker that interrupts all power sources simultaneously. There is a risk of fire, electric shock, explosion, physical injury or death.

### Note:

- All field-supplied wiring, components, sizes, and materials must comply with all applicable national, state, and local codes and requirements. Failure to install proper electrical components can result in property damage and equipment malfunction.
- Ground wiring is required to prevent communication problems from electrical noise, and motor current leakage. Failure to provide proper ground wiring can result in property damage and equipment malfunction.
- Install a main shutoff switch or circuit breaker that interrupts all power sources simultaneously. Failure to install proper electric components can result in property damage and equipment malfunction.
- Maintain polarity throughout the communication network. The system will malfunction if not properly wired.

Figure 82: Multi F with LGRED LMU240HHV System Power Wiring and Communications Cable Connections.

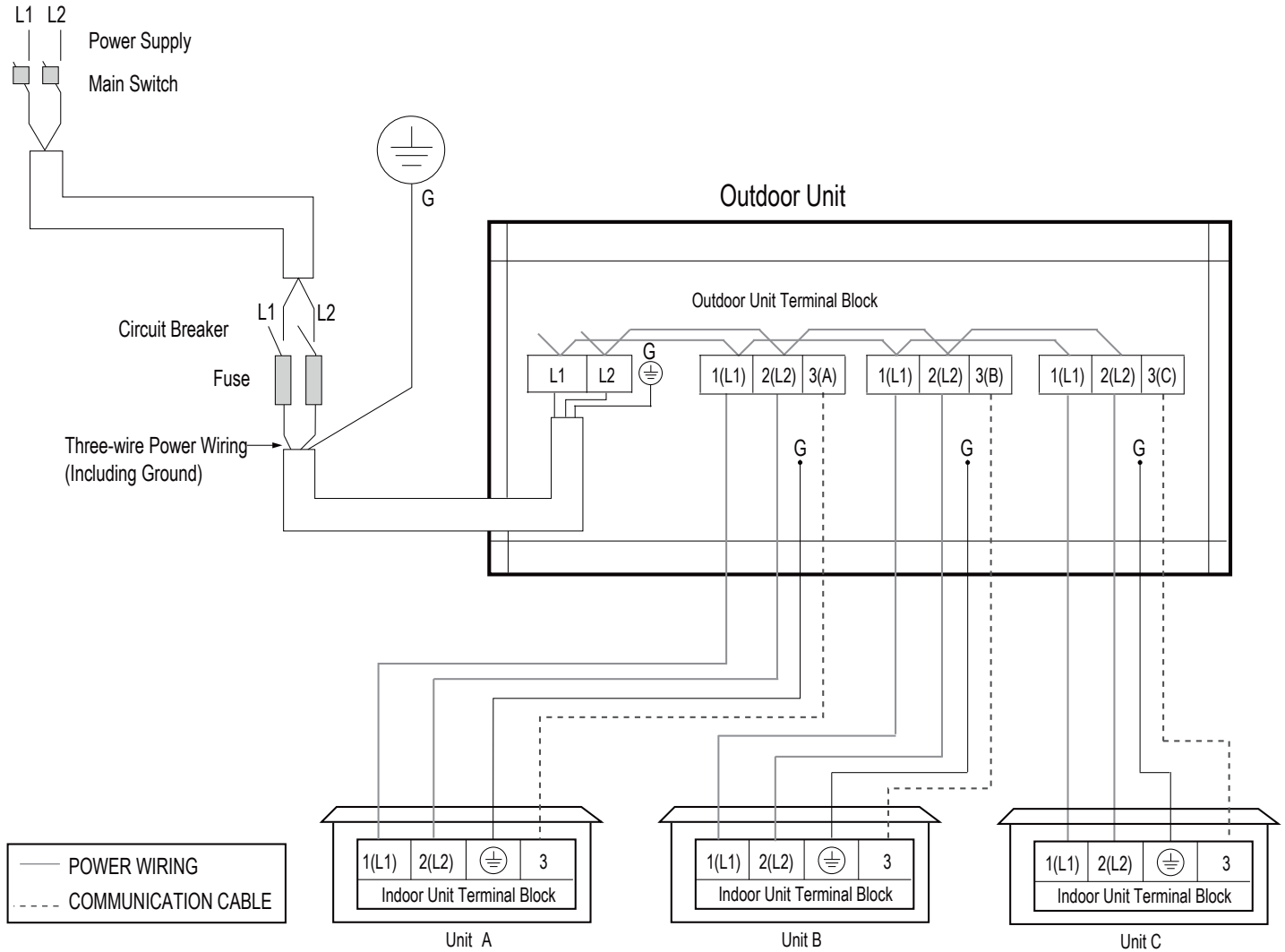

**⚠ WARNING**

- All field-supplied wiring, components, sizes, and materials must comply with all applicable national, state, and local codes and requirements. Improper wiring will result in fire, electric shock, physical injury or death.
- Ground wiring is required to prevent accidental electrical shock during current leakage, communication problems from electrical noise, and motor current leakage. ⚠ Do not connect the ground line to the pipes. There is a risk of fire, electric shock, explosion, physical injury or death.
- Install a main shutoff switch or circuit breaker that interrupts all power sources simultaneously. There is a risk of fire, electric shock, explosion, physical injury or death.

**Note:**

- All field-supplied wiring, components, sizes, and materials must comply with all applicable national, state, and local codes and requirements. Failure to install proper electrical components can result in property damage and equipment malfunction.
- Ground wiring is required to prevent communication problems from electrical noise, and motor current leakage. Failure to provide proper ground wiring can result in property damage and equipment malfunction.
- Install a main shutoff switch or circuit breaker that interrupts all power sources simultaneously. Failure to install proper electric components can result in property damage and equipment malfunction.
- Maintain polarity throughout the communication network. The system will malfunction if not properly wired.

Figure 83: Multi F with LGRED LMU300HHV System Power Wiring and Communications Cable Connections.

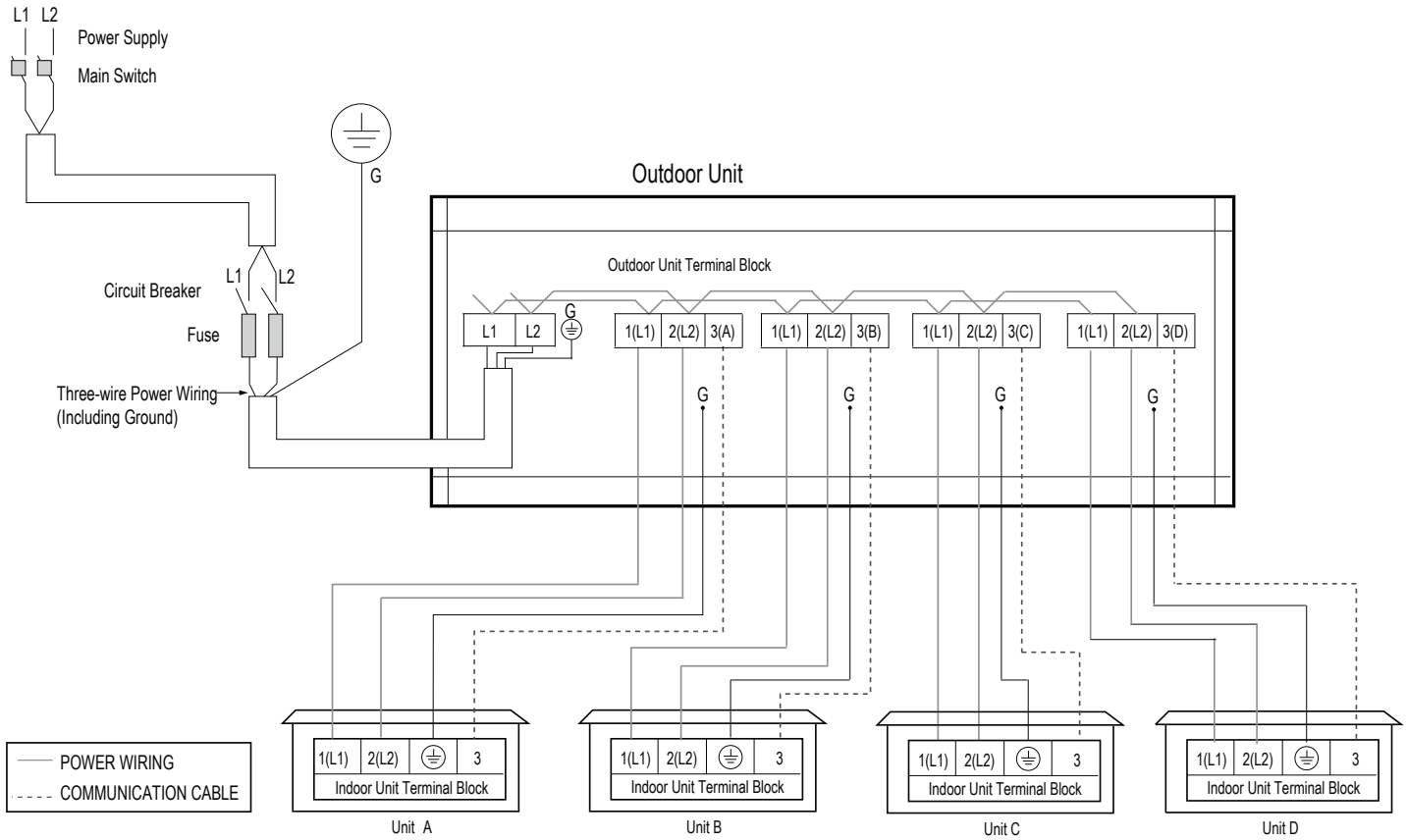

### ⚠ WARNING

- All field-supplied wiring, components, sizes, and materials must comply with all applicable national, state, and local codes and requirements. Improper wiring will result in fire, electric shock, physical injury or death.
- Ground wiring is required to prevent accidental electrical shock during current leakage, communication problems from electrical noise, and motor current leakage. ⚡ Do not connect the ground line to the pipes. There is a risk of fire, electric shock, explosion, physical injury or death.
- Install a main shutoff switch or circuit breaker that interrupts all power sources simultaneously. There is a risk of fire, electric shock, explosion, physical injury or death.

### Note:

- All field-supplied wiring, components, sizes, and materials must comply with all applicable national, state, and local codes and requirements. Failure to install proper electrical components can result in property damage and equipment malfunction.
- Ground wiring is required to prevent communication problems from electrical noise, and motor current leakage. Failure to provide proper ground wiring can result in property damage and equipment malfunction.
- Install a main shutoff switch or circuit breaker that interrupts all power sources simultaneously. Failure to install proper electric components can result in property damage and equipment malfunction.
- Maintain polarity throughout the communication network. The system will malfunction if not properly wired.

Figure 84: Multi F MAX with LGRED LMU361HHV, LMU421HHV, and LMU480HHV System Power Wiring and Communications Cable Connections.

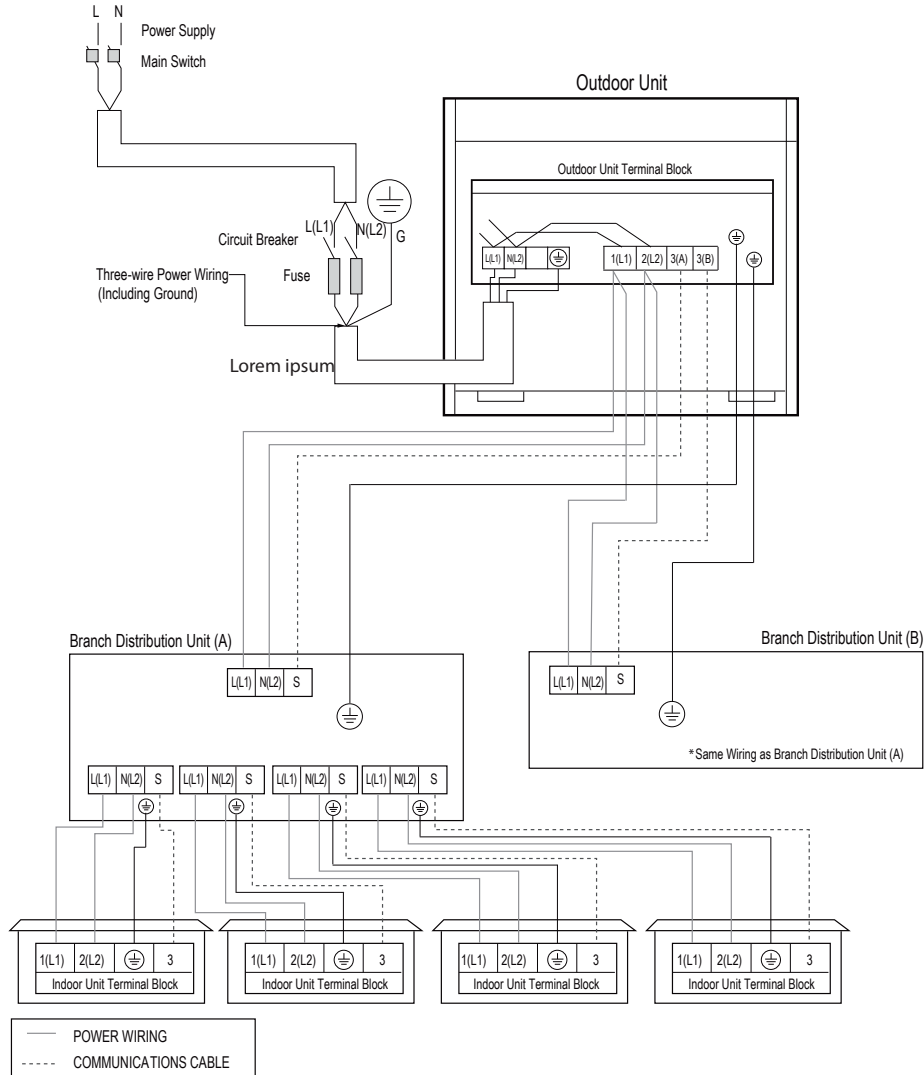

**WARNING**

- All field-supplied wiring, components, sizes, and materials must comply with all applicable national, state, and local codes and requirements. Improper wiring will result in fire, electric shock, physical injury or death.
- Ground wiring is required to prevent accidental electrical shock during current leakage, communication problems from electrical noise, and motor current leakage. ⚠ Do not connect the ground line to the pipes. There is a risk of fire, electric shock, explosion, physical injury or death.
- Install a main shutoff switch or circuit breaker that interrupts all power sources simultaneously. There is a risk of fire, electric shock, explosion, physical injury or death.

**Note:**

- All field-supplied wiring, components, sizes, and materials must comply with all applicable national, state, and local codes and requirements. Failure to install proper electrical components can result in property damage and equipment malfunction.
- Ground wiring is required to prevent communication problems from electrical noise, and motor current leakage. Failure to provide proper ground wiring can result in property damage and equipment malfunction.
- Install a main shutoff switch or circuit breaker that interrupts all power sources simultaneously. Failure to install proper electric components can result in property damage and equipment malfunction.
- Maintain polarity throughout the communication network. The system will malfunction if not properly wired.

### Connecting the Communications / Connection (Power) Cables

1. Detach the outdoor unit panels by loosening the screws.
2. Remove the control cover (if applicable) by loosening the screws.
3. Remove the conduit knock outs on the access holes.
4. Pull the power wiring, and the communications / connection (power) cable into the outdoor unit (through the conduits, if applicable). Ensure there is enough length to connect to the terminals on the outdoor unit. Secure any conduits with field-supplied lock nuts.
5. Connect the power wiring, and the communications / connection (power) cable to the correct terminals on the outdoor unit.
6. Connect communications / connection (power) cable to the correct control board terminals on the indoor unit (or branch distribution unit[s] if Multi F MAX with LGRED system).
7. Follow the wiring diagrams on the outdoor unit and indoor units (or branch distribution unit[s]) control covers. Ensure that the terminal board numbers and wiring color on the outdoor unit matches the terminal number and wiring color on the indoor unit or branch distribution unit(s).
8. Provide strain relief and help protect the connections by (separately) securing the wiring / cable to the outdoor unit with the factory-supplied clamps (up to 35 lbs.). Clamps are included near the terminal block. Zip ties can also be used to hold all cables in place.
9. For more installation information for specific indoor units, refer to the separate indoor unit installation manuals on [www.lghvac.com](http://www.lghvac.com).
10. When all connections are complete, reattach the control cover to its original position using the screws, then reinstall the outdoor unit panel.
11. After installation is complete, seal any gaps around the wiring in the panel access holes or the conduits.

Figure 85: Multi F with LGRED Outdoor Unit Wiring Connections (LMU300HHV Example).

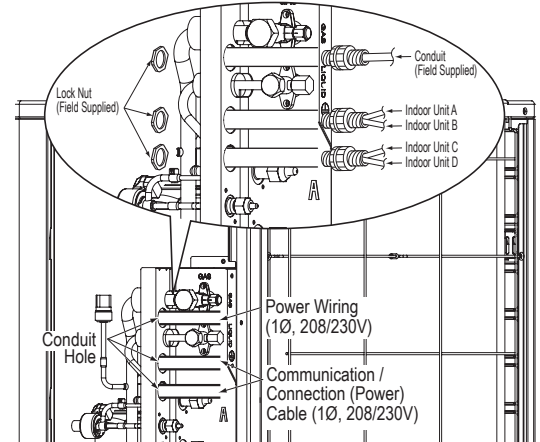
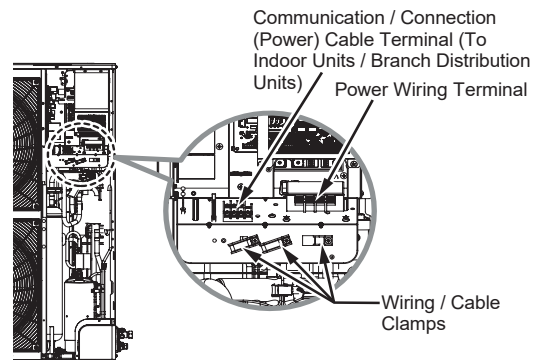

Figure 86: Multi F MAX with LGRED Outdoor Unit Wiring Connections Close Up View.



### ⚠ WARNING

- Always have a trained technician properly ground the outdoor unit. If the outdoor unit is not properly grounded, there is a risk of electric shock, physical injury, or death.
- Failure to properly install wiring can result in electric shock, fire, physical injury or death.
- Failure to properly provide a NEC-approved earth ground can result in electric shock, fire, physical injury or death.
- Comply with local and national codes while running the wire from the indoor unit (and branch distribution units if Multi F MAX with LGRED system) to the outdoor unit (size of wire and wiring method, etc). Incorrectly sized wiring will cause the terminal to overheat, generate a fire, and risk physical injury or death.
- All wiring / cable must be firmly connected to its terminals. Loose wiring will cause the terminal to overheat, generate a fire, and risk physical injury or death.
- Do not allow the wiring / cable to touch refrigerant tubing, the compressor, or any moving parts. It can result in electric shock, fire, physical injury or death.
- Replace all control box and panel covers. If cover panels are not installed securely, dust, water and animals may enter the outdoor unit, causing fire, electric shock, and physical injury or death.

### Note:

- Ensure the communications / connection (power) cable from the outdoor units to the indoor / branch distribution units, and the power wiring to the outdoor unit are separate; otherwise, the outdoor unit operation will be affected by electrical noise and will malfunction.
- The communications / connection (power) cable from the outdoor unit to the indoor / branch distribution units must be separated and isolated from power wiring to the outdoor unit, computers, elevators, radio and television broadcasting facilities, as well as medical imaging equipment; otherwise, the outdoor unit operation will be affected by electrical noise and will malfunction or fail.
- All wiring / cable must be firmly connected to its terminals. Loose wiring will result in unit malfunction.

Figure 87: Detailed Diagrams of Outdoor Unit PCB Terminal Connections.

LMU180HHV / LMU240HHV (18 / 24 kBtu/h)

LMU300HHV (30 kBtu/h)

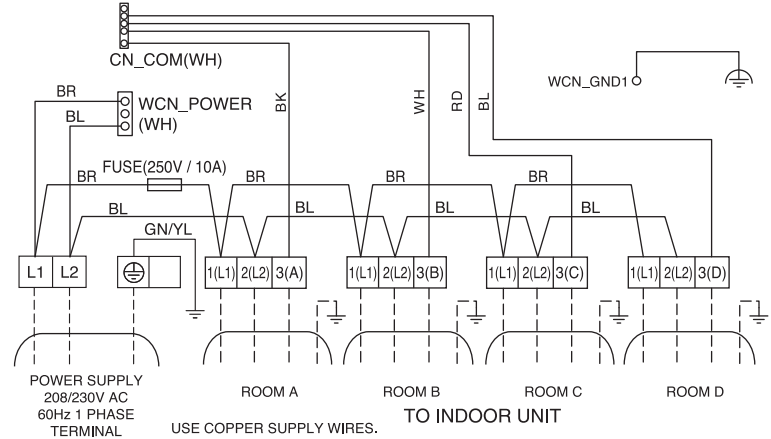
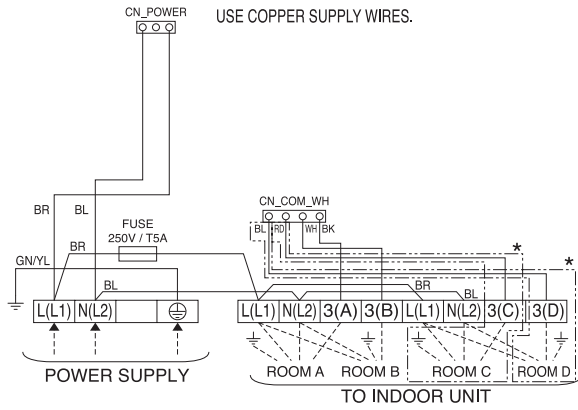

LMU361HHV / LMU421HHV / LMU480HHV (36 / 42 / 48 kBtu/h)

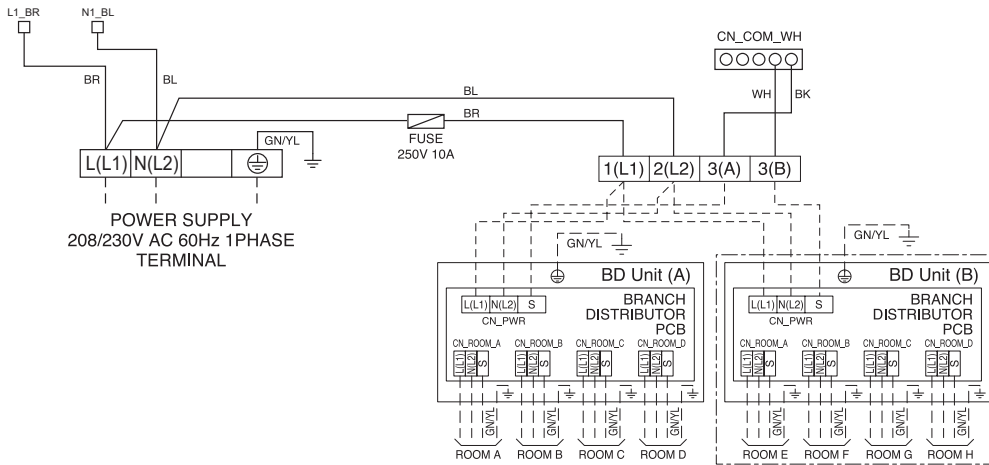

### Connecting the Communications / Connection (Power) Cable to the Branch Distributor Unit (Multi F MAX with LGRED Systems Only)

#### General Instructions

- Always connect power wiring / communications cable matching the branch distribution unit terminals to their respective indoor units (Example for three-port branch distribution unit PMBD3630: A, B, and C).
- Follow the instructions on the nameplates and connect wiring / cables of the outdoor unit and indoor units to the correct terminals. Always attach each ground wire separately to a grounding screw.
- After completion, secure wiring with wire clamps. Secure wiring firmly to the indoor unit.

Figure 88: Interior View of a Branch Distribution Unit (Three-Port PMBD3630 Example Shown).

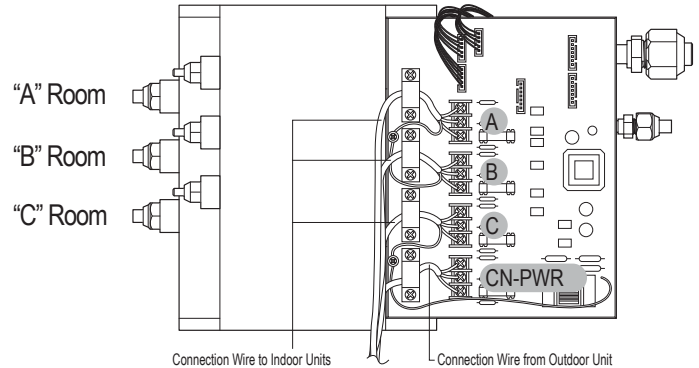

#### Branch Distribution Unit Wiring Connection Procedure

1. Remove the branch distribution unit control cover. Unscrew the two (2) screws, and slide the cover off the branch distribution frame following the arrows in the diagram (Step 1).
2. Pull the communications / connection (power) cable from the outdoor unit so there is enough length to connect to the terminals on the branch distribution unit. Secure a field-supplied conduit to the branch distribution unit using a field-supplied lock nut on the interior of the branch distribution unit frame (Step 2). Pull the communication / connection (power) cable through the conduit into the branch distribution unit.
3. Connect communications / connection (power) cable from the outdoor unit to the branch distribution unit terminals, and from the branch distribution unit terminals to the indoor unit terminals following the wiring diagram on the outdoor unit control cover (Step 3). Allow 11-3/16 inches of slack in the wire harness. Attach communications / connection (power) cable to the branch distribution unit with clamps at four (4) locations.
4. Replace the branch distribution unit control cover following the arrows in the diagram. Tighten the two (2) screws to finish (Step 4).

Figure 89: Branch Distribution Unit Wiring Steps.

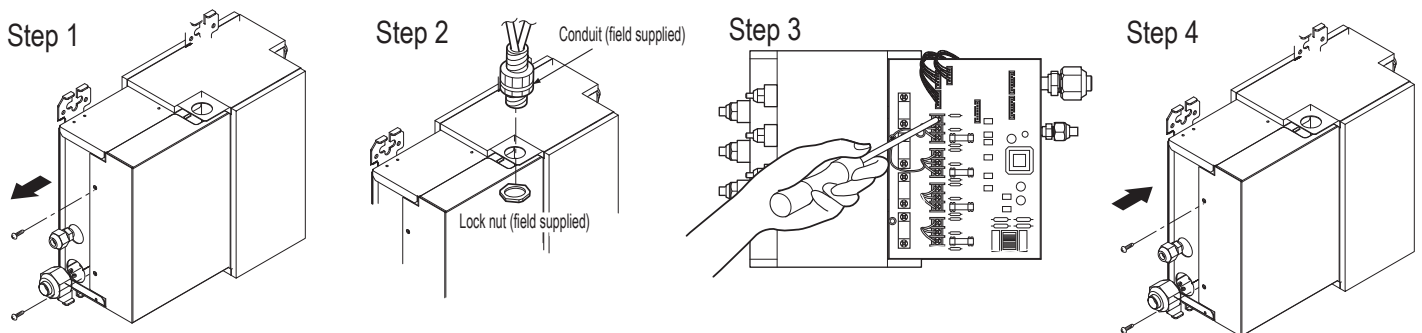

#### ⚠ WARNING

⊘ Do not use tapped wires, stand wires, extension cords, or starburst-type connections as they will cause overheating, fire, electric shock, physical injury or death.

#### Note:

Always refer to the circuit diagram on the inside of the outdoor unit control cover.

### PI-485

PI-485 V-net Control Integration Board for Outdoor Units adapt Multi F / Multi F MAX with LGRED systems to a LG VRF system central protocol for integration with LG central controllers. The PI-485 is installed in the Multi F / Multi F MAX with LGRED outdoor unit. For more information on PI-485 installation, see the PI-485 installation manual.

Figure 91: PI-485 Installation Area in Multi F and Multi F MAX with LGRED Outdoor Units.

Figure 90: PI-485 Board (Appearance will differ depending on model).



#### LMU180HHV, LMU240HHV (18 / 24 kBTu/h)

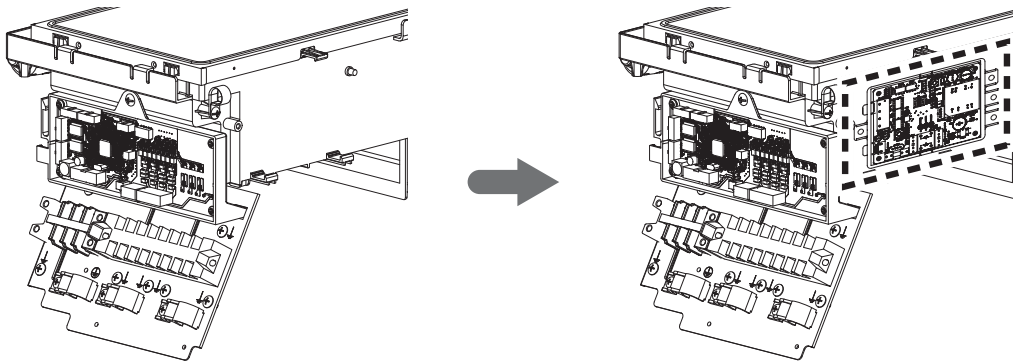

#### LMU300HHV (30 kBTu/h)

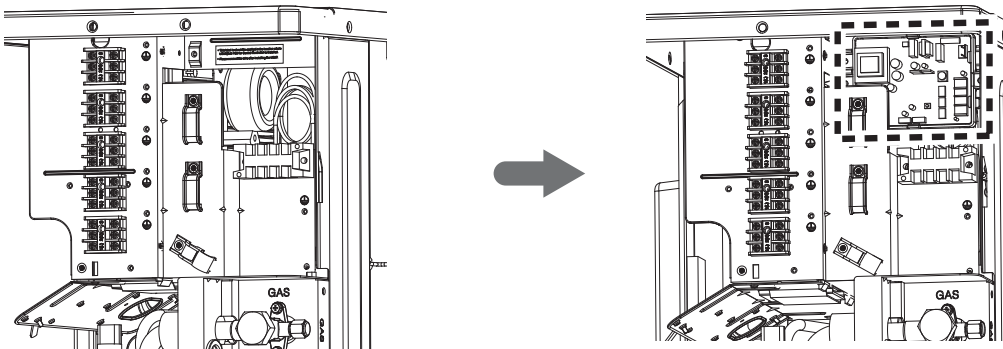

#### LMU361HHV, LMU421HHV, LMU480HHV (36 / 42 / 48 kBTu/h)

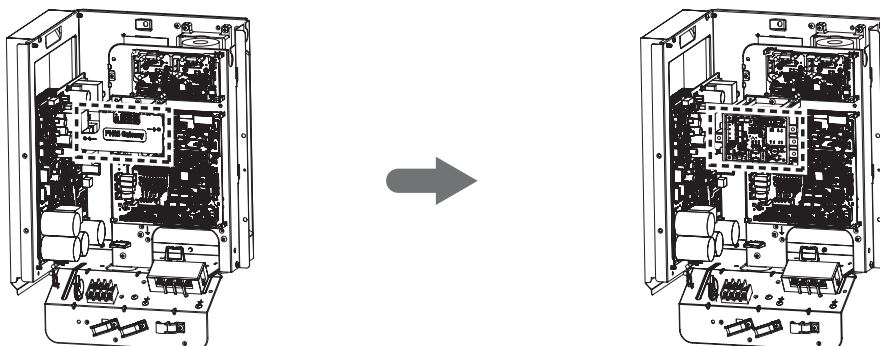

### From Indoor Units to Remote Controllers

- Communication cable from indoor unit to remote controller(s) is to be LG supplied or field supplied 22 AWG, 3-conductor, twisted, stranded, unshielded. Wiring must comply with all applicable local and national codes.
- If using the LG supplied cable and the length needs to be extended, the LG Extension Kit (sold separately) must be used. A maximum of four (4) kits (up to 165 feet) can be used.
- Remote controllers have hardwired connections: SIG - 12V - GND (Comm.) terminals.
- Indoor unit controller connections depend on type of indoor unit being installed. Some indoor units use terminal block connections; other indoor units use Molex connections. See diagrams below for the two options. Refer to the wiring diagram schematic found in the indoor unit itself, or to the indoor unit wiring diagrams in the Engineering Manuals for more information.
- ⚠ NEVER splice, cut, or extend LG supplied cable with field provided cable. Always include enough cable to cover distance between the indoor unit and the remote controller.
- Set the indoor unit operating parameters using DIP switches, or by setting up the remote controller. Refer to the indoor unit installation manuals for more details.

Figure 92: One Example of Indoor Unit to Zone Controller Connection.

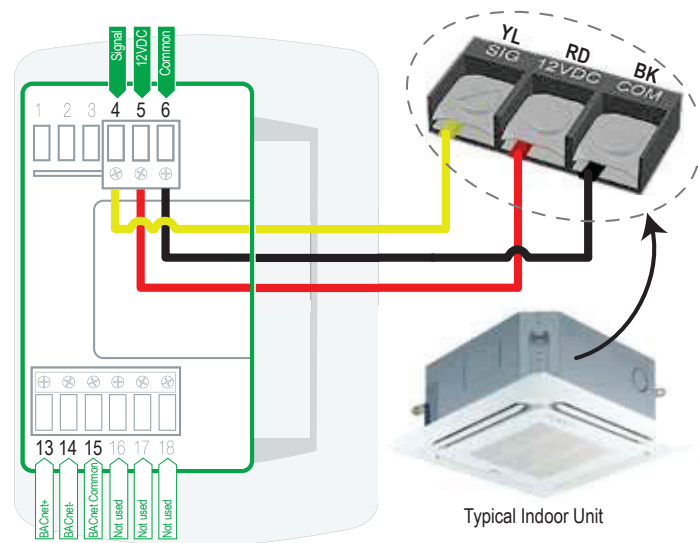

#### Note:

Cable connected to Zone Controller is the factory default connection.

Figure 93: Another Example of Indoor Unit to Zone Controller Connection.

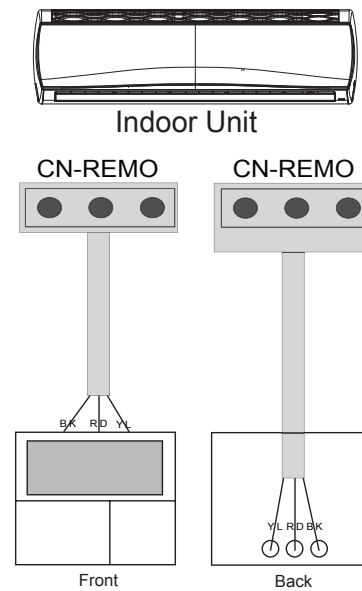

## Between Multiple Indoor Units Operating as a Group (Group Control)

### If any indoor units were specified to operate in unison:

- Before running cable, decide which indoor unit will be the "Main." The other indoor units in that group will be designated as "Sub(s)." The zone controller will be connected to the "Main."
- Set the pertinent DIP switch at each indoor unit to identify the Main and Sub(s). On wall mounted indoor unit models, set the assignment using the handheld remote controller.
- Use a daisy chain configuration and connect all of the group's indoor units together starting at the "Main" unit.
- Ⓝ NEVER splice, cut, or extend cable length with field provided cable. Always include enough cable to cover distance between all components.

### For indoor units with hardwired connections SIG - 12V - GND (Comm.) terminals:

- From the controller to the main indoor unit, use 22 AWG, 3-conductor, twisted, stranded, unshielded. All wiring must comply with all applicable local / national codes.
- From the main indoor unit to the sub indoor unit(s), daisy chain using 22 AWG, 3-conductor, twisted, stranded, unshielded. All wiring must comply with all applicable local / national codes.
- (Ⓝ Do not attach wire to 12VDC terminal to the sub indoor units). All wiring must comply with all applicable local and national codes.
- Ⓝ NEVER splice, cut, or extend cable length; always include enough cable to cover distance between all components.

### For indoor units with CN-REMO connections:

Use one (or multiple) Group Control Kit(s) (sold separately) containing extension and Y-splitter cables. Use one (1) group control cable kit for each indoor unit in the group except for the last indoor unit. Ⓝ NEVER splice, cut, or extend cable length with field provided cable.

### Note:

- Cable connected to zone controller is the factory default connection.
- Indoor unit connections depend on indoor unit type.

### General Specifications

- Wired remote controllers can be connected to all indoor unit types.
- Wireless controllers can be used in conjunction with wired remote controllers.
- A dry contact unit can be connected with a central controller simultaneously.
  - The main indoor unit is recognized by the dry contact unit and the central controller.
  - Group Control only available for indoor units manufactured after February 2009.
  - The central controller can control indoor units after setting the address of the main indoor unit only.
  - Sub indoor unit cannot be individually controlled by central controller.
  - Sub indoor unit will operate like main indoor unit.
- If an error occurs with the indoor unit, the error will be displayed on the wired remote controller.
- The following functions are available with group control:
  - Selection of operation options (operation/mode/set temperature)
  - Control of air flow rate (High/Medium/Low)

Figure 94: Example of Indoor Unit Group to Zone Controller Connections (Sig-12V-GND [Comm.] Terminal).

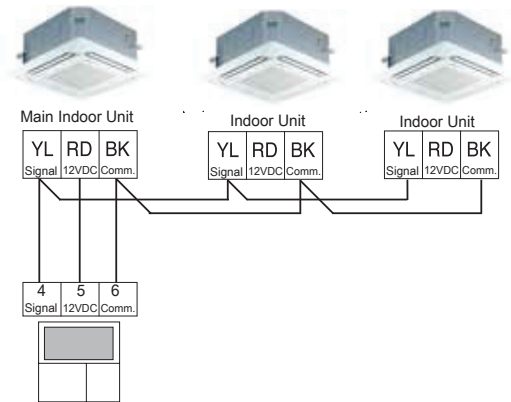

Figure 95: Example of Indoor Unit Group to Zone Controller Connections (CN-REMO).

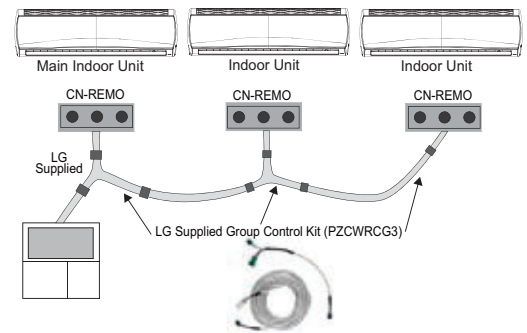

Table 33: Accessories for Some Group Control Applications.

Accessory	Model Number	Image
Wired Remote Group Control Cable Assembly, Required for connecting multiple indoor units to a control group	PZCWRCG3	
Wired Remote/Wired Remote Extension Cable, Required for extending the distance between indoor units or remote controllers in a control group	PZCWRC1	

## Triple Leak / Pressure Test

### Triple Leak / Pressure Test

After the refrigerant piping installation is complete, perform a triple leak / pressure test. Triple leak / pressure test is performed between the outdoor unit and indoor units (and branch distribution units [Multi F MAX with LGRED only]) to verify that refrigerant can flow through the system without danger of leaks or pressure losses. Air and moisture that is left in the piping can lead to undesirable results and can cause damage to the system. It is important to go through a complete leak / pressure cycle to be sure that the refrigerant piping is cleared out. This process will have to be repeated if any air or moisture be is found to remain in the piping.

#### Note:

Insufficient or incorrectly done air purging will lead to the following:

- Pressure in the system can rise.
- Operating current can rise.
- Inefficient cooling or heating mode capability.
- Moisture in the refrigerant circuit will freeze and block capillary tubing.
- Water can lead to corrosion of parts in the system.

#### ⚠ DANGER

Using combustible gases, including oxygen will result in fire or explosion, resulting in personal injury or death. Use inert gas (medical-grade dry nitrogen) when checking leaks, cleaning, installing/repairing pipes, etc. The use of at least 800 psig nitrogen regulator is required for safety.

#### Note:

- ⚠ Do not apply power to the system before performing a system leak test. There is a possibility that the EEV valve may close and isolate sections of the piping system, making the leak test inconclusive.
- ⚠ Never perform the leak test using refrigerant.
- To avoid nitrogen entering the refrigerant system in a liquid state, the top of the cylinder must be higher than its bottom (used in a vertical standing position) when the system is pressurized.
- Use only a leak-free gauge manifold set.
- Piping system must not be pressured to more than 550 psi. Pressures greater than 550 psi will damage the piping system and cause unit malfunction.

#### Triple Leak / Pressure Check Procedure

1. After the refrigerant piping installation is complete, open the isolation ball valves, if any, that may have been installed in the piping system.
2. Verify that both the liquid and gas (vapor) suction line outdoor unit service ports are closed, and the stem head access caps are tight. The leak / pressure check is to be performed only to the refrigerant piping system, and all connected indoor units and branch distribution units (Multi F MAX with LGRED units only).
3. Remove the caps on both the liquid and gas (vapor) suction Schrader ports. Connect the (medical-grade dry) nitrogen cylinder regulator to a gauge manifold, then connect the gauge manifold to the Schrader ports on the service ports.
4. Perform the leak / pressure check at 150 psig for fifteen (15) minutes (standing pressure check).
5. Perform the leak / pressure check at 300 psig for thirty (30) minutes (standing pressure check).
6. Perform the leak / pressure check at 550 psig for one (1) hour to make sure the piping system is leak-free. After the gauge reading reaches 550 psig, isolate the system by first closing the gauge manifold, then close the nitrogen cylinder valve. Check the flared (and any brazed connections) for leaks by applying a bubble solution to all joints. Also test for leaks at both service valves.

Figure 96: Triple Leak / Pressure Test Diagram.

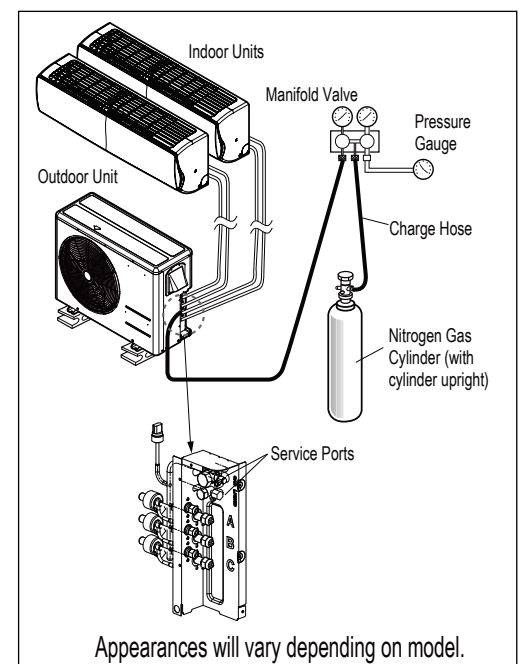

### Triple Leak / Pressure Check Procedure, continued.

**Note:**

The bubble solution must be a solution designed for refrigerant leak testing. Common soap solution must  never be used on refrigerant piping as those contain chemicals that could corrode copper and brass, and cause product malfunction.

7. If the pressure does NOT drop for one (1) hour, the system passes the test.
8. If the pressure drops, there is a leak and it must be found. Remove the bubble solution with a clean cloth, repair the leak(s), and perform the leak / pressure check again.
9. After the system has been thoroughly tested and no leaks are present, depressurize by loosening the charging hose connector at the nitrogen cylinder regulator. When system pressure returns to normal, completely disconnect the charging hose from the cylinder, and release the nitrogen charge from all refrigerant piping. Wipe off any remaining bubble solution with a clean cloth.

### Deep Evacuation Procedure

On Multi F systems, after the leak / pressure check is complete, the deep evacuation procedure must be performed to the refrigerant piping and all connected indoor units. On Multi F MAX systems, the triple evacuation procedure (seen on page 74) must be performed. Deep evacuation must be performed through the Schrader ports on the outdoor unit service ports.

**Note:**



The triple evacuation procedure seen on page 74 is a best practices recommendation for Multi F systems, but mandatory for Multi F MAX systems.

**Note:**

For faster evacuation, the Schrader core can be removed, and an auxiliary service port can be used. Make sure to re-install the original Schrader core before operating the system.

- Deep evacuate through both the liquid and gas (vapor) suction Schrader ports on the outdoor unit service ports.
- The outdoor unit service valves must remain closed and the stem head access caps tight.  Do not open the outdoor unit service valves and release the factory refrigerant charge until trim charge is complete, and the system is ready to operate.
- Any field-installed ball valves in the refrigerant system (if used) must be open to ensure all piping is free and clear for deep evacuation on all piping and connected indoor units.

**Note:**

-  Do not apply power to the system before performing the deep evacuation procedure. There is a possibility that the EEV valve will close and isolate sections of the piping system, making the deep evacuation procedure inconclusive.
-  Never perform evacuation using refrigerant.
- Use only a vacuum pump that can reach 500 microns, vacuum rated hoses or copper tubing, and a leak-free gauge manifold set.
- Use only new vacuum pump oil from a properly sealed (unopened) container, and change oil in pump before EVERY use.
- Subsequent oil changes will be necessary after several hours of continuous operation; have extra oil on hand.
- Use a quality micron gauge in good operating order and install as far away from pump as possible.

### Deep Evacuation Procedure Steps

1. If this procedure is performed shortly after the leak / pressure test, the cap and core on the liquid and gas (vapor) suction Schrader ports must have already been removed, and the manifold must already be connected. If the procedure was not performed shortly after the leak / pressure test, make sure to remove the cap and core on the liquid and gas (vapor) suction Schrader ports. Verify that the service valves on the outdoor unit are closed, and the stem head access caps are tight.
2. Connect the gauge manifold along with the vacuum pump to the liquid and gas (vapor) suction Schrader ports (with core removed) using a vacuum hose. Open the gauge manifold and the vacuum pump valves.

# FINAL INSTALLATION PROCEDURES

MULTI F WITH LGRED<sup>®</sup>  
MULTI F MAX

## Deep Evacuation / Triple Evacuation Tests

### Deep Evacuation Procedure, continued.

3. Evacuate to static micron level  $\leq 500$  for at least one (1) hour.
4. Micron level must remain  $\leq 500$  for two (2) hours. If the vacuum gauge rises and stops, the system may contain moisture; therefore, it will be necessary to repeat the steps of vacuum break and drying.
5. After maintaining the system in vacuum  $\leq 500$  micron for two (2) hours, check if the vacuum gauge rises or not. If it doesn't rise, then the system is properly evacuated.
6. Close manifold gauges.
7. Shut the valves before turning off and disconnecting the vacuum pump.

Figure 97: Evacuation Procedure Diagram.

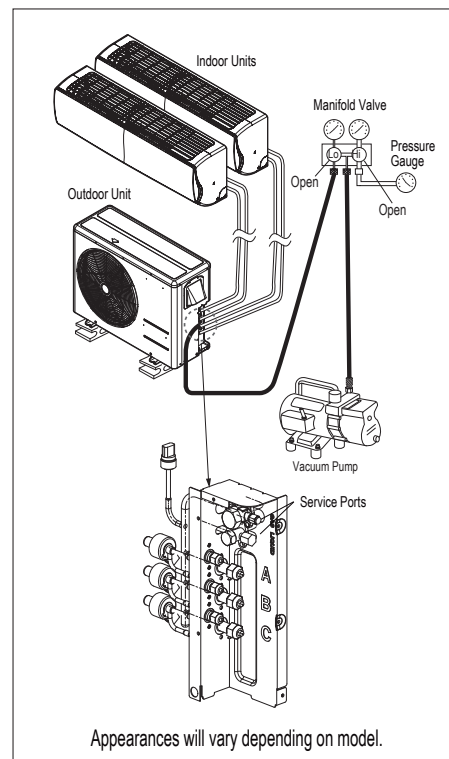

### Triple Evacuation Procedure

On Multi F MAX systems, after the leak / pressure check is complete, the triple evacuation procedure must be performed to the refrigerant piping and all connected indoor units / branch distribution units. ⚠ Do not just perform the deep evacuation procedure on Multi F MAX systems. The deep evacuation procedure is insufficient to fully evacuate the extensive piping systems on Multi F MAX products. Triple evacuation must be performed through the Schrader ports on the outdoor unit service ports.

#### Note:

The triple evacuation procedure is a best practices recommendation for Multi F systems, but mandatory for Multi F MAX systems.

#### Note:

For faster evacuation, the Schrader core can be removed, and an auxiliary service port can be used. Make sure to re-install the original Schrader core before operating the system.

- Evacuate through both the liquid and gas (vapor) suction Schrader ports on the outdoor unit service ports.
- The outdoor unit service valves must remain closed and the stem head access caps tight. ⚠ Do not open the outdoor unit service valves and release the factory refrigerant charge until trim charge is complete, and the system is ready to operate.
- Any field-installed ball valves in the refrigerant system (if used) must be open to ensure all piping is free and clear for evacuation on all piping and connected indoor units / branch distribution units.

#### Note:

- ⚠ Do not apply power to the system before performing the evacuation procedure. There is a possibility that the EEV valve may close and isolate sections of the piping system, making the evacuation procedure inconclusive.
- ⚠ Never perform evacuation using refrigerant.
- Use only a vacuum pump that can reach 500 microns, vacuum rated hoses or copper tubing, and a leak-free gauge manifold set.
- Use only new vacuum pump oil from a properly sealed (unopened) container, and change oil in pump before EVERY use.
- Subsequent oil changes will be necessary after several hours of continuous operation; have extra oil on hand.
- Use a quality micron gauge in good operating order and install as far away from pump as possible.

### Triple Evacuation Procedure Steps

1. If this procedure is performed shortly after the leak / pressure test, the cap and core on the liquid and gas (vapor) suction Schrader ports must have already been removed, and the manifold must already be connected. If the procedure was not performed shortly after the leak / pressure test, make sure to remove the cap and core on the liquid and gas (vapor) suction Schrader ports. Verify that the service valves on the outdoor unit are closed, and the stem head access caps are tight.
2. Connect the gauge manifold along with the vacuum pump to the liquid and gas (vapor) suction Schrader ports (with core removed) using a vacuum hose. Open the gauge manifold and the vacuum pump valves.

**Note:**

- After the vacuum pump is first operated, if hoses, manifold, and vacuum valves are leak free (and oil is not moisture laden), the gauge must read <100 microns within one (1) minute.
  -  Do not proceed if the gauge does not read <100 microns within one (1) minute. There is a leak in the hose, gauge manifold, or vacuum valve, and the equipment must be replaced.
3. Operate the vacuum pump and evacuate the system to the 2,000 micron level. Isolate the pump by closing the manifold gauges and the vacuum pump valve, and then watch the micron level. Micron level will rise a bit, but MUST eventually stop rising for fifteen (15) minutes.
    - If the micron level DOES NOT stop rising, there is a leak, and the leak test must be performed again.
    - If the micron level DOES rise above 2,000 micron, re-open the manifold gauges and the vacuum pump valve and continue evacuation back down to 2,000 micron level.
    - If the micron level holds at 2,000 micron, continue to step 4.
  4. Break vacuum with 50 psig nitrogen purge for an appropriate amount of time (this is to “sweep” moisture from piping).
  5. Purge nitrogen from the system until the pressure drops down to 1 to 3 psig.
  6. Evacuate to 1,000 micron level. Isolate the pump by closing the manifold gauges and the vacuum pump valve, and then watch the micron level. Micron level will rise a bit, but MUST eventually stop rising for fifteen (15) minutes.
    - If the micron level DOES NOT stop rising, there is a leak, and the leak test must be performed again.
    - If the micron level DOES rise above 1,000 micron, re-open the manifold gauges and the vacuum pump valve, and continue evacuation back down to 1,000 micron level.
    - If the micron level holds at 1,000 micron, continue to step 7.
  7. Break vacuum with 50 psig nitrogen purge for an appropriate amount of time.
  8. Purge nitrogen from the system until the pressure drops down to 1 to 3 psig.
  9. Evacuate to static micron level  $\leq 500$  for at least one (1) hour.
  10. Micron level must remain  $\leq 500$  for one (1) hour. If the vacuum gauge rises and stops, the system may contain moisture; therefore, it will be necessary to repeat the steps of vacuum break and drying (Steps 7 through 9).
  11. After maintaining the system in vacuum  $\leq 500$  micron for one (1) hour, check if the vacuum gauge rises or not. If it doesn't rise, then the system is properly evacuated.
  12. Close manifold gauges.
  13. Shut the valves before turning off and disconnecting the vacuum pump.

# FINAL INSTALLATION PROCEDURES

MULTI F WITH LGRED<sup>®</sup>  
MULTI F MAX

## Refrigerant Charge

LG Multi F and Multi F MAX with LGRED outdoor units ship from the factory with a charge of R410A refrigerant. A trim charge may need to be added to take into account additional piping length.

To determine the additional refrigerant that is needed, apply the formulas below, and record the results. If the total additional refrigerant charge value is a negative number, then an additional trim charge does not need to be added to the system.

Table 34: Outdoor Unit Factory Charge.

Outdoor Unit	Factory Charge oz. of R410A
LMU180HHV	98.8
LMU240HHV	112.8
LMU300HHV	112.8
LMU361HHV	183.4
LMU421HHV	183.4
LMU480HHV	183.4

### Multi F with LGRED Systems

$$\begin{aligned} \text{Additional charge (lbs.)} &= (\text{Installed Length of Branch [A]} - \text{Chargeless Pipe Length [L]}) \times a \\ &+ (\text{Installed Length of Branch [B]} - \text{Chargeless Pipe Length [L]}) \times a \\ &+ (\text{Installed Length of Branch [C]} - \text{Chargeless Pipe Length [L]}) \times a \\ &+ (\text{Installed Length of Branch [D]} - \text{Chargeless Pipe Length [L]}) \times a \\ &- \text{CF (Correction Factor)} \times 5.29 \end{aligned}$$

#### Note:

- Number of installed length of branches depends on the specifications of the outdoor unit model.
- CF = Maximum number of connectible indoor units – Total number of connected indoor units.

Table 35: Multi F with LGRED Outdoor Unit Piping Specifications.

Outdoor Unit Model	Min. to Max. Piping Length for One Branch (ft.)	Max. Total System Piping Length (ft.)	Chargeless Pipe Length per Branch (L) (ft.)	Piping Length (No Additional Refrigerant [ft])	Additional Charge Needed (a) (oz./ft.)
LMU180HHV	9.8 to 82	164	24.6	49.2	0.22
LMU240HHV	9.8 to 82	246.1	24.6	73.8	0.22
LMU300HHV	9.8 to 82	246.1	24.6	98.4	0.22

Figure 98: Multi F with LGRED Additional Refrigerant Charge Example.

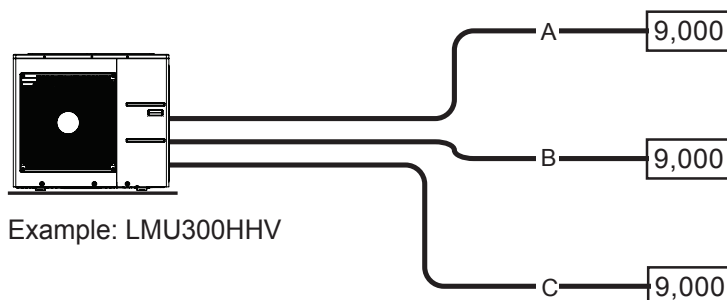

Each branch pipe  
A = 82 ft.  
B = 16 ft.  
C = 49 ft.

$$\begin{aligned} \text{Additional Charge} &= (82 - 24.6) \times 0.22 \\ &+ (16 - 24.6) \times 0.22 \\ &+ (49 - 24.6) \times 0.22 \\ &- (4 - 3) \times 5.29 \\ &= 10.82 \text{ oz.} \end{aligned}$$

### Multi F MAX with LGRED Systems

Additional charge (lbs.) = (Total Main Piping Length [A] - Chargeless Pipe Length of Main Pipe [L]) x a  
 + (Total Installed Length of Branch [B1+B2+B3...] - Chargeless Branch Length [B]) x b  
 - CF (Correction Factor) x 3.53

**Note:**

- Number of installed length of branches depends on system specifications.
- CF = Maximum number of connectible indoor units – Total number of connected indoor units

Table 36: Multi F MAX with LGRED Outdoor Unit Piping Specifications.

Outdoor Unit Model	Main Piping Length		Branch Piping Length	
	Chargeless Pipe Length of Main Pipe (L) (ft.)	Additional Charge Needed (a) (oz./ft.)	Chargeless Pipe Length of Branch Pipe (ΣB) (ft.)	Additional Charge Needed (b) (oz./ft.)
LMU361HHV	49.2	0.54	131.2	0.22
LMU421HHV	49.2	0.54	131.2	0.22
LMU480HHV	49.2	0.54	131.2	0.22

Figure 99: Multi F MAX with LGRED Additional Refrigerant Charge Example.

LMU421HHV

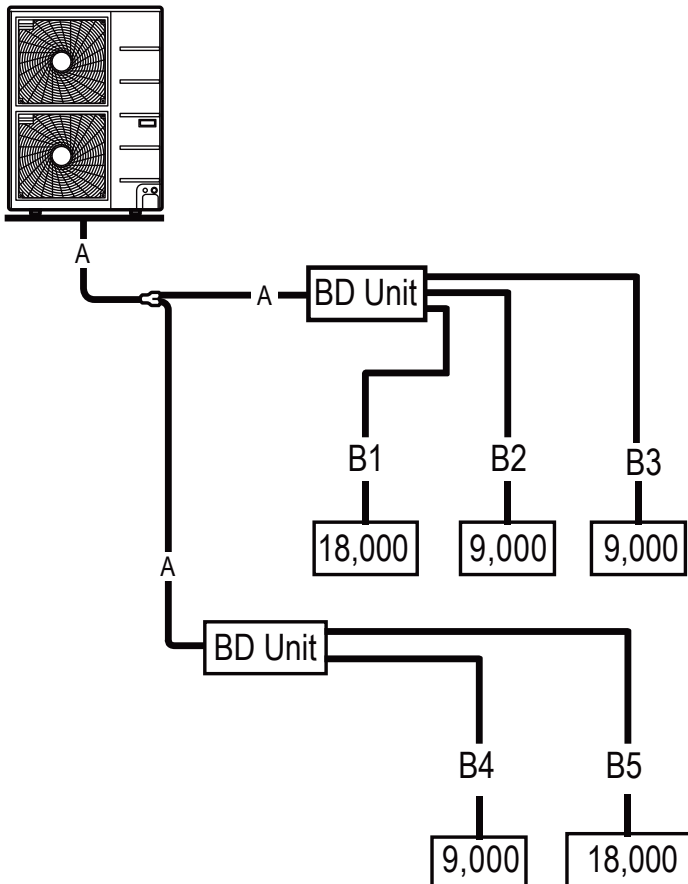

- Total main pipe (A) = 90 ft.
- Each branch pipe  
 B1 = 49 ft.  
 B2 = 17 ft.  
 B3 = 17 ft.  
 B4 = 10 ft.  
 B5 = 23 ft.

Additional Charge  
 = (90 - 49.2) x 0.54  
 + (116 - 131.2) x 0.22  
 - (6 - 5) x 3.53  
 = 15.16 oz.

## Refrigerant Charge

### Refrigerant Charge

1. Determine the additional refrigerant amount that is needed, Trim Charge, applying the necessary formulas as outlined in the previous pages.
2. Connect the charging cylinder to the charge hose on the manifold valve.
3. Purge air from the charge hose by opening the valve at the bottom of the cylinder, and press the check valve on the manifold valve.
4. Confirm that the "Lo" knob of the manifold valve is open and charge the system with liquid refrigerant. (Because R-410A is a non-azeotrope refrigerant, it must be charged in the liquid state.)
  - If the required amount of refrigerant cannot be charged all at once, the refrigerant can be charged a little at a time (approximately 5.29 ounces) while the system operates in cooling. This procedure must be repeated until the entire amount of refrigerant gets charged into the system; perform once, then wait approximately one [1] minute before resuming.
5. Immediately disconnect the charge hose from the service port on the three-way valve. Stopping halfway allows the refrigerant to discharge.
  - If the system has been charged with liquid refrigerant while it operates, turn the system off before disconnecting the hose.
6. Mount the valve stem nuts and the service port nut. Use torque wrench to tighten the service port nut to a torque of 1.8 kg.m and check for leaks.

#### ⚠ WARNING

When installing or relocating the outdoor unit, make sure that no substance other than the specified refrigerant (R410A) enters the refrigerant circuit. The presence of foreign substances such as air can cause an abnormal pressure rise and will result in explosion and physical injury.

Figure 100: Charging the Refrigerant.

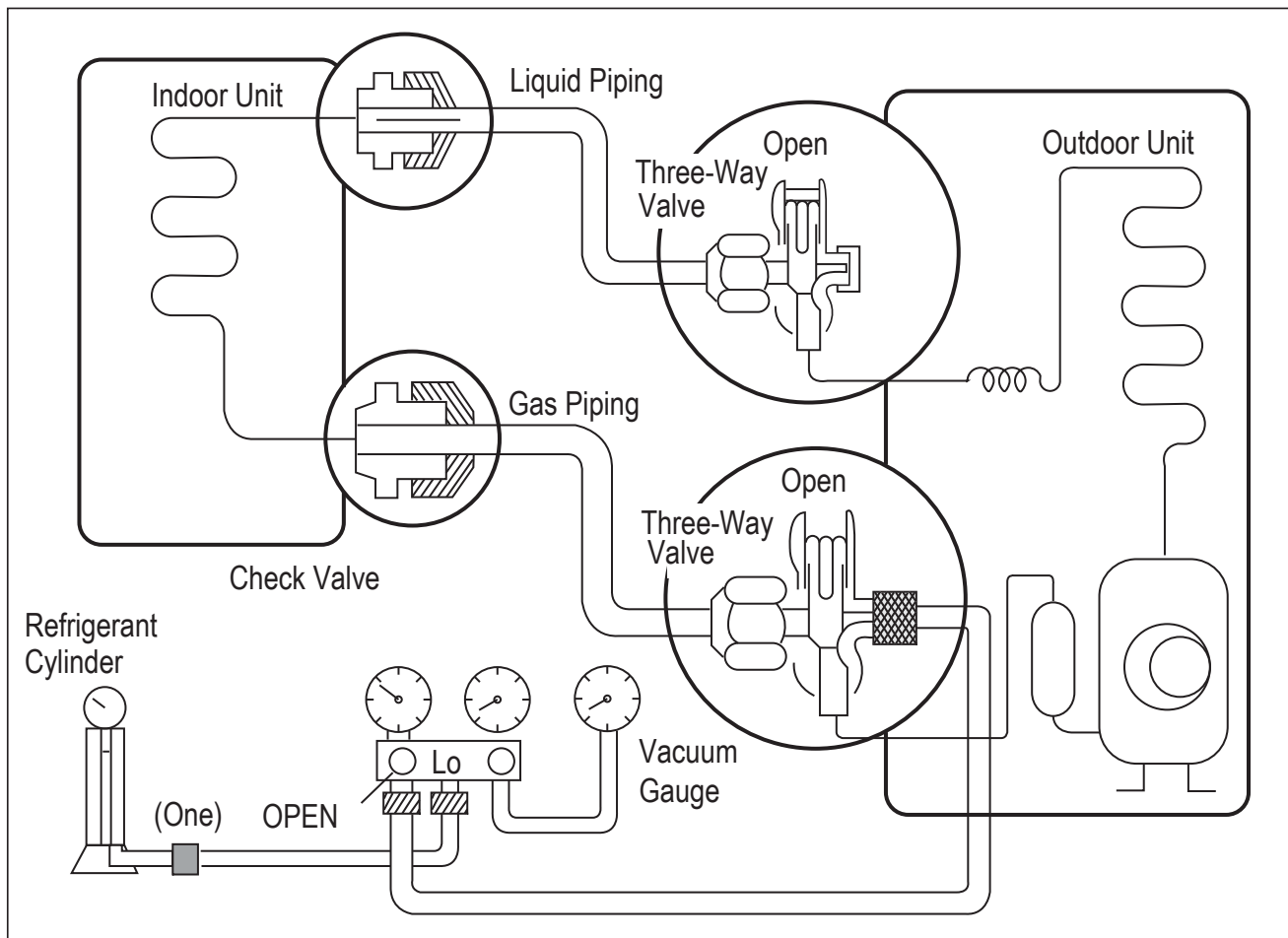

### Cautions for Refrigerant Leaks / Introduction

ASHRAE Standards 15 and 34 offer guidelines that address refrigerant safety and the maximum allowable concentration of refrigerant in an occupied space. Refrigerant will dissipate into the atmosphere, but a certain volume of air is required for this to occur safely. For R410A refrigerant, the maximum allowable concentration is 0.026 lbs./ft<sup>3</sup> per 1,000 ft<sup>3</sup> of air in an occupied space. Buildings with twenty-four (24) hour occupancy allow half of that concentration.<sup>1</sup>

ASHRAE Standards 15 and 34 assume that if a system develops a leak, its entire refrigerant charge will dump into the area where the leak occurs. To meet ASHRAE Standards 15 and 34, calculate the refrigerant concentration that will occur in the smallest room volume on the system, and compare the results to the maximum allowable concentration number (see below for information on how to calculate the refrigerant concentration).<sup>1</sup> Also consult state and local codes in regards to refrigerant safety.

#### **⚠ WARNING**

Verify the maximum refrigerant concentration level in the space where the indoor unit will be mounted meets the concentration limit for the application. If the refrigerant leaks and safety limits are exceeded, it could result in personal injuries or death from oxygen depletion.

#### **Note:**

Take appropriate actions at the end of HVAC equipment life to recover, recycle, reclaim or destroy R410A refrigerant according to applicable US EPA rules.

To calculate the potential refrigerant concentration level (RCL):

1. Measure the occupied space dimensions (in feet).
2. Calculate the cubic foot volume of air in the smallest occupied space. (To obtain a detailed overview of the RCL, perform the same calculations to the second smallest zone, the third smallest zone until the RCL is obtained for all zones. Also, pay special attention to areas such as basements, etc., where refrigerant cannot dissipate easily.)
3. Divide the refrigerant charge of the Multi Zone system serving the area in pounds by the results of step 1.
4. If the calculation indicates that the potential refrigerant concentration level is higher than the allowed RCL, increase the cubic volume of the smallest occupied space or modify the piping system design.
5. The allowable RCL limit for most applications must be equal to or less than 0.026 lbs./ft<sup>3</sup>. However, in special occupied spaces, such as hospitals and nursing homes, where occupants will have limited mobility, the allowable RCL limit is cut in half. See ASHRAE Standard 34 and local codes for detailed information.<sup>1</sup>

Figure 101: Example of R410A Refrigerant Leak Location.

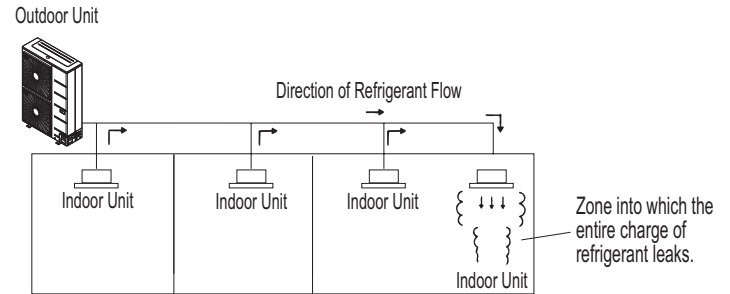

### Refrigerant Concentration Limit (RCL) Calculations

To calculate total refrigerant amount per system:

<b>Amount of Factory-Charged Refrigerant per Outdoor Unit</b>	<b>+</b>	<b>Amount of Additional Refrigerant Trim Charge</b>	<b>=</b>	<b>Total System Refrigerant Charge</b>
---	----------	---	----------	--

$$\text{RCL (lbs./ft}^3\text{)} = \frac{\text{Total System Refrigerant Charge (lbs.)}}{\text{Volume of Smallest Occupied Space (ft}^3\text{)}}$$

<sup>1</sup>American Society of Heating, Refrigeration and Air Conditioning Engineers, Inc. (ASHRAE). Atlanta, GA. ASHRAE, Inc. Information about ASHRAE Standard 15 / 34 and addenda current as of the date of this publication.

## Cautions for Refrigerant Leaks

To determine the volume of an occupied space, the designer must also determine which ones are connected, not connected, or ventilated (refer to Standard 34).

If the calculated RCL is above the allowable limit, there are two primary methods used to lower the RCL:

1. Increase the volume of the occupied space.
2. Decrease the size of the refrigerant charge.

Per Standard 34-2007, acceptable methods used to increase the volume of an occupied space include:

- Install transfer ducts between rooms.
- Undercut and overcut doors (partitions  $\leq 0.15\%$  of cubic volume of space within a zone).
- Add an opening without a door (partitions  $\leq 0.15\%$  of cubic volume of space within a zone).
- Include ventilation grilles in doors; include ventilation inlets / outlets (partitions  $\leq 0.15\%$  of cubic volume of space within a zone).
- Include the area above the ceiling as part of the return or supply air path (partitions  $\leq 0.15\%$  of cubic volume of space within a zone).
- Install a mechanical ventilator linked to a gas leak detector.
- Change the indoor unit type (wall mounted to ceiling cassette) / position.

Figure 102: Examples of Zones.

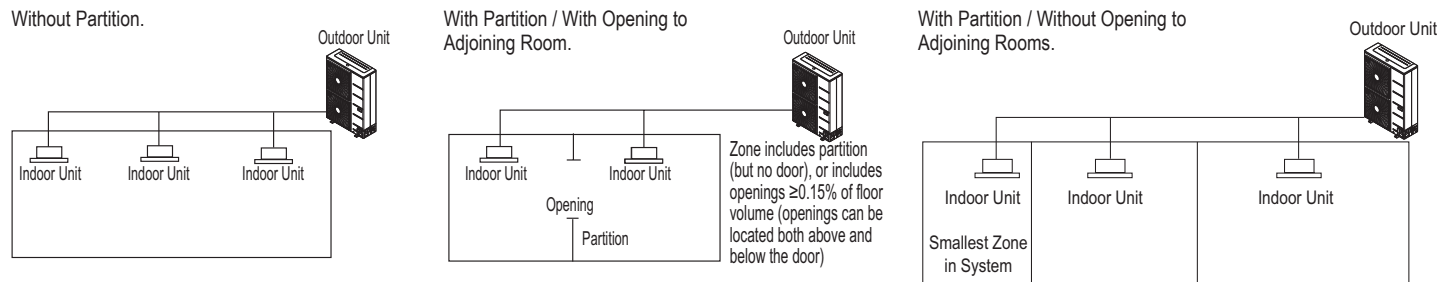
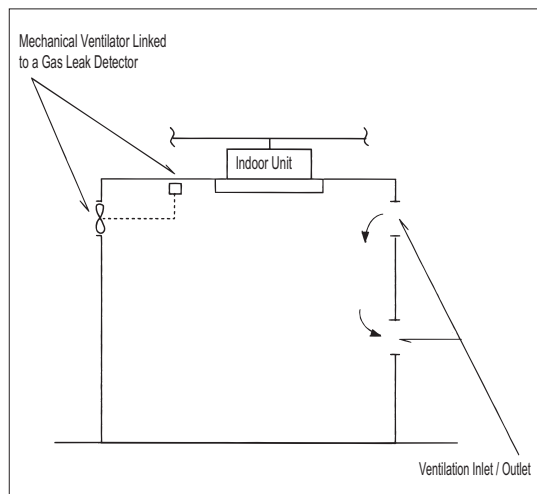

Figure 103: Example of Acceptable Ventilation Methods.



### Note:

See also the LG HVAC Building Ventilation Guide on [www.lghvac.com](http://www.lghvac.com).

### Test Run

After the triple leak / pressure and evacuation procedures are complete, perform a test run.

#### Before the Test Run

1. Check that all condensate tubing, refrigerant piping and power wiring, and communication / connection (power) cables are properly connected.
2. Make sure that the gas and liquid service valves are fully open.

#### Test Run Procedure

1. Operate the system in cooling mode for 15 to 20 minutes.
2. Evaluate performance as the system runs, verifying the outdoor unit, and all indoor units and branch distribution units (Multi F MAX with LGRED systems only) are working properly. Make notes as needed to address any issues that might be found.
  - Check the system refrigerant charge:
    - Measure the pressure from the gas side service valve.
    - Measure the indoor unit inlet and outlet air temperatures. Verify the difference between the intake temperature and the discharge is more than 15°F.
    - See table below for the optimum condition of the gas side pressure (again, system is in cooling mode).

Table 37: Optimum Conditions of the Gas Side Pressure.

Refrigerant Type	Outside Ambient Temperature	Gas Side Service Valve Pressure
R410A	95°F	120~135 psig

Figure 105: Inlet and Outlet Temperature Locations on Various Indoor Units.

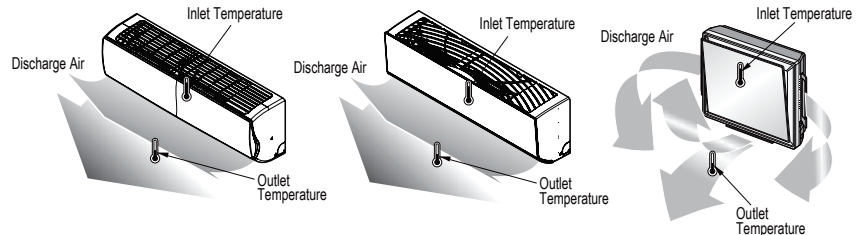

#### Note:

If the pressure is >135 psig, the system is most likely overcharged, and refrigerant must be removed. If the pressure is <120 psig, the system is most likely undercharged and refrigerant must be added.

### Installing the Remote Controller Batteries

As part of the test run, the batteries need to be inserted into the remote controller, and the remote controller will need to be powered on to operate the indoor units (depending on the indoor units included in the system). To insert the batteries follow the steps below. For information on using the remote controller, refer to its owner's manual.

1. The remote controller needs two (2) AAA (1.5V) batteries for operation. ⚠ Do not use rechargeable batteries. Remove the battery cover from the back of the remote controller by pushing downward on the tab at the top of the battery cover and then lift up to remove.
2. Insert the two new batteries. Align batteries by the (+) and (-) sides (the interior battery compartment of the remote controller will have clear markings for the (+) and (-) placement).
3. Verify that the batteries have "clicked" into the compartment and are firmly engaged with the contacts on either side.
4. Reattach the back cover of the remote controller.
5. Proceed with powering on the remote controller and usage as needed.

Figure 106: Installing the Remote Controller Batteries.

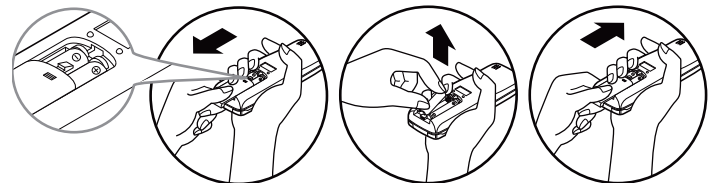
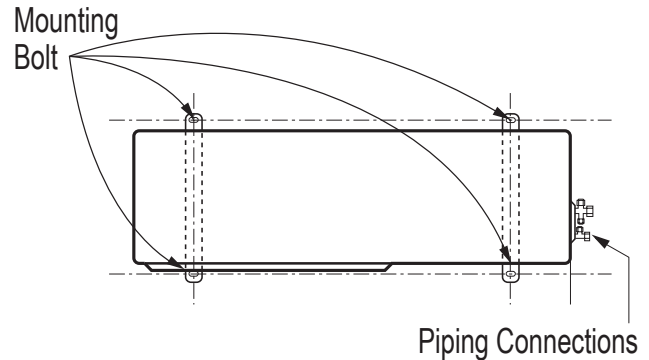

Figure 104: Piping Connection on the Outdoor Unit (Will Differ Depending on Outdoor Unit Model).



# FINAL INSTALLATION PROCEDURES

## DIP Switch Settings for Optional Modes

MULTI F WITH LGRED<sup>®</sup>  
MULTI F MAX

### Outdoor Unit DIP Switch Settings

System must be powered off, and then turned back on to apply DIP switch settings.

#### ⚠ WARNING

Turn off the circuit breaker or shut off the power source of the product before setting the DIP switch. There is risk of physical injury or death due to electric shock.

#### Note:

- Unless the applicable DIP switch is set properly, the system will not work.
- If a specific function is desired, request that the installer set the appropriate DIP switch during installation.
- Only the first four DIP switches are functional on the LMU361, 421, 480HHV.

Figure 107: LMU180, 240, 300HHV Outdoor Unit DIP Switches (in Normal Operation Setting).

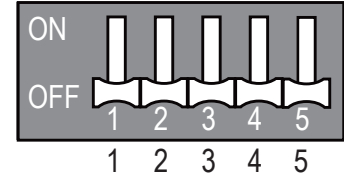

Figure 108: LMU361, 421, 480HHV Outdoor Unit DIP Switches (in Normal Operation Setting).

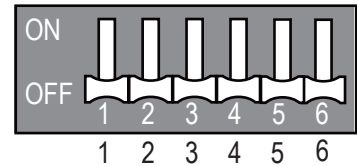

Table 38: DIP Switch Settings and Functionalities.

DIP Switch Setting	Function
	Normal Operation (No Function)
	Forced Cooling Operation
	Wiring Error Check
	Reducing Power Consumption (Step 1)
	Reducing Power Consumption (Step 2)
	Mode Lock (Cooling)
	Mode Lock (Heating)
	Night Quiet Mode (Step 1)
	Night Quiet Mode (Step 2)
	Mode Lock (Cooling) + Night Quiet Mode (Step 1)
	Mode Lock (Cooling) + Night Quiet Mode (Step 2)
	Reducing Power Consumption (Step 1) with Mode Lock (Cooling)
	Reducing Power Consumption (Step 2) with Mode Lock (Cooling)
	Reducing Power Consumption (Step 1) with Mode Lock (Heating)
	Reducing Power Consumption (Step 2) with Mode Lock (Heating)

### Location of DIP Switches on Multi F and Multi F MAX Outdoor Units

Figure 109: Multi F with LGRED (LMU180-240-300HHV) Outdoor Unit DIP Switch Locations.

LMU180 / 240 / 300HHV  
(18 / 24 / 30kBtu/h)

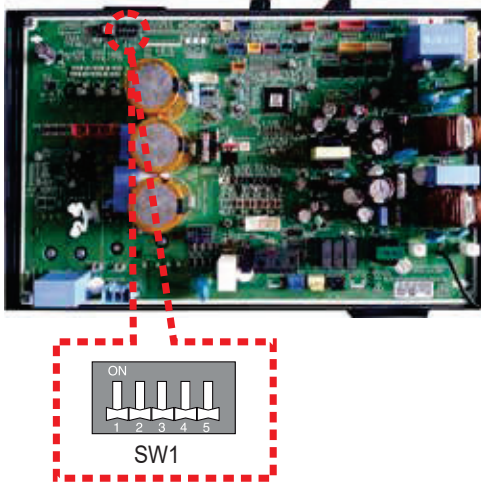
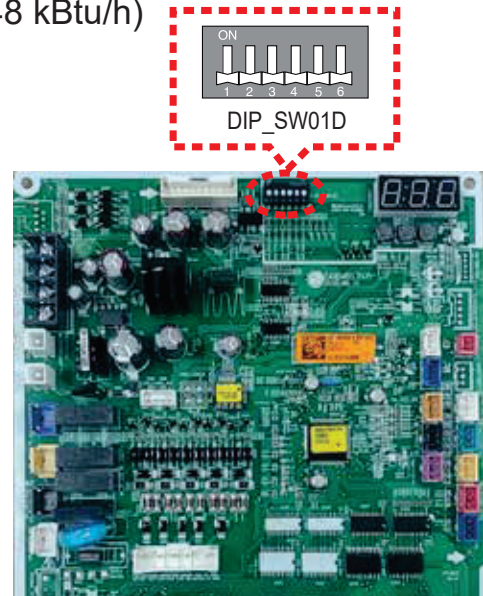

Figure 110: Multi F MAX with LGRED (LMU361-421-480HHV) Outdoor Unit DIP Switch Locations.

LMU361HHV / LMU421HHV / LMU480HHV  
(36 / 42 / 48 kBtu/h)



### Forced Cooling Operation Function

Use to add refrigerant to the system when outside ambient temperatures are cool (ex.: winter).

1. Shut power down to the system.
2. Set DIP Switch 1 to ON.
3. Turn power on to the system.
4. Verify that the Red LED on the outdoor unit PCB is ON (indicates indoor units are in forced cooling operation).
5. Add refrigerant.

#### Note:

- If the green LED light on the outdoor unit PCB is ON, it indicates the compressor is OFF due to low pressure in the system.
- Turn DIP Switch 1 to OFF after finishing (Normal Operation setting).
- Only the first four DIP switches are functional on the LMU361, 421, 480HHV.

Figure 111: LMU180-240-300HHV Forced Cooling DIP Switch Setting.

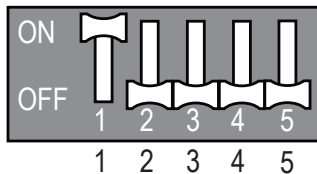
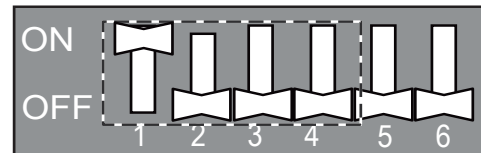

Figure 112: LMU361-421-480HHV Forced Cooling DIP Switch Setting.



# FINAL INSTALLATION PROCEDURES

MULTI F WITH LGRED<sup>®</sup>  
MULTI F MAX

## DIP Switch Settings for Optional Modes

### Wiring Error Check

Use to verify if wiring is properly installed.

1. Shut power down to the system.
2. Set DIP Switch 2 to ON.
3. Turn power on to the system.
4. Check if the Red and Green LEDs on the outdoor unit PCB are ON (indicate indoor units are in forced operation mode).
5. If the wiring is correctly installed, the Green LED will light up. If the wiring is incorrectly installed, the Red and Green LEDs will blink, indicating which part of the system is in error.
  - Red LED = Piping Number
  - Green LED = Wiring Number (Room)

Example: If the Red LED blinks twice and the Green LED blinks three times, the second piping to the third room is in error (see right).

### Note:

- If the indoor unit(s) is/are not communicating properly to the outdoor unit, the Wiring Error Check cannot operate correctly.
- Only the part of the system in error will be displayed. System will operate correctly after the error is fixed.
- If outdoor and indoor temperatures are too low (ex.: winter), the Wiring Error Check function will not operate (Red LED is ON).
- Turn DIP Switch 2 to OFF after finishing (Normal Operation setting).
- Only the first four DIP switches are functional on the LMU361, 421, 480HHV.

### Reducing Power Consumption

Enables more efficient system operation by reducing the maximum power consumption value (reducing the MCA).

1. Shut power down to the system.
2. For Step 1, set only DIP Switch 3 to ON.
3. For Step 2, set only DIP Switch 4 to ON.
4. Turn power on to the system.

Table 39: Reducing Power Consumption Current Levels.

Phase	1Ø	
Model	Multi F with LGRED LMU180HHV, LMU240HHV, LMU300HHV,	Multi F MAX with LGRED LMU361HHV, LMU421HHV, LMU480HHV
Step 1 (A)	12	22
Step 2 (A)	10	21

### Note:

- Reduced Power Consumption reduces outdoor unit capacity.
- Only the first four DIP switches are functional on the LMU361, 421, 480HHV.

Figure 113: LMU180-240-300HHV Wiring Error Check DIP Switch Setting.

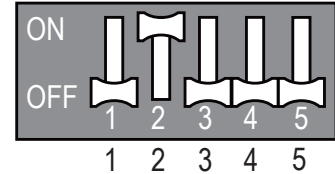

Figure 114: LMU361-421-480HHV Wiring Error Check Example.



Figure 115: Wiring Error Check Example.

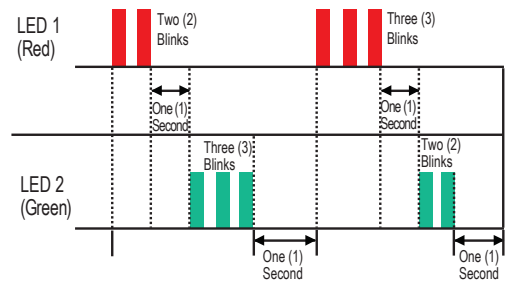

Figure 116: Reducing Power Consumption Chart.

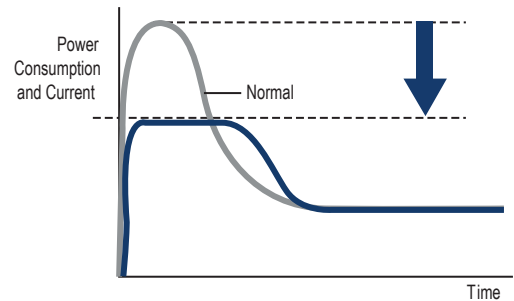

Figure 117: LMU180-240-300HHV Reducing Power Consumption DIP Switch Settings.

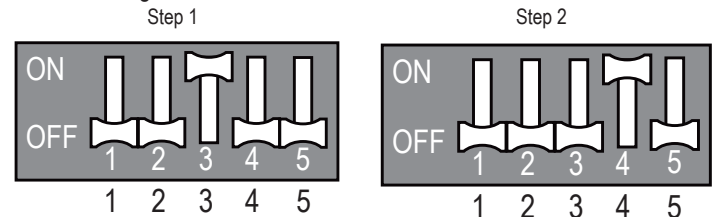
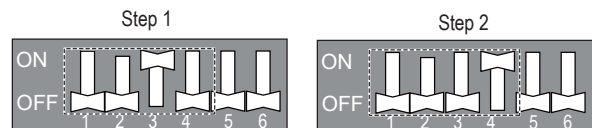

Figure 118: LMU361-421-480HHV Reducing Power Consumption DIP Switch Settings.



### Reducing Power Consumption with Mode Lock

Enables more efficient system operation by lowering the maximum power consumption value, as well as locks the mode of operation (Example: In a cooling-only server room application where permission to adjust the system mode is highly limited). Changing modes can cause a change in compressor frequency, which would cause problems with the setting. As such, if this mode is used, it is locked in either cooling or heating. The function is rarely, if ever, used.

1. Shut power down to the system.
2. Set DIP Switches as indicated below, following the steps and chosen mode.
3. Turn power on to the system.

**Note:**

Only the first four DIP switches are functional on the LMU361, 421, 480HHV.

Figure 119: LMU180-240-300HHV Saving Power Consumption with Mode Lock DIP Switch Settings.

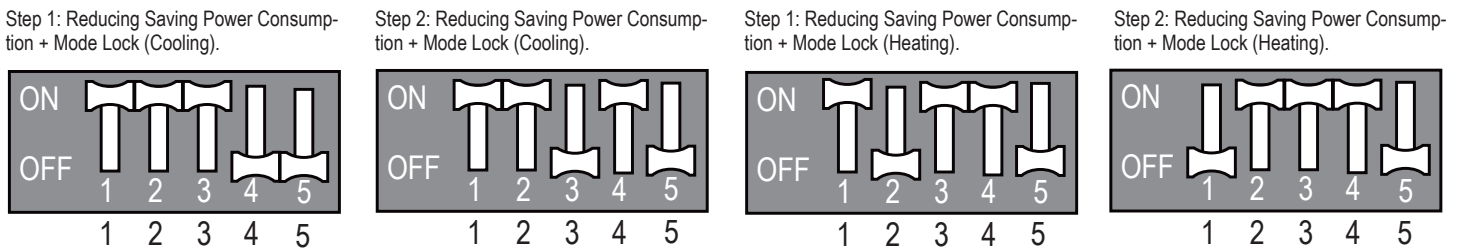
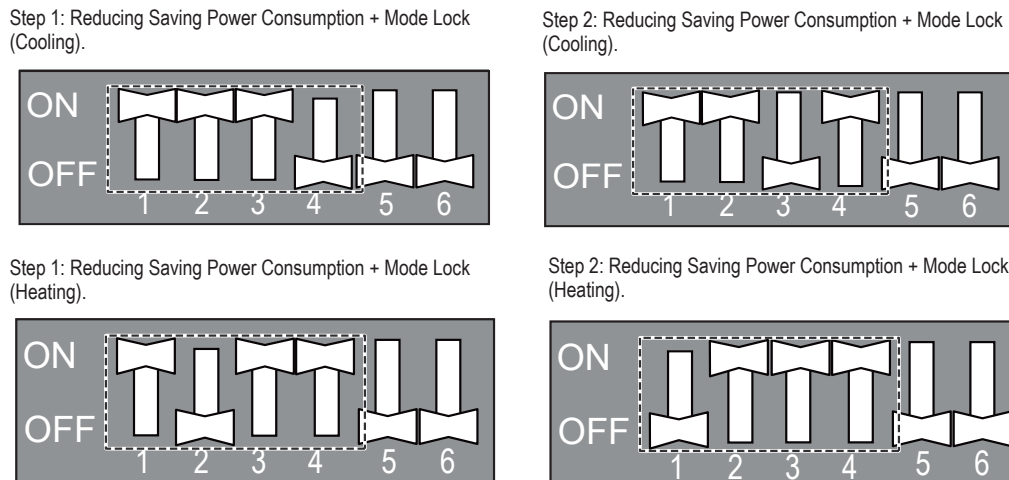

Figure 120: LMU361-421-480HHV Saving Power Consumption with Mode Lock DIP Switch Settings.



# FINAL INSTALLATION PROCEDURES

## DIP Switch Settings for Optional Modes

### Night Quiet Mode

Lowers the operation sound of the outdoor unit by changing the compressor frequency and fan speeds. Night quiet mode initiates eight (8) hours after the highest outdoor air temperature is measured, then is active for nine (9) hours.

1. Shut power down to the system.
2. For Step 1, set only DIP Switches 1 and 4 to ON.
3. For Step 2, set only DIP Switches 2 and 3 to ON.
4. Turn power on to the system.

Figure 121: LMU180-240-300HHV Night Quiet Mode DIP Switch Settings.

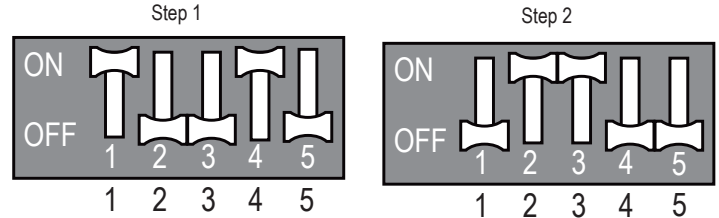
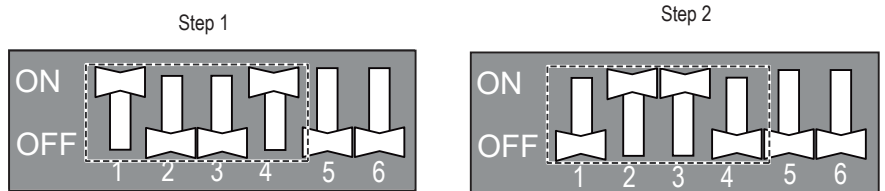

Figure 122: LMU361-421-480HHV Night Quiet Mode DIP Switch Settings.



**Note:**

Operation sound: Step 1 > Step 2.

**Note:**

- If compressor frequency and fan speed are decreased, cooling capacity may also decrease.
- Night Quiet Mode can only be used when system is in cooling operation.
- Change the DIP switches if Night Quiet Mode is no longer desired.
- If indoor unit operation is set by the fan speed "Power", Night Quiet Mode will not function until fan speed "Power" is changed.
- Only the first four DIP switches are functional on the LMU361, 421, 480HHV.

### Mode Lock

Prevents mixed mode operation (mode change) in applications where only one mode is necessary.

1. Shut power down to the system.
2. For Only Cooling Mode Lock, set only DIP Switches 1 and 2 to ON. For Only Heating Mode Lock, set only DIP Switches 3 and 4 to ON.
3. Turn power on to the system.

Figure 123: LMU180-240-300HHV Mode Lock DIP Switch Settings.

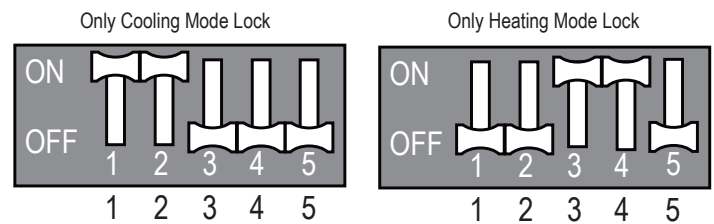
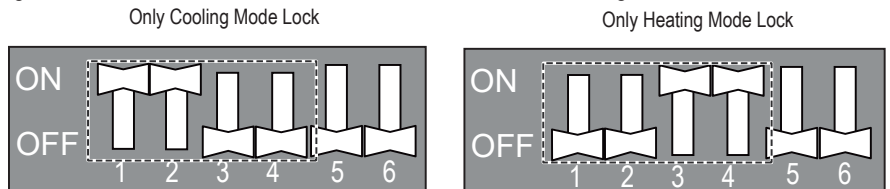

Figure 124: LMU361-421-480HHV Mode Lock DIP Switch Settings.



**Note:**

Only the first four DIP switches are functional on the LMU361, 421, 480HHV.

### Night Quiet Mode with Mode Lock

Lowers the operation sound of the outdoor unit by changing the compressor frequency and fan speeds, as well as locks the mode of operation. Changing modes can cause a change in compressor frequency, which would cause problems with the setting. As such, if this mode is used, it is locked in either cooling or heating. The function is rarely, if ever, used. Night quiet mode initiates eight (8) hours after the highest outdoor air temperature is measured, then is active for nine (9) hours.

1. Shut power down to the system.
2. For Step 1, set only DIP Switches 2 and 4 to ON.
3. For Step 2, set DIP Switches 1 and 3 to ON.
4. Turn power on to the system.

Figure 125: LMU180-240-300HHV Night Quiet Mode with Mode Lock DIP Switch Settings.

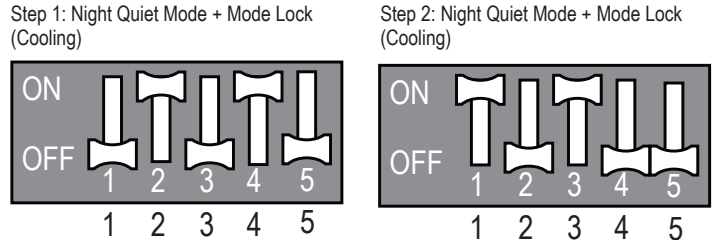
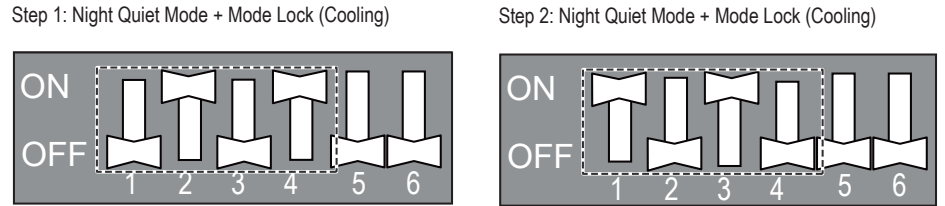

Figure 126: LMU361-421-480HHV Night Quiet Mode with Mode Lock DIP Switch Settings.



**Note:**

- If compressor frequency and fan speed are decreased, cooling capacity may also decrease.
- Night Quiet Mode can only be used when system is in cooling operation.
- Change the DIP switches if Night Quiet Mode is no longer desired.
- If indoor unit operation is set by the fan speed "Power", Night Quiet Mode will not function until fan speed "Power" is changed.
- Only the first four DIP switches are functional on the LMU361, 421, 480HHV.

Table 40: Night Quiet Mode + Mode Lock Settings.

Type	Model Number	Night Quiet	Standard Cooling Sound Level (dBA)	Step 1 (dBA)	Step 2 (dBA)
Multi F with LGRED	LMU180HHV	ODU DIP Switch	50	48	45
	LMU240HHV	ODU DIP Switch	52	48	45
	LMU300HHV	ODU DIP Switch	52	48	45
Multi F MAX with LGRED	LMU361HHV	ODU DIP Switch	53	51	47
	LMU421HHV	ODU DIP Switch	54	51	47
	LMU480HHV	ODU DIP Switch	54	51	47

### PCB Display

The cycle data can be checked without using LG Monitoring View (LGMV) Diagnostic Software by pushing TACT-SW1 on some models. See below for the types of cycle information that will be displayed in LGMV. After first page is displayed, the second page will be subsequently displayed.

#### ⚠ WARNING

Protect fingers / hands with a non-conducting material before pushing TACT-SW / TACT-SW1. There is risk of physical injury or death due to electric shock.

Table 41: PCB Display Information.

TACT-SW1 No. of Pushes	Description	Display		
		Example	First Page	Second Page
One (1) Time	Low Pressure	890kpa	"LP"	"89"
Two (2) Times	High Pressure	2,900kpa	"HP"	"290"
Three (3) Times	Discharge Temperature	85°C	"DS"	"85"
Four (4) Times	Condenser Outlet Temperature	-10°C	"CS"	"-10"
Five (5) Times	Suction Temperature	-10°C	"SS"	"-10"
Six (6) Times	Outdoor Unit Air Temperature	-10°C	"AS"	"-10"
Seven (7) Times	Current	15A	"A"	"15"
Eight (8) Times	Voltage	230V	"V"	"230"
Nine (9) Times	Compressor Hz	100Hz	"F"	"100"
Ten (10) Times	DC Link Voltage	230V	"dc"	"230"

Figure 127: Location of TACT-SW1.

LMU180HHV / LMU240HHV / LMU300HHV  
(18 / 24 / 30 kBtu/h)



**Note:**

This PCB does not include a TACT-SW1, however cycle information can be viewed using LGMV.

LMU361HHV / LMU421HHV / LMU480HHV  
(36 / 42 / 48 kBtu/h)

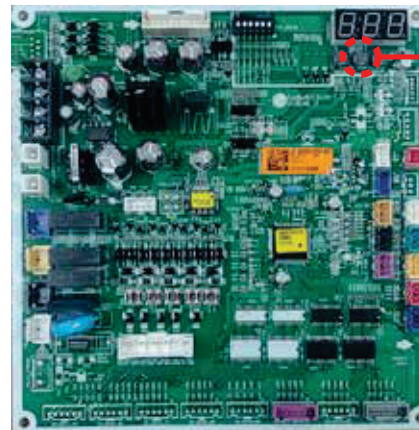

TACT-SW1



**WARNING** Please refer to the Safety Precautions on pages 4-7 for more detail to prevent injury or death regarding the operation and service troubleshooting of the Multi F / Multi F MAX with LGRED product.

## Troubleshooting Using Error Codes

Refer to the tables below and on the next pages for error codes that are generated from the indoor and outdoor units. These codes indicate different types of unit failures, assist in self-diagnosis, and are the most common that will manifest themselves on the LEDs. Error codes are displayed on indoor unit LEDs, wired remote controllers, the outdoor unit PCB, and through LG Monitoring View (LGMV) diagnostic software.

Systems could generate additional codes not listed here. Contact LG Support if these types of errors are seen and a simple power down and boot up has not corrected the issue. ⚠ Do not attempt to fix the system yourself.

- If two or more errors occur simultaneously, the highest error code number is displayed first.
- After the error is corrected, the error code will cease to display without user intervention.

### Decoding the Error Display

See images and table below for indoor unit error codes, location of LEDs, and operation status.

The first and second number on the LED indicates error number. Example: 21 = LED1 (Red light) 2x blink, LED2 (Green light) 1x blink.

### Note:

Appearances will vary depending on model.

Figure 128: Example of Standard Wall-Mounted Indoor Unit LEDs.

#### Standard Wall Mounted

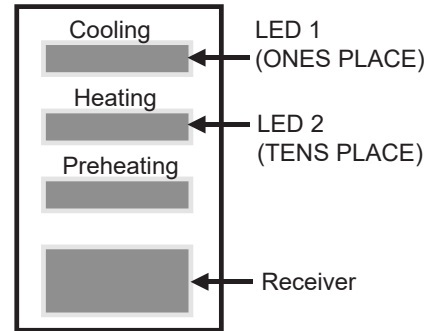

Figure 129: Example of Art Cool Mirror Wall-Mounted Indoor Unit LEDs.

#### Artcool Mirror

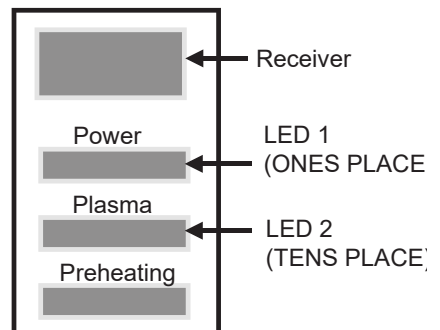

Table 42: Wall-Mounted Indoor Unit Error Codes.

Error Code	Description	Indoor Unit Operation Status
00	No error	ON
01	Indoor unit room temperature sensor error	OFF
02	Indoor unit inlet pipe sensor error	OFF
03	Controller error	OFF
04	Drain pump error (optional)	OFF
05	Communication error between indoor unit and outdoor units	OFF
06	Indoor unit outlet pipe sensor error	OFF
07	Different mode operation error	OFF
09	Indoor unit EEPROM error	OFF
10	Indoor unit BLDC motor fan lock	OFF

# ERROR CODE TABLES

MULTI F WITH LGRED<sup>®</sup>  
MULTI F MAX



**WARNING** Please refer to the Safety Precautions on pages 4-7 for more detail to prevent injury or death regarding the operation and service troubleshooting of the Multi F / Multi F MAX with LGRED product.

## Four-Way Ceiling Cassette Indoor Unit Error Indicator

Figure 130: Ceiling Cassette Display.

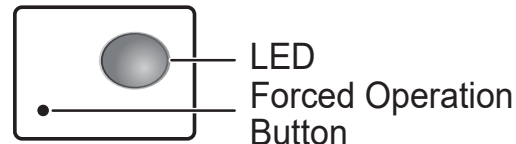

Table 43: Four-Way Ceiling Cassette Indoor Unit LED Indications.

Description	LED Color
Cooling Mode	Green
Heating Mode	Green
Time to Clean Filter (When Unit is Operating In Cooling or Heating Mode)	Yellowish Green
Time to Clean Filter (When Unit Is Not Operating)	Orange
Hot Start or Defrost Mode before Starting Heating Mode	Green
When Reservation Set Is On	Yellowish Green

## Decoding Four-Way Ceiling Cassette Error Codes

- Error codes on the LED flash ON / OFF as presented in the table below.
- If two or more errors occur simultaneously, the highest priority error code is displayed.
- After error is resolved, the error code is simultaneously released and does not display.
- To operate the system again after an error code occurs and has been resolved, cycle the power.
- Error code displays differ depending on model.

Table 44: Four-Way Ceiling Cassette Indoor Unit Error Codes.

Error Code	Description	Cause
1	Indoor unit air temperature sensor error	Indoor unit air temperature sensor is disconnected or shorted.
2	Indoor unit inlet pipe temperature sensor error	Indoor unit inlet pipe temperature sensor is disconnected or shorted.
3	Communication error between wired remote controller and indoor unit	Indoor unit PCB is not receiving communications signal from wired remote controller.
4	Drain pump error.	Drain pump is malfunctioning.
5	Communication error between indoor unit and outdoor unit	Indoor unit communications PCB is not receiving signal from outdoor unit communications PCB.
6	Indoor unit outlet pipe temperature sensor error	Indoor unit outlet pipe temperature sensor is disconnected or shorted.
9	Indoor unit EEPROM error	Serial number on EEPROM of indoor unit is 0 or FFFFFF.
10	Indoor unit fan motor operation error	Fan motor connector has been disconnected. Indoor fan motor lock has failed.



**WARNING** Please refer to the Safety Precautions on pages 4-7 for more detail to prevent injury or death regarding the operation and service troubleshooting of the Multi F / Multi F MAX with LGRED product.

Table 45: Outdoor Unit Error Codes.

Error Code	Description	No. of Times Outdoor Unit LEDs Blink		Outdoor Operation Status
		LED01 (Red)	LED02 (Green)	
21	DC Peak (IPM Fault); Compressor DC voltage is too high	2X	1X	OFF
22	Current Transformer2 (CT2) error; Alternating current (AC) input is too high	2X	2X	OFF
23	DC Link Low Voltage (DC Link Voltage is <140VDC)	2X	3X	OFF
	DC Link High Voltage (DC Link Voltage is >420VDC)			
25	AC Low / High Voltage	2X	5X	OFF
26	DC Compressor Position Error (Compressor failed to start properly)	2X	6X	OFF
27	PSC / PFC Fault; Input current to inverter compressor PCB is too high	2X	7X	OFF
29	Current to inverter compressor is too high	2X	9X	OFF
32	Inverter compressor discharge pipe (D-Pipe) temperature is too high	3X	2X	OFF
35	Low Pressure Error; Pressure dropped below recommended limits	3X	5X	OFF
39	Communication Error between PFC MICOM and Inverter MICOM	3X	9X	OFF
40	CT Sensor Error; Thermistor is open or has short circuited	4X	-	OFF
41	Inverter compressor discharge pipe (D-Pipe) sensor is open or has short circuited	4X	1X	OFF
43	High pressure sensor is open or has short circuited	4X	3X	OFF
44	Outdoor air sensor is open or has short circuited	4X	4X	OFF
45	Mid-pipe thermistor of outdoor unit condenser is open or has short circuited	4X	5X	OFF
46	Outdoor unit suction piping thermistor is open or has short circuited	4X	6X	OFF
48	Outlet piping (liquid) of condenser is open or has short circuited	4X	8X	OFF
51	Combination ratio (capacity) is out of range; Total nominal indoor unit capacity is <50% or >130% of the outdoor unit capacity	5X	1X	OFF
53	Communication failure between outdoor unit and indoor unit(s)	5X	3X	OFF
54	Outdoor unit is not wired properly (ex: reversed phase)	5X	4X	OFF
60	Outdoor unit printed circuit board (PCB) EEPROM check sum error	6X	-	OFF
61	Condenser coil thermistor temperature is too high	6X	1X	OFF
62	Outdoor unit inverter compressor PCB heat sink temperature is too high	6X	2X	OFF
65	Heat sink thermistor is open or has short circuited	6X	5X	OFF
67	Outdoor unit brushless direct current (BLDC) fan motor lock error	6X	7X	OFF
73	Outdoor unit PFC overcurrent (peak) error	7X	3X	OFF

# LG MONITORING VIEW (LGMV) DIAGNOSTIC SOFTWARE

MULTI F WITH LGRED<sup>®</sup>  
MULTI F MAX

## LG Monitoring View (LGMV) Diagnostic Software

LG Monitoring View (LGMV) software allows the service technician or commissioning agent to connect a computer USB port to the Multi F / Multi F MAX with LGRED system's main printed circuit board (PCB) using an accessory cable without the need for a separate interface device.

LGMV is available in different formats, including Mobile LGMV, which is an app for use on wireless devices. Contact your LG Sales Representative for more information, including recommended PC or mobile device configurations.

Figure 131: LGMV Monitoring Screen.



### Note:

- Images on these pages are examples of LGMV screenshots. Actual images will differ depending on the version of the software and the units installed.
- Information displayed also depends on which unit is installed.

### LGMV Display

LGMV displays the following real-time data:

- Actual inverter compressor speed
- Target inverter compressor speed
- Actual outdoor fan speed
- Target outdoor unit fan speed
- Actual superheat
- Target superheat
- Actual subcooler circuit superheat
- Target subcooler circuit superheat
- Main EEV position
- Subcooling EEV position
- Inverter compressor current transducer value
- Outdoor air temperature
- Actual high pressure/saturation temperature
- Actual low pressure/saturation temperature
- Suction temperature
- Inverter compressor discharge temperature
- Constant speed compressor discharge temperature
- Front outdoor coil pipe temperature
- Back outdoor coil pipe temperature
- Liquid line pipe temperature
- Subcooler inlet temperature
- Subcooler outlet temperature
- Average indoor unit (IDU) pipe temperature
- Inverter compressor operation indicator light
- Four-way reversing valve operation indicator light
- Pressure graph showing actual low pressure and actual high pressure levels
- Error code display
- Operating mode indicator
- Target high pressure
- Target low pressure
- PCB (printed circuit board) version
- Software version
- Installer name
- Model no. of outdoor units
- Site name
- Total number of connected indoor units
- Communication indicator lights
- Indoor unit capacity
- Indoor unit operating mode
- Indoor unit fan speed
- Indoor unit EEV position
- Indoor unit room temperature
- Indoor unit inlet pipe temperature
- Indoor unit outlet pipe temperature
- Indoor unit error code

Additional screens can be accessed by tabs on the main screen. Additional screens include:

1. Cycleview: Graphical display of internal components including:
  - Compressors showing actual speeds
  - EEVs
  - Indoor units
  - Liquid injection valves
  - Temperature and pressure sensors
  - Four-way reversing valve
  - Outdoor fans showing status and speeds
2. Graph: Full screen graph of actual high and low pressures and high and low pressure limits. A sliding bar allows viewing of previously recorded data.
3. Control IDU: Enables user to turn on IDUs with default setpoints of 86°F in heating mode or 64°F in cooling mode.
4. Setting: Converts metric values to imperial values.
5. Making Data: Recording of real time data to a separate file created to be stored on the user's computer.
6. Loading Data: Recorded data from a saved ".CSV" file can be loaded to create an LGMV session.
7. Electrical Data: The Electric tab on the main screen is changed to show the following:
  - Inverter compressor
    - Amps
    - Volts
    - Power Hz
    - Inverter control board fan Hz
  - Constant compressor
    - Current transducer value
    - Phase

Figure 133: LGMV Cycleview Screen.

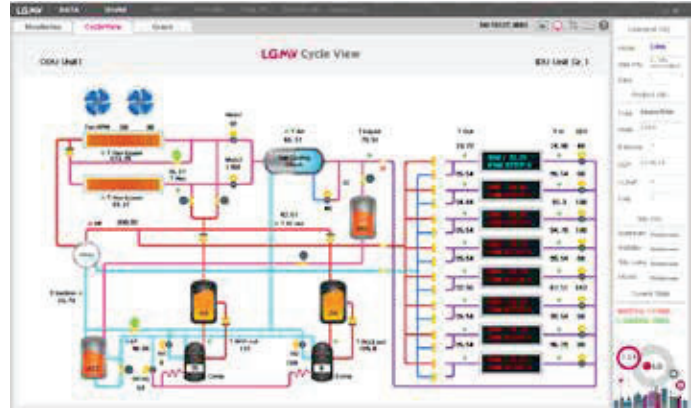
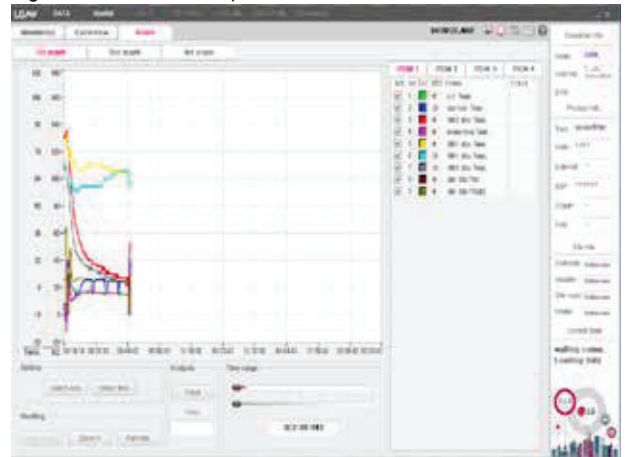

Figure 132: LGMV Graph Screen.



### Note:

- Images on these pages are examples of LGMV screenshots. Actual images will differ depending on the version of the software and the units installed.
- Information displayed also depends on which unit is installed.

# MAINTENANCE RECOMMENDATIONS

MULTI F WITH LGRED°  
MULTI F MAX

Table 46: Maintenance Recommendations.

Component	Maintenance	Occurrence (Minimum)
Indoor Units	Wash filters	On a regular basis / as needed
	Clean coils	Once a year
	Clean / check unit base pan	Once a year
Outdoor Unit(s)	Clean coils	Once or twice a year
Communications Cable and Power Wiring	Verify that all cables and wiring are properly connected	Once or twice a year

**Note:**

*It is also recommended to monitor system operation using LGMV and / or SIMS Software at least once a year.*



# INSTALLATION CHECKLIST

PAGE 1

## Major Component Rough-In

Description	Check
Multi F / Multi F MAX with LGRED outdoor unit was connected properly per local code and the product installation procedures.	
All literature and bagged accessories have been removed from the fan discharge vicinity (ducted and cassette model indoor units).	
All indoor units and branch distribution unit(s) (Multi F MAX with LGRED only) are installed, properly supported, and located indoors in a non-corrosive environment.	
Duct work installation has been completed per product installation procedures (ducted indoor units only).	

## Piping Material, Components, and Insulation

Description	Check
Multi-zone duct-free split systems: ACR copper piping rated at the system working pressure was used.	
LG Y-branch fitting was used per manufacturer's recommendations (Multi F MAX with LGRED only).	
All refrigerant pipes and valves were insulated separately. Insulation is positioned up against the walls of the indoor units and branch distribution units (Multi F MAX with LGRED only). No gaps shown. Insulation was not compressed at clamps and hangers.	

## Brazing Practices

Description	Check
Use medical grade dry nitrogen for purging during brazing (constant 3 psig while brazing).	
15% silver brazing material only.	

## Refrigerant Piping Design and System

Description	Check
You must have in your possession a copy of the "As-Designed" LATS Multi V piping tree diagram. BEFORE ANY FIELD PIPE SIZE OR LENGTH CHANGES ARE MADE, PROPOSED CHANGES MUST BE FORWARDED TO THE DESIGN ENGINEER SO THAT THEY CAN INPUT THE CHANGES INTO LATS and RE-ISSUE A NEW LATS MULTI V PIPING TREE DIAGRAM. Installer must receive change authorization from the design engineer, because any change made requires the review of the entire tree diagram and verification that the change did not impact the size of piping segments in other parts of the system.	
All pipe materials were properly stored, capped, and clean. All burrs were removed after cutting and pipe ends were reamed before brazing.	
During refrigerant pipe installation, for each segment of pipe, a record was made of the pipe length (including expansion loops, offsets, double-back sections), and sizes, as well as the quantity and type of elbows used.	
Expansion loops, coils or other acceptable measures are provided where necessary to absorb temperature-change based pipe movement.	
A torque wrench and backup wrench were used to tighten all flare connections.	
The back side of all flares were lubricated with a small drop of PVE refrigeration oil before tightening flare fittings.	
Ensure all field made flares are 45°. Use factory-supplied flare nuts only.	
Pipe segments and Y-branch fittings are secured to the structure using a combination of fixed and floating clamps, and all wall penetrations were sleeved.	
Pipe insulation was not compressed at any point.	
Y-branch fittings were properly INSTALLED per details provided in the Multi F / Multi F MAX with LGRED Outdoor Unit Installation Manual.	
Y-branch fittings were properly SUPPORTED per details provided in the Multi F / Multi F MAX with LGRED Outdoor Unit Installation Manual.	
No oil traps, solenoid valves, sight glasses, filter driers, or any other unauthorized refrigerant specialties were present.	
(Optional) High quality R-410A rated full port ball valves (Schrader between the valve body and the indoor units) used at all indoor units and at will in the refrigerant piping network.	



# INSTALLATION CHECKLIST

PAGE 2

## Condensate Pump / Drain Installation

Description	Check
Condensate piping is installed correctly on indoor units. Material used is acceptable under local code. Insulated as necessary to prevent condensation.	
All condensate vertical risers are equal to or less than 27-1/2 inches from the bottom of the indoor unit.	
Indoor units with condensate pumps are level. Units with gravity drains are level or slightly canted toward the drain connection and are supported properly.	
Pumped condensate drain lines are properly connected (⊖ do not have traps, and connect to the top surface of the main drain line).	
Multi F / Multi F MAX with LGRED gravity condensate drain line is connected and routed where it properly drains away or, if installed in a mechanical room, was connected and properly routed to a drain connection.	
All condensate lines are properly insulated to prevent condensation.	

## Power Wire and Communications Cables

Description	Check
Ground wire is installed and properly terminated at the unit.	
Power wiring is connected to a single phase 208-230V source.	
The power supplied is clean with voltage fluctuations within specifications ( $\pm 10\%$ of nameplate).	
Power wiring to the Multi F / Multi F MAX with LGRED outdoor unit is field supplied, solid or stranded, and installed per all local, state, and NEC requirements.	
For Multi F with LGRED Systems <ul style="list-style-type: none"> <li>• Communication / connection (power) wiring from the outdoor unit to the indoor unit is minimum 14 gauge, four-conductor, stranded, shielded or unshielded. If shielded, must be grounded to chassis at the outdoor unit only.</li> <li>• Use of 14 AWG, four (4) conductor, stranded, shielded or unshielded wire is allowed for lengths up to the published maximum pipe length, plus recommended slack at both ends.</li> </ul>	
For Multi F MAX with LGRED Systems <p>All power wiring / communication cable to be minimum 14 AWG from the Multi F MAX with LGRED outdoor unit to the BD unit stranded, shielded or unshielded (if shielded, it must be grounded to the chassis of the outdoor unit only), and must comply with applicable local and national codes.</p> <ul style="list-style-type: none"> <li>• Communication / connection (power) wiring from the BD unit to the indoor unit is minimum 14 gauge, four-conductor, stranded, shielded or unshielded. If shielded, must be grounded to chassis at the BD unit only.</li> <li>• Use of 14 AWG, four (4) conductor, stranded, shielded or unshielded wire is allowed for lengths up to the published maximum pipe length, plus recommended slack at both ends.</li> </ul>	
Power wiring to the outdoor unit and communication / connection (power) cable from the outdoor unit to the indoor units or branch distribution units (Multi F MAX with LGRED only) are separated per manufacturer's guidelines. These cannot be run in the same conduit.	
Communications / connection (power) cable were not ran in the same conduit (outdoor unit to indoor unit or branch distribution unit (Multi F MAX with LGRED only) as provided in the product installation manual.	
Proper communications cable was used between each indoor unit and its zone controller where applicable. Cables are continuous with no splices between terminals.	
Communication type RS-485-BUS type.	
Used appropriate crimping tool to attach ring or fork terminals at all power wiring and control cable terminations.	
Only LG-supplied Y-cables are used between grouped indoor units, if applicable.	



# INSTALLATION CHECKLIST

PAGE 3

## Major Component Rough-In

## Piping and Insulation

## Brazing Practices



# INSTALLATION CHECKLIST

PAGE 4

## Installation—Refrigerant Piping

## Installation—Branch Distribution Unit (Multi F MAX with LGRED Systems Only)

## Installation—Condensate Pump / Drain Installation

## Installation—Power Wire and Communications Cables



# MULTI F WITH LGRED REFRIGERANT CHARGE WORKSHEET

LG Multi F with LGRED outdoor units ship from the factory with a charge of R410A refrigerant. A trim charge may need to be added to take into account additional piping length.

To determine the additional refrigerant that is needed, apply the formula below, and record the results. If the total additional refrigerant charge value is a negative number, then an additional trim charge does not need to be added to the system.

### Multi F with LGRED Outdoor Unit Factory Charge

Outdoor Unit	Factory Charge oz. of R410A
LMU180HHV	98.8
LMU240HHV	112.8
LMU300HHV	112.8

### Multi F with LGRED Outdoor Unit Additional Refrigerant Charge Formula

$$\begin{aligned} \text{Additional charge (lbs.)} = & (\text{Installed Length of Branch [A]} - \text{Chargeless Pipe Length [L]}) \times a \\ & + (\text{Installed Length of Branch [B]} - \text{Chargeless Pipe Length [L]}) \times a \\ & + (\text{Installed Length of Branch [C]} - \text{Chargeless Pipe Length [L]}) \times a \\ & + (\text{Installed Length of Branch [D]} - \text{Chargeless Pipe Length [L]}) \times a \\ & - \text{CF (Correction Factor)} \times 5.29 \end{aligned}$$

### Note:

- Number of installed length of branches depends on the specifications of the outdoor unit model.
- CF = Maximum number of connectible indoor units – Total number of connected indoor units.

### Multi F with LGRED Outdoor Unit Piping Specifications

Multi F Outdoor Unit Model	Min. to Max. Piping Length for One Branch (ft.)	Max. Total System Piping Length (ft.)	Chargeless Pipe Length per Branch (L) (ft.)	Additional Charge Needed (a) (oz./ft.)
LMU180HHV	9.8 to 82	164	24.6	0.22
LMU240HHV	9.8 to 82	246.1	24.6	0.22
LMU300HHV	9.8 to 82	246.1	24.6	0.22

### Multi F with LGRED Refrigerant Charge Calculations

$$\begin{aligned} & (\text{_____ [A]} - 24.6) \times 0.22 && (\text{_____}) \\ + & (\text{_____ [B]} - 24.6) \times 0.22 && + (\text{_____}) \\ + & (\text{_____ [C]} - 24.6) \times 0.22 && + (\text{_____}) \\ + & (\text{_____ [D]} - 24.6) \times 0.22 && + (\text{_____}) \\ - & \text{_____ CF} \times 5.29 && - (\text{_____}) \\ = & \text{_____ Additional Charge (oz.)} \end{aligned}$$



# MULTI F MAX WITH LGRED REFRIGERANT CHARGE WORKSHEET

LG Multi F MAX with LGRED outdoor units ship from the factory with a charge of R410A refrigerant. A trim charge may need to be added to take into account additional piping length.

To determine the additional refrigerant that is needed, apply the formula below, and record the results. If the total additional refrigerant charge value is a negative number, then an additional trim charge does not need to be added to the system.

## Multi F MAX with LGRED Outdoor Unit Factory Charge

Outdoor Unit	Factory Charge oz. of R410A
LMU361HHV	183.4
LMU421HHV	183.4
LMU480HHV	183.4

$$\begin{aligned} \text{Additional charge (lbs.)} &= (\text{Total Main Piping Length [A]} - \text{Chargeless Pipe Length of Main Pipe [L]}) \times a \\ &+ (\text{Total Installed Length of Branch [B1+B2+B3...]} - \text{Chargeless Branch Length [B]}) \times b \\ &- \text{CF (Correction Factor)} \times 3.53 \end{aligned}$$

### Note:

- Number of installed length of branches depends on system specifications.
- CF = Maximum number of connectible indoor units – Total number of connected indoor units

## Multi F MAX with LGRED Outdoor Unit Piping Specifications

Outdoor Unit Model	Main Piping Length		Branch Piping Length	
	Chargeless Pipe Length of Main Pipe (L) (ft.)	Additional Charge Needed (a) (oz./ft.)	Chargeless Pipe Length of Branch Pipe (ΣB) (ft.)	Additional Charge Needed (b) (oz./ft.)
LMU361HHV	49.2	0.54	131.2	0.22
LMU421HHV	49.2	0.54	131.2	0.22
LMU480HHV	49.2	0.54	131.2	0.22

## Multi F MAX with LGRED Refrigerant Charge Calculations

$$\begin{aligned} &(\text{_____} [A] - 49.2) \times 0.54 && (\text{_____}) \\ + &(\text{_____} [B1+B2+B3...] - 131.2) \times 0.22 && + (\text{_____}) \\ - &\text{_____} \text{CF} \times 3.53 && - (\text{_____}) \\ &&& = \text{_____} \text{ Additional Charge (oz.)} \end{aligned}$$

*Inverter*

162279



LG Electronics, U.S.A., Inc.  
Air Conditioning Technologies  
4300 North Point Parkway  
Alpharetta, Georgia 30022  
www.lghvac.com

IM\_MultiF\_MAX\_LGRED\_ODU\_1HHV\_480HHV\_01\_22  
Supersedes: IM\_MultiF\_MAX\_LGRED\_ODU\_1HHV\_480HHV\_11\_21  
IM\_MultiF\_MAX\_LGRED\_ODU\_11\_20  
IM\_MultiF\_MAX\_LGRED\_ODU\_09\_20  
IM\_MultiF\_MAX\_LGRED\_ODU\_06\_20  
IM\_MultiF\_MAX\_LGRED\_ODU\_04\_20  
IM\_MultiF\_MAX\_LGRED\_ODU\_05\_18



# MULTI F

# MULTI F MAX

## CEILING CASSETTE INDOOR UNIT INSTALLATION MANUAL



- LMCN077HV 7 kBtu
- LCN097HV4 9 kBtu
- LCN127HV4 12 kBtu
- LMCN185HV 18 kBtu

# PROPRIETARY DATA NOTICE

This document, as well as all reports, illustrations, data, information, and other materials are the property of LG Electronics U.S.A., Inc., and are disclosed by LG Electronics U.S.A., Inc., only in confidence.

*Do not throw away, destroy, or lose this manual.*

Please read carefully and store in a safe place for future reference.  
Content familiarity required for proper installation.

*The instructions included in this manual must be followed to prevent product malfunction, property damage, injury, or death to the user or other people. Incorrect operation due to ignoring any instructions will cause harm or damage. A summary of safety precautions begins on page 4.*

*For more technical materials such as submittals, engineering databooks, and catalogs, visit [www.lghvac.com](http://www.lghvac.com).*

IM\_Multi\_F\_CeilingCassette\_7\_16

For continual product development, LG Electronics U.S.A., Inc., reserves the right to change specifications without notice.

©LG Electronics U.S.A., Inc.

*This document, as well as all reports, illustrations, data, information, and other materials are the property of LG Electronics U.S.A., Inc.*

**CONTENTS**

Safety Instructions ..... 4

Introduction ..... 9

Unit Nomenclature ..... 11

General Data ..... 12

*Specifications* ..... 13

*Typical Multi F / Multi F Max Systems* ..... 15

*Refrigerant Piping Requirements* ..... 17

General Installation Guidelines..... 18

*Location Selection* ..... 18

*Inspection* ..... 19

*Install Ceiling Cassette* ..... 20

*Installing Drain System*..... 22

*Refrigerant Piping*..... 23

*Piping Materials and Handling*..... 31

Piping Connections..... 32

*Piping Preparation* ..... 32

*IDU to ODU* ..... 33

*Piping Insulation* ..... 36

Electrical Wiring..... 38

*General Guidelines*..... 38

*Power Wiring Specifications and Best Practices* ..... 39

*Controller Options*..... 40

*Power Wiring / Communications Cable Installation Guidelines* ..... 40

*Indoor Unit Electrical Connections Procedure*..... 41

*Decorative Grille Kit Installation*..... 43

*Self Diagnosis Functions* ..... 44

*LG SIMS - Self Diagnosis Functions* ..... 46

*Controller Options*..... 48

Troubleshooting ..... 51

*Error Codes* ..... 51

Cautions for Refrigerant leaks ..... 53

*Refrigerant Leaks* ..... 53

Installation Checklist..... 54

Pre-Commissioning Checklist..... 58

Commissioning Notes..... 62





Commissioning Checklist Exception Report..... 63

Multi F Refrigerant Charge Worksheet ..... 64

Multi F MAX Refrigerant Charge Worksheet ..... 65

The instructions below must be followed to prevent product malfunction, property damage, injury or death to the user or other people. Incorrect operation due to ignoring any instructions will cause harm or damage. The level of seriousness is classified by the symbols described below.

## TABLE OF SYMBOLS

 <b>DANGER</b>	<i>This symbol indicates an imminently hazardous situation which, if not avoided, will result in death or serious injury.</i>
 <b>WARNING</b>	<i>This symbol indicates a potentially hazardous situation which, if not avoided, could result in death or serious injury.</i>
 <b>CAUTION</b>	<i>This symbol indicates a potentially hazardous situation which, if not avoided, may result in minor or moderate injury.</i>
<b>Note</b>	<i>This symbol indicates situations that may result in equipment or property damage accidents only.</i>
	<i>This symbol indicates an action should not be completed.</i>

## Installation

### DANGER

 **Do not store or use flammable gas or combustibles near the unit.**

*There is risk of fire, explosion, and physical injury or death.*

 **Do not supply power to the unit until all wiring and piping are completed or reconnected and checked.**

*There is risk of physical injury or death due to electric shock.*

### WARNING

 **Do not install, remove, or re-install the unit by yourself (end-user). Ask the dealer or a trained technician to install the unit.**

*Improper installation by the user may result in water leakage, fire, explosion, electric shock, physical injury or death.*

**Always check for system refrigerant leaks after the unit has been installed or serviced.**

*Exposure to high concentration levels of refrigerant gas may lead to illness or death.*

 **Do not install the unit using defective hanging, attaching, or mounting hardware.**

*There is risk of physical injury or death.*

**For replacement of an installed unit, always contact an LG trained service provider.**

*There is risk of fire, electric shock, explosion, and physical injury or death.*



**Dispose of the packing materials safely.**

- *Packing materials, such as nails and other metal or wooden parts may cause puncture wounds or other injuries.*

- *Tear apart and throw away plastic packaging bags so that children may not play with them and risk suffocation and death.*

**The outdoor unit is shipped with refrigerant and the service valves closed.  Do not open service valves on the unit until all non-condensibles have been removed from the piping system and authorization has been obtained from the commissioning agent.**

*There is a risk of physical injury or death.*

 **Do not install the unit in any location exposed to open flame or extreme heat.  Do not touch the unit with wet hands.**

*There is risk of fire, electric shock, explosion, and physical injury or death.*

 **Do not run the compressor with the service valves closed.**

*There is risk of explosion, physical injury, or death.*

**Periodically check that the outdoor unit is not damaged.**

*There is risk of explosion, physical injury, or death.*

**Install the unit considering the potential for earthquakes.**

*Improper installation may cause the unit to fall, resulting in physical injury or death.*

**Replace all control box and panel covers.**

*If cover panels are not installed securely, dust, water and animals may enter the unit, causing fire, electric shock, and physical injury or death.*

 **Do not change the settings of the protection devices.**

*If the pressure switch, thermal switch, or other protection device shorted and forced to operate improperly, or parts other than those specified by LG are used, there is risk of fire, electric shock, explosion, and physical injury or death.*

**Wear protective gloves when handling equipment.**

*Sharp edges may cause personal injury.*

---

---

## Installation, continued

### ⚠ WARNING

If the air conditioner is installed in a small space, take measures to prevent the refrigerant concentration from exceeding safety limits in the event of a refrigerant leak.

Consult the latest edition of ASHRAE (American Society of Heating, Refrigerating, and Air Conditioning Engineers) Standard 15. If the refrigerant leaks and safety limits are exceeded, it could result in personal injuries or death from oxygen depletion.

**Properly insulate all cold surfaces to prevent “sweating.”**

*Cold surfaces such as uninsulated piping can generate condensate that could drip, causing a slippery surface that creates a risk of slipping, falling, and personal injury.*

---

### ⚠ CAUTION

**Be very careful when transporting the product.**

- Ⓞ Do not attempt to carry the product without assistance.
- Some products use polypropylene bands for packaging. Ⓞ Do not use polypropylene bands to lift the unit.
- Suspend the unit from the base at specified positions.
- Support the unit at a minimum of four points to avoid slippage from rigging apparatus.
- Failure to follow these directions may result in minor or moderate physical injury.

---

### Note:

LG Electronics U.S.A., Inc., is not responsible for any piping calculations, refrigerant leaks, degradation of performance, or any other potential problems or damages as a result of interconnecting piping, their joint connections, isolation valves, introduced debris inside the piping system, or other problems caused by the interconnecting piping system.

**Properly insulate all cold surfaces to prevent “sweating.”**

*Cold surfaces such as uninsulated pipe can generate condensate that may drip and cause water damage to walls.*

**When installing the unit in a hospital, mechanical room, or similar electromagnetic field (EMF) sensitive environment, provide sufficient protection against electrical noise.**

*Inverter equipment, power generators, high-frequency medical equipment, or radio communication equipment may cause the air conditioner to operate improperly. The unit may also affect such equipment by creating electrical noise that disturbs medical treatment or image broadcasting.*

Ⓞ **Do not use the product for special purposes such as preserving foods, works of art, wine coolers, or other precision air conditioning applications. This equipment is designed to provide comfort cooling and heating.**

*There is risk of property damage.*

Ⓞ **Do not make refrigerant substitutions. Use R410A only.**

*If a different refrigerant is used, or air mixes with original refrigerant, the unit will malfunction and be damaged.*

Ⓞ **Do not install the unit in a noise sensitive area.**

**When connecting refrigerant tubing, remember to allow for pipe expansion.**

*Improper piping may cause refrigerant leaks and system malfunction.*

**Periodically check that the unit is not damaged.**

*There is a risk of equipment damage.*

**Take appropriate actions at the end of HVAC equipment life to recover, recycle, reclaim or destroy R410A refrigerant according to applicable U.S. Environmental Protection Agency (EPA) rules.**

**Install the unit in a safe location where no one can step on or fall onto it. Ⓞ Do not install the unit with defective hanging, attaching, or mounting hardware.**

*There is risk of unit and property damage.*

**Install the drain hose to ensure adequate drainage.**

*There is a risk of water leakage and property damage.*

Ⓞ **Don't store or use flammable gas / combustibles near the unit.**

*There is risk of product failure.*

**Always check for system refrigerant leaks after the unit has been installed or serviced.**

*Low refrigerant levels may cause product failure.*

**The unit is shipped with refrigerant and the service valves closed. Ⓞ Do not open service valves on the unit until all non-condensibles have been removed from the piping system and authorization to do so has been obtained from the commissioning agent.**

*There is a risk of refrigerant contamination, refrigerant loss and equipment damage.*

## Wiring

### ⚠ DANGER

**High voltage electricity is required to operate this system. Adhere to the NEC code and these instructions when wiring.**  
*Improper connections and inadequate grounding can cause accidental injury or death.*

**Always ground the unit following local, state, and NEC codes.**  
*There is risk of fire, electric shock, and physical injury or death.*

**Turn the power off at the nearest disconnect before servicing the equipment.**  
*Electric shock can cause physical injury or death.*

**Properly size all circuit breakers or fuses.**  
*There is risk of fire, electric shock, explosion, physical injury or death.*

⊘ **Do not use damaged or loose power wiring.** ⊘ **Do not modify or extend the outdoor unit's power wiring randomly. Ensure that the power wiring will not be pulled nor weight be placed on the power wiring during operation.**  
*There is risk of fire, electric shock, and physical injury or death.*

### ⚠ WARNING

**The information contained in this manual is intended for use by an industry-qualified, experienced, trained electrician familiar with the U.S. National Electric Code (NEC) who is equipped with the proper tools and test instruments.**  
*Failure to carefully read and follow all instructions in this manual can result in equipment malfunction, property damage, personal injury or death.*

**All electric work must be performed by a licensed electrician and conform to local building codes or, in the absence of local codes, with the National Electrical Code, and the instructions given in this manual.**  
*If the power source capacity is inadequate or the electric work is not performed properly, it may result in fire, electric shock, physical injury or death.*

**Ensure the system is connected to a dedicated power source that provides adequate power.**  
*If the power source capacity is inadequate or the electric work is not performed properly, it may result in fire, electric shock, physical injury or death.*

**Refer to local, state, and federal codes, and use power wires of sufficient current capacity and rating.**  
*Wires that are too small may generate heat and cause a fire.*

**Secure all field wiring connections with appropriate wire strain relief.**  
*Improperly securing wires will create undue stress on equipment power lugs. Inadequate connections may generate heat, cause a fire and physical injury or death.*

**Properly tighten all power connections.**  
*Loose wiring may overheat at connection points, causing a fire, physical injury or death.*

⊘ **Do not change the settings of the protection devices.**  
*If the protection devices have been bypassed or are forced to operate improperly, or parts other than those specified by LG are used, there is risk of fire, electric shock, explosion, and physical injury or death.*

### Note:

⊘ **Do not cut, lengthen or shorten the communications and power cable between any dry contact unit and its connected indoor unit. Do not install the unit in a location where the communications and power cable cannot be safely and easily connected between the two units.** ⊘ **Do not allow strain on this cable.**  
*Poor cable connections can cause equipment malfunction.*

⊘ **Do not supply power to the unit until all electrical wiring, controls wiring, piping, installation, and refrigerant system evacuation are completed.**  
*System may malfunction.*

---

---

## Operation

### **⚠ DANGER**

- ⊘ Do not provide power to or operate the unit if it is flooded or submerged.

*There is risk of fire, electric shock, physical injury or death.*

### **Use a dedicated power source for this system.**

*There is risk of fire, electric shock, physical injury or death.*

- ⊘ Do not operate the disconnect switch with wet hands.

*There is risk of fire, electric shock, physical injury or death.*

### **Periodically verify the hanging bolts and other hardware securing the unit have not deteriorated.**

*If the unit falls from its installed location, it can cause physical injury or death.*

---

### **⚠ WARNING**

- ⊘ Do not allow water, dirt, or animals to enter the unit.

*There is risk of unit failure, fire, electric shock, physical injury or death.*

### **Avoid excessive cooling and periodically perform ventilation to the unit.**

*Inadequate ventilation is a health hazard.*

- ⊘ Do not touch the refrigerant piping during or after operation.

*It can cause burns or frostbite.*

- ⊘ Do not operate the unit with the panel(s) or protective cover(s) removed; keep fingers and clothing away from moving parts.

*The rotating, hot, cold, and high-voltage parts of the unit can cause physical injury or death.*

### **Periodically check power cable and connection for damage.**

*Cable must be replaced by the manufacturer, its service agent, or similar qualified persons in order to avoid physical injury and/or electric shock.*

---

### **⚠ CAUTION**

**To avoid physical injury, use caution when cleaning or servicing the air conditioner.**

**Use inert (nitrogen) gas when performing leak tests or air purges.** ⊘ Do not use compressed air, oxygen, or flammable gases.

*Using these substances may cause fire, explosion, and physical injury or death.*

### **If refrigerant gas leaks out, ventilate the area before operating the unit.**

*If the unit is mounted in an enclosed, low-lying, or poorly ventilated area and the system develops a refrigerant leak, it may cause fire, electric shock, explosion, physical injury or death.*

**Ensure no power is connected to the unit other than as directed in this manual. Remove power from the unit before removing or servicing the unit.**

*There is risk of unit failure, fire, electric shock, physical injury or death.*

- ⊘ Do not open the inlet grille of the unit during operation.
- ⊘ Do not operate the unit with the panels or guards removed.
- ⊘ Do not insert hands or other objects through the inlet or outlet when the unit is plugged in.
- ⊘ Do not touch the electrostatic filter, if the unit includes one.

*The unit contains sharp, rotating, hot, and high voltage parts that can cause personal injury and/or electric shock.*

### **Securely attach the electrical cover to the unit.**

*Non-secured electrical covers can result in burns or electric shock due to dust or water in the service panel.*

## Operation, continued

### Note:

Clean up the site after installation is finished, and check that no metal scraps, screws, or bits of wiring have been left inside or surrounding the unit.

⊘ Do not use this equipment in mission critical or special-purpose applications such as preserving foods, works of art, wine coolers or refrigeration. This equipment is designed to provide comfort cooling and heating.

Oil, steam, sulfuric smoke, etc., can significantly reduce the performance of the unit, or damage its parts.

⊘ Do not block the inlet or outlet.  
*Unit may malfunction.*

⊘ Do not open the inlet during operation.  
*There is risk of unit failure.*

**Provide power to outdoor unit to warm the compressor crankcase at least six (6) hours before operation begins.**

*Starting operation with a cold compressor sump(s) may result in severe bearing damage to the compressor(s). Keep the power switch on during the operational season.*

**Periodically verify the hanging bolts and other hardware securing the unit have not deteriorated.**

*If the unit falls from its installed location, it can cause property damage or product failure.*

⊘ Do not operate the unit with the panel(s) or protective cover(s) removed; keep fingers and clothing away from moving parts.

*Non-secured covers can result in malfunction due to dust or water in the service panel.*

⊘ Do not allow water, dirt, or animals to enter the unit.  
*There is risk of unit failure.*

**Use a only soft cloth to clean the air conditioner. ⊘ Do not use wax, thinner, or strong detergents.**

*Strong cleaning products may damage the surface of the air conditioner, or may cause its appearance to deteriorate.*

## Multi F and Multi F MAX Ceiling Cassette Units

This manual describes how to install the LG Multi F and Multi F MAX (Multi Zone) Ceiling Cassette Indoor Units (IDU) for Multi F heat pump systems. Table 1 lists the available models. Refer to LG's Multi F Indoor Unit Engineering Manual for complete detailed engineering data and selection procedures.

### Safety

Safety of personnel is the primary concern during all procedures. Read and understand the safety summary at the front of this manual. Read and understand this installation procedure before beginning installation. Use the appropriate tools and accessories during installation. Plan your work and do not work alone, if possible. Know how to obtain emergency medical and fire fighting assistance.

#### Installation Personnel

This equipment is intended for installation by personnel trained in the required construction, mechanical, electrical, and/or other disciplines.

#### Applicable Codes

Personnel must be familiar with and follow the applicable national, state, and / or local codes. In the event of a conflict between any applicable code and the instructions in this manual, comply with the applicable code.

### ⚠ WARNING

*Installation work must be performed by trained personnel and in accordance with national wiring standards and all local or other applicable codes. Improper installation can result in fire, electric shock, physical injury, or death.*

#### Note:

*Please read all instructions before installing this product. Become familiar with the unit, its components and connections, and the order of installation. Incorrect installation can degrade or prevent proper operation.*

## Factory Supplied Materials

- Installation Guide (template)
- Owner's Manual
- Installation Manual

## Required Tools (field provided)

- |                             |                     |                     |
|-----------------------------|---------------------|---------------------|
| • Level                     | • Flaring tool set  | • Hexagonal wrench  |
| • Screwdriver               | • Tubing cutter     | • Gas-leak detector |
| • Electrical lineman pliers | • Tube/pipe reamer  | • Gauge manifold    |
| • Electric drill            | • Torque wrenches   | • Thermometer       |
| • Hole core drill           | • Adjustable wrench |                     |

## Required Parts (field provided)

- |   |   |  |
|---|---|--|
| • Connecting cable (power and control)                | • 3/8" or 1/2" Threaded hanger rods                       | • Additional drain hose                |
| • Pipes - vapor line and liquid line, with insulation | • 3/8" or 1/2" nuts, flat washers, and lock/split washers | • Insulation for additional drain hose |

Figure 1: Typical Multi F Ceiling Cassette Indoor Unit



Table 1: Multi F Ceiling Cassette Indoor Units.





Typical Unit	Model Number	Nominal Capacity	
		Cooling (Btu)	Heating (Btu)
	LMCN077HV	7,000	8,100
	LCN097HV4	9,000	10,400
	LCN127HV4	12,000	13,800
	LMCN185HV	18,000	20,800

Table 2: Included Items.

Part	Quantity	Image	Part	Quantity	Image
Drain Hose	One (1)		Cable Ties	Four (4)	
Metal Clamp	Two (2)		Conduit Bracket	One (1)	
Insulation for Fittings	One (1) Set	 For Vapor Piping For Liquid Piping	M4 Screws	Two (2)	
Washers for Hanging Bracket	Eight (8)		Wireless Handheld Controller with Holder (AKB73757604) <sup>1</sup>	One (1)	

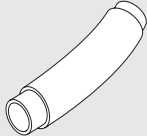
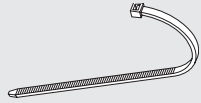
<sup>1</sup>Wireless Handheld Controller for the four-way ceiling cassette indoor units is also referenced by Model No. PQWRHQ0FDB.

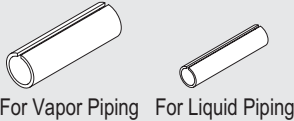
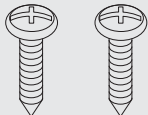
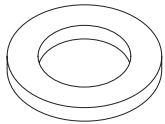
Table 3: Required Accessory Table.

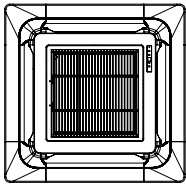
Part	Quantity	Image
Grille Kit (PT-QCHW0 or PT-UQC)	One (1)	

**Multi F Multi-Zone Systems — Indoor Units**

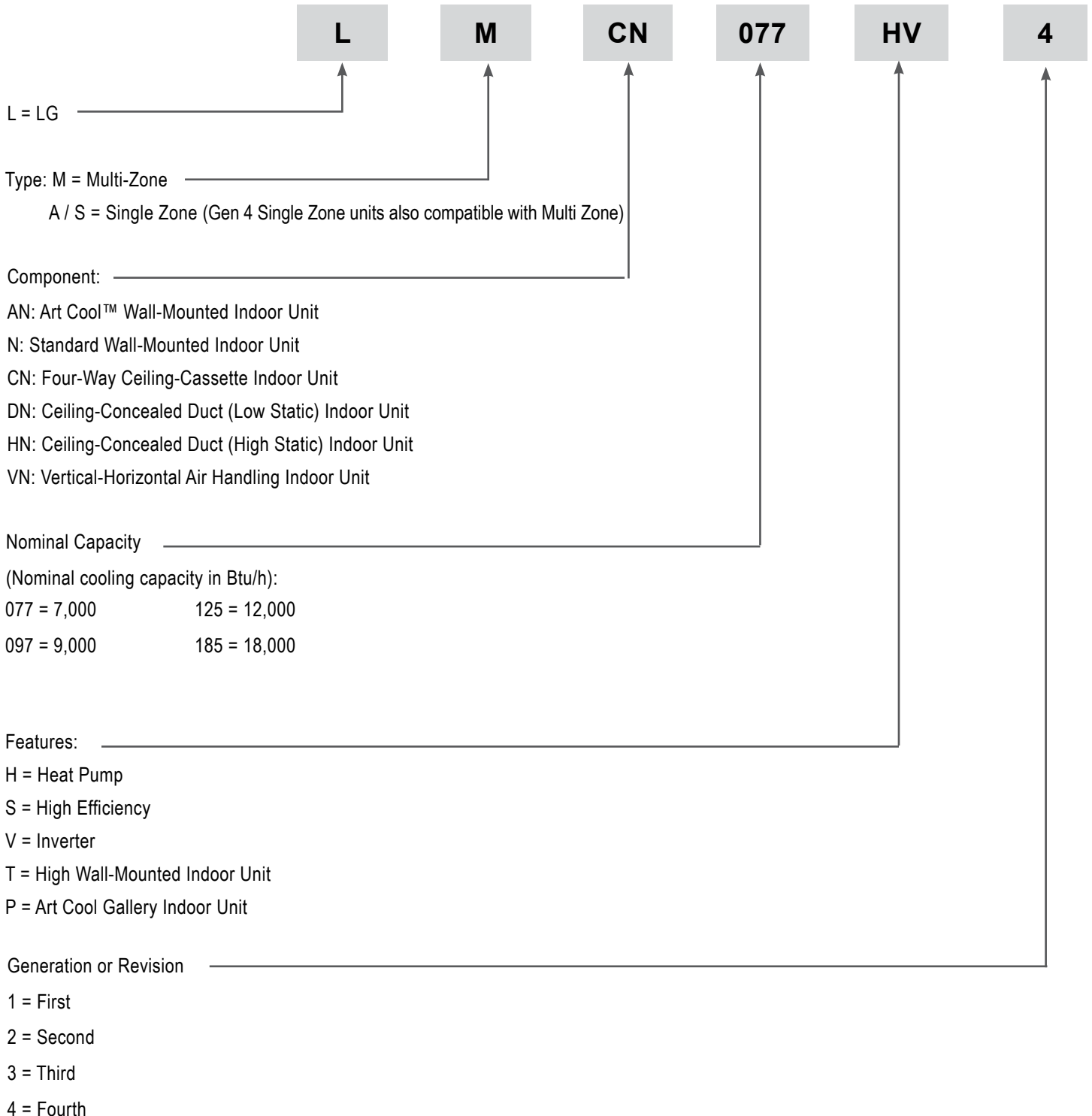

- Voltage for all equipment is 208-230V, 60 Hz, 1-phase.
- All indoor units are compatible with wired controllers



## R410A Refrigerant

R410A refrigerant has a higher operating pressure in comparison to R22 refrigerant and, therefore, all piping system materials installed must have a higher resisting pressure than the materials traditionally used in R22 systems.

R410A refrigerant is an azeotrope of R32 and R125, mixed at 50:50, so the ozone depletion potential (ODP) is 0.

### ⚠ WARNING

⊘ Do not place refrigerant cylinder in direct sunlight. Refrigerant cylinder may explode causing severe injury or death.

### Note

- Because R410A is a combination of R32 and R125, the required additional refrigerant must be charged in its liquid state. If the refrigerant is charged in its gaseous state, its composition changes and the system will not work properly.
- ⊘ Do not heat piping more than necessary during installation. Piping may become soft and fail when pressurized.
- ⊘ Do not use any piping that has not been approved for use in high-pressure refrigerant systems. Piping wall thickness must comply with the applicable local, state, and federal codes for the 551 psi design pressure of R410A. Inadequate piping may fail when pressurized.

## Allowable Indoor Unit to Outdoor Unit Connections

In Multi F / Multi F MAX multi-zone systems, the Ceiling Cassette IDUs can be connected to the Multi F outdoor units (ODUs) listed in the table below.

Table 4: Allowable Indoor Unit to Outdoor Unit Connections.

Indoor units		Outdoor units						
Model Number	Indoor Unit Nominal Capacity (Btu/h)	LMU18CHV	LMU24CHV	LMU30CHV	LMU36CHV	LMU480HV	LMU540HV	LMU600HV
		Maximum No. of Connectable Indoor Units						
		2	3	4	4	8	8	8
LMCN077HV	7,000	0	0	0	0	0	0	0
LCN097HV4	9,000	0	0	0	0	0	0	0
LCN127HV4	12,000	0	0	0	0	0	0	0
LMCN185HV	18,000	-	0	0	0	0	0	0

connection allowed: 0

connection not allowed: -

## Device Connection Limitations

- The minimum number of connected and operating indoor units to Multi F / Multi F MAX systems is two.
- The maximum number of indoor units for each Multi F / Multi F MAX heat pump system is:

LMU18CHV = 2    LMU24CHV = 3    LMU30CHV = 4    LMU36CHV = 4    LMU480HV = 8    LMU540HV = 8    LMU600HV = 8

- The maximum allowable total indoor unit capacity (Btu/h) for each Multi F / Multi F MAX heat pump system is:  
 LMU18CHV = 24,000    LMU30CHV = 40,000    LMU480HV = 65,000    LMU600HV = 81,000  
 LMU24CHV = 33,000    LMU36CHV = 48,000    LMU540HV = 73,000

- Refer to the Multi F Engineering Manual to properly determine total indoor unit connected capacity.

Table 5: Multi F Multi Zone Ceiling Cassette Indoor Unit Specifications.

Model Name	LMCN077HV	LCN097HV4	LCN127HV4	LMCN185HV
Grille (Sold Separately)	PT-QCHW0 / PT-UQC	PT-QCHW0 / PT-UQC	PT-QCHW0 / PT-UQC	PT-QCHW0 / PT-UQC
Nominal Cooling Capacity (Btu/h) <sup>1</sup>	7,000	9,000	12,000	18,000
Nominal Heating Capacity (Btu/h) <sup>1</sup>	8,100	10,400	13,800	20,800
<b>Operating Range</b>				
Cooling (°F WB)	57-77			
Heating (°F DB)	59-81			
<b>Fan</b>				
Type	Turbo			
Motor Output (W) x Qty.	43 x 1			
Motor/Drive	Brushless Digitally Controlled / Direct			
Airflow Rate CFM (H/M/L)	265 / 212 / 177	300 / 265 / 230	335 / 283 / 247	459 / 424 / 388
<b>Unit Data</b>				
Refrigerant Type <sup>2</sup>	R410A			
Refrigerant Control	EEV			
Power Supply V, Ø, Hz <sup>3</sup>	208-230, 1, 60			
Rated Amps (A)	0.25			
Sound Pressure Level ±3 dB(A) (H/M/L) <sup>4</sup>	31 / 27 / 24	36 / 33 / 30	38 / 35 / 32	38 / 37 / 34
Body Dimensions (W x H x D, in.)	22-7/16 x 8-7/16 x 22-7/16			22-7/16 x 10-3/32 x 22-7/16
Grille (PT-UQC, sold separately) Dimensions (WxHxD, in.)	27-9/16 x 7/8 x 27-9/16			
Body Net Weight (lbs.)	31			34
Grille (Sold separately) Net Weight (lbs.)	7			
Body Shipping Weight (lbs.)	34	37		42
Grille (Sold separately) Shipping Weight (lbs.)	11	9	9	11
Power Wiring / Communications Cable (No. x AWG) <sup>5</sup>	4 x 18			
Heat Exchanger (Row x Column x Fin / inch) x No.	(2 x 8 x 18) x 1			(2 x 10 x 18) x 1
<b>Pipe Size</b>				
Liquid (in.)	1/4			
Vapor (in.)	3/8			1/2
Drain O.D. / I.D. (in.)	1-1/4, 1			

<sup>1</sup>Nominal capacity is rated 0 ft. above sea level with corresponding refrigerant piping length in accordance with standard length of each outdoor unit and a 0 ft. level difference between outdoor and indoor units. All capacities are net with a combination ratio between 95 – 105%.

Nominal cooling capacity rating obtained with air entering the indoor unit at 80°F dry bulb (DB) and 67°F wet bulb (WB) and outdoor ambient conditions of 95°F dry bulb (DB) and 75°F wet bulb (WB).

Nominal heating capacity rating obtained with air entering the indoor unit at 70°F dry bulb (DB) and 60°F wet bulb (WB) and outdoor ambient conditions of 47°F dry bulb (DB) and 43°F wet bulb (WB).

<sup>2</sup>This unit comes with a dry helium charge.

<sup>3</sup>Acceptable operating voltage: 187V-253V.

<sup>4</sup>Sound pressure levels are tested in an anechoic chamber under ISO Standard 3745 and are the same in both cooling and heating mode. These values can increase due to ambient conditions during operation.

<sup>5</sup>All power wiring / communications cable to the IDUs be minimum 18 AWG, 4-conductor, stranded, shielded or unshielded (if shielded, must be grounded to chassis at ODU only) and must comply with applicable local and national codes.

Figure 2: Multi F Four-Way Ceiling-Cassette Indoor Unit Refrigerant Flow Diagram.

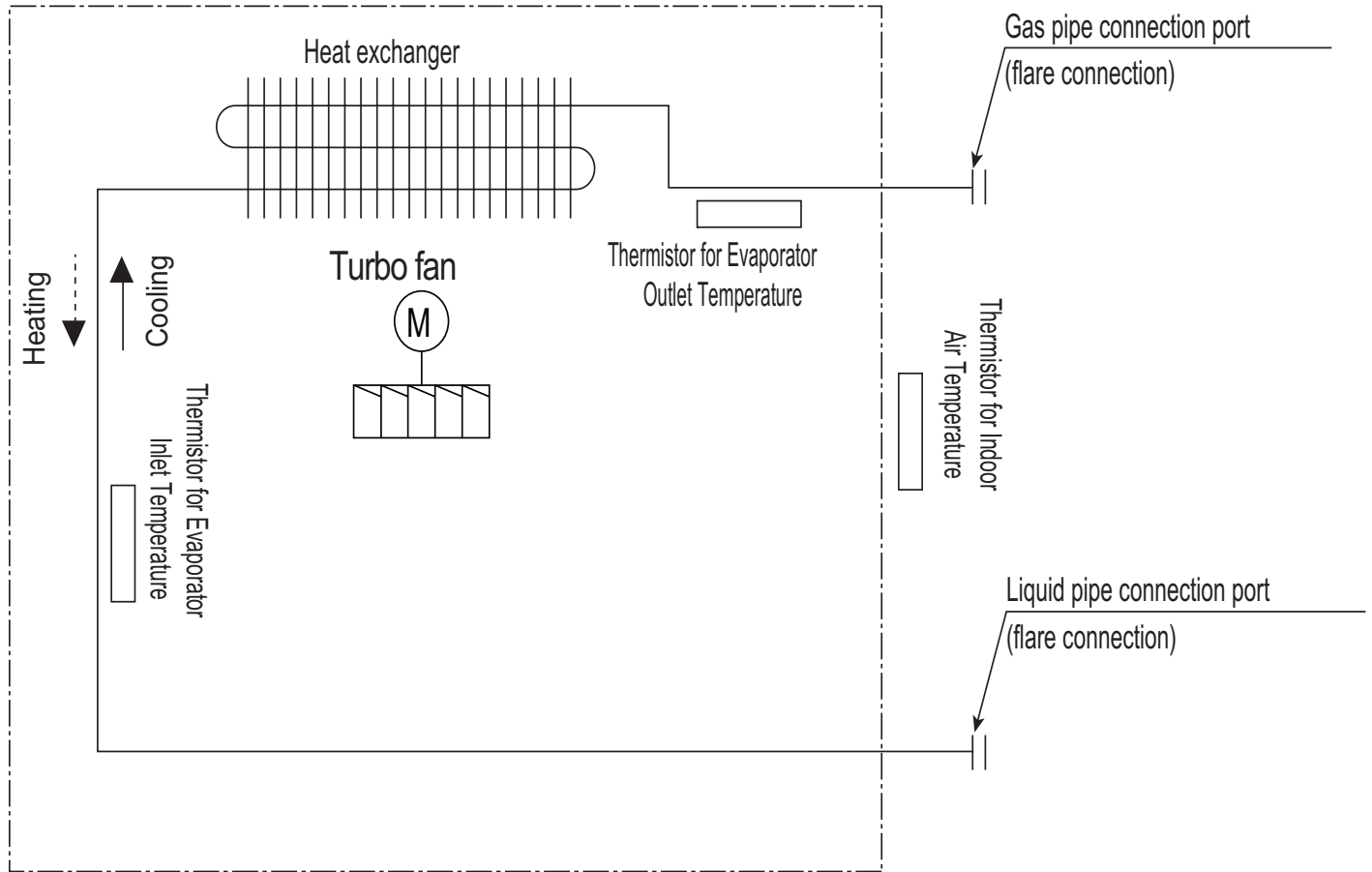

Table 6: Multi F Multi Zone Art Cool Mirror Wall-Mounted Indoor Unit Refrigerant Pipe Connection Port Diameters.

Model No.	Vapor (inch)	Liquid (inch)
LMCN077HV	Ø3/8	Ø1/4
LCN097HV4		
LCN127HV4		
LMCN185HV	Ø1/2	

### Major System Components

A typical Multi F system consists of an outdoor unit (ODU), refrigerant piping, and two (2) to four (4) indoor units (IDUs). The ceiling cassette units described in this manual are one of the types of IDUs that can be connected to a Multi F system.

A typical Multi F Max system consists of an ODU, refrigerant piping, one or two branch distribution units (BDU), and two (2) to eight (8) IDUs. The ceiling cassette units described in this manual are one of the types of IDUs that can be connected to a Multi F Max system.

### Typical Multi F System

Example: LMU36CHV outdoor unit with four (4) indoor units connected.

ODU: Outdoor Unit.

IDU: Indoor Unit.

A, B, C, D: Piping from Outdoor Unit to Indoor Unit.

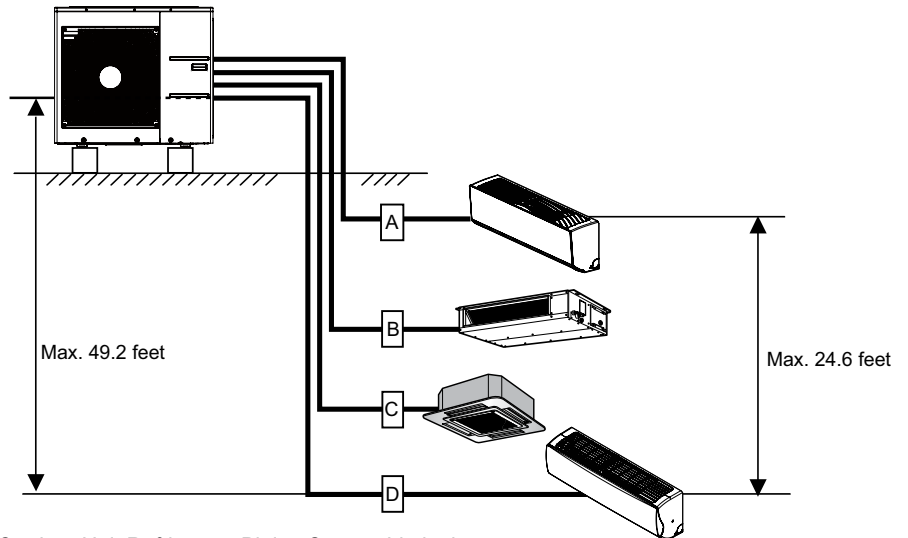

Table 7: Multi F Outdoor Unit Refrigerant Piping System Limitations.

Outdoor Unit	Minimum Length for Each Pipe Segment (ft.)	Maximum Equivalent Pipe Length to Each Indoor Unit (ft.)				Maximum Equivalent Pipe Length for Each System (ft.)
		A	B	C	D	
LMU18CHV	9.8	82	82	-	-	164
LMU24CHV	9.8	82	82	82	-	246.1
LMU30CHV	9.8	82	82	82	82	246.1
LMU36CHV	9.8	82	82	82	82	246.1

### Typical Multi F MAX System with One Branch Distribution Unit

Example: LMU540HV outdoor unit with four (4) indoor units, and one (1) branch distribution unit connected.

ODU: Outdoor Unit.

IDU: Indoor Unit.

BDU: Branch Distribution Unit.

A: Main Piping.

B: Branch Piping (Branch Distribution Unit to Indoor Unit[s]).

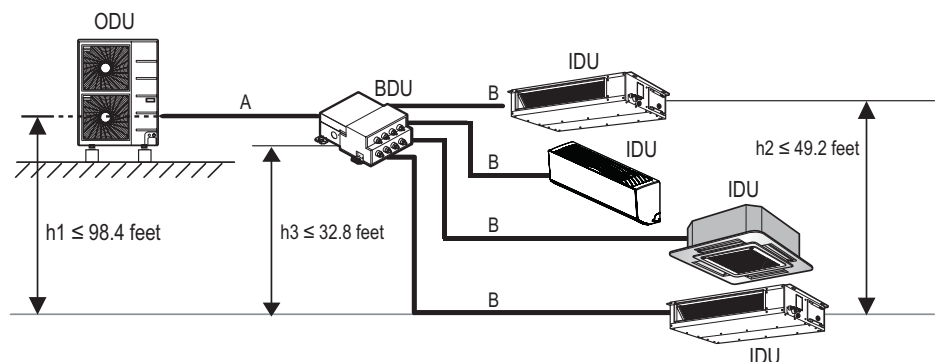

# GENERAL DATA

Typical Multi F/Multi F Max Systems

**MULTI F**  
**MULTI F MAX**

## Typical Multi F MAX System with Two Branch Distribution Units

Example: LMU540HV outdoor unit with seven (7) indoor units, and two (2) branch distribution units connected.

ODU: Outdoor Unit.

IDU: Indoor Unit.

BD: Branch Distribution Unit(s).

$\Sigma A$ : Main Piping.

$\Sigma B$ : Branch Piping (Branch Distribution Unit[s] to Indoor Unit[s]).

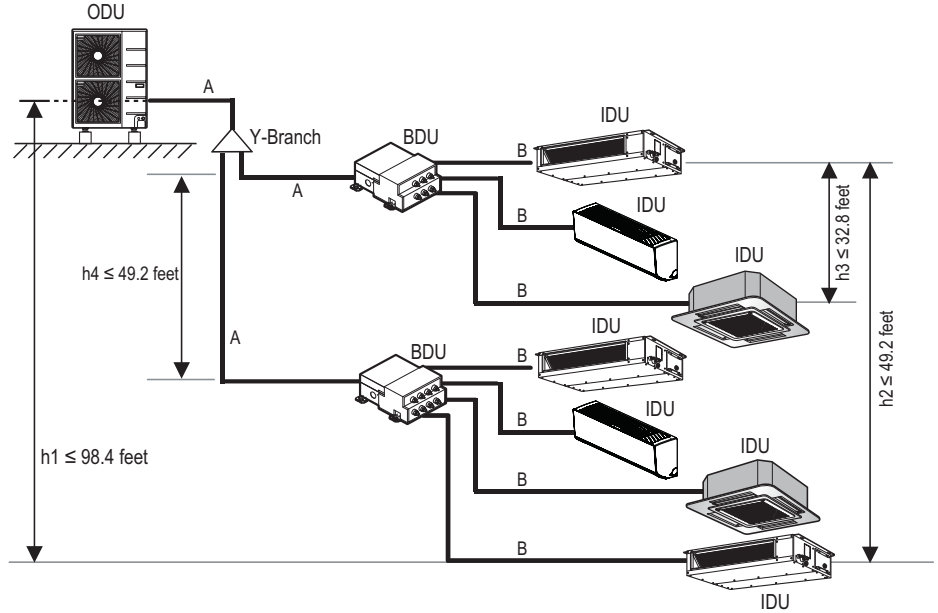

Table 8: Multi F MAX LMU480HV, LMU540HV, and LMU600HV Outdoor Unit Refrigerant Piping System Limitations.

Pipe Length (ELF = Equivalent Length of pipe in Feet)	Total piping length ( $\Sigma A + \Sigma B$ )		≤475.7 feet
	Main pipe (Outdoor Unit to Branch Distribution Units: $\Sigma A$ )	Minimum	9.8 feet
		Maximum	≤180.4 feet
	Total branch piping length ( $\Sigma B$ )		≤295.3 feet
	Branch pipe (Branch Distribution Units to Indoor Units: B)	Minimum	9.8 feet
Maximum		≤49.2 feet	

Elevation Differential (All Elevation Limitations are Measured in Actual Feet)	If outdoor unit is above or below indoor unit (h1)		≤98.4 feet
	Between the farthest two indoor units (h2)		≤42.9 feet
	Between branch distribution unit and farthest connected indoor unit(s) (h3)		≤32.8 feet
	Between branch distribution units (h4)		≤42.9 feet

Table 9: Multi F MAX Piping Sizes.

Piping	Main Pipe A (inch)	Branch Pipe B
Liquid	Ø3/8	Depends on the size of the indoor unit piping
Gas	Ø3/4	

Multi F Ceiling Cassette Indoor Unit

### Field Supplied Refrigerant Piping

Type ACR copper is the only approved refrigerant pipe material for use with LG Multi F air conditioning products. ACR rated tubing is the only type that ships with yellow caps. Approved tubing for use with Multi F products will be marked "R410 RATED" along the length of the tube. Tube wall thickness should meet local code requirements and be approved for a maximum operating pressure of 551 psi.

Refer to the refrigerant piping section (starting on page 23) of the General Installation Guidelines for more information on piping.

### Using Refrigerant Components

Field-supplied elbows are allowed if they are long radius and designed for use with R410A refrigerant. Be sure to account for the additional pressure losses in equivalent pipe length calculations for each elbow, Y-branch, and branch distribution unit. The equivalent pipe length of each elbow, Y-branch, and/or branch distribution unit must be added to each pipe segment to ensure maximum lengths are not exceeded.

Table 10: Equivalent Piping Length for Elbows, Y-branches, and Branch Distribution Units.

Component	Size (Inches)				
	1/4	3/8	1/2	5/8	3/4
Elbow (ft.)	0.5	0.6	0.7	0.8	1.2
Y-Branch Kit (ft.) (Multi F MAX systems only) <sup>1</sup>	1.6				
Branch Distribution Unit (ft.) (Multi F MAX systems only)	8.2				

<sup>1</sup>Kit contains two Y-branches: one for liquid and one for vapor.

## Location Selection

### **⚠ DANGER**

⊘ To avoid the possibility of fire, do not install the unit in an area where combustible gas may generate, flow, stagnate, or leak. Installing the unit in an area containing combustible gas will cause serious bodily injury or death.

#### **Note:**

Before beginning installation, read the safety summary at the beginning of this manual.

Select a location for installing the ceiling cassette indoor unit (IDU) that meets the following conditions:

- Place the unit where air circulation will not be blocked.
- Place the unit where drainage can be obtained easily.
- Place the unit where noise prevention is taken into consideration.
- Ensure there is sufficient strength to bear the load of the indoor unit.
- Ensure there is sufficient maintenance space.
- Locate the indoor unit in a location that is level, and where it can be easily connected to the outdoor unit / branch distribution unit.

### **⚠ WARNING**

The unit may be damaged, may malfunction, and / or will not operate as designed if installed in any of the conditions listed.

- ⊘ The unit should not be installed near a heat or steam source, or where considerable amounts of oil, iron powder, or flour are used.
- ⊘ Do not install the unit in an area where combustible gas may generate, flow, vent into, stagnate, leak, or be stored.
- ⊘ Do not install the unit in a location where acidic solution and spray (sulfur) are often used.
- ⊘ Do not use the unit in environments where oil, steam, or sulfuric gas are present.
- ⊘ Avoid installing the unit near high-frequency generators or near any equipment that generates an electromagnetic field (minimum 3-1/3 feet away)
- ⊘ Do not install the unit near a doorway.

#### **Note:**

If the unit is installed near a body of water, certain components are at risk of being corroded. Appropriate anti-corrosion methods should be taken for the unit and all components.

#### **Installing in a High or Dropped Ceiling**

High or dropped ceilings, often found in commercial buildings and offices, may cause a wide temperature differentiation. To countermeasure:

- Change the indoor unit mode selection to allow for higher ceilings (see table).
- Install an air circulator.
- Set the air discharge outlet so that heated air flows in a downward direction.
- Use a dual door system to protect the building gate or exit.

Table 11: Ceiling Cassette Indoor Unit High Ceiling Mode Selection Options.

Ceiling Height	Mode Selection
≤7-1/2 feet	Low Ceiling
7-1/2 feet to 8-7/8 feet	Standard
8-7/8 feet to 10-3/16 feet	High Ceiling
10-3/16 feet to 11-13/16 feet	Very High Ceiling

#### **Installing in an Area Exposed to Unconditioned Air**

In some installation applications, areas (floors, walls) in some rooms may be exposed to unconditioned air (room may be above or next to an unheated garage or storeroom). To countermeasure:

- Verify that carpet is or will be installed (carpet may increase the temperature by three (3) degrees).
- Add insulation between the floor joists.
- Install radiant heat or another type of heating system to the floor.

Multi F Ceiling Cassette Indoor Unit

**Installing in an Area with High Humidity Levels**

If the environment is prone to humidity levels of 80% or more (near the ocean, lakes, etc.) or where steam could collect in the plenum:

- Install additional insulation to the indoor unit (glass wool insulation >13/32 inches thick).
- Install additional insulation to the refrigerant piping (insulation >13/16 inches thick).
- Seal all gaps between the indoor unit and the ceiling tiles (make the area air tight) so that humidity does not transfer from the plenum to the conditioned space. Also, add a ceiling grille for ventilation.

Figure 3: Installing in a Highly Humid Location.

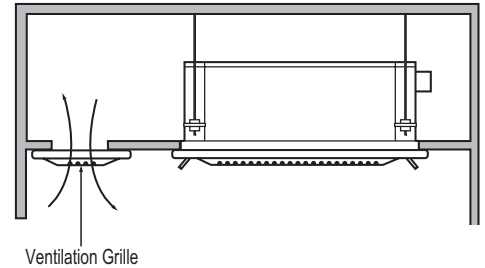

**Installing Multiple Indoor Units in One Area**

Ensure there is enough space between indoor units, lighting fixtures, and ventilation fans / systems.

Figure 4: Installing Multiple Indoor Units.

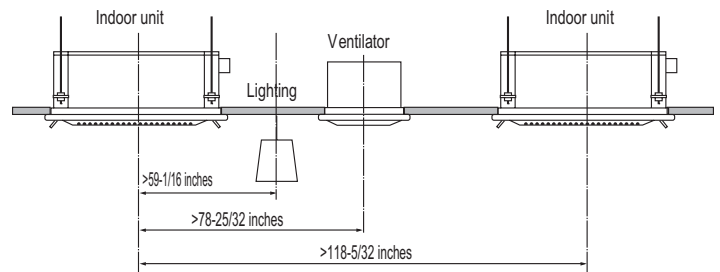

**Required Clearances**

Figure 5 shows required clearance distances around a typical installed unit.

Figure 5: Required Clearances Around Typical Installed Unit.

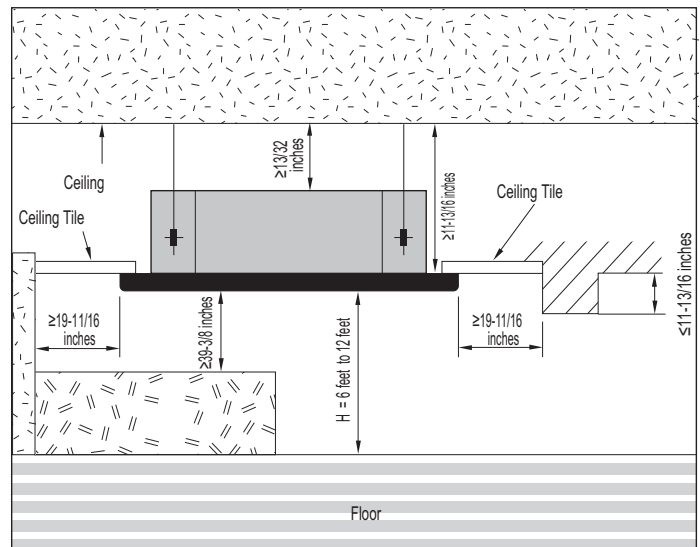

**Unpack and Inspect for Freight Damage**

**CAUTION**

Shipping and net weights of the ceiling cassette units are listed in Table 5. To help avoid injury to personnel, use two people when carrying a unit by hand.

**Note:**

- Do not unpack the unit and remove the protective materials until ready to install. Before unpacking, carefully move the packaged unit to a work area near the installation location.
- To help avoid damage to the unit, use two people when carrying a unit by hand.

After opening, if the unit is damaged, repack the unit as it was shipped. **RETAIN ALL PACKING MATERIALS.** In general, freight damage claims will be denied if the original packing materials are not retained for the claims adjustor to inspect. Contact a supervisor on how to proceed with filing a freight claim and to order a replacement unit.

**Note:**

Before opening the shipping container, check the container labeling to verify the unit received is the correct unit. Verify the unit capacity, type, and voltage.

### Unpack and Inspect for Freight Damage, continued.

1. Before opening the shipping container, verify the correct unit is included as described in the note on the previous page.
2. Place the box on a solid surface right side up.
3. Cut the white reinforced nylon straps.
4. Open the box.
5. Remove any protective cardboard / Styrofoam® top sheets and place to the side.
6. The walls and top panels are not attached to the bottom of the box. Lift the cardboard carton by the flaps and remove the box walls and top and place it to the side.
7. Remove the moisture barrier plastic bonnet.
8. Check the unit nameplate data and model number. Verify the unit voltage, and capacities are correct before proceeding.
9. Locate and retain all included accessories.
10. Using two people, carefully lift the unit and inspect for freight damage. ⚠ DO NOT lift by the refrigerant piping or drain pipe stub. Lift by the frame only. If damage is found, repack the unit as it was received in the original container.
11. If the unit is undamaged, remove and retain the installation manual.

## Preparing the Installation Area and Hanging the Indoor Unit Frame

### Preparing the Installation Area

1. Installation guide (template) depicts the exact dimensions necessary for the ceiling opening.
2. Choose the location for the indoor unit, and then mark where the suspension bolts, refrigerant piping, and drain hose should be. Suspension bolt angle should account for drain direction.
3. Drill holes for the bolts. Use either a W 3/8 inch or a M10 size bolt.

### Note:

For easier installation, attach the accessories (except for the decoration panel) before hanging the indoor unit.

Figure 6: Using the Level.

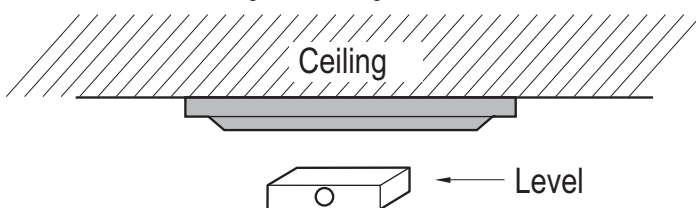

Figure 7: Drilling Holes Using Template.

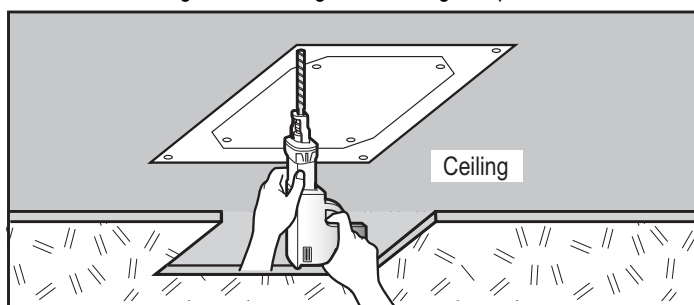

Figure 8: Ceiling Opening Dimensions and Bolt Locations.

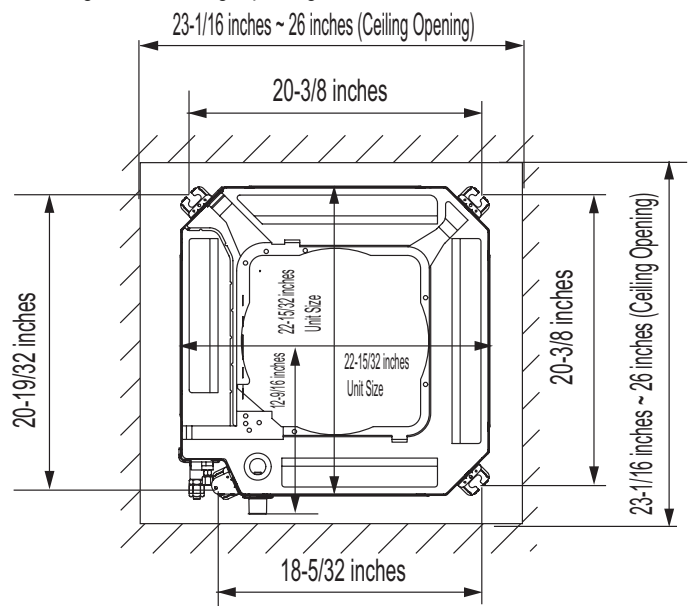

Figure 9: Installing the Hanging Bolt in the Ceiling.

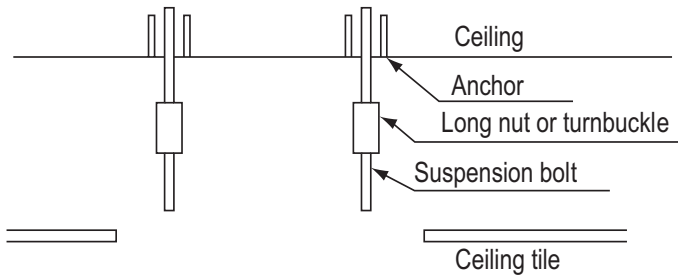
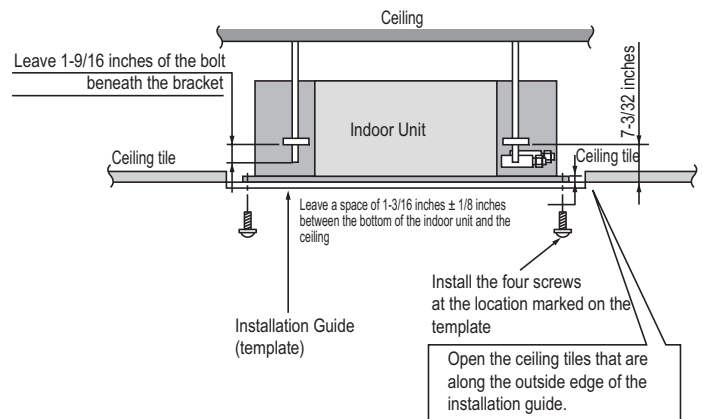

Figure 10: Installation Diagram.



**For New Ceilings**

1. Use a sunken insert, a sunken anchor, or any other field-supplied part to reinforce the ceiling so that it can bear the weight of the indoor unit. Use a temporary washer plate to more easily set up the unit suspension location.
2. Ceiling height is shown on the side of the installation guide (template). Adjust the height of the unit accordingly. Adjust the clearance before hanging the indoor unit.
3. Refer to the installation guide (template) for the dimensions to the ceiling opening. Match the center of the indoor unit (labeled) to the center indicated on the installation guide.
4. Align the installation guide (template) with the label attached to the unit (affixing the template to the unit if desired) to properly place the unit.
5. Remove the temporary washer plate and position the indoor unit hanger brackets on the bolts. Secure with nuts and washers on the top and bottom of the hanger brackets.
6. Ceiling-cassette indoor units are equipped with a built-in drain pump and float switch, therefore, the unit must be installed horizontally or condensate will drip out and cause product malfunction. Measure the unit at each corner to verify that it is level.
7. Remove the installation guide (template).

Figure 11: Hanging the Indoor Unit.

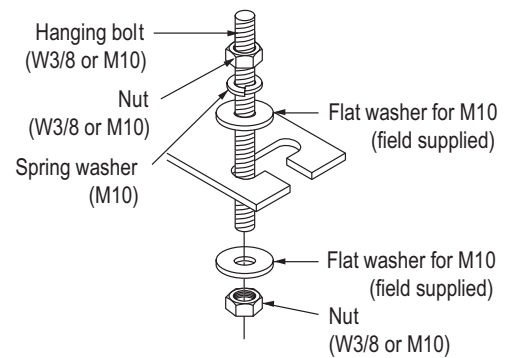

**For Existing Ceilings**

1. Use anchors when installing the indoor unit in an existing ceiling.
2. Ceiling height is shown on the side of the installation guide (template). Adjust the height of the unit accordingly. Adjust the clearance before hanging the indoor unit.
3. Remove the temporary washer plate and position the indoor unit hanger brackets on the bolts. Secure with nuts and washers on the top and bottom of the hanger brackets.
4. Ceiling-cassette indoor units are equipped with a built-in drain pump and float switch, therefore, the unit must be installed horizontally or condensate will drip out and cause product malfunction. Measure the unit at each corner to verify that it is level.
5. Remove the installation guide (template).

### Installing the Drain System

- The unit uses a drain pump with a height of up to 27-9/16 inches to remove condensate from the indoor unit to the drainage system. To ensure proper drainage, the flexible drain piping and any field-supplied drain piping should be installed below the maximum height.
- Field-supplied drain piping must have downward gradient of at least 1/50 to 1/100; to prevent reverse flow, slope should not be straight up and down.
- ⚠ Do not damage the drain port on the indoor unit when connecting the flexible drain hose or field-supplied drain piping.
- Drain piping specifications:
  - Indoor Unit Drain Connection (Flexible Drain Hose): 1-1/4 inch outside diameter.

**Note:**

The supplied flexible drain hose should not be installed with a sharp curve or twist. A curved or twisted hose may become damaged due to vibration and / or leak.

- Field-Supplied Drain Piping: Polyvinyl chloride piping with 1-inch inside diameter and pipe fittings.

**Note:**

Condensate can be drained either directly outside or to a common drain system. For more information regarding the common drain system, see the Multi F / Multi F MAX Outdoor Unit Engineering Manual

If the field drain piping and / or the common drain system is long, it is recommended that clamp hangers be installed for support.

Table 12: Recommended Drain Piping Support Intervals.

Piping Dia. (Inch)	Ø3/4" ~ 1-1/2"	Ø1-1/2" ~ 2"	Ø2-1/2" ~ 5"
Maximum Interval (feet)	<3.3	<3.9	<4.9

### Checking the Drain Pump

The drain pump must be tested before the system operates.

- Connect flexible drain hose to the field-supplied drain piping; leave it as is until the test is complete.
- Pour water into the flexible drain hose and check for leaks.
- After power wiring installation is complete, operate the drain pump to see if it sounds and functions properly.
- After the test is complete, connect the flexible drain hose to the indoor unit drain port.

Figure 12: Ceiling Cassette Indoor Unit Drain System.

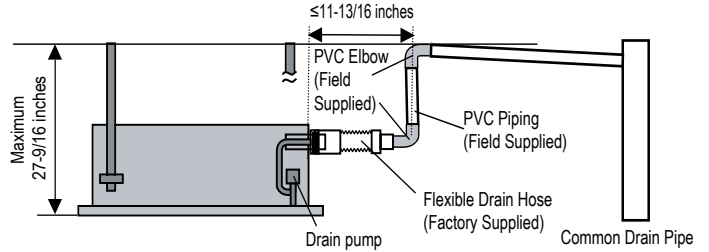

Figure 13: Drain Slope.

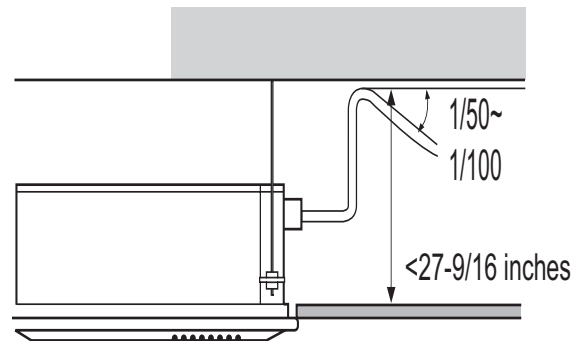

Figure 14: Correct (Another View) and Incorrect Drain Slopes.

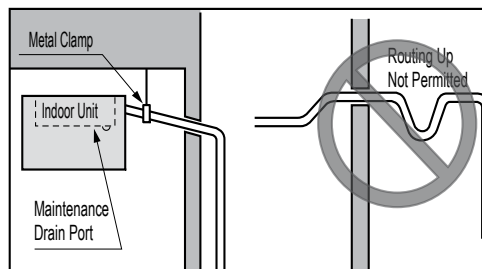
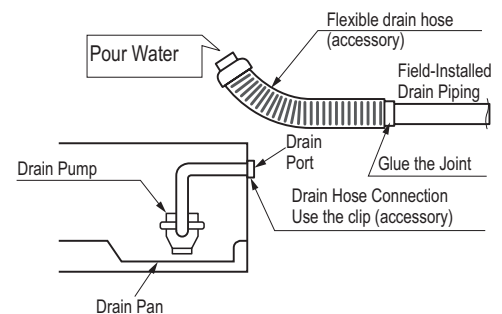

Figure 15: Flexible Drain Hose Connection.



Clamp the Flexible Drain Hose Connection

Figure 16: Checking the Drain Pump.



## Insulating the Drain Piping

- Drain piping insulation should be made of polyethylene foam with a minimum thickness of 7/16 inches.
- Secure drain hose insulation at the drain port connection on the indoor unit so that no gaps exist.

### Note:

LG Electronics U.S.A., Inc., is not responsible for any piping calculations, refrigerant leaks, degradation of performance, or any other potential problems or damages as a result of interconnecting piping, their joint connections, isolation valves, introduced debris inside the piping system, or other problems caused by the interconnecting piping system.

## No Pipe Size Substitutions

Use only the pipe size selected by the LATS Multi F pipe system design software or as conveyed in the product installation instructions. Using a different size is prohibited and may result in a system malfunction or failure to work at all.

## Pipe Slope

The horizontal pipe slope cannot exceed 10° up or down. Y-branches have additional restrictions described on the next page.

## In-line Refrigeration Components

Components such as oil traps, solenoid valves, filter-dryers, sight glasses, tee fittings, and other after-market accessories are not permitted on the refrigerant piping system between the outdoor units and the indoor / branch distribution units.

Multi F / Multi F Max systems have redundant systems that ensure oil is properly returned to the compressor. Sight-glasses and solenoid valves may cause vapor to form in the liquid stream.

### Note:

Over time, dryers may deteriorate and introduce debris into the system. The designer and installer should verify the refrigerant piping system is free of traps, sagging pipes, sight glasses, filter dryers, etc.

## Field-Provided Isolation Ball Valves

LG maintains a neutral position on using isolation valves in VRF refrigerant piping systems. LG does not endorse any manufacturer of isolation valves. It is recognized that installing isolation valves may simplify future maintenance requirements, and, if used, considerations should be taken including, but not limited to, the following:

- Pressure drops for any component used, including isolation valves, must be known in equivalent pipe length and calculated into the total and segment equivalent piping lengths and compared to product design limitations.
- In all cases, materials must be suitable for the application and any applicable codes, including, but not limited to, diameter and wall thickness continuity per ACR standards.

Failure to do so may cause significant performance degradation. Proper leak checks must be performed. Using isolation valves does not automatically void any LG product warranty; however, a limited warranty may be voided in whole or part should any field supplied accessory fail in any way that causes product failure.

## Obstacles

When an obstacle, such as an I-beam or concrete T, is in the path of the planned refrigerant pipe run, it is best practice to route the pipe over the obstacle. If adequate space is not available to route the insulated pipe over the obstacle, then route the pipe under the obstacle. In either case, it is imperative the horizontal section of pipe above or below the obstacle be a minimum of three (3) times greater than the longest vertical rise (or fall) distance.

Figure 17: Insulating the Drain Piping.

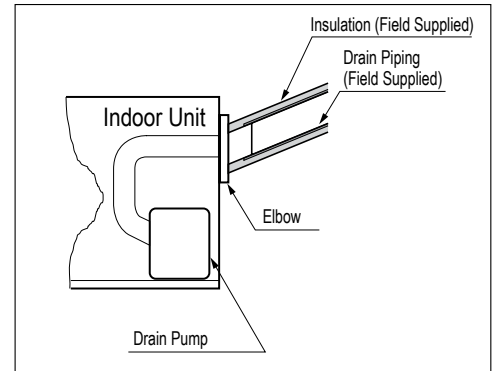
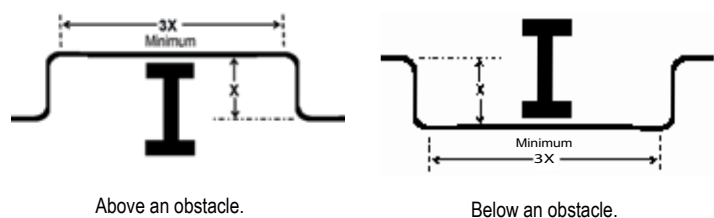

Figure 18: Installing Piping Above and Below an Obstacle.



### Multi F MAX Y-Branch Kit PMBL5620

The LG supplied Y-Branch Kit PMBL5620 MUST be used when two branch distribution units are connected to one Multi F MAX system. Field-supplied fittings are not permitted. Each Y-branch kit comes with two (2) Y-branches (one for the liquid line and one for the vapor line) and insulation covers.

Y-branches may be installed in horizontal or vertical configurations. When installed vertically, position the Y-branch so the straight-through leg is  $\pm 3^\circ$  of plumb. When installed horizontally, position the Y-branch so the take-off leg is level and shares the same horizontal plane as the straight-through leg  $\pm 5^\circ$  rotation.

Y-branches should always be installed with the single port facing the outdoor unit and the two-port end facing the branch distribution units. Do not install Y-branches backwards as refrigerant flow cannot make U-turns. The Y-branch kit must be located at least three (3) feet from the outdoor unit. Provide a minimum of 20 inches between a Y-branch and the branch distribution unit.

Figure 19: Y-Branch Port Identification and Dimensions.

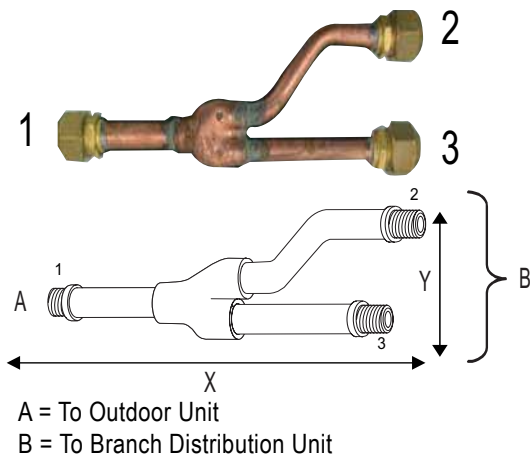

Table 13: Multi F MAX Y-Branch Connection Diameters.

Model	Y-Branch Type	Port Identifier (inch)		
		1	2	3
PMBL5620	Liquid	Ø3/8	Ø3/8	Ø3/8
	Vapor	Ø3/4	Ø3/4	Ø3/4
	Y-Branch Type	Dimensions (inch)		
		X	Y	
	Liquid	13.80	3.24	
	Vapor	12.48	3.02	

Figure 21: Y-branch Vertical Installation Alignment.

Vertical Up Configuration      Vertical Down Configuration

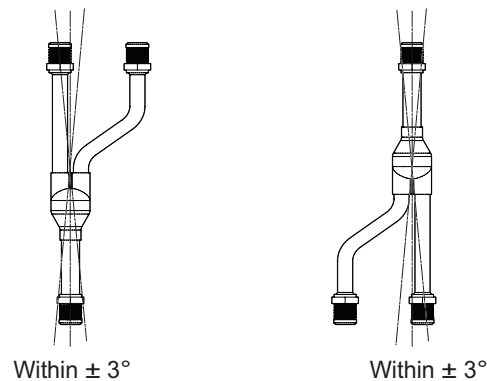
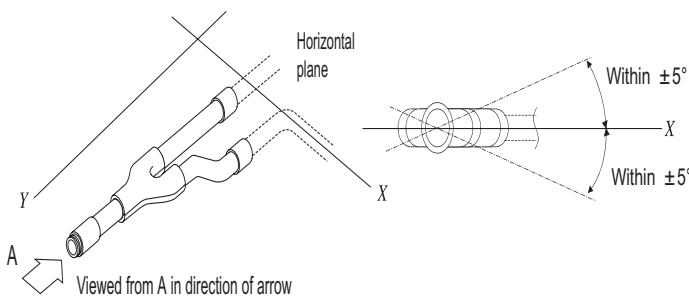

Figure 20: Y-branch Horizontal Installation Alignment.



### Y-Branch Kit Insulation

Each Y-branch kit comes with clam-shell type peel-and-stick insulation jackets molded to fit the Y-branch fittings—one for the liquid line, one for the vapor line.

Table 14: Insulation Jacket Properties.

<b>Material</b>	Polyolefin Foam
<b>UL94 Flame Classification</b>	HF-1
<b>Density</b>	1.84 lbs./ft. <sup>3</sup>
<b>Thermal Conductivity</b>	.0208 Btu/h/ft. °R
<b>Thickness</b>	1/2 inch

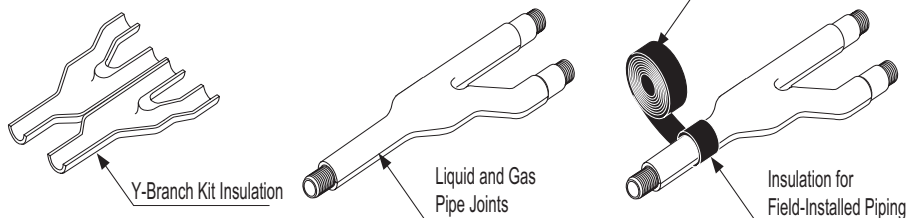

Figure 22: Y-Branch Insulation Jacket Diagram.

## Selecting Field-Supplied Copper Tubing

Copper is the only approved refrigerant pipe material for use with Multi F products, and LG recommends seamless phosphorous deoxidized ACR type copper pipe, hard-drawn rigid type “K” or “L”, or annealed-tempered, copper pipe.

- Drawn temper (rigid) ACR copper tubing is available in sizes 3/8 through 2-1/8 inches (ASTM B 280, clean, dry, and capped).
- Annealed temper (soft) ACR copper tubing is available in sizes 1/4 through 2-1/8 inches (ASTM B 280, clean, dry, and capped).

**Note:**

Tube wall thickness should meet local code requirements and be approved for an operating pressure of 551 psi. If local code does not specify wall thickness, LG suggests using tube thickness per table below. When bending tubing, try to keep the number of bends to a minimum, and use the largest radii possible to reduce the equivalent length of installed pipe; also, bending radii greater than ten (10) pipe diameters can minimize pressure drop. Be sure no traps or sags are present when rolling out soft copper tubing coils.

Table 15: ACR Copper Tubing Material.

Type	Seamless Phosphorous Deoxidized
Class	UNS C12200 DHP
Straight Lengths	H58 Temper
Coils	O60 Temper

Table 16: Piping Tube Thicknesses.

OD (in)	1/4	3/8	1/2	5/8	3/4	7/8	1-1/8	1-3/8	1-5/8
Material	Rigid Type “K” or “L” and Soft ACR Acceptable			Rigid Type “K” or “L” Only					
Min. Bend Radius (in)	.563	.9375	1.5	2.25	3.0	3.0	3.5	4.0	4.5
Min. Wall Thickness (in)	.03	.03	.035	.040	.042	.045	.050	.050	.050

Table 17: ACR Copper Tubing Dimensions and Physical Characteristics.<sup>1-4</sup>

Nominal Pipe Outside Diameter (in)	Actual Outside Diameter (in)	Drawn Temper			Annealed Temper		
		Nominal Wall Thickness (in)	Weight (lb/ft)	Cubic ft per Linear ft	Nominal Wall Thickness (in)	Weight (lb/ft)	Cubic ft per Linear ft
1/4	0.250	--	--	--	0.030	0.081	.00020
3/8	0.375	0.030	0.126	.00054	0.032	0.134	.00053
1/2	0.500	0.035	0.198	.00101	0.032	0.182	.00103
5/8	0.625	0.040	0.285	.00162	0.035	0.251	.00168
3/4	0.750	0.042	0.362	.00242	0.042	0.362	.00242
7/8	0.875	0.045	0.455	.00336	0.045	0.455	.00336
1-1/8	1.125	0.050	0.655	.00573	0.050	0.655	.00573

<sup>1</sup>All dimensions provided are in accordance with ASTM B280 – Standard.

<sup>2</sup>Design pressure = 551 psig.

<sup>3</sup>ACR Tubing is available as hard drawn or annealed (soft) and are suitable for use with R410A refrigerant.

<sup>4</sup>The Copper Tube Handbook, 2010, Copper Development Association Inc., 260 Madison Avenue, New York, NY 10016.

**Note:**

- Commercially available piping often contains dust and other materials. Always blow it clean with a dry, inert gas.
- Prevent dust, water or other contaminants from entering the piping during installation. Contaminants can cause mechanical failure.

### No Pipe Size Substitutions

**Note:**

Use only the pipe size recommended by this installation manual. Using a different size is prohibited and may result in system malfunction or failure.

### Copper Expansion and Contraction

Under normal operating conditions, the vapor pipe temperature of a Duct Free System can vary as much as 280°F. With this large variance in pipe temperature, the designer must consider pipe expansion and contraction to avoid pipe and fitting fatigue failures.

Refrigerant pipe along with the insulation jacket form a cohesive unit that expands and contracts together. During system operation, thermal heat transfer occurs between the pipe and the surrounding insulation.

If the pipe is mounted in free air space, no natural restriction to movement is present if mounting clamps are properly spaced and installed. When the refrigerant pipe is mounted underground in a utility duct stacked among other pipes, natural restriction to linear movement is present. In extreme cases, the restrictive force of surface friction between insulating jackets could become so great that natural expansion ceases and the pipe is “fixed” in place. In this situation, opposing force caused by change in refrigerant fluid/vapor temperature can lead to pipe/fitting stress failure.

The refrigerant pipe support system must be engineered to allow free expansion to occur. When a segment of pipe is mounted between two fixed points, provisions must be provided to allow pipe expansion to naturally occur. The most common method is the inclusion of expansion Loop or U-bends. Each segment of pipe has a natural fixed point where no movement occurs. This fixed point is located at the center point of the segment assuming the entire pipe is insulated in a similar fashion. The natural fixed point of the pipe segment is typically where the expansion Loop or U-bend should be.

Linear pipe expansion can be calculated using the following formula:

$$LE = C \times L \times (T_r - T_a) \times 12$$

- LE = Anticipated linear tubing expansion (in.)
- C = Constant (For copper =  $9.2 \times 10^{-6}$  in./in.°F)
- L = Length of pipe (ft.)
- T<sub>R</sub> = Refrigerant pipe temperature (°F)
- T<sub>a</sub> = Ambient air temperature (°F)
- 12 = Inches to feet conversion (12 in./ft.)

1. In Table 18 find the row corresponding with the actual length of the straight pipe segment.
2. Estimate the minimum and maximum temperature of the pipe. In the column showing the minimum pipe temperature, look up the anticipated expansion distance. Do the same for the maximum pipe temperature.
3. Calculate the difference in the two expansion distance values. The result will be the anticipated change in pipe length.

**Example:**

A system is installed and the design shows that there is a 100 foot straight segment of tubing between an indoor unit and the outdoor unit. In heating, this pipe transports hot gas vapor to the indoor units at 120°F. In cooling, the same tube is a suction line returning refrigerant vapor to the outdoor unit at 40°F. Look up the copper tubing expansion at each temperature and calculate the difference.

**Vapor Line**

Transporting Hot Vapor: 100 ft. pipe at 120 °F = 1.40 in.

Transporting Suction Vapor: 100 ft. pipe at 40 °F = 0.40 in.

Anticipated Change in Length: 1.40 in. – 0.40 in. = 1.00 in.

**Liquid Line**

The liquid temperature remains relatively the same temperature; only the direction of flow will reverse. No significant change in length of the liquid line, therefore, is anticipated.

When creating an expansion joint, the joint height should be a minimum of two times the joint width. Although different types of expansion arrangements are available, the data for correctly sizing an Expansion Loop is provided in Table 19. Use soft copper with long radius bends on longer runs or long radius elbows for shorter pipe segments. Using the anticipated linear expansion (LE) distance calculated, look up the Expansion Loop or U-bend minimum design dimensions. If other types of expansion joints are chosen, design per ASTM B-88 Standards.

See table below for precalculated anticipated expansion for various pipe sizes and lengths of refrigerant tubing.

**To find the anticipated expansion value:**

1. From the table below, find the row corresponding with the actual feet of the straight pipe segment.
2. Estimate the minimum and maximum temperature of the pipe.
3. In the column showing the minimum pipe temperature, look up the anticipated expansion distance corresponding to the segment length. Do the same for the maximum pipe temperature.
4. Calculate the difference in the two expansion distance values. The result will be the change in pipe length.

Table 18: Linear Thermal Expansion of Copper Tubing in Inches.

Pipe Length <sup>1</sup>	Fluid Temperature °F																			
	35°	40°	45°	50°	55°	60°	65°	70°	75°	80°	85°	90°	95°	100°	105°	110°	115°	120°	125°	130°
10	0.04	0.04	0.05	0.06	0.06	0.07	0.08	0.08	0.09	0.09	0.10	0.10	0.11	0.11	0.11	0.12	0.13	0.14	0.15	0.15
20	0.08	0.08	0.10	0.12	0.13	0.14	0.15	0.16	0.17	0.18	0.19	0.20	0.21	0.22	0.22	0.23	0.26	0.28	0.29	0.30
30	0.12	0.12	0.15	0.18	0.20	0.21	0.23	0.24	0.26	0.27	0.29	0.30	0.32	0.33	0.32	0.35	0.39	0.42	0.44	0.45
40	0.16	0.16	0.20	0.24	0.26	0.28	0.30	0.32	0.34	0.36	0.38	0.40	0.42	0.44	0.43	0.46	0.52	0.56	0.58	0.60
50	0.20	0.20	0.25	0.30	0.33	0.35	0.38	0.40	0.43	0.45	0.48	0.50	0.53	0.55	0.54	0.58	0.65	0.70	0.73	0.75
60	0.24	0.24	0.30	0.36	0.39	0.42	0.45	0.48	0.51	0.54	0.57	0.60	0.63	0.66	0.65	0.69	0.78	0.84	0.87	0.90

<sup>1</sup>Pipe length baseline temperature = 0°F. "Expansion of Carbon, Copper and Stainless Steel Pipe," *The Engineers' Toolbox*, www.engineeringtoolbox.com.

Figure 23: Coiled Expansion Loops and Offsets.

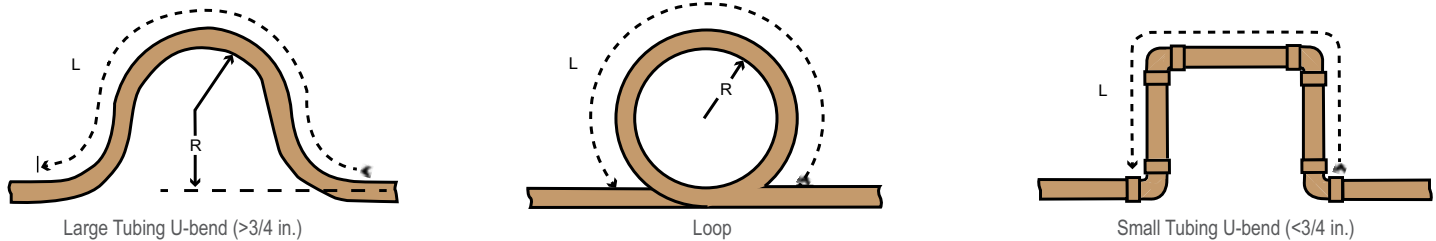

Table 19: Radii of Coiled Expansion Loops and Developed Lengths of Expansion Offsets.

Anticipated Linear Expansion (LE) (inches)		Nominal Tube Size (OD) inches			
		1/4	3/8	1/2	3/4
1/2	R <sup>1</sup>	6	7	8	9
	L <sup>2</sup>	38	44	50	59
1	R <sup>1</sup>	9	10	11	13
	L <sup>2</sup>	54	63	70	83
1-1/2	R <sup>1</sup>	11	12	14	16
	L <sup>2</sup>	66	77	86	101
2	R <sup>1</sup>	12	14	16	19
	L <sup>2</sup>	77	89	99	117
2-1/2	R <sup>1</sup>	14	16	18	21
	L <sup>2</sup>	86	99	111	131
3	R <sup>1</sup>	15	17	19	23
	L <sup>2</sup>	94	109	122	143
3-1/2	R <sup>1</sup>	16	19	21	25
	L <sup>2</sup>	102	117	131	155
4	R <sup>1</sup>	17	20	22	26
	L <sup>2</sup>	109	126	140	166

# GENERAL INSTALLATION GUIDELINES

## Refrigerant Piping

**MULTI F**  
**MULTI F MAX**

### Inserts and Pipe Supports

#### Inserts

An insert can be installed into a floor or beam before the concrete sets so that fittings such as ducts, pipes, or suspension bolts can be added at a later time. Decide where the inserts should be placed before support installation.

#### Pipe Supports

##### Note:

*The pipe system must be adequately supported to avoid pipe sagging. Sagging pipes become oil traps that lead to equipment malfunction.*

Pipe supports should never touch the pipe wall; supports should be installed outside (around) the primary pipe insulation jacket. Insulate the pipe before installing the supports. Pipe supports are field-provided and must meet local code. If local codes do not specify pipe support spacing, install pipe supports a maximum of five (5) feet on center for straight segments of pipe up to 3/4" outside diameter size.

Wherever the pipe changes direction, place a hanger within twelve (12) inches on one side and within twelve to nineteen (12 to 19) inches of the bend on the other side. Support piping at indoor units as shown. Support Y-branch fittings as shown.

Figure 24: Installing an Insert Into a Concrete Beam.

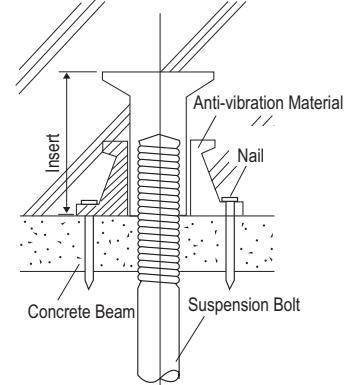

Figure 25: Pipe Hanger Details.

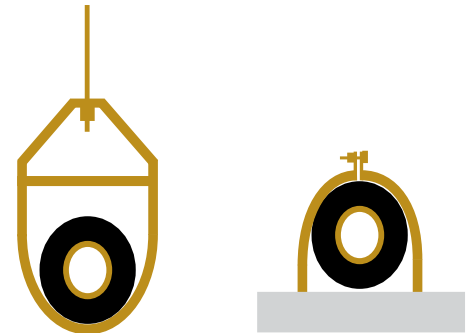

Figure 26: Typical Pipe Support Location—Change in Pipe Direction.

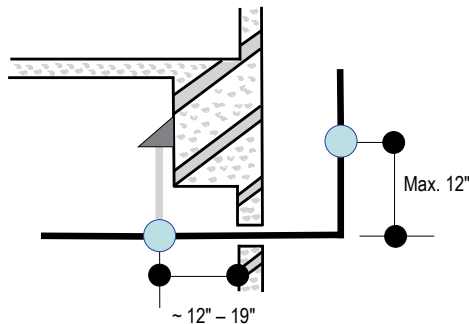

Figure 27: Pipe Support at Indoor Unit.

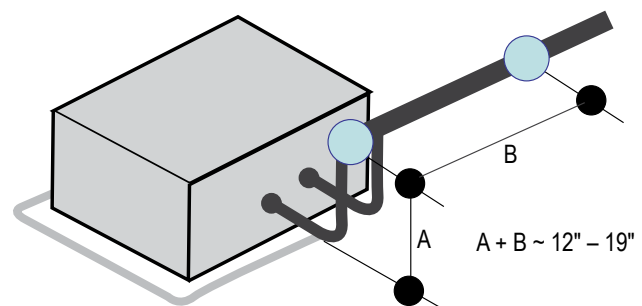
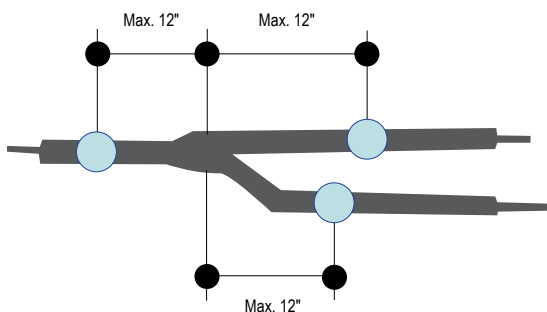

Figure 28: Pipe Support at Y-branch Fitting.



Examples of Supports

Figure 29: U-Bolt Support with Insulation.

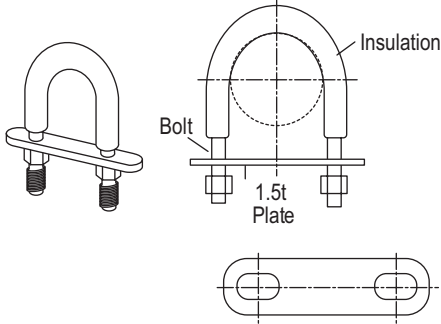

Figure 30: O-Ring Support with Insulation.

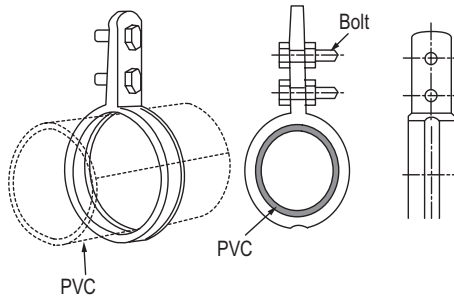
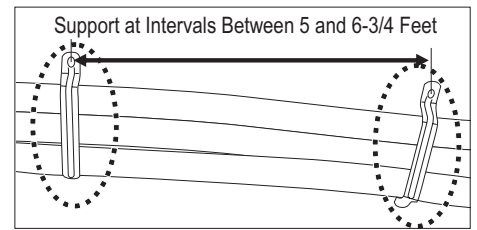

Figure 31: Saddle-Type Support.



**Note:**

⊗ Do not compress the insulation with the saddle-type support. If the insulation is compressed, it may tear open and allow condensation to generate during product operation.

Figure 32: U-Bolt Support with an Insulated Pipe.

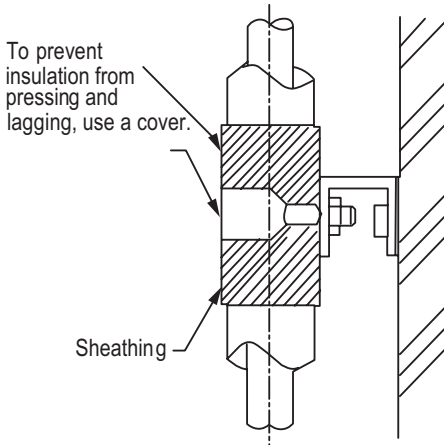

Figure 33: O-Ring Band Support with an Insulated Pipe.

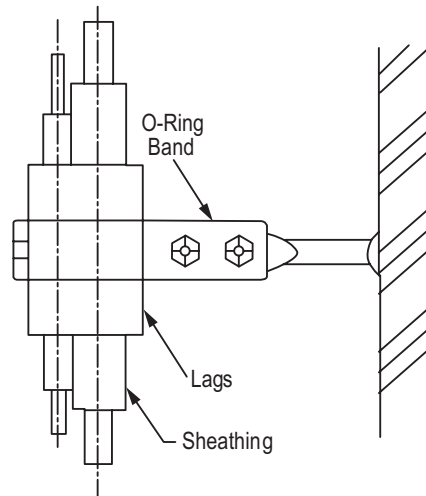

Figure 34: One-Point Down-Stop Support (>441 lbs.).

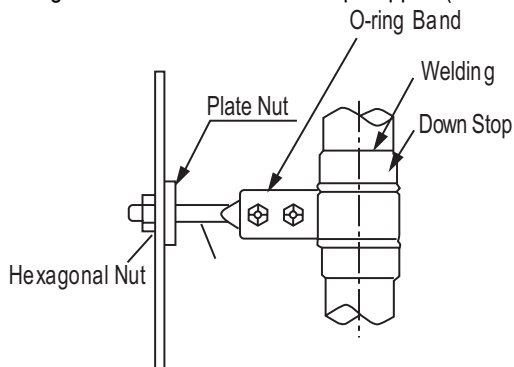
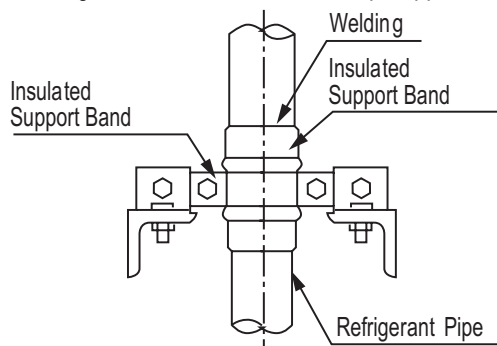

Figure 35: Two-Point Down-Stop Support.



### Pipe Sleeves at Penetrations

LG requires that all pipe penetrations through walls, floors, and pipes buried underground be routed through a properly insulated sleeve that is sufficiently sized to provide free movement of the pipe and does not compress the insulation. Route underground refrigerant pipe inside a protective sleeve to prevent insulation deterioration. Follow federal, state, and local regulations and codes when choosing a sleeve type.

#### Note:

Pipe diameter plus insulation thickness determines wall penetration diameter.

#### For example:

Diameter of Gas Piping:	1/2"
Diameter of Liquid Piping:	1/4"
Thickness of Gas Piping Insulation:	0.4" x 2
Thickness of Liquid Piping Insulation:	0.4" x 2
Surplus:	0.8"
Sleeve diameter (total):	3.1" minimum

Figure 36: Pipe Sleeve Options.

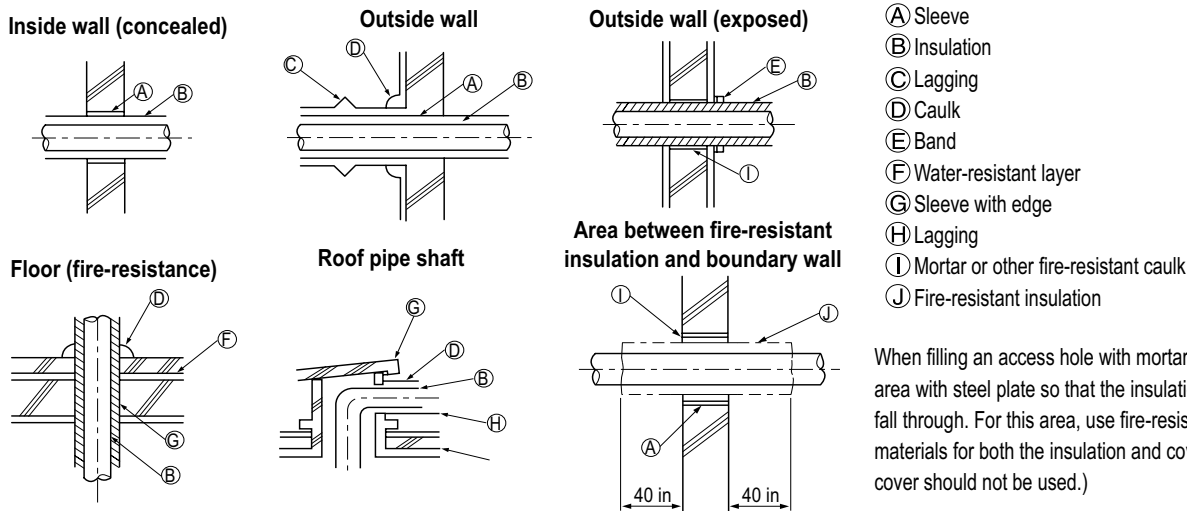

When filling an access hole with mortar, cover the area with steel plate so that the insulation will not fall through. For this area, use fire-resistant materials for both the insulation and cover. (Vinyl cover should not be used.)

### Underground Refrigerant Piping

Route refrigerant pipe installed underground inside a vapor tight protective sleeve to prevent insulation deterioration and water infiltration. Refrigerant pipe installed inside underground casing must be continuous without any joints. Underground refrigerant pipe must be located at a level below the frost line.

Table 20: Utility Conduit Sizes.

Liquid Pipe <sup>1</sup>	Vapor Pipe <sup>1</sup>			
	3/8 (1-1/8 <sup>2,3</sup> )	1/2 (2.0 <sup>2,5</sup> )	5/8 (2-1/8 <sup>2,5</sup> )	3/4 (2-1/4 <sup>2,5</sup> )
1/4 (1.0) <sup>3</sup>	4	4	4	4
3/8 (1-1/8) <sup>3</sup>	4	4	4	5

<sup>1</sup>OD pipe diameter in inches; Values in parenthesis ( ) indicate OD of pipe with insulation jacket.

<sup>2</sup>Diameter of pipe with insulation. Thickness of pipe insulation is typical. Actual required thickness may vary based on surrounding ambient conditions and should be calculated and specified by the design engineer.

<sup>3</sup>Insulation thickness (value in parenthesis) = 3/8 inch.

<sup>4</sup>Insulation thickness (value in parenthesis) = 1 inch.

<sup>5</sup>Insulation thickness (value in parenthesis) = 3/4 inch.

Figure 37: Typical Arrangement of Refrigerant Pipe and Cable(s) in a Utility Conduit.

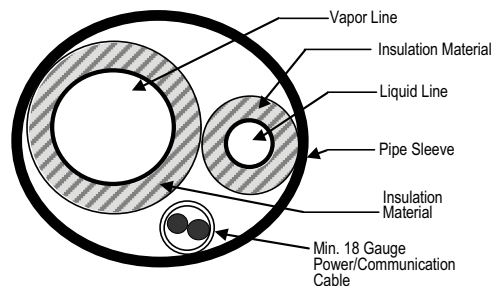

Figure 38: Underground Refrigerant Piping.



### Piping Materials and Handling

Pipes used for the refrigerant piping system must include the specified thickness, and the interior must be clean.

While handling and storing, do not bend or damage the pipes, and take care not to contaminate the interior with dust, moisture, etc. See Table 21 for care of piping.

Figure 39: Keep Piping Capped While Storing.

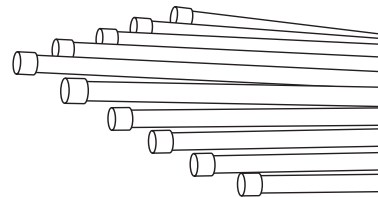
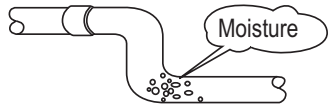

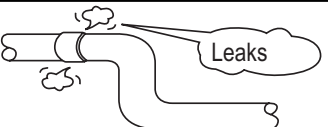

Table 21: Three Principles of Refrigerant Piping.

	Dry	Clean	Airtight
<b>Principles</b>	No moisture should be inside the piping.	No dust should be inside the piping.	No leaks should occur.
			
<b>Problems Caused</b>	<ul style="list-style-type: none"> <li>- Significant hydrolysis of refrigerant oil.</li> <li>- Refrigerant oil degradation.</li> <li>- Poor insulation of the compressor.</li> <li>- System does not operate properly.</li> <li>- EEVs, capillary tubes are clogged.</li> </ul>	<ul style="list-style-type: none"> <li>- Refrigerant oil degradation.</li> <li>- Poor insulation of the compressor.</li> <li>- System does not operate properly.</li> <li>- EEVs and capillary tubes become clogged.</li> </ul>	<ul style="list-style-type: none"> <li>- Refrigerant gas leaks / shortages.</li> <li>- Refrigerant oil degradation.</li> <li>- Poor insulation of the compressor.</li> <li>- System does not operate properly.</li> </ul>
<b>Solutions</b>	<ul style="list-style-type: none"> <li>- Remove moisture from the piping.</li> <li>- Piping ends should remain capped until connections are complete.</li> <li>- Do not install piping on a rainy day.</li> <li>- Connect piping properly at the unit's side.</li> <li>- Remove caps only after the piping is cut, the burrs are removed, and after passing the piping through the walls.</li> <li>- Evacuate system to a minimum of 500 microns and ensure the vacuum holds at that level for 24 hours.</li> </ul>	<ul style="list-style-type: none"> <li>- Remove dust from the piping.</li> <li>- Piping ends should remain capped until connections are complete.</li> <li>- Connect piping properly at the side of the unit.</li> <li>- Remove caps only after the piping is cut and burrs are removed.</li> <li>- Retain the cap on the piping when passing it through walls, etc.</li> </ul>	<ul style="list-style-type: none"> <li>- Test system for air tightness.</li> <li>- Perform brazing procedures that comply with all applicable standards.</li> <li>- Perform flaring procedures that comply with all applicable standards.</li> <li>- Perform flanging procedures that comply with all applicable standards.</li> <li>- Ensure that refrigerant lines are pressure tested to 550 psig.</li> </ul>

### Piping Preparation

#### ⚠ WARNING

- Do not allow the refrigerant to leak during brazing; if refrigerant combusts, it generates a toxic gas which can cause physical injury or death.
- Do not braze in an enclosed location, and always test for gas leaks before / after brazing. Gas leaks can cause physical injury or death.
- After brazing, check for refrigerant gas leaks. Refrigerant gas leaks can cause physical injury or death.
- When selecting flare fittings, always use a 45° fitting rated for use with high pressure refrigerant R410A. Failure to do so may result in refrigerant leaks which in turn could result in personal injuries or death from oxygen depletion. Selected fittings must also comply with local, state, or federal standards.

#### Note:

1. If piping becomes kinked due to excessive bending, do not use the pipe.
2. Braze the pipes to the service valve pipe stub of the outdoor unit.

#### Creating a Flare Fitting

#### Note:

One of the main causes of refrigerant leaks is defective flared connections. Be sure to properly form the flare connections.

1. Cut the pipe to length.
  - Measure the distance between the indoor unit and the outdoor unit.
  - Cut the pipes a little longer than measured distance.
  - Cut the cable 4.9 ft longer than the pipe length.
- 2A. Remove the burrs.
  - Completely remove all burrs from pipe ends.
  - When removing burrs, point the end of the copper pipe down to avoid introducing foreign materials in the pipe.
- 2B. Slide the flare nut onto the copper tube.
3. Flaring the pipe end.
  - Use the proper size flaring tool to finish flared connections as shown.
  - Refer to the diagram in step 3 of Figure 40 and the dimensions in Table 22 for positioning the pipe in the flaring tool.
  - ALWAYS create a 45° flare when working with R410A. See Warning on this page.
4. Carefully inspect the flared pipe end.
  - Compare the flare with the illustration in step 4 of Figure 40.
  - If the flare is defective, cut it off and re-do procedure.
  - If flare looks good, blow clean the pipe with dry nitrogen.

Figure 40: Creating a Flare Fitting.

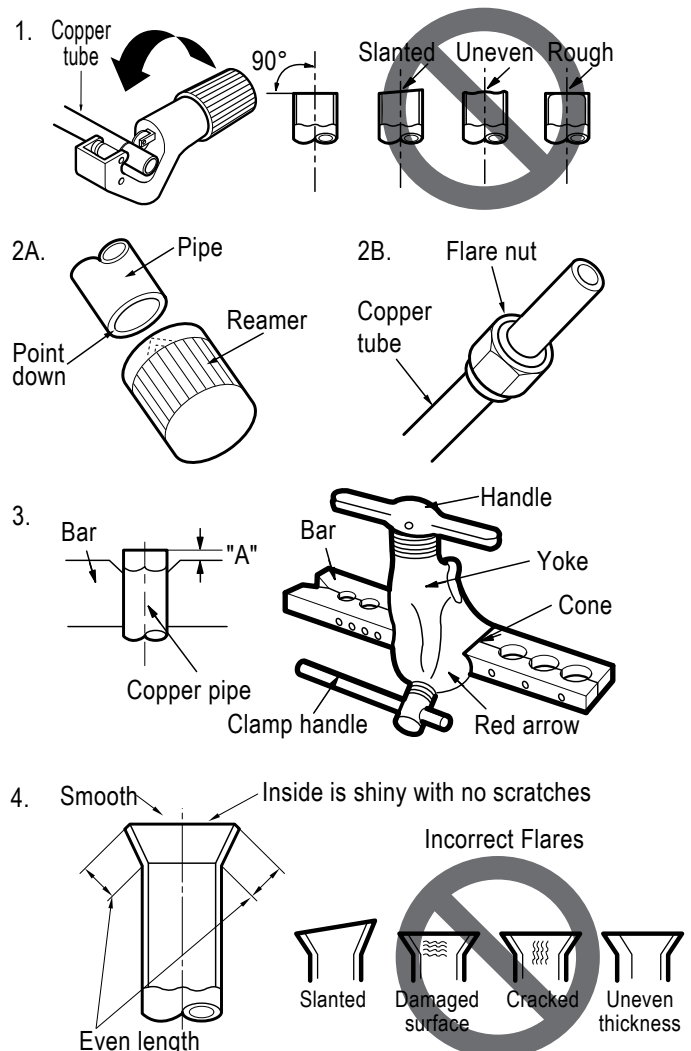

Table 22: Flare "A" Measurement.

Pipe Outside Diameter (inch)	"A" Measurement (inch)
1/4	0.04 – 0.5
3/8	0.06 – 0.7
1/2	0.06 – 0.7
5/8	0.06 – 0.7
3/4	0.07 – 0.8

**Tightening the Flare**

**Note:**

⊘ Do not use polyolyester (POE) or any other type of mineral oil as a thread lubricant. These lubricants are not compatible with PVE oil used in this system and create oil sludge leading to equipment damage and system malfunction.

1. When connecting the flare nuts, coat the flare (inside and outside) with polyvinyl ether (PVE) refrigeration oil only.
2. Align the center of the piping sections and tighten the flare nut by hand.
3. Tighten the flare nut with a torque wrench and a backup wrench until a click is heard.
4. Wrap insulation around the connection.
5. If it is necessary to loosen the flare nuts, always use two wrenches to do so.

Table 23: Tightening Torque for Flare Nuts.

Pipe size (Inches O.D.)	Tightening torque (ft-lbs)	Width of the flare (A [inches])
1/4Ø	13.9 - 18	1/8
3/8Ø	24.5 - 30.3	1/8
1/2Ø	39.7 - 47.7	1/8
5/8Ø	45.5 - 59.2	1/16

**Multi F Outdoor Unit to Indoor Unit Piping Connections**

**Avoid Pipe Damage**

- When routing field-provided piping, avoid damaging the outdoor unit from excessive vibration.
- Correctly route the piping so it does not make contact with mounting bolts. Allow room for field installation.
- Properly insulate the liquid and gas lines separately up to the point of connection at the unit frame.
- See table below for Multi F outdoor unit connection types.

Table 24: Outdoor Unit Piping Connections.

Outdoor Unit Piping Connections	LMU18CHV	LMU24CHV	LMU30CHV	LMU36CHV
Liquid Line Connection (in., OD) x Qty.	1/4 x 2	1/4 x 3	1/4 x 3	1/4 x 4
Vapor Line Connection (in., OD) x Qty.	3/8 x 2	3/8 x 3	3/8 x 3	3/8 x 4

Table 25: Ceiling Cassette Indoor Unit Pipe Sizes.

Indoor Unit Capacity	Vapor Line Size (in., OD)	Liquid Line Size (in., OD)
7,000 Btu/h	Ø3/8	Ø1/4
9,000 Btu/h		
12,000 Btu/h		
18,000 Btu/h	Ø1/2	

Table 26: Ceiling Cassette Indoor Unit Piping Connections.

Indoor Unit Capacity	Vapor Line Connection (in., OD)	Liquid Line Connection (in., OD)
7,000 Btu/h	Ø3/8	Ø1/4
9,000 Btu/h		
12,000 Btu/h		
18,000 Btu/h	Ø1/2	

Figure 41: Multi F Refrigerant Pipe Connections (LMU36CHV shown as example).

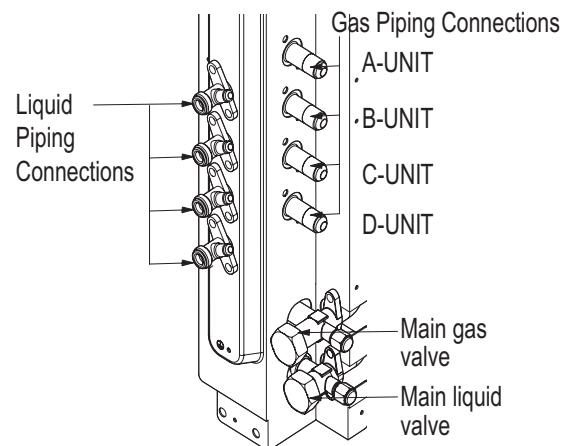

# PIPING CONNECTIONS

IDU to ODU

**MULTI F**  
**MULTI F MAX**

## Multi F Outdoor Unit to Indoor Unit Piping Connections, continued.

Connection sockets (included as a factory-supplied accessory with the indoor units) may need to be used when piping the indoor units to the outdoor unit.

Table 27: Connection Socket Dimensions.

Indoor Unit Capacity	Vapor (in., OD)		Liquid (in., OD)	
	A	B	A	B
18,000 Btu/h	Ø3/8 → Ø1/2		N/A	

### Using the Connection Socket

1. Align the center of the piping sections and tighten the flare nut by hand.
2. Tighten the flare nut with a torque wrench, using the arrows on the wrench as a guide, until a click is heard.

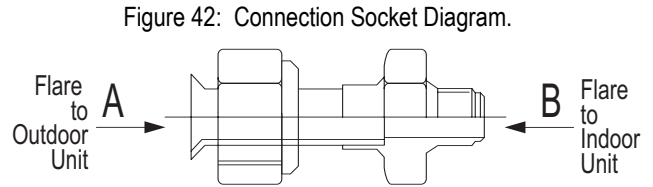
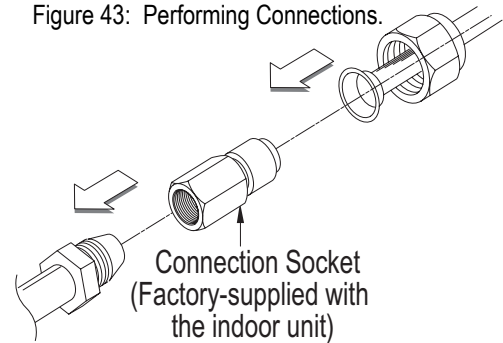

Figure 43: Performing Connections.



## Multi F MAX Outdoor Unit System Piping Connections

### Note:

#### Avoid Pipe Damage

- When routing field-provided piping, avoid damaging the outdoor unit from excessive vibration.
- Properly insulate the liquid and gas lines separately up to the point of connection at the unit frame.
- See table below for Multi F MAX outdoor unit connection types.

 Correctly route the piping so it does not make contact with mounting bolts. Allow room for field installation.

Table 28: Outdoor Unit Piping Connections.

Outdoor Unit Piping Connections	LMU480HV, LMU540HV, and LMU600HV
Liquid Line Connection (in., OD) x Qty.	3/8 x 1
Vapor Line Connection (in., OD) x Qty.	3/4 x 1

### Branch Distribution to Indoor Unit Piping Connections

- Install indoor unit liquid and vapor refrigerant pipes (and connection wiring) to the appropriate branch distribution ports.
- Clearly note on the indoor unit's refrigerant piping (liquid, vapor) which branch distribution port it is connected to (A, B, C, D).

Table 29: Branch Distribution Unit Piping Connections.

Branch Distribution Unit	PMBD3620	PMBD3630	PMBD3640	PMBD3641
<b>Piping Connections to Outdoor Unit</b>				
Liquid (in., OD) x Qty.	Ø3/8 x 1			
Vapor (in., OD) x Qty.	Ø3/4 x 1			
<b>Piping Connections to Indoor Units</b>				
Liquid (in., OD) x Qty.	Ø1/4 x 2	Ø1/4 x 3	Ø1/4 x 4	Ø1/4 x 3, Ø3/8 x 1
Vapor (in., OD) x Qty.	Ø3/8 x 2	Ø3/8 x 3	Ø3/8 x 4	Ø3/8 x 3, Ø5/8 x 1

Figure 44: Branch Distribution Ports to Indoor Units.

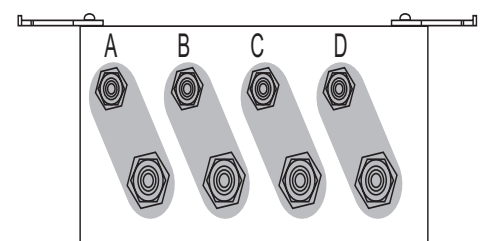

**Multi F MAX Outdoor Unit System Piping Connections, continued.**

Table 30: Ceiling Cassette Indoor Unit Pipe Sizes.

Indoor Unit Capacity	Vapor Line Piping Size (in., OD)	Liquid Line Piping Size (in., OD)
7,000 Btu/h	Ø3/8	Ø1/4
9,000 Btu/h		
12,000 Btu/h		
18,000 Btu/h	Ø1/2	

Table 31: Ceiling Cassette Indoor Unit Piping Connections.

Indoor Unit Capacity	Vapor Line Conn. (in., OD)	Liquid Line Conn. (in., OD)
7,000 Btu/h	Ø3/8	Ø1/4
9,000 Btu/h		
12,000 Btu/h		
18,000 Btu/h	Ø1/2	Ø1/4

Connection sockets (included as a factory-supplied accessory with the indoor units) may need to be used when piping the indoor units to the branch distribution unit.

Table 32: Connection Socket Dimensions.

Indoor Unit Capacity	Vapor (in., OD)		Liquid (in., OD)	
	A	B	A	B
18,000 Btu/h	Ø3/8 → Ø1/2		N/A	

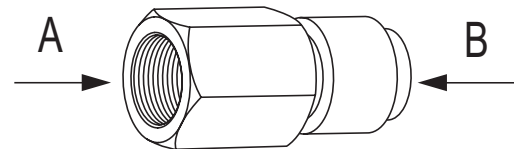

Connection Socket

Figure 46: Possible Outdoor Unit or Branch Distribution Unit (Multi F MAX only) to Indoor Unit Connections.

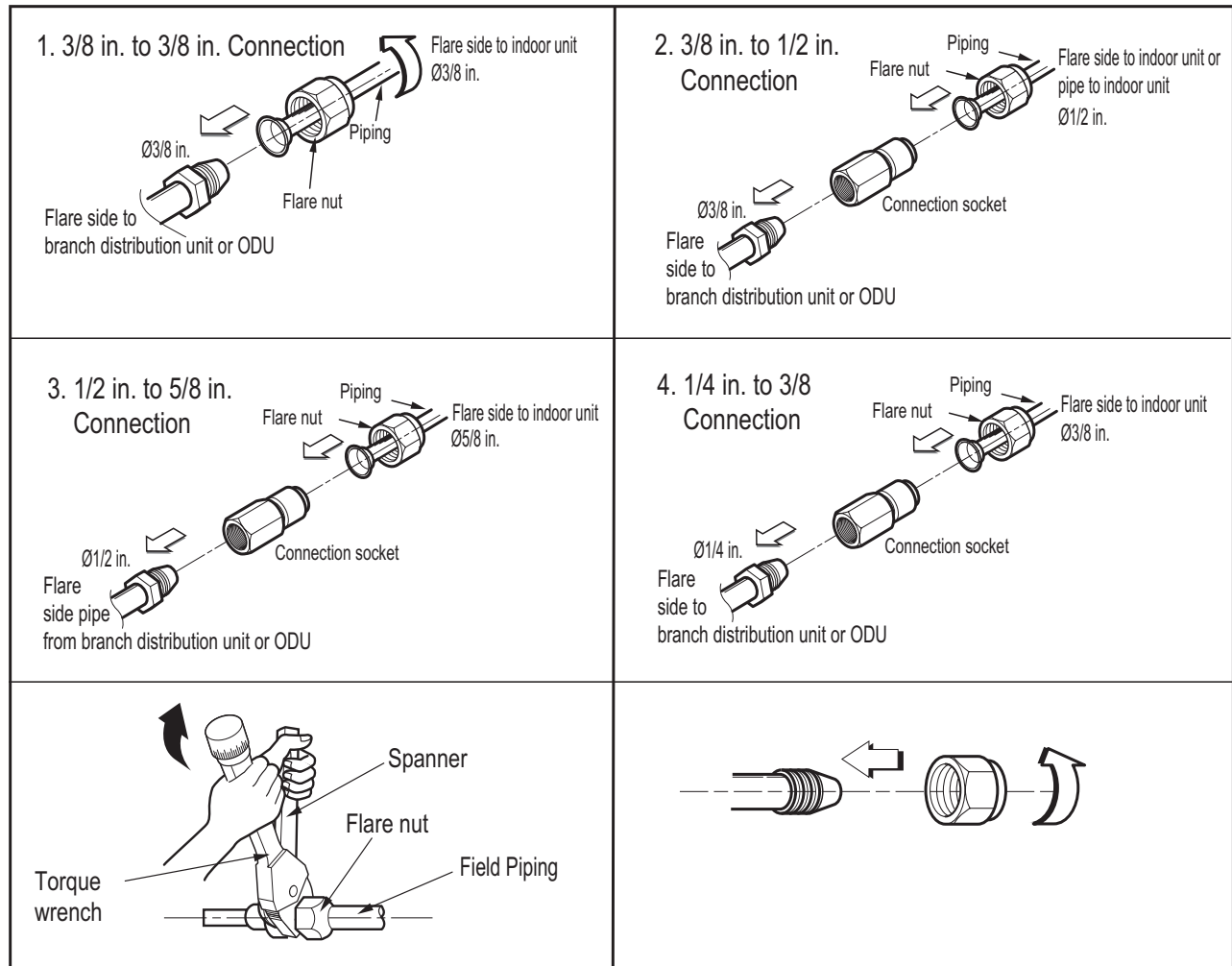

## Refrigerant Safety

### ⚠ WARNING

Verify the maximum refrigerant concentration level in the space where the indoor unit will be installed meets the concentration limit for the application.

ASHRAE Standards 15-2010 and 34-2010 offer guidelines that address refrigerant safety and the maximum allowable concentration of refrigerant in an occupied space. Refrigerant will dissipate into the atmosphere, but a certain volume of air is required for this to occur safely. For R410A refrigerant, the maximum allowable concentration of refrigerant is twenty-six (26) lbs. per 1,000 cubic feet of an occupied space. Buildings with twenty-four (24) hour occupancy allow half of that concentration.<sup>1</sup>

ASHRAE Standards 15 and 34 assume that if a system develops a leak, its entire refrigerant charge will dump into the area where the leak occurs. To meet ASHRAE Standards 15 and 34, calculate the refrigerant concentration that may occur in the smallest room volume on the system, and compare the results to the maximum allowable concentration number.<sup>1</sup> Also consult state and local codes in regards to refrigerant safety.

<sup>1</sup>Information about ASHRAE Standard 15-2010/34-2010 and addenda current as of the date of this publication.

## Brazing

### Note:

It is imperative to keep the piping system free of contaminants and debris such as copper burrs, slag, or carbon dust during installation.

- All joints are brazed in the field. Multi F refrigeration system components contain very small capillary tubes, small orifices, electronic expansion valves, oil separators, and heat exchangers that can easily become blocked. Proper system operation depends on the installer using best practices and utmost care while assembling the piping system.
  - Store pipe stock in a dry place and keep stored pipe capped and clean.
  - Purge all pipe sections clean with dry nitrogen prior to assembly.
- Proper system operation depends on the installer using best practices and the utmost care while assembling the piping system.
  - Use adapters to assemble different sizes of pipe.
  - Always use a non-oxidizing material for brazing. ⚠ Do not use flux, soft solder, or anti-oxidant agents. If the proper material is not used, oxidized film may accumulate and clog or damage the compressors. Flux can harm the copper piping or refrigerant oil.
  - Use a tubing cutter. ⚠ Do not use a saw to cut pipe. De-bur and clean all cuts before assembly.
- Brazing joints:
  - Use a dry nitrogen purge operating at a minimum pressure of three (3) psig and maintain a steady flow.
  - Use a 15% silver phosphorous copper brazing alloy to avoid overheating and produce good flow.
  - Protect isolation valves (if present), electronic expansion valves, and other heat-sensitive control components from excessive heat with a wet rag or heat barrier spray.

Figure 47: Using Nitrogen Gas During Brazing.

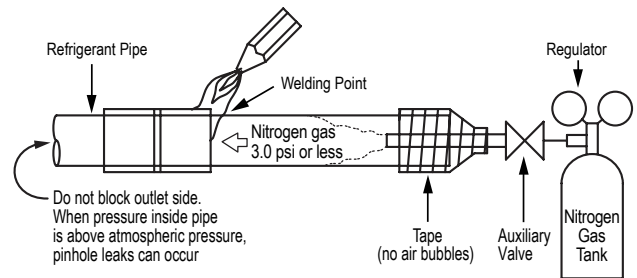

## Refrigerant Piping System Insulation

All refrigerant piping including Y-branch connections, field-provided isolation ball valves, service valves, and elbows must be properly and completely insulated using closed cell pipe insulation (up to the indoor unit piping connections). To prevent heat loss/heat gain through the refrigerant piping, all refrigerant piping including liquid lines and vapor lines must be insulated separately. Insulation must be a minimum 1/2" thick, and thickness may need to be increased based on ambient conditions and local codes. Table 33 lists minimum wall thickness requirements for Ethylene Propylene Diene Methylene (EPDM) insulation.

Inside the outdoor unit, maximum pipe temperature is 248°F and minimum pipe temperature is -40°F. For field insulation of refrigerant piping between outdoor units and indoor units, consider the following pipe temperature ranges for an operating heat pump system:

- Heating mode refrigerant temperature ranges: Liquid 75-118°F; High Pressure Vapor 95-220°F
- Cooling mode refrigerant temperature ranges: Liquid 75-118°F; Low Pressure Vapor 40-90°F

**Note:**

Follow locals codes when selecting EPDM insulation wall thickness. Thickness in Table 33 is based on heat conductivity of 0.61 Btu/in/h/ft<sup>2</sup>/°F.

Table 33: Insulation Guidelines for Typical and Special Circumstances.

Classification		Air-conditioned location		Non-air conditioned location	
		1. Typical location	2. Special location	3. Typical location	4. Special location
Liquid pipe	ø1/4 inches	1/2 inches	1/2 inches	1/2 inches	1/2 inches
	ø3/8 inches				
	≥ø1/2 inches				
Vapor pipe	ø3/8 inches	1/2 inches	3/4 inches	3/4 inches	1 inch
	ø1/2 inches				
	ø5/8 inches				
	ø3/4 inches				

**1. Air-conditioned, Typical location**

- When piping passes through an indoor area where the indoor unit operates, such as an apartment, classroom, office, mall, hospital, etc.

**2. Air-conditioned, Special location**

- When the location is air conditioned, but has severe temp/humidity difference due to high ceilings, such as a church, auditorium, theater, etc.
- When the location is air conditioned, but internal temperature/humidity are high, such as a bathroom, swimming pool, locker room, etc.

**3. Non-air conditioned, Typical location**

- When piping passes through an indoor area where the indoor unit does not operate, such as a hallway, dormitory, or school, etc.

**4. Non-air conditioned, Special location (when both conditions listed below are present)**

- When piping passes through an indoor area where the indoor unit does not operate.
- When the humidity is high and there is no air flow in the location where the piping is installed.

**⚠ WARNING**

Ensure all refrigerant piping is insulated. Any exposed piping will cause burns if touched.

**Note:**

Any exposed piping may generate condensate that may damage walls, etc.; sufficiently insulate all cold surfaces to prevent moisture from forming.

Overlap the insulation at the connection of the field-installed piping and the indoor unit. Tape together so that no gaps exist, and secure insulation to the rear piping housing with vinyl tape.

Ensure insulation material fits snugly against the refrigeration pipe with no air space between the pipe surface and the surrounding insulation.

Protect insulation inside hangers and supports with a second insulation layer. Ensure insulation on all pipe passing through pipe hangers, inside conduit, and/or sleeves is not compressed.

Glue all insulation joints with no air gaps. Be sure insulation material fits snugly against the refrigeration pipe with no air space between it and the pipe. All pipe insulation exposed to the sun and outdoor elements must be properly protected with PVC, aluminum vapor barrier, or alternatively placed in a weather-resistant enclosure such as a pipe rack with a top cover; and must meet local codes. Pay special attention to insulating the pipes installed in a ceiling plenum.

Figure 48: Typical Refrigerant Line Flare Fitting Insulation Detail.

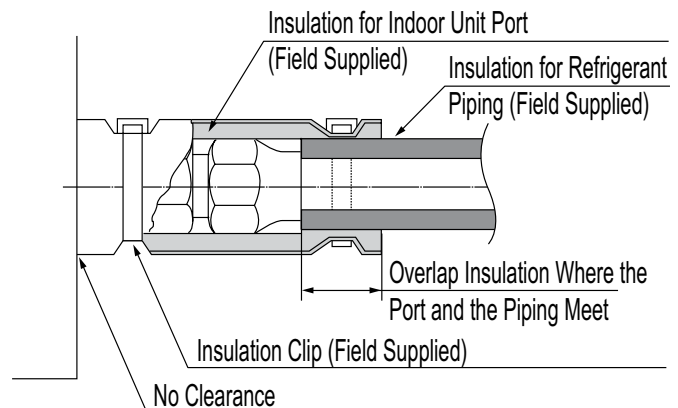

### **⚠ WARNING**

- All power wiring and communication cable installation must be performed by authorized service providers working in accordance with local, state, and National Electrical Code regulations related to electrical equipment and wiring, and following the instructions in this manual.
- Be sure that main power to the unit is completely off before proceeding. Follow all safety and warning information outlined at the beginning of this manual. Failure to do so may cause electric shock and bodily injury.
- Familiarize yourself with the location of the circuit breaker. Be sure that a circuit breaker or some other emergency power cutoff device is in place before any power wiring is done to the system. Failure to do so may cause bodily injury or death.
- ⓧ Never touch any power lines or live cables before all power is cutoff to the system. To do so, may cause bodily injury or death.
- Undersized wiring may lead to unacceptable voltage at the unit and may cause unit malfunction and be a fire hazard.
- Properly ground the outdoor, indoor, and branch distribution (Multi F MAX systems only) units. Ground wiring is required to prevent accidental electrical shock during current leakage.
- Ground wiring must always be installed by a qualified technician.
- Install appropriately sized breakers / fuses / overcurrent protection switches and wiring in accordance with local, state, and National Electrical Code regulations related to electrical equipment and wiring, and following the instructions in this manual. Using an oversized breaker or fuse may result in electric shock, physical injury or death.
- ⓧ Do not connect ground wire to refrigerant, gas, or water piping; to lightning rods; to telephone ground wiring; or to the building plumbing system. Failure to properly provide a National Electrical Code-approved earth ground can result in electric shock, physical injury or death.

### **Note:**

- Consider ambient conditions (temperature, direct sunlight, inclement weather, etc.) when selecting, installing, and connecting the power wiring.
- Properly ground the outdoor, indoor, and branch distribution (Multi F MAX systems only) units. Improperly ground wire can cause communication problems from electrical noise and motor current leakage. Ground wiring must always be installed by a qualified technician.
- If the system operates in reversed phase, it may damage the compressors and other components.
- If there is a possibility of reversed phase, phase loss, momentary blackout, or the power goes on and off while the system is operating, install a field-supplied phase loss protection circuit.
- Install appropriately sized breakers / fuses / overcurrent protection switches and wiring in accordance with local, state, and National Electrical Code regulations related to electrical equipment and wiring, and following the instructions in this manual. Using an oversized breaker or fuse may result in equipment malfunction and property damage.
- ⓧ Do not connect ground wire to refrigerant, gas, or water piping; to lightning rods; to telephone ground wiring; or to the building plumbing system. Failure to properly provide a National Electrical Code-approved earth ground can result in property damage and equipment malfunction.
- ⓧ Do not operate the air conditioning system until the refrigerant piping installation is complete. Operating the system before refrigerant piping is finalized may damage the compressor.
- Use ring terminals to attach the wiring. Verify that all power wiring and communications cable terminals are securely attached. Ensure enough slack is included in the wiring and cables to avoid damaging the connections.
- Use a conduit to protect the power wiring.

## **Multi F / Multi F MAX System Power Wiring and Communications Cable**

For both Multi F and Multi F MAX systems, line voltage is wired to the outdoor unit only. The outdoor unit will supply power to the branch distribution units (Multi F MAX systems only) and the indoor units through the power wiring / communications cable.

**Power Supply / Power Wiring Specifications**

**Note:**

- Multi F and Multi F MAX systems operate at 1Ø, 208-230V, 60Hz.
- Power supply, wire type and size should be selected based on National Electrical Code and local codes. Maximum allowable voltage fluctuation ±10% or nameplate rated value.
- Properly ground the outdoor units per National Electrical Code and local codes.
- For power to the outdoor units, use field-supplied copper wiring that is solid or stranded, and shielded with the wires separately insulated.
- Ground wire should be longer than the common power / communication wires.
- Connect the wiring firmly so the wires cannot be easily pulled out.
- Refer to the inside of the chassis cover for circuit and terminal block diagrams for your model unit.
- Always match color codes of each wire and follow wiring diagram.

**General Communication Cable Specifications**

- Multi F Systems: All power wiring / communication cable to be minimum 18 AWG from the outdoor unit to the indoor unit, stranded, shielded or unshielded (if shielded, it must be grounded to the chassis of the outdoor unit only), and must comply with applicable local and national codes.
- Multi F MAX Systems: All power wiring / communication cable to be minimum 16 AWG from the outdoor unit to the BD unit, and 18 AWG from the BD unit to the indoor unit, stranded, shielded or unshielded (if shielded, it must be grounded to the chassis of the outdoor unit only), and must comply with applicable local and national codes.
- For power / communication wires between the Multi F and Multi F MAX outdoor units and the indoor units / BD units (Multi F MAX systems only), use a four (4) conductor, stranded, shielded or unshielded wire. If shielded, the wire must be grounded to the chassis at the outdoor unit only.
- Insulation material as required by local code.
- Rated for continuous exposure of temperatures up to 140°F.
- Firmly attach the cable; provide slack but secure in a way to prevent external forces from being imparted on the terminal block.
- Wiring should be completed without splices.

Figure 49: Multi F / Multi F MAX Outdoor and Indoor / Branch Distribution Unit Wiring and Communications Cable Diagram.

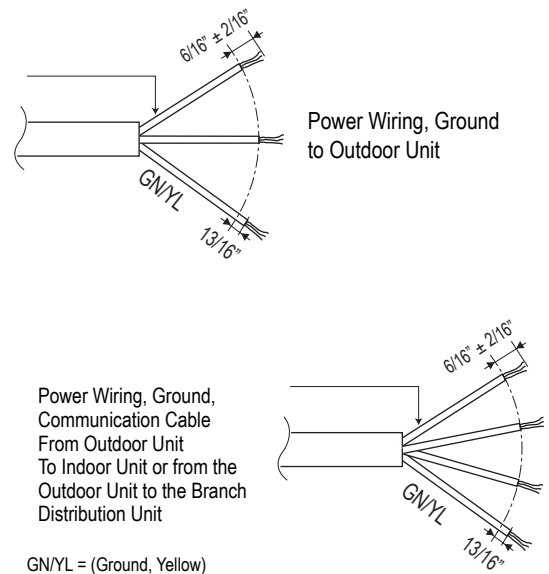

Figure 50: Close up of a Typical Ring Terminal.

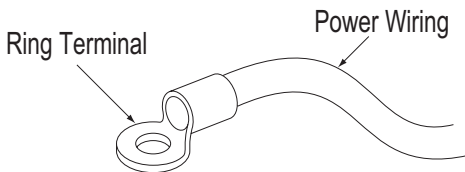
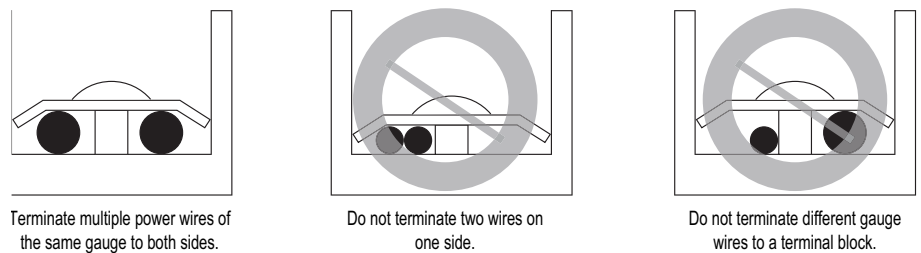

Figure 51: Proper and Improper Power Wiring Connections.



**⚠ WARNING**

If power wires are not properly terminated and firmly attached, there is risk of fire, electric shock, and physical injury or death.

### Note:

- Always verify the communication cable is connected to a communications terminal. ⚠ Never apply line voltage power to the communication cable connection. If contact is made, the PCBs may be damaged.
- Always include some allowance in the wiring length when terminating. Provide some slack to facilitate removing the electrical panels while servicing.
- The shield of the communications cable connecting the outdoor unit to the indoor units should be grounded only to the outdoor unit frame.
- Tie the shield of each cable segment together using a wire nut at the indoor unit. Maintain polarity throughout the communication network.
- Position the incoming power to the outdoor unit away from the power / communications cables from the outdoor unit to the indoor unit / branch distribution unit (Multi F MAX systems only).
- ⚠ Never use a common multiple-core communications cable. Each communications bus shall be provided a separate cable (i.e., between outdoor unit and indoor unit).
- ⚠ Never ground the shield of the communications cable to the indoor unit frame or other grounded entities of the building. Ground the communications cable shield only at the outdoor unit. Improperly grounding this cable can cause communications errors.

## Controller Options

Refer to the table at bottom right as to which remote controller model is used for each indoor unit. After all wiring is connected to the indoor and outdoor units, be sure to test the accompanying remote controllers for performance. As always, follow all safety warnings and notes when operating the units using the remote controller. Additionally, all of the Multi F / Multi F Max outdoor models can use the following controllers when accompanied with the PI 485 VNet Accessory:

- AC Smart
- ACP
- BACnet®
- LonWorks®
- LGMV

Table 34: Multi F Cassette Wireless Controller Model.

Wireless Controller Model
AKB73757604

BACnet® is a registered trademark of ASHRAE. LonWorks® is a registered trademark of Echelon Corporation.

\*Wireless Handheld Controller for the four-way ceiling cassette indoor units is also referenced by Model No. PQWRHQ0FDB.

## Power Wiring / Communications Cable Installation Guidelines

- These instructions are for the indoor unit only. For outdoor unit wiring, refer to the outdoor unit installation manual.
- Confirm power source specifications.
- Confirm that the electrical capacity is sufficient.
- Starting current must be maintained  $\pm 10$  percent of the rated current marked on the outdoor unit name plate.
- Confirm cable thickness specifications.
- It is recommended that a circuit breaker is installed, especially if conditions could become wet or moist.
- Include a disconnect in the power wiring system. Add an air gap contact separation of at least 1/8 inch in each active (phase) conductor.
- A voltage drop may cause the following problems:
  1. Magnetic switch vibration, fuse breaks, or disturbance to the normal function of an overload protection device.
  2. Compressor will not receive the proper starting current.

The general guidelines for connecting electrical and communication cables are similar for all ceiling cassette indoor units. The electrical connections procedure includes a wiring diagram for the ceiling cassette indoor unit. It is recommended that power wiring / communications cable installation be performed before decorative grille kit (required; sold separately) installation.

**⚠ WARNING**

- Be sure that main power to the unit is completely off before beginning this procedure. Electric shock can cause severe physical injury or death.
- Follow all safety and warning information outlined at the beginning and throughout this manual. Failure to do so may cause bodily injury or death.
- Loose wiring may cause unit malfunction, or the terminal to overheat and catch fire, causing physical injury.

**Note:**

- Follow all safety and warning information outlined at the beginning and throughout this manual. Failure to do so, may cause unit failure.
- Ceiling cassette units require removing the control cover from the terminal block area. Control covers are attached with a phillips screw head.
- Connect the electrical cable to the indoor unit by connecting the wires to the terminals on the control board individually according to the outdoor unit connection. Be sure that the color of the wires at the outdoor unit / BD unit (Multi F MAX systems only) along with the terminal numbers are the same as those for the indoor unit. If wiring is not performed correctly, the system will malfunction.
- Terminal screws may become loose during transport. Properly tighten the terminal connections during installation.

**Connecting the Power Wiring and Communications Cable**

1. To access the terminal block, unscrew the control box cover and set it aside.
2. Insert the power wiring / communications cable from the outdoor unit or branch distribution unit (Multi F MAX systems only) through the sides of the indoor unit and control box. Pass the wiring through the designated access holes to prevent damage. To prevent electromagnetic interference and product malfunction, leave a space between the power wiring and communications cable outside of the indoor unit.
3. Connect each wire to its appropriate terminal on the indoor unit control board. Verify that the color and terminal numbers from the outdoor unit or branch distribution unit (Multi F MAX systems only) wiring match the color and terminal numbers on the indoor unit.
4. Neatly arrange power wiring / communications cable and secure with the appropriate cable restraint. When clamping, do not apply force to the wiring connections.
5. Firmly reattach the control box cover, do not catch the wiring in the electric box cover and make sure the cover firmly closes.
6. Fill in any gaps around the wiring access holes with sealant to prevent foreign particles from entering the indoor unit.

Figure 52: Power Wiring and Communications Cable Connection Access.

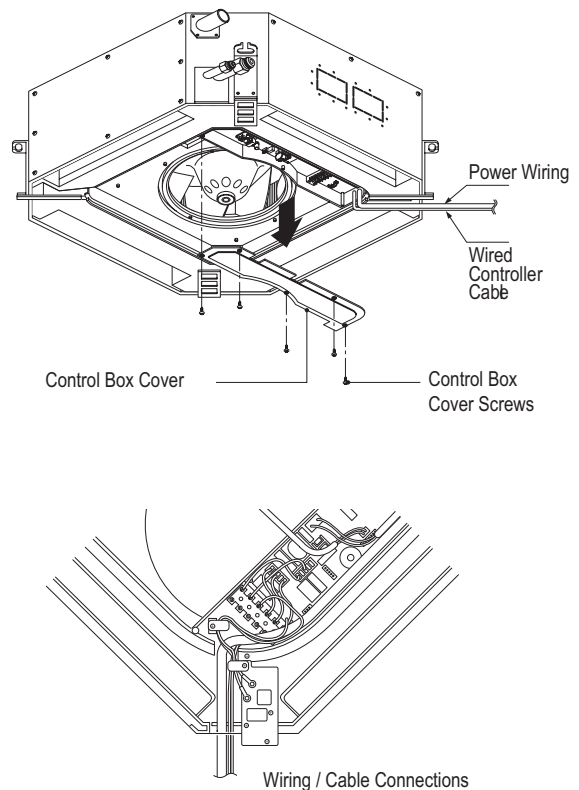

Figure 53: Simplified View of Indoor Unit to Outdoor Unit / Branch Distribution Unit Terminal Connections.

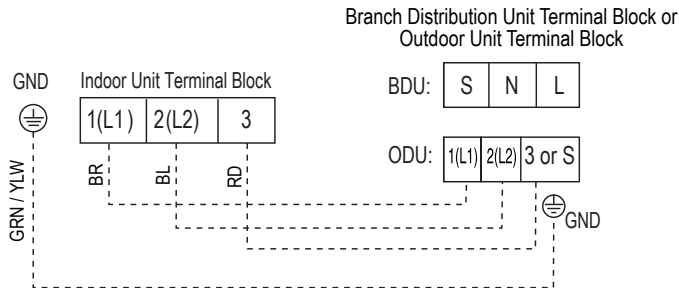
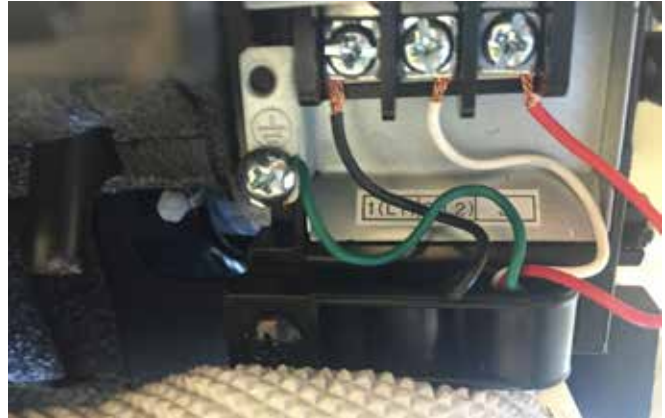

Figure 54: Typical Indoor Unit Terminal Block with Grounding Cable (Actual Appearance May Vary).



## Using a Conduit

1. Remove the rubber stopper on the indoor unit. Pass the power wiring / communications cable through the conduit, the conduit mounting plate, and to / through the control panel of the indoor unit.
2. Tighten the conduit and the conduit mounting plate together.
3. Connect the power wiring / communications cable to the indoor unit terminal block.
4. Screw the conduit mounting plate to the indoor unit.

### Note:

If the distance between the outdoor unit and indoor unit is greater than 131 feet, connect the power wiring and communications cable separately (i.e., a conduit cannot be used).

Figure 55: Using a Conduit.

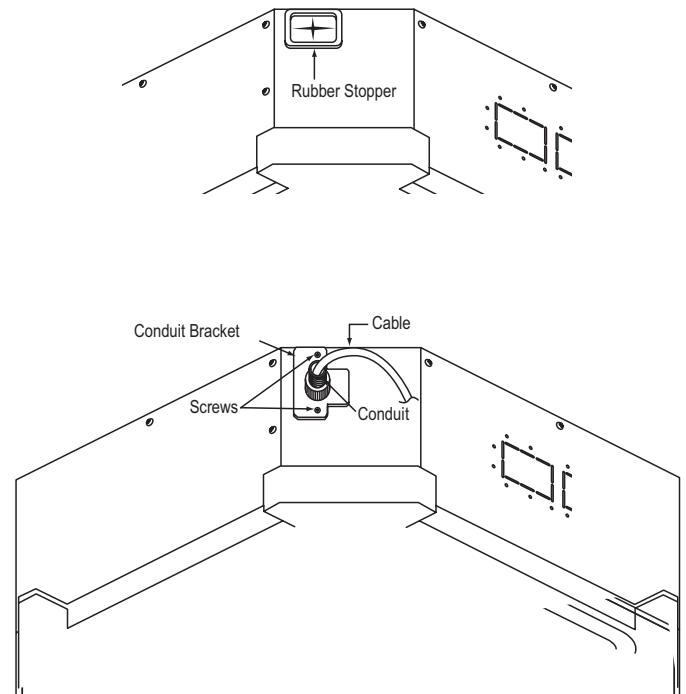

## PTVK430 Ventilation Kit

PTVK430 Ventilation Kit includes a flange for field-supplied ventilation pipe connection. Easily connects at the four-way ceiling-cassette three (3) inch fresh air knockout hole.

Figure 56: PTVK430 Ventilation Kit.

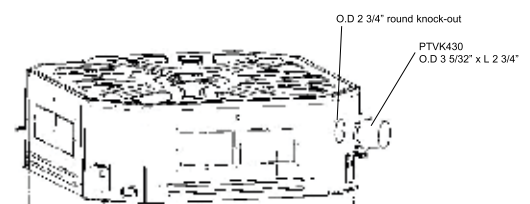

**Finalizing Indoor Unit Installation—Installing the Decoration Grille Kit**

**Note:**

Decoration grille (required; sold separately) must be installed properly; cool air will leak from any gaps found between the indoor unit frame and the decoration panel, which will cause condensation to generate.

1. Remove the packaging and paper template, take out air inlet grille from the front panel (1A), and then remove the corner covers of the panel (1B).
2. Attach the panel to the indoor frame by inserting the hooks as shown (2).
3. Attach two screws on diagonal corners of each panel, but do not tighten completely (3). The screws to attach the panel to the indoor unit frame are factory-provided and can be found in the shipping box.
4. Verify the panel is aligned with the ceiling. Adjust the height by using the hanging bolts as shown (4). Attach the other two screws, and then tighten all four screws until panel is secure.
5. Attach the corner covers (5).
6. Unscrew the two screws holding the control panel cover (6).
7. Connect the one display connector (CN-DISP) and the two vane control connectors (CN-VANE1, CN-VANE2) of the front panel to the indoor unit PCB (7).
8. Reattach the control box cover (8). Attach the filter grille retainer arm (inclusion dependent on model) on the front panel as shown (9). The filter grille retainer arm is supplied in the front panel shipping package.
9. Attach the other side of the filter grille retainer arm on the filter guide of the air inlet grille (10), then install the filter and the air inlet grille on the front panel (11).

Figure 57: Installing the Decoration Grille Kit.

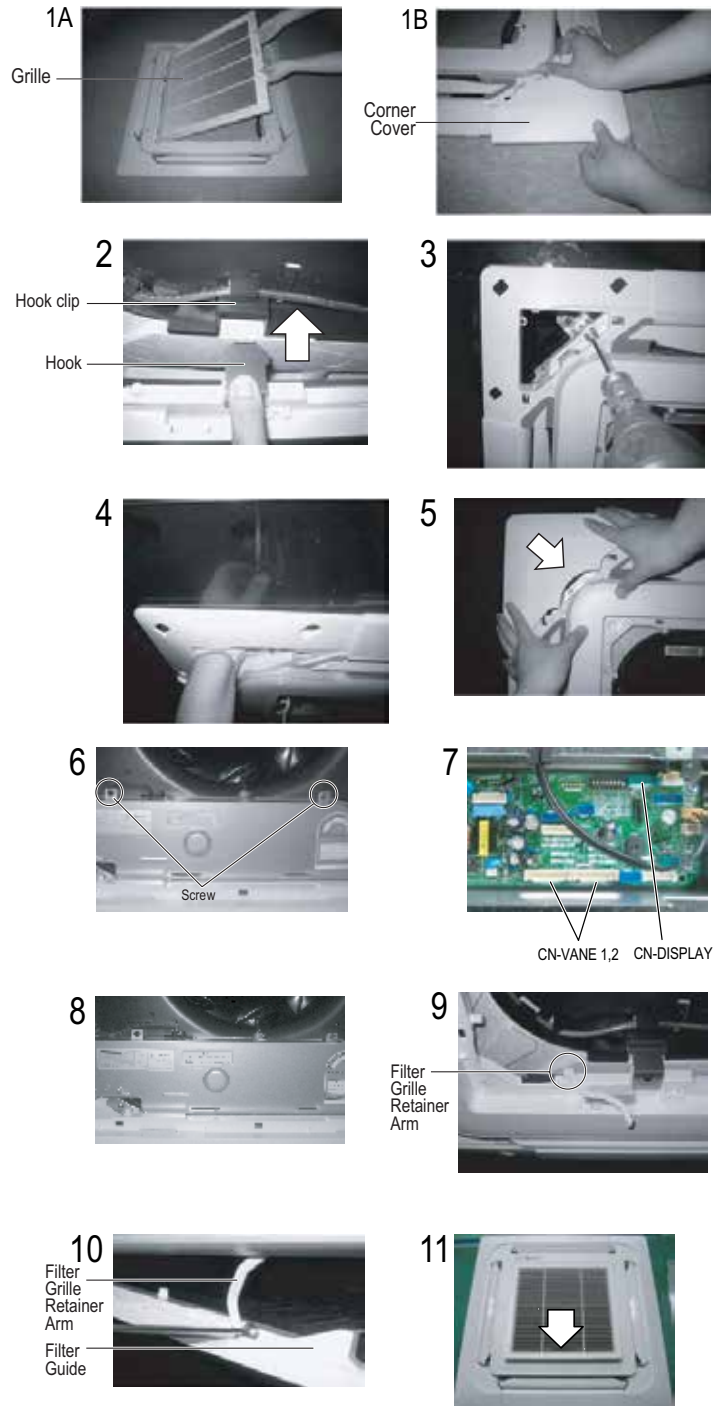
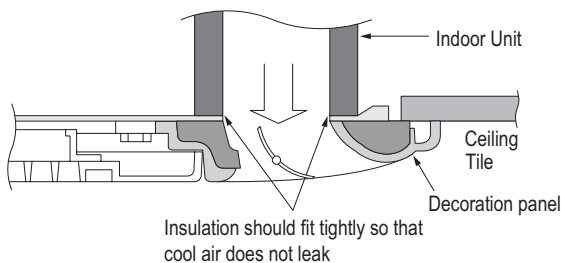

Figure 58: Ensure that no gaps are present between the indoor unit frame and the decoration grille.



### LG Monitoring View (LGMV) Diagnostic Software

LGMV software (PRCTSL1 and PRCTFE1) allows the service technician or commissioning agent to connect a computer USB port to the outdoor unit's main printed circuit board (PCB) using an accessory cable. The monitoring screen for LGMV allows the user to view the following real time data on one screen (Figure 59):

- Actual inverter compressor speed
- Target inverter compressor speed
- Actual outdoor fan speed
- Target outdoor unit fan speed
- Actual superheat
- Target superheat
- Actual subcooler circuit superheat
- Target subcooler circuit superheat
- Main EEV position
- Subcooling EEV position
- Inverter compressor current transducer value
- Outdoor air temperature
- Actual high pressure/saturation temperature
- Actual low pressure/saturation temperature
- Suction temperature
- Inverter compressor discharge temperature
- Front outdoor coil pipe temperature
- Back outdoor coil pipe temperature
- Liquid line pipe temperature
- Subcooler inlet temperature
- Subcooler outlet temperature
- Average indoor unit (IDU) pipe temperature
- Inverter compressor operation indicator light
- Liquid injection valves' operation indicator lights
- Hot gas bypass valve operation indicator light
- Four-way reversing valve operation indicator light
- Pressure graph showing actual low pressure and high pressure levels
- Error code display
- Operating mode indicator
- Target high pressure
- Target low pressure
- PCB (printed circuit board) version
- Software version
- Installer name
- Model number of IDUs

Figure 59: MV Real-time Data Screen.



- Site name
- Total number of connected IDUs
- Communication indicators
- IDU capacity
- IDU operating mode
- IDU fan speed
- IDU EEV position
- IDU room temperature
- IDU inlet pipe temperature
- IDU outlet pipe temperature
- IDU error code

#### Note:

Images on these pages are examples of LGMV screenshots. Actual images may differ depending on the version of the software and the unit installed.

Additional screens can be accessed by tabs on the main screen. Additional screens include the following:

1. Cycleview (Figure 60): Graphic of internal components including:
  - Compressors showing actual speeds
  - EEVs
  - IDUs
  - Temperature and pressure sensors
  - Four-way reversing valve
2. Graph: Full screen graph of actual high and low pressures and high and low pressure limits. A sliding bar enables user to go back in time and view data.
3. Control FTN: Enables user to turn on IDUs in 1.8°F increments.
4. Useful Tab
  - Unit Conversion: Converts metric values to imperial values.

Figure 60: MV Cycleview.

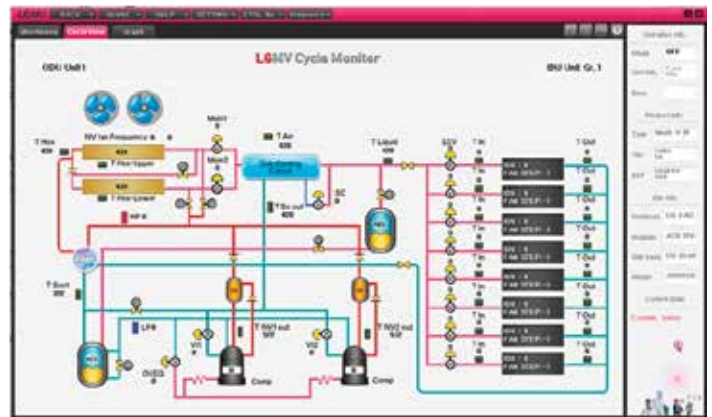

### LG Monitoring View (LGMV) Diagnostic Software and Cable - Continued

#### 5. Data

- Data Saving Start: Recording of real time data to a separate file created to be stored on the user's computer.
- Data Loading Start: Recorded data from a saved ".CSV" file can be loaded to create an LGMV session.

#### 6. Monitoring

- Electrical: The lower half of main screen is changed to show Inverter Compressor Amps, Volts, Power Hz, Inverter control board fan Hz.

#### Note:

Images on these pages are examples of LGMV screenshots. Actual images may differ depending on the version of the software and the unit installed.

### Error Codes

LGMV software helps the service technician or commissioning agent to troubleshoot system operation issues by displaying malfunction codes (Figure 62). These error codes can be seen on the main screen of the LGMV software program. For an overview of Multi F / Multi F MAX unit error codes, see Error Codes section. For detailed information on how to troubleshoot individual error codes, see the Multi F / Multi F MAX Service Manual.

The software is available in a high version with all of the listed features. The low version has all features as the high version without Target High Pressure and Target Low Pressure values shown on main screen.

In lieu of connecting to the outdoor unit, there is the option to connect to an IDU with the use of a USB to RS-485 connector kit. When connected through an IDU, the user will not be able to record data.

This software can be used to both commission new systems and troubleshoot existing systems. LGMV data can be recorded to a ".CSV" file and emailed to an LG representative to assist with diagnostic evaluations.

#### Recommended Minimum PC Configuration:

- CPU: Pentium® IV 1.6 GHz
- Main Memory: 1G
- Operating System: Windows® XP/Vista/7 32 bit (recommended), 64 bit
- Hard Disk: 600 MB when operating
- MS Office 2003, 2007 (recommended) for select reporting functions

Figure 61: MV Control Indoor Units Screen.



Figure 62: Error Code Screen.



# ELECTRICAL WIRING

## LG SIMS - Self Diagnosis Functions

# MULTI F

# MULTI F MAX

The SIMS WLAN module and the smart phone app together provide monitoring and troubleshooting capability for LG Duct Free Systems. SIMS functions only with LG Duct Free products (Figure 63).

SIMS can display and graph operational data for the air conditioner system including the indoor unit and the outdoor unit. SIMS also displays error codes and a troubleshooting guide. A full copy of the LG SIMS Smart Inverter Monitoring System User's Manual is available on the www.lghvac.com website.

To use SIMS you must be a trained HVAC service technician familiar with variable refrigerant flow (VRF) systems in general and with LG's Duct Free System products. You should understand the inverter air conditioning operation cycle, the meaning of the data displayed by SIMS, and how to use the data to troubleshoot the system.

Figure 64 shows a typical Multi F configuration used with the SIMS module and app.

Figure 63: LG SIMS App and WLAN Module



### ⚠ WARNING

High voltages capable of causing death are used in this equipment. Outdoor unit power remains connected during this procedure. Take extreme caution not to touch electrical components or connections. Failure to observe this warning can result in death or severe injury.

### Note:

- The Duct Free System air conditioning system must run for at least 15–20 minutes before data collected by SIMS 2.0 is valid for troubleshooting.
- You must have the free SIMS app correctly installed on your smart phone before using SIMS.
- Some ODU's have an LGMV extension cable accessed by removing the side handle cover. If the ODU does not have this extension cable, access the LGMV connector by removing the top cover of the ODU.

Figure 64: SIMS WLAN Module to a Typical Multi F System.



### SIMS App Main Info Screen

The main screen (Figure 65) is the first screen displayed after wireless connection is established. Tap the Main Info tab to display current readings regarding your indoor and outdoor unit(s). The Operational Info area of the screen will show active functions or modes by illuminating the light to the right of the function.

Additional Help information can be accessed by tapping the Help Menu buttons at the bottom of this screen.

Figure 65: SIMS App Main Info Screen

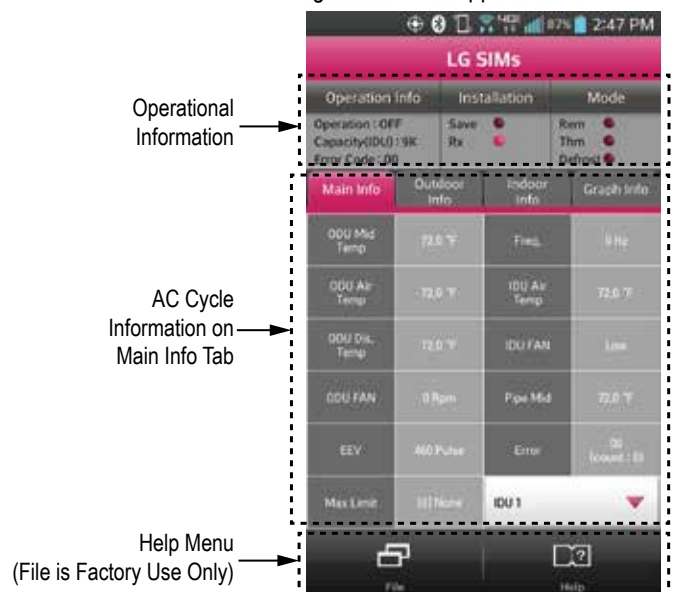

Multi F Ceiling Cassette Indoor Unit

### SIMS App Screens

#### Outdoor Info/ Component Screen

Displays the following information:

- Frequency
- FAN1 RPM
- FAN2 RPM
- DC Link
- Current
- Voltage
- EEV Mode
- Restart Timer
- Comp Mode
- EEV



#### Outdoor Info/ Temperature Screen

Displays the following information:

- Inv TD
- Suction
- Discharge
- Cond Mid
- Cond Out
- Heatsink
- Air Temp



#### Indoor Info Tab

Displays the following information:

- Frequency
- Operation
- THM Mode
- REM Mode
- FAN
- EEV
- Air Temp
- Pipe-in
- Pipe-mid
- Pipe-out



#### Graph Info Tab

This tab has three sub sections:

- IDU - Indoor Unit Temperature graph. Displays IDU information in graph format. Information displayed is for the IDU # selected on the Main screen.
- ODU - Outdoor Unit Temperature and Frequency graph. Displays ODU information in graph format.
- ODU Electric - Outdoor Unit Electric data graph is displayed.

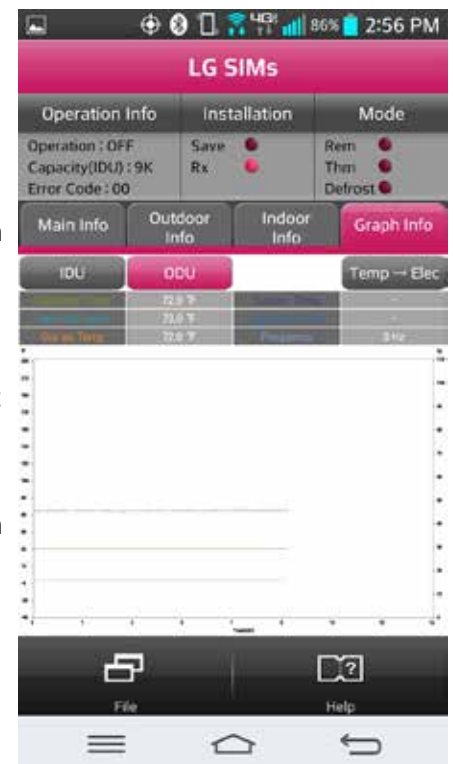

### Controller Options

Ceiling-concealed indoor units include a wireless handheld controller (AKB73757604)<sup>1</sup>, but optional LG-supplied wired controllers are available.

#### Wireless Handheld Controller

Figure 66: AKB73757604 Wireless Handheld Controller.

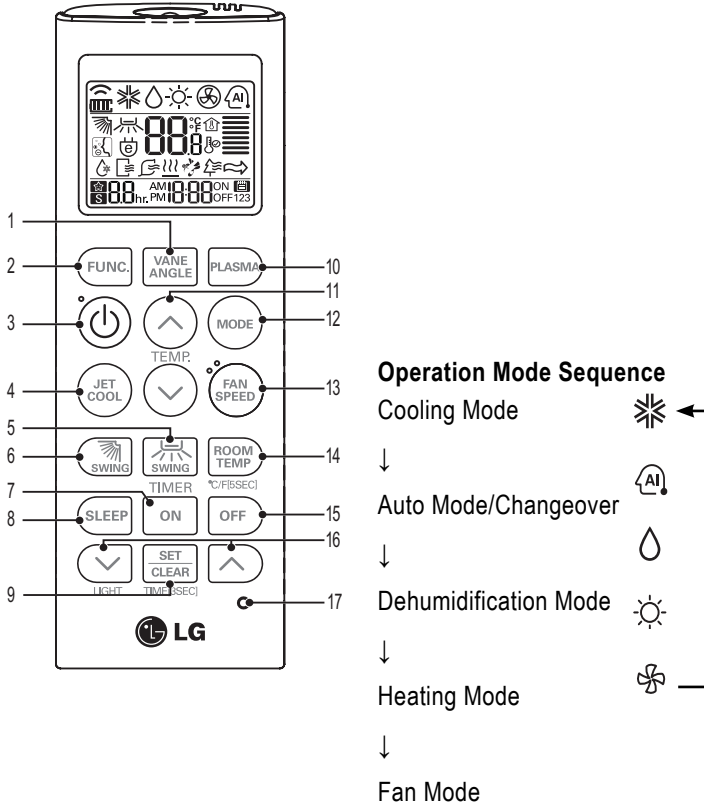
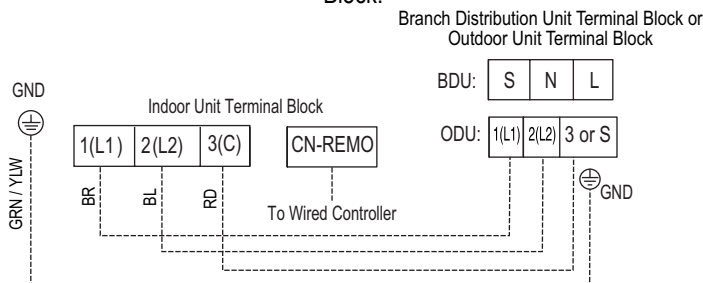

Table 35: AKB73757604<sup>1</sup> Wireless Handheld Controller Functions.<sup>2</sup>

Button Label	Description
1	Vane Angle Button: Sets the angle to each vane.
2	Function Setting Button: Sets or clears auto clean, smart clean, electric heater, or individual vane angle control functions.
3	On / Off Button: Turns the power on/off.
4	Jet Cool: Sets the unit to super high fan speed when in cooling mode.
5	Left / Right Air Flow Button (optional): Sets the desired left / right (horizontal) air flow direction.
6	Up / Down Air flow Button: Stops or starts louver movement, and sets the desired air flow direction to up or down.
7	On Time Button: Sets the time when the operation begins.
8	Sleep Timer Button: Sets the sleep mode operation.
9	Set / Clear Button: Sets or cancels the timer, also sets the current time.
10	Plasma Button: Starts or stops plasma-purification functions.
11	Room Temperature Setting Button: Raises or lowers temperature setpoint in cooling and heating operation.
12	Operation mode selection button: Selects the operation mode.
13	Indoor Fan Speed Button: Changes the fan speed to one of four choices: low, medium, high, and chaos.
14	Room Temperature Check Button: Displays / checks the room temperature.
15	Off Timer button: Sets the time when the operation ends.
16	Time Setting (Up / Down) / Light Button: Sets the timer and adjusts the brightness of the LED.
17	Reset Button: Resets the remote controller.

### Wired Controller Connections

Figure 67: Wired Controller Connection on the Indoor Unit Terminal Block.



<sup>1</sup>Wireless Handheld Controller for the four-way ceiling cassette indoor units is also referenced by Model No. PQWRHQ0FDB.

<sup>2</sup>Depending on the indoor unit model, some functions may not be supported or displayed.

### Wall-Mounted Controller Placement

Since the room temperature sensor is inside the remote controller, the remote controller should be installed in a place away from direct sunlight, high humidity and direct supply of hot or cold air to maintain proper space temperature. Install the remote controller about five (5) feet above the floor in an area with good air circulation and an average temperature.

⊘ Do not install the remote controller where it can be affected by the following:

- Drafts or dead spots behind doors and in corners
- Hot or cold air from ducts
- Radiant heat from the sun or appliances
- Concealed pipes and chimneys
- An area where temperatures are uncontrolled, such as an outside wall

This remote controller is equipped with a seven segment LED display. For proper display of the remote controller LEDs, the remote controller should be installed properly as shown below. The standard height is four (4) to five (5) feet from floor level.

1. Pull communications cable between the zone controller handy box (if used) and the indoor unit. The wall-mounted zone controller comes with a thirty-three (33) foot length of cable.
2. Store a minimal amount of cable in the handy box. Any additional cable should be coiled and stored near the indoor unit control panel.
3. If additional cable length is needed, order a thirty-three (33) foot LG Wired Remote Group Control Extension cable (Model No. PZCWRC1).
4. If the cable between the zone controller and the indoor unit is too long, do not cut the cable and shorten. Coil any spare communications cable, tie-wrap it, and leave it next to the indoor unit location.

Figure 68: Proper Location for the Wired Controller.

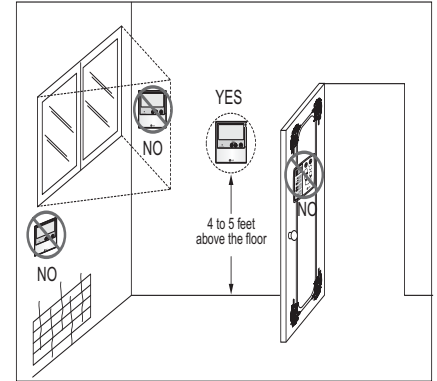

### Hanging the Wired Controller

1. The controller wiring / cable can be installed in one of three directions: top, back, or on the right side. If top or right side installation is desired, remove cable guide grooves on the controller, and then position wiring / cable on applicable side.
2. Choose and mark the area of installation, and then screw the wall plate into place (using the provided parts). Install the controller wall plate to fit the electrical box if one is present. Ensure that no gaps exist between the wall plate and the wall itself.
3. Arrange wiring / cables so it does not interfere with the controller circuitry. Position the wired controller on the wall plate. Snap into place by pressing the bottom part of the wired controller onto the wall plate. Make sure that no gaps exist between the wired controller and the wall plate on all sides.
4. To remove wired controller from the wall plate, insert a screwdriver into the two holes at the bottom. Twist screwdriver to release controller. ⊘ Do not damage the controller components when removing.

Figure 69: Removing the Cable Guide Grooves (Plate Appearance will Differ Depending on Controller Type).

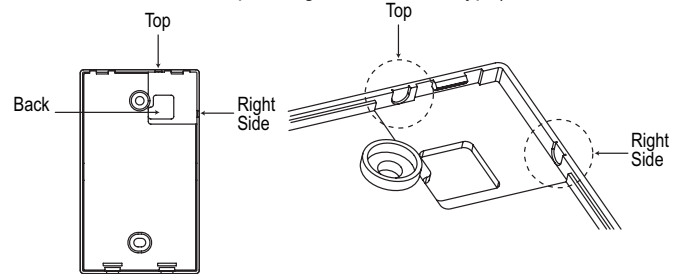

Figure 70: Attaching the Wall Plate (Plate Appearance will Differ Depending on Controller Type).

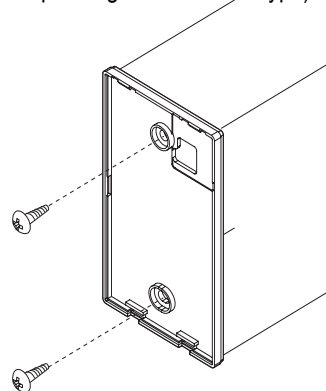
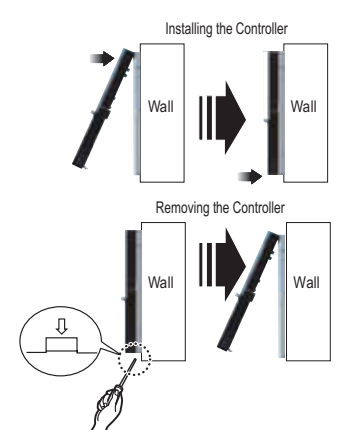

Figure 71: Installing / Removing the Controller.



### Hanging the Wired Controller, continued.

- Connect indoor unit and wired controller using included connection cable.
- Use an LG-manufactured extension cable (sold separately) if the distance between wired remote controller and the indoor unit is >32.8 feet.

Figure 72: Indoor Unit to Wired Controller Connection (Controller Appearance May Vary Depending on Model Chosen).

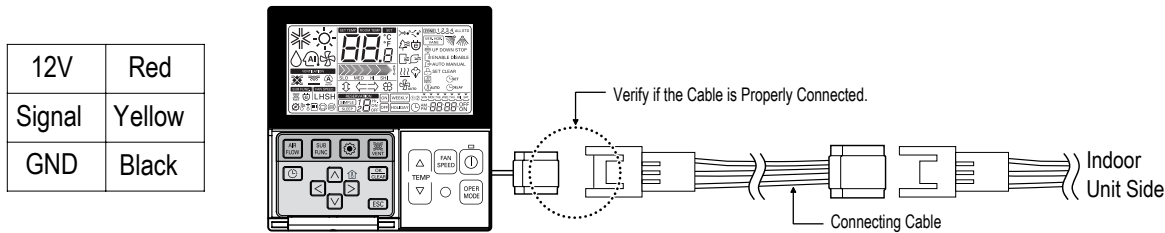

### Note:

- Do not bury the wired controller into the wall; burying it may damage the temperature sensor.
- Do not extend the connecting cable >164 feet; overly long cable lengths can cause communication errors.
- When installing the LG-manufactured extension cable, make sure to connect the proper ends together.

## Assigning the Thermistor for Temperature Detection

Each indoor unit includes a return air thermistor assigned to sense the temperature. If a wired controller is installed, there is a choice of sensing temperature with either the indoor unit return air thermistor or the thermistor in the wired controller. It is also an option to set both thermistors to sense temperature so that indoor unit bases its operation on the first thermistor to reach the designated temperature differential.

An optional Remote Temperature Sensor can be used in lieu of the return air thermistor—either alone or in conjunction with a wired controller thermistor as previously described.

### Troubleshooting Using Error Codes

Refer to Table 36 for information on the error codes that are generated from the indoor and outdoor units. These codes are the most common that will manifest through these units. Your particular model duct free system might generate additional codes not listed here. Please contact LG Support if you see these types of errors and a simple power down and boot up has not corrected the issue. You should not attempt to fix the system yourself.

#### Error Codes

- Error codes indicate different types of unit failures, assists in self-diagnosis and to track the frequency of occurrence.
- Error codes are shown on the LEDs of indoor units, wired remote controller, the outdoor unit control board, and LG Monitoring View (LGMV) Diagnostic Software.
- If two or more errors occur simultaneously, the lower error code number is displayed first.
- After error is resolved, the error code does not display.

#### Decoding the Error Display

The first and second number on the LED indicates error number.  
Example: 21 = LED1 2x blink, LED2 1x blink.

#### Error Code Nomenclature Definitions

- MICOM: Non-volatile memory chip where unit setup information is stored.
- EPROM: Non-volatile memory chip where device identification, size, and factory defined default component operating parameters are stored.

Figure 73: Example of Ceiling Cassette IDU LEDs (appearance may differ depending on model).

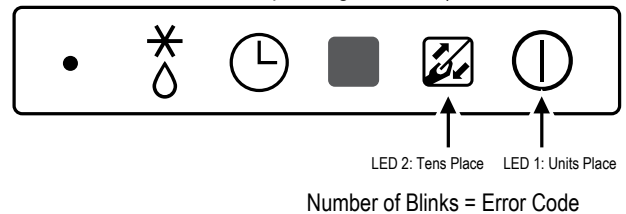

Table 36: Multi Zone Ceiling Cassette Indoor Unit Error Codes.

Error Code	Description	No. of Times Indoor Unit LEDs Blink	
		LED1 (Plasma LED)	LED2 (Power LED)
1	Indoor unit room temperature sensor error	1X	-
2	Indoor unit inlet pipe sensor error	2X	-
4	Float switch error (optional)	4X	-
5	Communication error between indoor unit and outdoor units	-	5X
6	Indoor unit outlet pipe sensor error	6X	-
9	Indoor unit EPROM error	9X	-
10	Indoor unit BLDC motor fan lock	-	1X
12	Indoor unit middle pipe sensor error	2X	1X

### Troubleshooting Using Error Codes - Continued

Table 37: Multi Zone Outdoor Unit Error Codes.

Error Code	Description	No. of Times Indoor Unit LEDs Blink	
		LED1 (Plasma LED)	LED2 (Power LED)
21	DC Peak (IPM Fault); Compressor DC voltage was too high	2X	1X
22	Current Transformer2 (CT2) error; Alternating current (AC) input too high	2X	2X
23	DC Link Low Volt	2X	3X
25	AC Low/High Volt	2X	5X
26	DC Comp Position Error (not providing rotation), Locking	2X	6X
27	PSC Fault; Current to inverter compressor between AC and DC converter circuit too high	2X	7X
28	Inverter compressor DC voltage is too high	2X	8X
29	Inverter compressor amperage is too high	2X	9X
31	Current-to-current transformer (CT) thermistor is too low	3X	1X
32	Inverter Compressor Discharge Pipe (D-Pipe) Overheat	3X	2X
40	CT Sensor Error; Thermistor is disconnected or shorted out	4X	-
41	D-Pipe Sensor INV is disconnected or shorted out	4X	1X
44	Outdoor Air Sensor is disconnected or shorted out	4X	4X
45	Middle thermistor of outdoor unit condenser coil is disconnected or shorted out	4X	5X
46	Outdoor unit suction line thermistor is disconnected or shorted out	4X	6X
48	Outdoor unit coil outlet (liquid line) thermistor is disconnected or shorted out	4X	8X
53	Communication failure from outdoor unit to indoor unit	5X	3X
60	Outdoor unit printed circuit board (PCB) EPROM check sum error	6X	-
61	Outdoor unit condenser coil temperature is too high	6X	1X
62	Outdoor unit inverter compressor PCB heat sink temperature is too high	6X	2X
63	Condenser coil pipe thermistor temperature is too low	6X	3X
65	Heat sink thermistor has disconnected or has shorted out	6X	5X
67	Outdoor brushless direct current (BLDC) fan motor lock error	6X	7X

Refer to Service Manuals posted on [www.lghvac.com](http://www.lghvac.com) for a full description of all error codes and workarounds.

## Cautions for Refrigerant Leaks

ASHRAE Standards 15 and 34 offer guidelines that address refrigerant safety and the maximum allowable concentration of refrigerant in an occupied space. Refrigerant will dissipate into the atmosphere, but a certain volume of air is required for this to occur safely. For R410A refrigerant, the maximum allowable concentration is 0.026 lbs./ft<sup>3</sup> per 1,000 ft<sup>3</sup> of air in an occupied space. Buildings with twenty-four (24) hour occupancy allow half of that concentration.<sup>1</sup>

ASHRAE Standards 15 and 34 assume that if a system develops a leak, its entire refrigerant charge will dump into the area where the leak occurs. To meet ASHRAE Standards 15 and 34, calculate the refrigerant concentration that may occur in the smallest room volume on the system, and compare the results to the maximum allowable concentration number (see below for information on how to calculate the refrigerant concentration).<sup>1</sup> Also consult state and local codes in regards to refrigerant safety.

### **⚠ WARNING**

Verify the maximum refrigerant concentration level in the space where the indoor unit will be mounted meets the concentration limit for the application. If the refrigerant leaks and safety limits are exceeded, it could result in personal injuries or death from oxygen depletion.

### **Note:**

Take appropriate actions at the end of HVAC equipment life to recover, recycle, reclaim or destroy R410A refrigerant according to applicable US EPA rules.

To calculate the potential refrigerant concentration level (RCL):

1. Measure the occupied space dimensions (in feet).
2. Calculate the cubic foot volume of air in the smallest occupied space. (To obtain a detailed overview of the RCL, perform the same calculations to the second smallest zone, the third smallest zone until the RCL is obtained for all zones. Also, pay special attention to areas such as basements, etc., where refrigerant cannot dissipate easily.)
3. Divide the refrigerant charge of the Multi Zone system serving the area in pounds by the results of step 1.
4. If the calculation indicates that the potential refrigerant concentration level is higher than the allowed RCL, increase the cubic volume of the smallest occupied space or modify the piping system design.
5. The allowable RCL limit for most applications must be equal to or less than 0.026 lbs./ft<sup>3</sup>. In special occupied spaces, however, such as hospitals and nursing homes where occupants may have limited mobility, the allowable RCL limit is cut in half. See ASHRAE Standard 34-2007 and local codes for detailed information.<sup>1</sup>

### Refrigerant Concentration Limit (RCL) Calculations

To calculate total refrigerant amount per system:

<b>Amount of Factory-Charged Refrigerant per Outdoor Unit</b>	<b>+</b>	<b>Amount of Additional Re- frigerant Trim Charge</b>	<b>=</b>	<b>Total System Refrigerant Charge</b>
---	----------	---	----------	--

$$\text{RCL (lbs./ft}^3\text{)} = \frac{\text{Total System Refrigerant Charge (lbs.)}}{\text{Volume of Smallest Occupied Space (ft}^3\text{)}}$$

<sup>1</sup>American Society of Heating, Refrigeration and Air Conditioning Engineers, Inc. (ASHRAE). Atlanta, GA. ASHRAE, Inc. Information about ASHRAE Standard 15-2010 / 34-2010 and addenda current as of the date of this publication.



## Major Component Rough-In

Description	Check
All Multi F / Multi F MAX outdoor units were connected properly per local code and the product installation procedures.	
All literature and bagged accessories have been removed from the fan discharge.	
Indoor units and branch distribution unit(s) (Multi F MAX only) are installed, properly supported, and located indoors in a non-corrosive environment.	
Multi F / Multi F MAX gravity condensate drain line was connected and routed where it properly drains away or, if installed in a mechanical room, was connected and properly routed to a drain terminal.	

## Piping and Insulation

Description	Check
Copper	
Over 5/8 inches—Rigid ACR only.	
5/8 inches and under—Can use soft ACR.	
15% silver brazing material only.	
All refrigerant pipes and valves were insulated separately. Insulation butts up against the walls of the indoor units. No gaps or cracks. Insulation was not compressed at clamps and hangers.	
LG Y-branches were used per manufacturer's recommendations.	
(Optional) Full port ball valves for all indoor units. (Schrader between the valve body and the indoor units.)	
Condensate piping installed on indoor units—material used is acceptable under local code. Insulated as necessary to prevent condensation.	

## Brazing Practices

Description	Check
Medical grade (there are 4 available) dry nitrogen for purging during brazing was used (constant 3 psi while brazing).	

## Installation

(For more information on any procedure, refer to the detail provided in the Indoor Unit Installation Manuals.)

## Refrigerant Piping

Description	Check
Have in possession a copy of the "As-Designed" LATS Multi F piping tree diagram. BEFORE ANY FIELD PIPE SIZE OR LENGTH CHANGES ARE MADE, PROPOSED CHANGES MUST BE FORWARDED TO THE DESIGN ENGINEER SO THAT THEY CAN INPUT THE CHANGES INTO LATS and RE-ISSUE A NEW LATS PIPING TREE DIAGRAM. Installer must receive change authorization from the design engineer, because any change made requires the review of the entire tree diagram and verification that the change did not impact the size of piping segments in other parts of the system.	
All pipe materials were properly stored, capped, and clean. All burrs were removed after cutting and pipe ends were reamed before brazing.	
During refrigerant pipe installation, for each segment of pipe, a record was made of the pipe length (including expansion loops, offsets, double-back sections), and sizes, as well as the quantity and type of elbows used.	
All long runs of straight pipe were provided with expansion loops.	
Ensure Y-branches are installed with no more than $\pm 5^\circ$ of horizontal.	
Ensure Y-branches are installed with no more than $\pm 3^\circ$ of vertical.	
A torque wrench and backup wrench were used to tighten all flare connections.	
The back side of all flares were lubricated with a small drop of PVE refrigeration oil before tightening flare fittings.	
Ensure all field made flares are $45^\circ$ . Use factory-supplied flare nuts only.	
Pipe segments were properly supported and all wall penetrations were sleeved.	
Pipe insulation was not compressed at any point.	
Y-branches were properly supported per details provided in the installation manual.	
Ensure Y-branches are installed in the correct direction. Flow is always from the single end to the double end.	
No oil traps, solenoid valves, sight glasses, filter driers, or any other unauthorized refrigerant specialties were present.	
(Optional) R410A rated full port ball valves were used at all indoor units and wherever appropriate in the refrigerant piping network.	
Best practice including a minimum of 20" of straight pipe was installed between each elbow.	



**Condensate Pump / Drain Installation**

Description	Check
Indoor unit condensate drain pipes were installed correctly.	
All condensate vertical risers are equal to or less than 27-1/2" from the bottom of the indoor unit.	
Indoor units with condensate pumps were level. Units with gravity drains were level or slightly canted toward the drain connection and are supported properly.	
Pumped condensate drain lines were properly connected (do not have traps, and connect to the top surface of the main drain line).	

**Power Wire and Communications Cables**

Description	Check
Power wiring was connected to a single phase 208-230V source.	
Ground wire was installed and properly terminated at the unit.	
The power supplied was clean with voltage fluctuations within specifications. ( $\pm 10\%$ of nameplate).	
Power wiring to the Multi F / Multi F MAX outdoor unit was installed per all local electrical code requirements.	
Power wiring to the indoor units and branch distribution unit(s) (Multi F MAX only) was installed per all local electrical code requirements.	
LG-supplied cable was used between each indoor unit and its zone controller. No cables were spliced and no wire caps are present.	
Communication type RS-485-BUS type.	
Communications / power were a minimum of 18-AWG, four (4) conductor, stranded, shielded or unshielded, with insulation material per local code. If shielded, must be ground to outdoor unit only. Cable segment shields were tied together.	
Used appropriate crimping tool to attach ring or spade terminals at all power wiring and control cable terminations.	
Power and control wires were run in the same conduit (ODU to IDU only) as provided in the product installation manual. Power to ODU and power/communications to IDU cannot be run in the same conduit and must be separated per manufacturer's guidelines.	



## Major Component Rough-In

## Piping and Insulation

## Brazing Practices



**Installation—Refrigerant Piping**

**Installation—Branch Distribution Unit (Multi F MAX Systems Only)**

**Installation—Condensate Pump / Drain Installation**

**Installation—Power Wire and Communications Cables**



LG Multi F outdoor units ship from the factory with a charge of R410A refrigerant. A trim charge may need to be added to take into account additional piping length.

To determine the additional refrigerant that is needed, apply the formula below, and record the results. If the total additional refrigerant charge value is a negative number, then an additional trim charge does not need to be added to the system.

### Multi F Outdoor Unit Factory Charge

Outdoor Unit	Factory Charge lbs. of R410A
LMU18CHV	3.96
LMU24CHV	3.96
LMU30CHV	6.18
LMU36CHV	6.18

### Multi F Outdoor Unit Additional Refrigerant Charge Formula

$$\begin{aligned} \text{Additional charge (lbs.)} &= (\text{Installed Length of Branch [A]} - \text{Chargeless Pipe Length [L]}) \times a \\ &+ (\text{Installed Length of Branch [B]} - \text{Chargeless Pipe Length [L]}) \times a \\ &+ (\text{Installed Length of Branch [C]} - \text{Chargeless Pipe Length [L]}) \times a \\ &+ (\text{Installed Length of Branch [D]} - \text{Chargeless Pipe Length [L]}) \times a \\ &- \text{CF (Correction Factor)} \times 5.29 \end{aligned}$$

**Note:**

- Number of installed length of branches depends on the specifications of the outdoor unit model.
- CF = Maximum number of connectable indoor units – Total number of connected indoor units.

### Multi F Outdoor Unit Piping Specifications

Multi F Outdoor Unit Model	Min. to Max. Piping Length for One Branch (ft.)	Max. Total System Piping Length (ft.)	Chargeless Pipe Length per Branch (L) (ft.)	Additional Charge Needed (a) (oz./ft.)
LMU18CHV	10 to 82	164	24.6	0.22
LMU24CHV	10 to 82	246.1	24.6	0.22
LMU30CHV	10 to 82	246.1	24.6	0.22
LMU36CHV	10 to 82	246.1	24.6	0.22

## Multi F Refrigerant Charge Calculations

$$\begin{aligned} &(\text{_____ [A]} - 24.6) \times 0.22 && (\text{_____}) \\ &+ (\text{_____ [B]} - 24.6) \times 0.22 && + (\text{_____}) \\ &+ (\text{_____ [C]} - 24.6) \times 0.22 && + (\text{_____}) \\ &+ (\text{_____ [D]} - 24.6) \times 0.22 && + (\text{_____}) \\ &- \text{_____ CF} \times 5.29 && - (\text{_____}) \\ &= \text{_____ Additional Charge (lbs.)} \end{aligned}$$

# MULTI F MULTI F MAX

# MULTI F MAX REFRIGERANT CHARGE WORKSHEET



LG Multi F MAX outdoor units ship from the factory with a charge of R410A refrigerant. A trim charge may need to be added to take into account additional piping length.

To determine the additional refrigerant that is needed, apply the formula below, and record the results. If the total additional refrigerant charge value is a negative number, then an additional trim charge does not need to be added to the system.

### Multi F MAX Outdoor Unit Factory Charge

Outdoor Unit	Factory Charge lbs. of R410A
LMU480HV	9.7
LMU540HV	9.7
LMU600HV	12.3

$$\begin{aligned} \text{Additional charge (lbs.)} &= (\text{Total Main Piping Length [A]} - \text{Chargeless Pipe Length of Main Pipe [L]}) \times a \\ &+ (\text{Installed Length of Branch [B1]} - \text{Chargeless Pipe Length [B]}) \times b \\ &+ (\text{Installed Length of Branch [B2]} - \text{Chargeless Pipe Length [B]}) \times b \\ &+ (\text{Installed Length of Branch [B3]} - \text{Chargeless Pipe Length [B]}) \times b \dots \\ &- \text{CF (Correction Factor)} \times 3.53 \end{aligned}$$

### Note:

- Number of installed length of branches depends on system specifications.
- CF = Maximum number of connectible indoor units – Total number of connected indoor units

### Multi F MAX Outdoor Unit Piping Specifications

Outdoor Unit Model	Main Piping Length		Branch Piping Length	
	Chargeless Pipe Length of Main Pipe (L) (ft.)	Additional Charge Needed (a) (oz./ft.)	Chargeless Pipe Length per Branch Pipe (B) (ft.)	Additional Charge Needed (b) (oz./ft.)
LMU480HV	16.4	0.54	16.4	0.22
LMU540HV	16.4	0.54	16.4	0.22
LMU600HV	16.4	0.54	16.4	0.22

### Multi F MAX Refrigerant Charge Calculations

$$\begin{aligned} &(\text{_____ [A]} - 16.4) \times 0.54 && (\text{_____}) \\ &+ (\text{_____ [B1]} - 16.4) \times 0.22 && + (\text{_____}) \\ &+ (\text{_____ [B2]} - 16.4) \times 0.22 && + (\text{_____}) \\ &+ (\text{_____ [B3]} - 16.4) \times 0.22 && + (\text{_____}) \\ &+ (\text{_____ [B4]} - 16.4) \times 0.22 && + (\text{_____}) \\ &+ (\text{_____ [B5]} - 16.4) \times 0.22 && + (\text{_____}) \\ &+ (\text{_____ [B6]} - 16.4) \times 0.22 && + (\text{_____}) \\ &+ (\text{_____ [B7]} - 16.4) \times 0.22 && + (\text{_____}) \\ &+ (\text{_____ [B8]} - 16.4) \times 0.22 && + (\text{_____}) \\ &- \text{_____ CF} \times 3.53 && - (\text{_____}) \\ &&& = \text{_____ Additional Charge (lbs.)} \end{aligned}$$

### **Who to call for assistance**

Freight Damage and Unit Replacements	Your LG Manufacturer Representative
Missing Parts	Your LG Manufacturer Representative
Freight Damage and Unit Replacements	Your LG Manufacturer Representative
Received Wrong Indoor Unit Model	Your LG Manufacturer Representative
Installation, Startup, and Commissioning Technical Assistance	1-888-865-3026

**For warranty information, visit [www.lghvac.com](http://www.lghvac.com).**

*Inverter*



LG Electronics, U.S.A., Inc.  
Commercial Air Conditioning Division  
4300 North Point Parkway  
Alpharetta, Georgia 30022  
[www.lg-vrf.com](http://www.lg-vrf.com)

LG Customer Information Center, Commercial Products  
1-888-865-3026 USA  
Follow the prompts for commercial A/C products and parts.

IM\_Multi\_F\_CeilingCassette\_7\_16  
Supersedes: M\_Multi\_F\_CeilingCassette\_9\_15



# MULTI F

# MULTI F MAX

## CEILING CASSETTE INDOOR UNIT INSTALLATION MANUAL



- LMCN077HV 7 kBtu
- LCN097HV4 9 kBtu
- LCN127HV4 12 kBtu
- LMCN185HV 18 kBtu

# PROPRIETARY DATA NOTICE

This document, as well as all reports, illustrations, data, information, and other materials are the property of LG Electronics U.S.A., Inc., and are disclosed by LG Electronics U.S.A., Inc., only in confidence.

*Do not throw away, destroy, or lose this manual.*

Please read carefully and store in a safe place for future reference.  
Content familiarity required for proper installation.

*The instructions included in this manual must be followed to prevent product malfunction, property damage, injury, or death to the user or other people. Incorrect operation due to ignoring any instructions will cause harm or damage. A summary of safety precautions begins on page 4.*

*For more technical materials such as submittals, engineering databooks, and catalogs, visit [www.lghvac.com](http://www.lghvac.com).*

IM\_Multi\_F\_CeilingCassette\_7\_16

For continual product development, LG Electronics U.S.A., Inc., reserves the right to change specifications without notice.

©LG Electronics U.S.A., Inc.

*This document, as well as all reports, illustrations, data, information, and other materials are the property of LG Electronics U.S.A., Inc.*

CONTENTS

Safety Instructions ..... 4

Introduction ..... 9

Unit Nomenclature ..... 11

General Data ..... 12

*Specifications* ..... 13

*Typical Multi F / Multi F Max Systems* ..... 15

*Refrigerant Piping Requirements* ..... 17

General Installation Guidelines..... 18

*Location Selection* ..... 18

*Inspection* ..... 19

*Install Ceiling Cassette* ..... 20

*Installing Drain System*..... 22

*Refrigerant Piping*..... 23

*Piping Materials and Handling*..... 31

Piping Connections..... 32

*Piping Preparation* ..... 32

*IDU to ODU* ..... 33

*Piping Insulation* ..... 36

Electrical Wiring..... 38

*General Guidelines*..... 38

*Power Wiring Specifications and Best Practices* ..... 39

*Controller Options*..... 40

*Power Wiring / Communications Cable Installation Guidelines* ..... 40

*Indoor Unit Electrical Connections Procedure*..... 41

*Decorative Grille Kit Installation*..... 43

*Self Diagnosis Functions* ..... 44

*LG SIMS - Self Diagnosis Functions* ..... 46

*Controller Options*..... 48

Troubleshooting ..... 51

*Error Codes* ..... 51

Cautions for Refrigerant leaks ..... 53

*Refrigerant Leaks* ..... 53

Installation Checklist..... 54

Pre-Commissioning Checklist..... 58

Commissioning Notes..... 62





Commissioning Checklist Exception Report..... 63

Multi F Refrigerant Charge Worksheet ..... 64

Multi F MAX Refrigerant Charge Worksheet ..... 65

The instructions below must be followed to prevent product malfunction, property damage, injury or death to the user or other people. Incorrect operation due to ignoring any instructions will cause harm or damage. The level of seriousness is classified by the symbols described below.

## TABLE OF SYMBOLS

 <b>DANGER</b>	<i>This symbol indicates an imminently hazardous situation which, if not avoided, will result in death or serious injury.</i>
 <b>WARNING</b>	<i>This symbol indicates a potentially hazardous situation which, if not avoided, could result in death or serious injury.</i>
 <b>CAUTION</b>	<i>This symbol indicates a potentially hazardous situation which, if not avoided, may result in minor or moderate injury.</i>
<b>Note</b>	<i>This symbol indicates situations that may result in equipment or property damage accidents only.</i>
	<i>This symbol indicates an action should not be completed.</i>

## Installation

### **DANGER**

 **Do not store or use flammable gas or combustibles near the unit.**

*There is risk of fire, explosion, and physical injury or death.*

 **Do not supply power to the unit until all wiring and piping are completed or reconnected and checked.**

*There is risk of physical injury or death due to electric shock.*

### **WARNING**

 **Do not install, remove, or re-install the unit by yourself (end-user). Ask the dealer or a trained technician to install the unit.**

*Improper installation by the user may result in water leakage, fire, explosion, electric shock, physical injury or death.*

**Always check for system refrigerant leaks after the unit has been installed or serviced.**

*Exposure to high concentration levels of refrigerant gas may lead to illness or death.*

 **Do not install the unit using defective hanging, attaching, or mounting hardware.**

*There is risk of physical injury or death.*

**For replacement of an installed unit, always contact an LG trained service provider.**

*There is risk of fire, electric shock, explosion, and physical injury or death.*



**Dispose of the packing materials safely.**

- *Packing materials, such as nails and other metal or wooden parts may cause puncture wounds or other injuries.*

- *Tear apart and throw away plastic packaging bags so that children may not play with them and risk suffocation and death.*

**The outdoor unit is shipped with refrigerant and the service valves closed.  Do not open service valves on the unit until all non-condensibles have been removed from the piping system and authorization has been obtained from the commissioning agent.**

*There is a risk of physical injury or death.*

 **Do not install the unit in any location exposed to open flame or extreme heat.  Do not touch the unit with wet hands.**

*There is risk of fire, electric shock, explosion, and physical injury or death.*

 **Do not run the compressor with the service valves closed.**

*There is risk of explosion, physical injury, or death.*

**Periodically check that the outdoor unit is not damaged.**

*There is risk of explosion, physical injury, or death.*

**Install the unit considering the potential for earthquakes.**

*Improper installation may cause the unit to fall, resulting in physical injury or death.*

**Replace all control box and panel covers.**

*If cover panels are not installed securely, dust, water and animals may enter the unit, causing fire, electric shock, and physical injury or death.*

 **Do not change the settings of the protection devices.**

*If the pressure switch, thermal switch, or other protection device shorted and forced to operate improperly, or parts other than those specified by LG are used, there is risk of fire, electric shock, explosion, and physical injury or death.*

**Wear protective gloves when handling equipment.**

*Sharp edges may cause personal injury.*

---

---

## Installation, continued

### ⚠ WARNING

If the air conditioner is installed in a small space, take measures to prevent the refrigerant concentration from exceeding safety limits in the event of a refrigerant leak.

Consult the latest edition of ASHRAE (American Society of Heating, Refrigerating, and Air Conditioning Engineers) Standard 15. If the refrigerant leaks and safety limits are exceeded, it could result in personal injuries or death from oxygen depletion.

**Properly insulate all cold surfaces to prevent “sweating.”**

*Cold surfaces such as uninsulated piping can generate condensate that could drip, causing a slippery surface that creates a risk of slipping, falling, and personal injury.*

---

### ⚠ CAUTION

**Be very careful when transporting the product.**

- Ⓞ Do not attempt to carry the product without assistance.
- Some products use polypropylene bands for packaging. Ⓞ Do not use polypropylene bands to lift the unit.
- Suspend the unit from the base at specified positions.
- Support the unit at a minimum of four points to avoid slippage from rigging apparatus.
- Failure to follow these directions may result in minor or moderate physical injury.

---

### Note:

LG Electronics U.S.A., Inc., is not responsible for any piping calculations, refrigerant leaks, degradation of performance, or any other potential problems or damages as a result of interconnecting piping, their joint connections, isolation valves, introduced debris inside the piping system, or other problems caused by the interconnecting piping system.

**Properly insulate all cold surfaces to prevent “sweating.”**

*Cold surfaces such as uninsulated pipe can generate condensate that may drip and cause water damage to walls.*

**When installing the unit in a hospital, mechanical room, or similar electromagnetic field (EMF) sensitive environment, provide sufficient protection against electrical noise.**

*Inverter equipment, power generators, high-frequency medical equipment, or radio communication equipment may cause the air conditioner to operate improperly. The unit may also affect such equipment by creating electrical noise that disturbs medical treatment or image broadcasting.*

Ⓞ **Do not use the product for special purposes such as preserving foods, works of art, wine coolers, or other precision air conditioning applications. This equipment is designed to provide comfort cooling and heating.**

*There is risk of property damage.*

Ⓞ **Do not make refrigerant substitutions. Use R410A only.**

*If a different refrigerant is used, or air mixes with original refrigerant, the unit will malfunction and be damaged.*

Ⓞ **Do not install the unit in a noise sensitive area.**

**When connecting refrigerant tubing, remember to allow for pipe expansion.**

*Improper piping may cause refrigerant leaks and system malfunction.*

**Periodically check that the unit is not damaged.**

*There is a risk of equipment damage.*

**Take appropriate actions at the end of HVAC equipment life to recover, recycle, reclaim or destroy R410A refrigerant according to applicable U.S. Environmental Protection Agency (EPA) rules.**

**Install the unit in a safe location where no one can step on or fall onto it. Ⓞ Do not install the unit with defective hanging, attaching, or mounting hardware.**

*There is risk of unit and property damage.*

**Install the drain hose to ensure adequate drainage.**

*There is a risk of water leakage and property damage.*

Ⓞ **Don't store or use flammable gas / combustibles near the unit.**

*There is risk of product failure.*

**Always check for system refrigerant leaks after the unit has been installed or serviced.**

*Low refrigerant levels may cause product failure.*

**The unit is shipped with refrigerant and the service valves closed. Ⓞ Do not open service valves on the unit until all non-condensibles have been removed from the piping system and authorization to do so has been obtained from the commissioning agent.**

*There is a risk of refrigerant contamination, refrigerant loss and equipment damage.*

## Wiring

### ⚠ DANGER

**High voltage electricity is required to operate this system. Adhere to the NEC code and these instructions when wiring. Improper connections and inadequate grounding can cause accidental injury or death.**

**Always ground the unit following local, state, and NEC codes.**  
*There is risk of fire, electric shock, and physical injury or death.*

**Turn the power off at the nearest disconnect before servicing the equipment.**  
*Electric shock can cause physical injury or death.*

**Properly size all circuit breakers or fuses.**  
*There is risk of fire, electric shock, explosion, physical injury or death.*

⊘ **Do not use damaged or loose power wiring.** ⊘ **Do not modify or extend the outdoor unit's power wiring randomly. Ensure that the power wiring will not be pulled nor weight be placed on the power wiring during operation.**  
*There is risk of fire, electric shock, and physical injury or death.*

### ⚠ WARNING

**The information contained in this manual is intended for use by an industry-qualified, experienced, trained electrician familiar with the U.S. National Electric Code (NEC) who is equipped with the proper tools and test instruments. Failure to carefully read and follow all instructions in this manual can result in equipment malfunction, property damage, personal injury or death.**

**All electric work must be performed by a licensed electrician and conform to local building codes or, in the absence of local codes, with the National Electrical Code, and the instructions given in this manual.**  
*If the power source capacity is inadequate or the electric work is not performed properly, it may result in fire, electric shock, physical injury or death.*

**Ensure the system is connected to a dedicated power source that provides adequate power.**  
*If the power source capacity is inadequate or the electric work is not performed properly, it may result in fire, electric shock, physical injury or death.*

**Refer to local, state, and federal codes, and use power wires of sufficient current capacity and rating.**  
*Wires that are too small may generate heat and cause a fire.*

**Secure all field wiring connections with appropriate wire strain relief.**  
*Improperly securing wires will create undue stress on equipment power lugs. Inadequate connections may generate heat, cause a fire and physical injury or death.*

**Properly tighten all power connections.**  
*Loose wiring may overheat at connection points, causing a fire, physical injury or death.*

⊘ **Do not change the settings of the protection devices.**  
*If the protection devices have been bypassed or are forced to operate improperly, or parts other than those specified by LG are used, there is risk of fire, electric shock, explosion, and physical injury or death.*

### Note:

⊘ **Do not cut, lengthen or shorten the communications and power cable between any dry contact unit and its connected indoor unit. Do not install the unit in a location where the communications and power cable cannot be safely and easily connected between the two units.** ⊘ **Do not allow strain on this cable.**  
*Poor cable connections can cause equipment malfunction.*

⊘ **Do not supply power to the unit until all electrical wiring, controls wiring, piping, installation, and refrigerant system evacuation are completed.**  
*System may malfunction.*

---

---

## Operation

### **⚠ DANGER**

- ⊘ Do not provide power to or operate the unit if it is flooded or submerged.

*There is risk of fire, electric shock, physical injury or death.*

### **Use a dedicated power source for this system.**

*There is risk of fire, electric shock, physical injury or death.*

- ⊘ Do not operate the disconnect switch with wet hands.

*There is risk of fire, electric shock, physical injury or death.*

### **Periodically verify the hanging bolts and other hardware securing the unit have not deteriorated.**

*If the unit falls from its installed location, it can cause physical injury or death.*

---

### **⚠ WARNING**

- ⊘ Do not allow water, dirt, or animals to enter the unit.

*There is risk of unit failure, fire, electric shock, physical injury or death.*

### **Avoid excessive cooling and periodically perform ventilation to the unit.**

*Inadequate ventilation is a health hazard.*

- ⊘ Do not touch the refrigerant piping during or after operation.

*It can cause burns or frostbite.*

- ⊘ Do not operate the unit with the panel(s) or protective cover(s) removed; keep fingers and clothing away from moving parts.

*The rotating, hot, cold, and high-voltage parts of the unit can cause physical injury or death.*

### **Periodically check power cable and connection for damage.**

*Cable must be replaced by the manufacturer, its service agent, or similar qualified persons in order to avoid physical injury and/or electric shock.*

**Use inert (nitrogen) gas when performing leak tests or air purges.** ⊘ Do not use compressed air, oxygen, or flammable gases.

*Using these substances may cause fire, explosion, and physical injury or death.*

### **If refrigerant gas leaks out, ventilate the area before operating the unit.**

*If the unit is mounted in an enclosed, low-lying, or poorly ventilated area and the system develops a refrigerant leak, it may cause fire, electric shock, explosion, physical injury or death.*

**Ensure no power is connected to the unit other than as directed in this manual. Remove power from the unit before removing or servicing the unit.**

*There is risk of unit failure, fire, electric shock, physical injury or death.*

- ⊘ Do not open the inlet grille of the unit during operation.
- ⊘ Do not operate the unit with the panels or guards removed.
- ⊘ Do not insert hands or other objects through the inlet or outlet when the unit is plugged in.
- ⊘ Do not touch the electrostatic filter, if the unit includes one.

*The unit contains sharp, rotating, hot, and high voltage parts that can cause personal injury and/or electric shock.*

### **Securely attach the electrical cover to the unit.**

*Non-secured electrical covers can result in burns or electric shock due to dust or water in the service panel.*

---

### **⚠ CAUTION**

**To avoid physical injury, use caution when cleaning or servicing the air conditioner.**

## Operation, continued

### Note:

Clean up the site after installation is finished, and check that no metal scraps, screws, or bits of wiring have been left inside or surrounding the unit.

⊘ Do not use this equipment in mission critical or special-purpose applications such as preserving foods, works of art, wine coolers or refrigeration. This equipment is designed to provide comfort cooling and heating.

Oil, steam, sulfuric smoke, etc., can significantly reduce the performance of the unit, or damage its parts.

⊘ Do not block the inlet or outlet.  
*Unit may malfunction.*

⊘ Do not open the inlet during operation.  
*There is risk of unit failure.*

**Provide power to outdoor unit to warm the compressor crankcase at least six (6) hours before operation begins.**

*Starting operation with a cold compressor sump(s) may result in severe bearing damage to the compressor(s). Keep the power switch on during the operational season.*

**Periodically verify the hanging bolts and other hardware securing the unit have not deteriorated.**

*If the unit falls from its installed location, it can cause property damage or product failure.*

⊘ Do not operate the unit with the panel(s) or protective cover(s) removed; keep fingers and clothing away from moving parts.

*Non-secured covers can result in malfunction due to dust or water in the service panel.*

⊘ Do not allow water, dirt, or animals to enter the unit.  
*There is risk of unit failure.*

**Use a only soft cloth to clean the air conditioner. ⊘ Do not use wax, thinner, or strong detergents.**

*Strong cleaning products may damage the surface of the air conditioner, or may cause its appearance to deteriorate.*

## Multi F and Multi F MAX Ceiling Cassette Units

This manual describes how to install the LG Multi F and Multi F MAX (Multi Zone) Ceiling Cassette Indoor Units (IDU) for Multi F heat pump systems. Table 1 lists the available models. Refer to LG's Multi F Indoor Unit Engineering Manual for complete detailed engineering data and selection procedures.

### Safety

Safety of personnel is the primary concern during all procedures. Read and understand the safety summary at the front of this manual. Read and understand this installation procedure before beginning installation. Use the appropriate tools and accessories during installation. Plan your work and do not work alone, if possible. Know how to obtain emergency medical and fire fighting assistance.

#### Installation Personnel

This equipment is intended for installation by personnel trained in the required construction, mechanical, electrical, and/or other disciplines.

#### Applicable Codes

Personnel must be familiar with and follow the applicable national, state, and / or local codes. In the event of a conflict between any applicable code and the instructions in this manual, comply with the applicable code.

### ⚠ WARNING

*Installation work must be performed by trained personnel and in accordance with national wiring standards and all local or other applicable codes. Improper installation can result in fire, electric shock, physical injury, or death.*

#### Note:

*Please read all instructions before installing this product. Become familiar with the unit, its components and connections, and the order of installation. Incorrect installation can degrade or prevent proper operation.*

### Factory Supplied Materials

- Installation Guide (template)
- Owner's Manual
- Installation Manual

### Required Tools (field provided)

- |                             |                     |                     |
|-----------------------------|---------------------|---------------------|
| • Level                     | • Flaring tool set  | • Hexagonal wrench  |
| • Screwdriver               | • Tubing cutter     | • Gas-leak detector |
| • Electrical lineman pliers | • Tube/pipe reamer  | • Gauge manifold    |
| • Electric drill            | • Torque wrenches   | • Thermometer       |
| • Hole core drill           | • Adjustable wrench |                     |

### Required Parts (field provided)

- |   |   |  |
|---|---|--|
| • Connecting cable (power and control)                | • 3/8" or 1/2" Threaded hanger rods                       | • Additional drain hose                |
| • Pipes - vapor line and liquid line, with insulation | • 3/8" or 1/2" nuts, flat washers, and lock/split washers | • Insulation for additional drain hose |

Figure 1: Typical Multi F Ceiling Cassette Indoor Unit



Table 1: Multi F Ceiling Cassette Indoor Units.





Typical Unit	Model Number	Nominal Capacity	
		Cooling (Btu)	Heating (Btu)
	LMCN077HV	7,000	8,100
	LCN097HV4	9,000	10,400
	LCN127HV4	12,000	13,800
	LMCN185HV	18,000	20,800

Table 2: Included Items.

Part	Quantity	Image	Part	Quantity	Image
Drain Hose	One (1)		Cable Ties	Four (4)	
Metal Clamp	Two (2)		Conduit Bracket	One (1)	
Insulation for Fittings	One (1) Set	 For Vapor Piping For Liquid Piping	M4 Screws	Two (2)	
Washers for Hanging Bracket	Eight (8)		Wireless Handheld Controller with Holder (AKB73757604) <sup>1</sup>	One (1)	

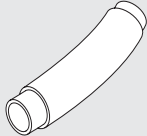
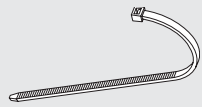
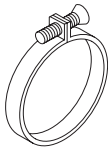
<sup>1</sup>Wireless Handheld Controller for the four-way ceiling cassette indoor units is also referenced by Model No. PQWRHQ0FDB.

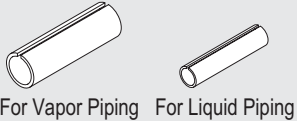
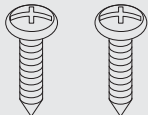
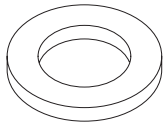
Table 3: Required Accessory Table.

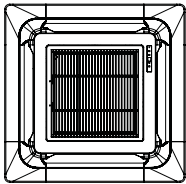
Part	Quantity	Image
Grille Kit (PT-QCHW0 or PT-UQC)	One (1)	

**Multi F Multi-Zone Systems — Indoor Units**

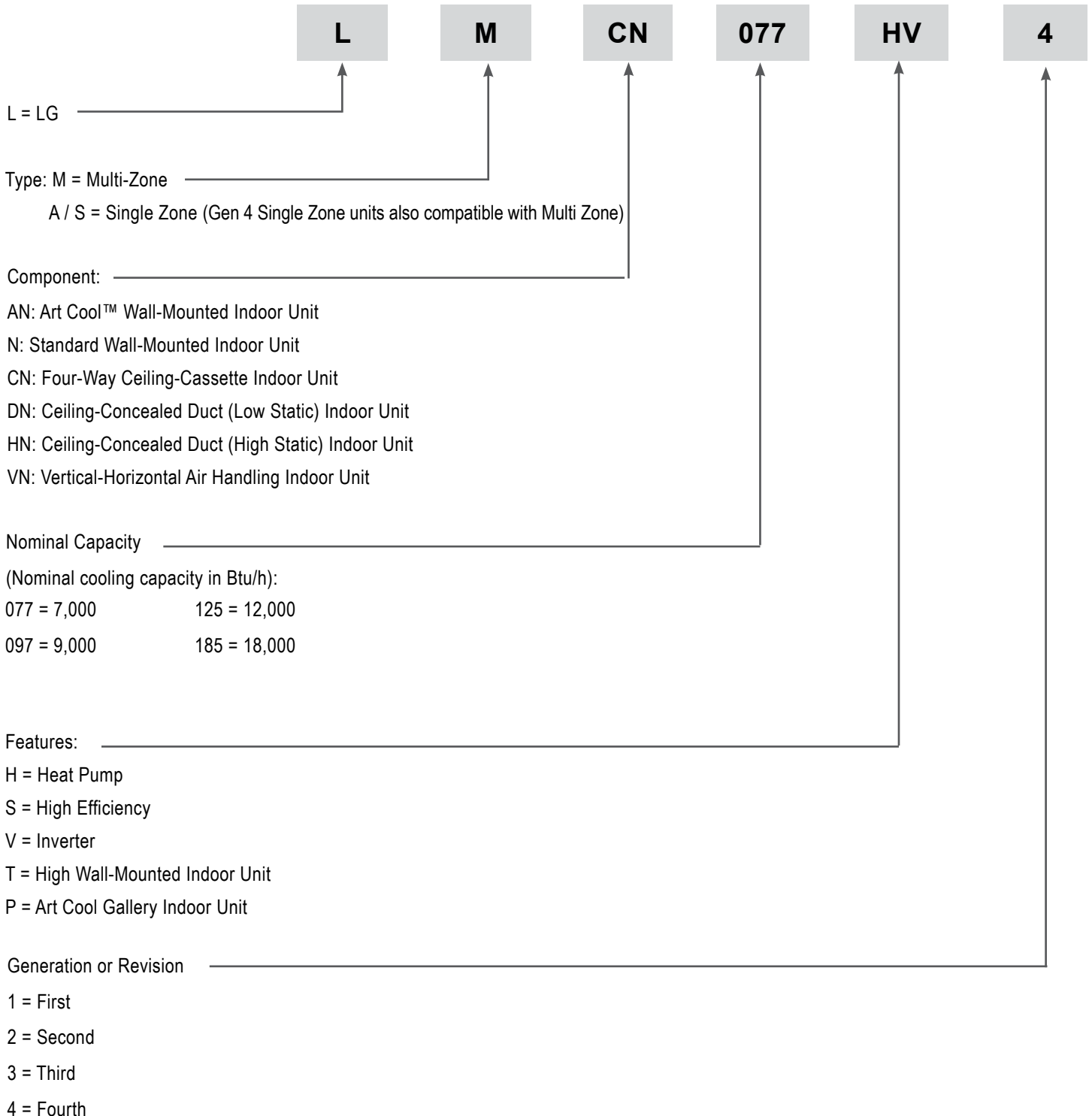

- Voltage for all equipment is 208-230V, 60 Hz, 1-phase.
- All indoor units are compatible with wired controllers



## R410A Refrigerant

R410A refrigerant has a higher operating pressure in comparison to R22 refrigerant and, therefore, all piping system materials installed must have a higher resisting pressure than the materials traditionally used in R22 systems.

R410A refrigerant is an azeotrope of R32 and R125, mixed at 50:50, so the ozone depletion potential (ODP) is 0.

### ⚠ WARNING

⊘ Do not place refrigerant cylinder in direct sunlight. Refrigerant cylinder may explode causing severe injury or death.

### Note

- Because R410A is a combination of R32 and R125, the required additional refrigerant must be charged in its liquid state. If the refrigerant is charged in its gaseous state, its composition changes and the system will not work properly.
- ⊘ Do not heat piping more than necessary during installation. Piping may become soft and fail when pressurized.
- ⊘ Do not use any piping that has not been approved for use in high-pressure refrigerant systems. Piping wall thickness must comply with the applicable local, state, and federal codes for the 551 psi design pressure of R410A. Inadequate piping may fail when pressurized.

## Allowable Indoor Unit to Outdoor Unit Connections

In Multi F / Multi F MAX multi-zone systems, the Ceiling Cassette IDUs can be connected to the Multi F outdoor units (ODUs) listed in the table below.

Table 4: Allowable Indoor Unit to Outdoor Unit Connections.

Indoor units		Outdoor units						
Model Number	Indoor Unit Nominal Capacity (Btu/h)	LMU18CHV	LMU24CHV	LMU30CHV	LMU36CHV	LMU480HV	LMU540HV	LMU600HV
		Maximum No. of Connectable Indoor Units						
		2	3	4	4	8	8	8
LMCN077HV	7,000	0	0	0	0	0	0	0
LCN097HV4	9,000	0	0	0	0	0	0	0
LCN127HV4	12,000	0	0	0	0	0	0	0
LMCN185HV	18,000	-	0	0	0	0	0	0

connection allowed: 0

connection not allowed: -

## Device Connection Limitations

- The minimum number of connected and operating indoor units to Multi F / Multi F MAX systems is two.
- The maximum number of indoor units for each Multi F / Multi F MAX heat pump system is:

LMU18CHV = 2    LMU24CHV = 3    LMU30CHV = 4    LMU36CHV = 4    LMU480HV = 8    LMU540HV = 8    LMU600HV = 8

- The maximum allowable total indoor unit capacity (Btu/h) for each Multi F / Multi F MAX heat pump system is:  
 LMU18CHV = 24,000    LMU30CHV = 40,000    LMU480HV = 65,000    LMU600HV = 81,000  
 LMU24CHV = 33,000    LMU36CHV = 48,000    LMU540HV = 73,000

- Refer to the Multi F Engineering Manual to properly determine total indoor unit connected capacity.

Table 5: Multi F Multi Zone Ceiling Cassette Indoor Unit Specifications.

Model Name	LMCN077HV	LCN097HV4	LCN127HV4	LMCN185HV
Grille (Sold Separately)	PT-QCHW0 / PT-UQC	PT-QCHW0 / PT-UQC	PT-QCHW0 / PT-UQC	PT-QCHW0 / PT-UQC
Nominal Cooling Capacity (Btu/h) <sup>1</sup>	7,000	9,000	12,000	18,000
Nominal Heating Capacity (Btu/h) <sup>1</sup>	8,100	10,400	13,800	20,800
<b>Operating Range</b>				
Cooling (°F WB)	57-77			
Heating (°F DB)	59-81			
<b>Fan</b>				
Type	Turbo			
Motor Output (W) x Qty.	43 x 1			
Motor/Drive	Brushless Digitally Controlled / Direct			
Airflow Rate CFM (H/M/L)	265 / 212 / 177	300 / 265 / 230	335 / 283 / 247	459 / 424 / 388
<b>Unit Data</b>				
Refrigerant Type <sup>2</sup>	R410A			
Refrigerant Control	EEV			
Power Supply V, Ø, Hz <sup>3</sup>	208-230, 1, 60			
Rated Amps (A)	0.25			
Sound Pressure Level ±3 dB(A) (H/M/L) <sup>4</sup>	31 / 27 / 24	36 / 33 / 30	38 / 35 / 32	38 / 37 / 34
Body Dimensions (W x H x D, in.)	22-7/16 x 8-7/16 x 22-7/16			22-7/16 x 10-3/32 x 22-7/16
Grille (PT-UQC, sold separately) Dimensions (WxHxD, in.)	27-9/16 x 7/8 x 27-9/16			
Body Net Weight (lbs.)	31			34
Grille (Sold separately) Net Weight (lbs.)	7			
Body Shipping Weight (lbs.)	34	37		42
Grille (Sold separately) Shipping Weight (lbs.)	11	9	9	11
Power Wiring / Communications Cable (No. x AWG) <sup>5</sup>	4 x 18			
Heat Exchanger (Row x Column x Fin / inch) x No.	(2 x 8 x 18) x 1			(2 x 10 x 18) x 1
<b>Pipe Size</b>				
Liquid (in.)	1/4			
Vapor (in.)	3/8			1/2
Drain O.D. / I.D. (in.)	1-1/4, 1			

<sup>1</sup>Nominal capacity is rated 0 ft. above sea level with corresponding refrigerant piping length in accordance with standard length of each outdoor unit and a 0 ft. level difference between outdoor and indoor units. All capacities are net with a combination ratio between 95 – 105%.

Nominal cooling capacity rating obtained with air entering the indoor unit at 80°F dry bulb (DB) and 67°F wet bulb (WB) and outdoor ambient conditions of 95°F dry bulb (DB) and 75°F wet bulb (WB).

Nominal heating capacity rating obtained with air entering the indoor unit at 70°F dry bulb (DB) and 60°F wet bulb (WB) and outdoor ambient conditions of 47°F dry bulb (DB) and 43°F wet bulb (WB).

<sup>2</sup>This unit comes with a dry helium charge.

<sup>3</sup>Acceptable operating voltage: 187V-253V.

<sup>4</sup>Sound pressure levels are tested in an anechoic chamber under ISO Standard 3745 and are the same in both cooling and heating mode. These values can increase due to ambient conditions during operation.

<sup>5</sup>All power wiring / communications cable to the IDUs be minimum 18 AWG, 4-conductor, stranded, shielded or unshielded (if shielded, must be grounded to chassis at ODU only) and must comply with applicable local and national codes.

Figure 2: Multi F Four-Way Ceiling-Cassette Indoor Unit Refrigerant Flow Diagram.

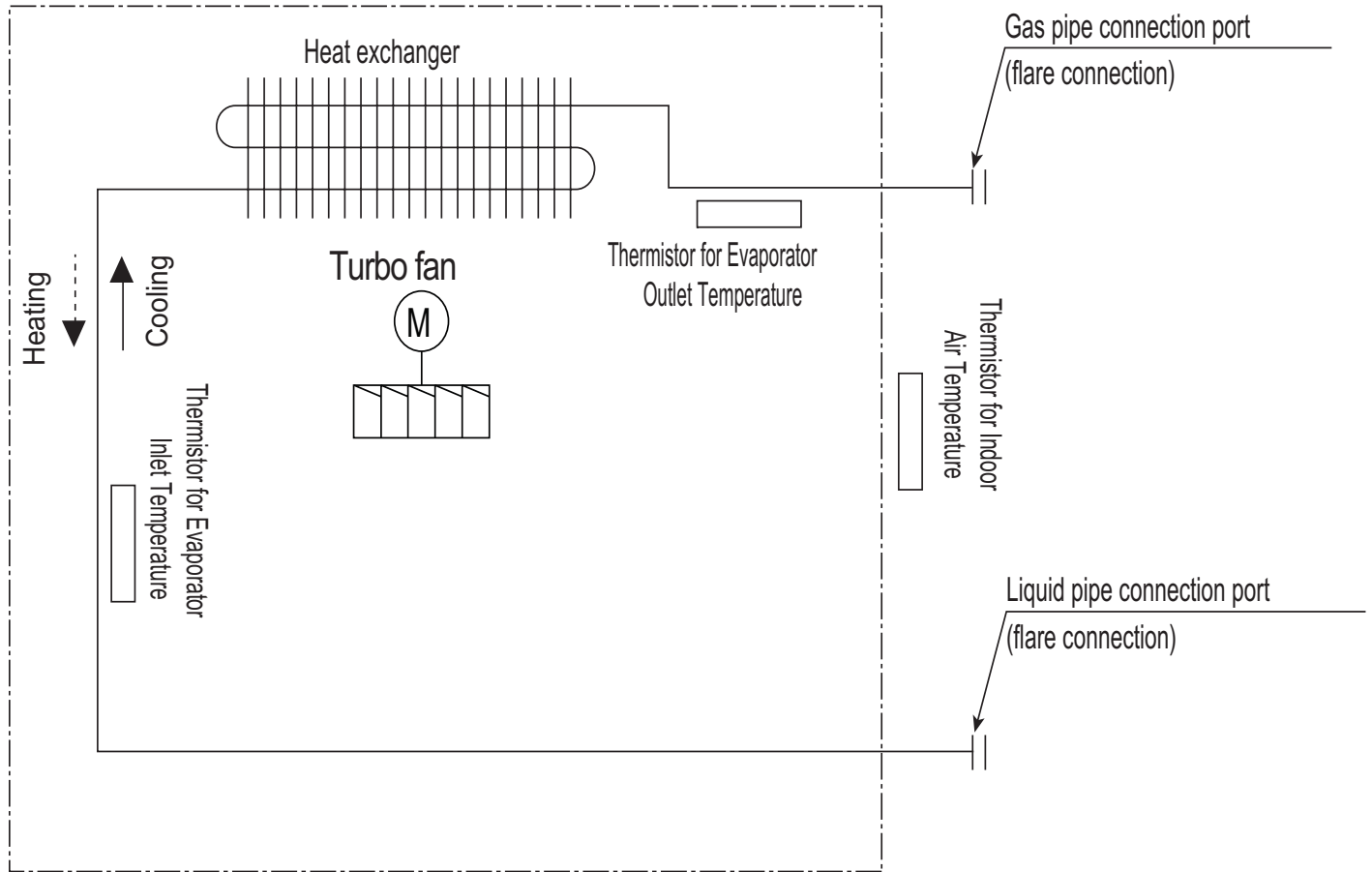

Table 6: Multi F Multi Zone Art Cool Mirror Wall-Mounted Indoor Unit Refrigerant Pipe Connection Port Diameters.

Model No.	Vapor (inch)	Liquid (inch)
LMCN077HV	Ø3/8	Ø1/4
LCN097HV4		
LCN127HV4		
LMCN185HV	Ø1/2	

### Major System Components

A typical Multi F system consists of an outdoor unit (ODU), refrigerant piping, and two (2) to four (4) indoor units (IDUs). The ceiling cassette units described in this manual are one of the types of IDUs that can be connected to a Multi F system.

A typical Multi F Max system consists of an ODU, refrigerant piping, one or two branch distribution units (BDU), and two (2) to eight (8) IDUs. The ceiling cassette units described in this manual are one of the types of IDUs that can be connected to a Multi F Max system.

### Typical Multi F System

Example: LMU36CHV outdoor unit with four (4) indoor units connected.

ODU: Outdoor Unit.

IDU: Indoor Unit.

A, B, C, D: Piping from Outdoor Unit to Indoor Unit.

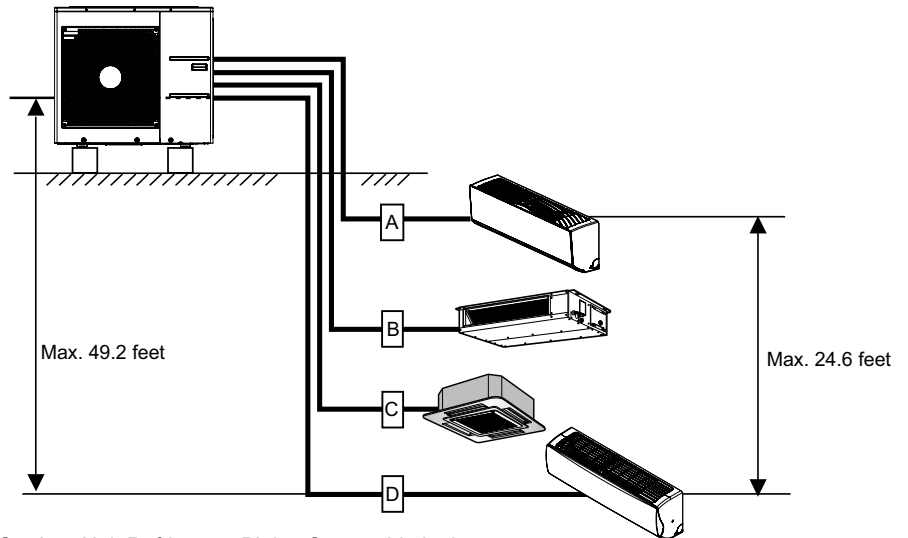

Table 7: Multi F Outdoor Unit Refrigerant Piping System Limitations.

Outdoor Unit	Minimum Length for Each Pipe Segment (ft.)	Maximum Equivalent Pipe Length to Each Indoor Unit (ft.)				Maximum Equivalent Pipe Length for Each System (ft.)
		A	B	C	D	
LMU18CHV	9.8	82	82	-	-	164
LMU24CHV	9.8	82	82	82	-	246.1
LMU30CHV	9.8	82	82	82	82	246.1
LMU36CHV	9.8	82	82	82	82	246.1

### Typical Multi F MAX System with One Branch Distribution Unit

Example: LMU540HV outdoor unit with four (4) indoor units, and one (1) branch distribution unit connected.

ODU: Outdoor Unit.

IDU: Indoor Unit.

BDU: Branch Distribution Unit.

A: Main Piping.

B: Branch Piping (Branch Distribution Unit to Indoor Unit[s]).

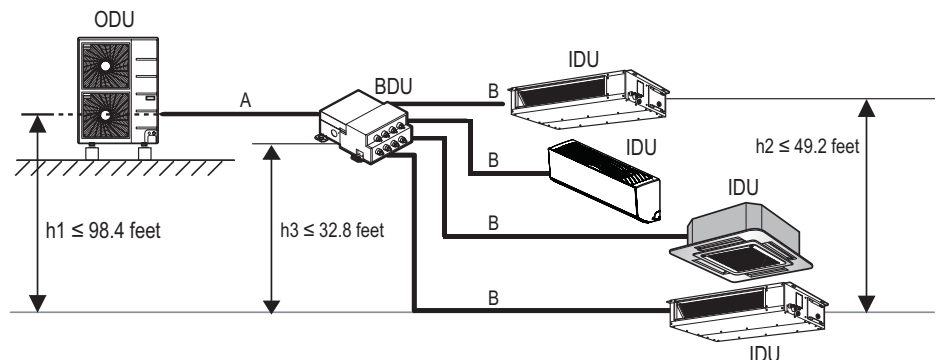

# GENERAL DATA

Typical Multi F/Multi F Max Systems

**MULTI F**  
**MULTI F MAX**

## Typical Multi F MAX System with Two Branch Distribution Units

Example: LMU540HV outdoor unit with seven (7) indoor units, and two (2) branch distribution units connected.

ODU: Outdoor Unit.

IDU: Indoor Unit.

BD: Branch Distribution Unit(s).

$\Sigma A$ : Main Piping.

$\Sigma B$ : Branch Piping (Branch Distribution Unit[s] to Indoor Unit[s]).

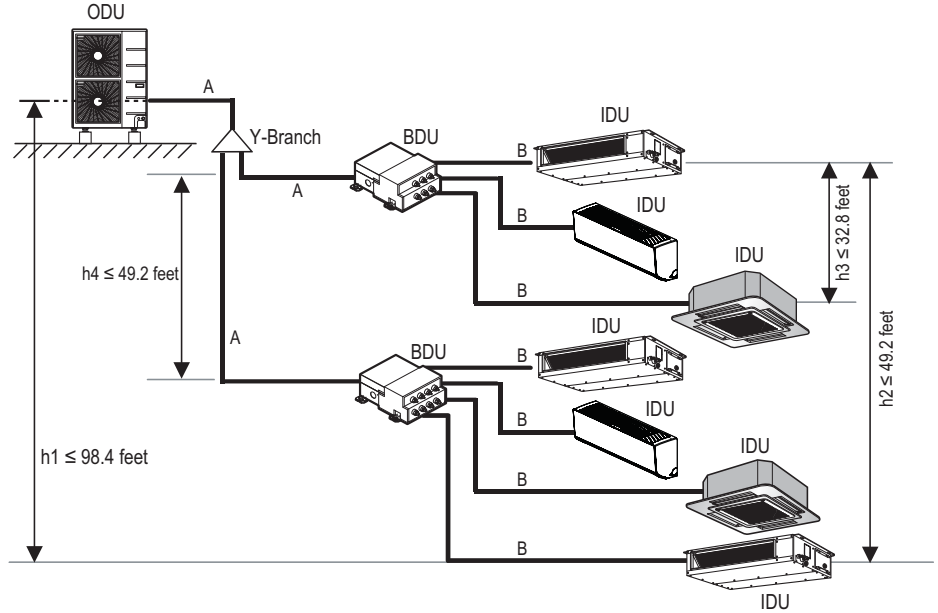

Table 8: Multi F MAX LMU480HV, LMU540HV, and LMU600HV Outdoor Unit Refrigerant Piping System Limitations.

Pipe Length (ELF = Equivalent Length of pipe in Feet)	Total piping length ( $\Sigma A + \Sigma B$ )		≤475.7 feet
	Main pipe (Outdoor Unit to Branch Distribution Units: $\Sigma A$ )	Minimum	9.8 feet
		Maximum	≤180.4 feet
	Total branch piping length ( $\Sigma B$ )		≤295.3 feet
	Branch pipe (Branch Distribution Units to Indoor Units: B)	Minimum	9.8 feet
Maximum		≤49.2 feet	

Elevation Differential (All Elevation Limitations are Measured in Actual Feet)	If outdoor unit is above or below indoor unit (h1)		≤98.4 feet
	Between the farthest two indoor units (h2)		≤42.9 feet
	Between branch distribution unit and farthest connected indoor unit(s) (h3)		≤32.8 feet
	Between branch distribution units (h4)		≤42.9 feet

Table 9: Multi F MAX Piping Sizes.

Piping	Main Pipe A (inch)	Branch Pipe B
Liquid	Ø3/8	Depends on the size of the indoor unit piping
Gas	Ø3/4	

Multi F Ceiling Cassette Indoor Unit

### Field Supplied Refrigerant Piping

Type ACR copper is the only approved refrigerant pipe material for use with LG Multi F air conditioning products. ACR rated tubing is the only type that ships with yellow caps. Approved tubing for use with Multi F products will be marked “R410 RATED” along the length of the tube. Tube wall thickness should meet local code requirements and be approved for a maximum operating pressure of 551 psi.

Refer to the refrigerant piping section (starting on page 23) of the General Installation Guidelines for more information on piping.

### Using Refrigerant Components

Field-supplied elbows are allowed if they are long radius and designed for use with R410A refrigerant. Be sure to account for the additional pressure losses in equivalent pipe length calculations for each elbow, Y-branch, and branch distribution unit. The equivalent pipe length of each elbow, Y-branch, and/or branch distribution unit must be added to each pipe segment to ensure maximum lengths are not exceeded.

Table 10: Equivalent Piping Length for Elbows, Y-branches, and Branch Distribution Units.

Component	Size (Inches)				
	1/4	3/8	1/2	5/8	3/4
Elbow (ft.)	0.5	0.6	0.7	0.8	1.2
Y-Branch Kit (ft.) (Multi F MAX systems only) <sup>1</sup>	1.6				
Branch Distribution Unit (ft.) (Multi F MAX systems only)	8.2				

<sup>1</sup>Kit contains two Y-branches: one for liquid and one for vapor.

## Location Selection

### **⚠ DANGER**

⊘ To avoid the possibility of fire, do not install the unit in an area where combustible gas may generate, flow, stagnate, or leak. Installing the unit in an area containing combustible gas will cause serious bodily injury or death.

#### **Note:**

Before beginning installation, read the safety summary at the beginning of this manual.

Select a location for installing the ceiling cassette indoor unit (IDU) that meets the following conditions:

- Place the unit where air circulation will not be blocked.
- Place the unit where drainage can be obtained easily.
- Place the unit where noise prevention is taken into consideration.
- Ensure there is sufficient strength to bear the load of the indoor unit.
- Ensure there is sufficient maintenance space.
- Locate the indoor unit in a location that is level, and where it can be easily connected to the outdoor unit / branch distribution unit.

### **⚠ WARNING**

The unit may be damaged, may malfunction, and / or will not operate as designed if installed in any of the conditions listed.

- ⊘ The unit should not be installed near a heat or steam source, or where considerable amounts of oil, iron powder, or flour are used.
- ⊘ Do not install the unit in an area where combustible gas may generate, flow, vent into, stagnate, leak, or be stored.
- ⊘ Do not install the unit in a location where acidic solution and spray (sulfur) are often used.
- ⊘ Do not use the unit in environments where oil, steam, or sulfuric gas are present.
- ⊘ Avoid installing the unit near high-frequency generators or near any equipment that generates an electromagnetic field (minimum 3-1/3 feet away)
- ⊘ Do not install the unit near a doorway.

#### **Note:**

If the unit is installed near a body of water, certain components are at risk of being corroded. Appropriate anti-corrosion methods should be taken for the unit and all components.

#### **Installing in a High or Dropped Ceiling**

High or dropped ceilings, often found in commercial buildings and offices, may cause a wide temperature differentiation. To countermeasure:

- Change the indoor unit mode selection to allow for higher ceilings (see table).
- Install an air circulator.
- Set the air discharge outlet so that heated air flows in a downward direction.
- Use a dual door system to protect the building gate or exit.

Table 11: Ceiling Cassette Indoor Unit High Ceiling Mode Selection Options.

Ceiling Height	Mode Selection
≤7-1/2 feet	Low Ceiling
7-1/2 feet to 8-7/8 feet	Standard
8-7/8 feet to 10-3/16 feet	High Ceiling
10-3/16 feet to 11-13/16 feet	Very High Ceiling

#### **Installing in an Area Exposed to Unconditioned Air**

In some installation applications, areas (floors, walls) in some rooms may be exposed to unconditioned air (room may be above or next to an unheated garage or storeroom). To countermeasure:

- Verify that carpet is or will be installed (carpet may increase the temperature by three (3) degrees).
- Add insulation between the floor joists.
- Install radiant heat or another type of heating system to the floor.

**Installing in an Area with High Humidity Levels**

If the environment is prone to humidity levels of 80% or more (near the ocean, lakes, etc.) or where steam could collect in the plenum:

- Install additional insulation to the indoor unit (glass wool insulation >13/32 inches thick).
- Install additional insulation to the refrigerant piping (insulation >13/16 inches thick).
- Seal all gaps between the indoor unit and the ceiling tiles (make the area air tight) so that humidity does not transfer from the plenum to the conditioned space. Also, add a ceiling grille for ventilation.

Figure 3: Installing in a Highly Humid Location.

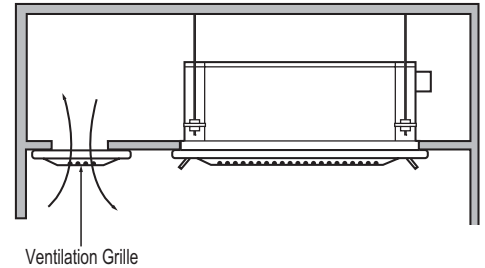

**Installing Multiple Indoor Units in One Area**

Ensure there is enough space between indoor units, lighting fixtures, and ventilation fans / systems.

Figure 4: Installing Multiple Indoor Units.

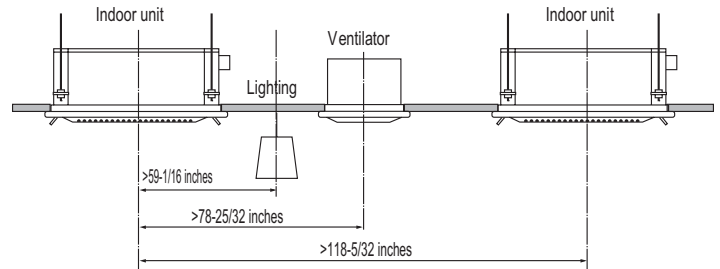

**Required Clearances**

Figure 5 shows required clearance distances around a typical installed unit.

Figure 5: Required Clearances Around Typical Installed Unit.

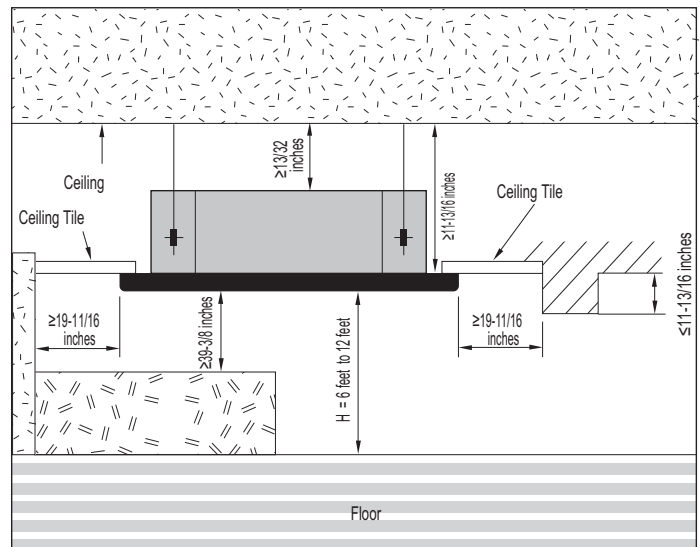

**Unpack and Inspect for Freight Damage**

**CAUTION**

Shipping and net weights of the ceiling cassette units are listed in Table 5. To help avoid injury to personnel, use two people when carrying a unit by hand.

**Note:**

- Do not unpack the unit and remove the protective materials until ready to install. Before unpacking, carefully move the packaged unit to a work area near the installation location.
- To help avoid damage to the unit, use two people when carrying a unit by hand.

After opening, if the unit is damaged, repack the unit as it was shipped. **RETAIN ALL PACKING MATERIALS.** In general, freight damage claims will be denied if the original packing materials are not retained for the claims adjustor to inspect. Contact a supervisor on how to proceed with filing a freight claim and to order a replacement unit.

**Note:**

Before opening the shipping container, check the container labeling to verify the unit received is the correct unit. Verify the unit capacity, type, and voltage.

### Unpack and Inspect for Freight Damage, continued.

1. Before opening the shipping container, verify the correct unit is included as described in the note on the previous page.
2. Place the box on a solid surface right side up.
3. Cut the white reinforced nylon straps.
4. Open the box.
5. Remove any protective cardboard / Styrofoam® top sheets and place to the side.
6. The walls and top panels are not attached to the bottom of the box. Lift the cardboard carton by the flaps and remove the box walls and top and place it to the side.
7. Remove the moisture barrier plastic bonnet.
8. Check the unit nameplate data and model number. Verify the unit voltage, and capacities are correct before proceeding.
9. Locate and retain all included accessories.
10. Using two people, carefully lift the unit and inspect for freight damage. ⚠ DO NOT lift by the refrigerant piping or drain pipe stub. Lift by the frame only. If damage is found, repack the unit as it was received in the original container.
11. If the unit is undamaged, remove and retain the installation manual.

## Preparing the Installation Area and Hanging the Indoor Unit Frame

### Preparing the Installation Area

1. Installation guide (template) depicts the exact dimensions necessary for the ceiling opening.
2. Choose the location for the indoor unit, and then mark where the suspension bolts, refrigerant piping, and drain hose should be. Suspension bolt angle should account for drain direction.
3. Drill holes for the bolts. Use either a W 3/8 inch or a M10 size bolt.

### Note:

For easier installation, attach the accessories (except for the decoration panel) before hanging the indoor unit.

Figure 6: Using the Level.

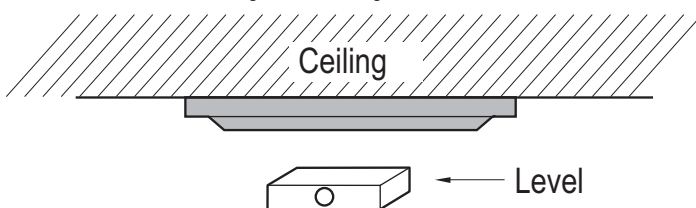

Figure 7: Drilling Holes Using Template.

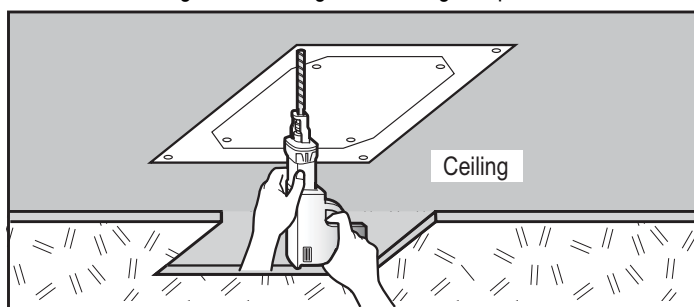

Figure 8: Ceiling Opening Dimensions and Bolt Locations.

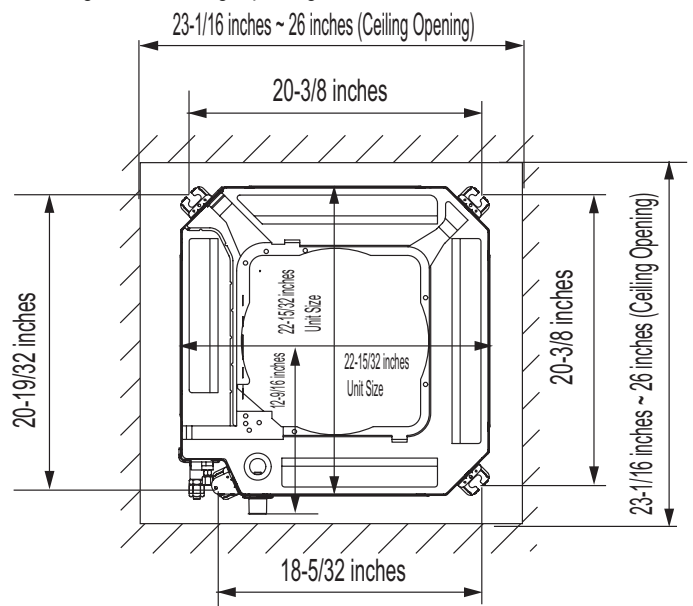

Figure 9: Installing the Hanging Bolt in the Ceiling.

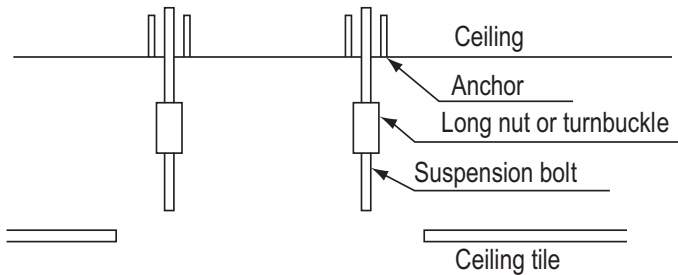
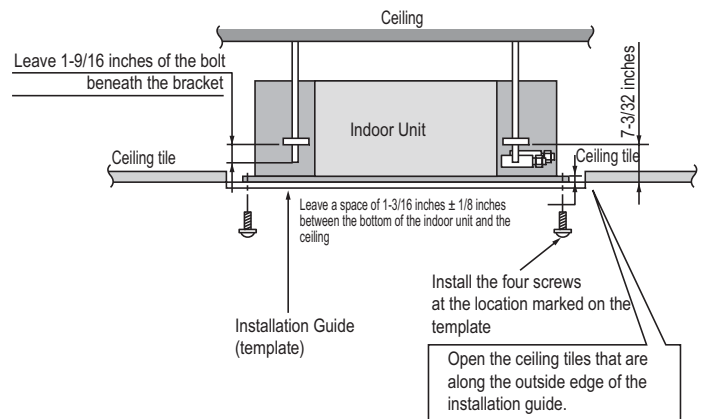

Figure 10: Installation Diagram.



**For New Ceilings**

1. Use a sunken insert, a sunken anchor, or any other field-supplied part to reinforce the ceiling so that it can bear the weight of the indoor unit. Use a temporary washer plate to more easily set up the unit suspension location.
2. Ceiling height is shown on the side of the installation guide (template). Adjust the height of the unit accordingly. Adjust the clearance before hanging the indoor unit.
3. Refer to the installation guide (template) for the dimensions to the ceiling opening. Match the center of the indoor unit (labeled) to the center indicated on the installation guide.
4. Align the installation guide (template) with the label attached to the unit (affixing the template to the unit if desired) to properly place the unit.
5. Remove the temporary washer plate and position the indoor unit hanger brackets on the bolts. Secure with nuts and washers on the top and bottom of the hanger brackets.
6. Ceiling-cassette indoor units are equipped with a built-in drain pump and float switch, therefore, the unit must be installed horizontally or condensate will drip out and cause product malfunction. Measure the unit at each corner to verify that it is level.
7. Remove the installation guide (template).

Figure 11: Hanging the Indoor Unit.

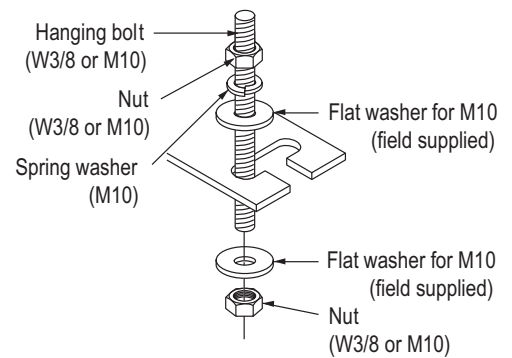

**For Existing Ceilings**

1. Use anchors when installing the indoor unit in an existing ceiling.
2. Ceiling height is shown on the side of the installation guide (template). Adjust the height of the unit accordingly. Adjust the clearance before hanging the indoor unit.
3. Remove the temporary washer plate and position the indoor unit hanger brackets on the bolts. Secure with nuts and washers on the top and bottom of the hanger brackets.
4. Ceiling-cassette indoor units are equipped with a built-in drain pump and float switch, therefore, the unit must be installed horizontally or condensate will drip out and cause product malfunction. Measure the unit at each corner to verify that it is level.
5. Remove the installation guide (template).

## Installing the Drain System

- The unit uses a drain pump with a height of up to 27-9/16 inches to remove condensate from the indoor unit to the drainage system. To ensure proper drainage, the flexible drain piping and any field-supplied drain piping should be installed below the maximum height.
- Field-supplied drain piping must have downward gradient of at least 1/50 to 1/100; to prevent reverse flow, slope should not be straight up and down.
-  Do not damage the drain port on the indoor unit when connecting the flexible drain hose or field-supplied drain piping.
- Drain piping specifications:
  - Indoor Unit Drain Connection (Flexible Drain Hose): 1-1/4 inch outside diameter.

### Note:

The supplied flexible drain hose should not be installed with a sharp curve or twist. A curved or twisted hose may become damaged due to vibration and / or leak.

- Field-Supplied Drain Piping: Polyvinyl chloride piping with 1-inch inside diameter and pipe fittings.

### Note:

Condensate can be drained either directly outside or to a common drain system. For more information regarding the common drain system, see the Multi F / Multi F MAX Outdoor Unit Engineering Manual

If the field drain piping and / or the common drain system is long, it is recommended that clamp hangers be installed for support.

Table 12: Recommended Drain Piping Support Intervals.

Piping Dia. (Inch)	Ø3/4" ~ 1-1/2"	Ø1-1/2" ~ 2"	Ø2-1/2" ~ 5"
Maximum Interval (feet)	<3.3	<3.9	<4.9

## Checking the Drain Pump

The drain pump must be tested before the system operates.

- Connect flexible drain hose to the field-supplied drain piping; leave it as is until the test is complete.
- Pour water into the flexible drain hose and check for leaks.
- After power wiring installation is complete, operate the drain pump to see if it sounds and functions properly.
- After the test is complete, connect the flexible drain hose to the indoor unit drain port.

Figure 12: Ceiling Cassette Indoor Unit Drain System.

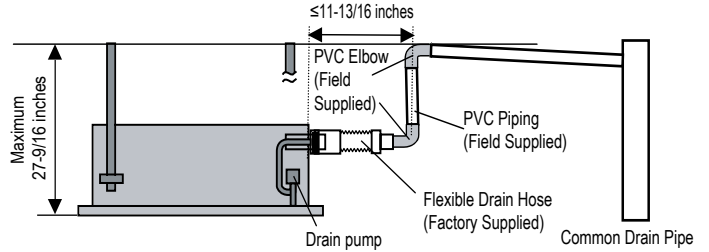

Figure 13: Drain Slope.

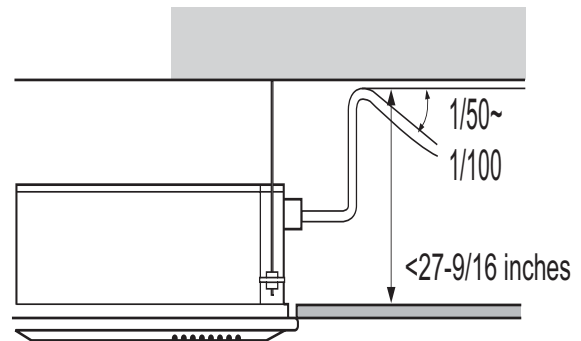

Figure 14: Correct (Another View) and Incorrect Drain Slopes.

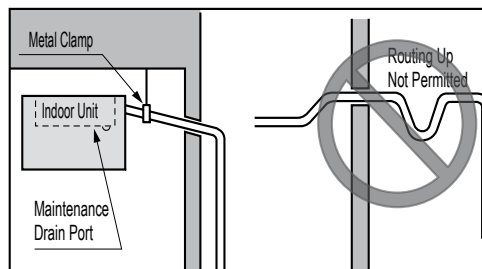
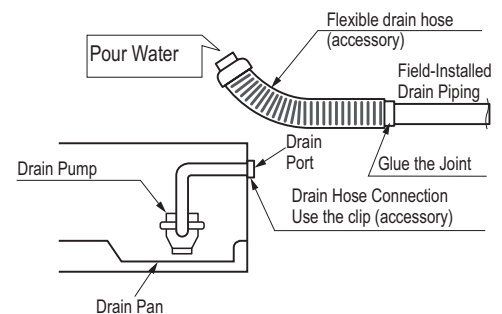

Figure 15: Flexible Drain Hose Connection.



Clamp the Flexible Drain Hose Connection

Figure 16: Checking the Drain Pump.



## Insulating the Drain Piping

- Drain piping insulation should be made of polyethylene foam with a minimum thickness of 7/16 inches.
- Secure drain hose insulation at the drain port connection on the indoor unit so that no gaps exist.

### Note:

LG Electronics U.S.A., Inc., is not responsible for any piping calculations, refrigerant leaks, degradation of performance, or any other potential problems or damages as a result of interconnecting piping, their joint connections, isolation valves, introduced debris inside the piping system, or other problems caused by the interconnecting piping system.

## No Pipe Size Substitutions

Use only the pipe size selected by the LATS Multi F pipe system design software or as conveyed in the product installation instructions. Using a different size is prohibited and may result in a system malfunction or failure to work at all.

## Pipe Slope

The horizontal pipe slope cannot exceed 10° up or down. Y-branches have additional restrictions described on the next page.

## In-line Refrigeration Components

Components such as oil traps, solenoid valves, filter-dryers, sight glasses, tee fittings, and other after-market accessories are not permitted on the refrigerant piping system between the outdoor units and the indoor / branch distribution units.

Multi F / Multi F Max systems have redundant systems that ensure oil is properly returned to the compressor. Sight-glasses and solenoid valves may cause vapor to form in the liquid stream.

### Note:

Over time, dryers may deteriorate and introduce debris into the system. The designer and installer should verify the refrigerant piping system is free of traps, sagging pipes, sight glasses, filter dryers, etc.

## Field-Provided Isolation Ball Valves

LG maintains a neutral position on using isolation valves in VRF refrigerant piping systems. LG does not endorse any manufacturer of isolation valves. It is recognized that installing isolation valves may simplify future maintenance requirements, and, if used, considerations should be taken including, but not limited to, the following:

- Pressure drops for any component used, including isolation valves, must be known in equivalent pipe length and calculated into the total and segment equivalent piping lengths and compared to product design limitations.
- In all cases, materials must be suitable for the application and any applicable codes, including, but not limited to, diameter and wall thickness continuity per ACR standards.

Failure to do so may cause significant performance degradation. Proper leak checks must be performed. Using isolation valves does not automatically void any LG product warranty; however, a limited warranty may be voided in whole or part should any field supplied accessory fail in any way that causes product failure.

## Obstacles

When an obstacle, such as an I-beam or concrete T, is in the path of the planned refrigerant pipe run, it is best practice to route the pipe over the obstacle. If adequate space is not available to route the insulated pipe over the obstacle, then route the pipe under the obstacle. In either case, it is imperative the horizontal section of pipe above or below the obstacle be a minimum of three (3) times greater than the longest vertical rise (or fall) distance.

Figure 17: Insulating the Drain Piping.

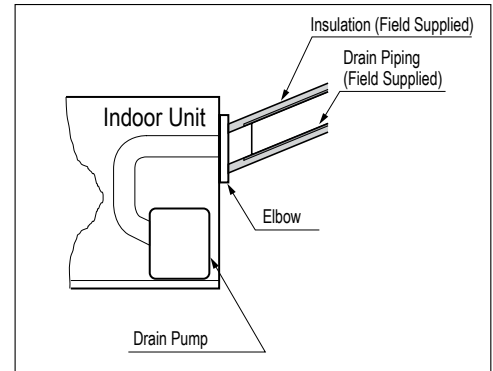
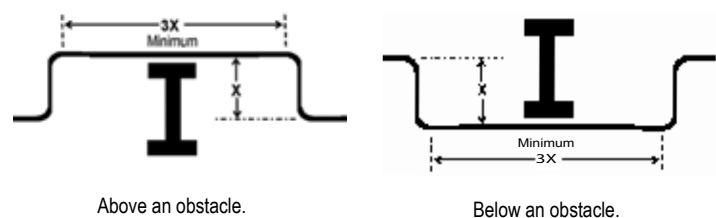

Figure 18: Installing Piping Above and Below an Obstacle.



### Multi F MAX Y-Branch Kit PMBL5620

The LG supplied Y-Branch Kit PMBL5620 MUST be used when two branch distribution units are connected to one Multi F MAX system. Field-supplied fittings are not permitted. Each Y-branch kit comes with two (2) Y-branches (one for the liquid line and one for the vapor line) and insulation covers.

Y-branches may be installed in horizontal or vertical configurations. When installed vertically, position the Y-branch so the straight-through leg is  $\pm 3^\circ$  of plumb. When installed horizontally, position the Y-branch so the take-off leg is level and shares the same horizontal plane as the straight-through leg  $\pm 5^\circ$  rotation.

Y-branches should always be installed with the single port facing the outdoor unit and the two-port end facing the branch distribution units. Do not install Y-branches backwards as refrigerant flow cannot make U-turns. The Y-branch kit must be located at least three (3) feet from the outdoor unit. Provide a minimum of 20 inches between a Y-branch and the branch distribution unit.

Figure 19: Y-Branch Port Identification and Dimensions.

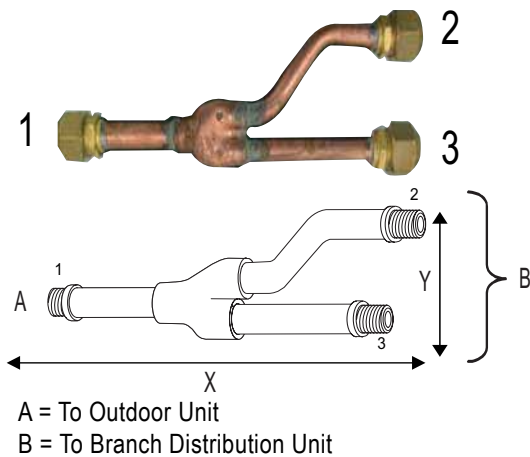
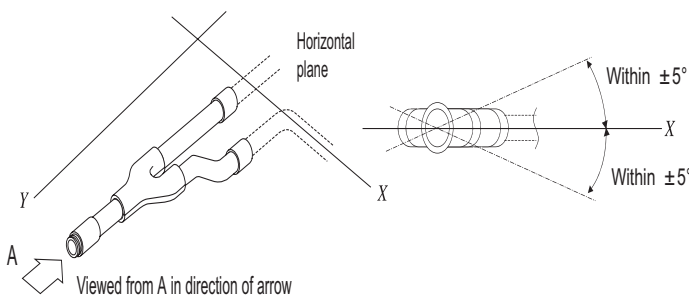

Table 13: Multi F MAX Y-Branch Connection Diameters.

Model	Y-Branch Type	Port Identifier (inch)		
		1	2	3
PMBL5620	Liquid	Ø3/8	Ø3/8	Ø3/8
	Vapor	Ø3/4	Ø3/4	Ø3/4
	Y-Branch Type	Dimensions (inch)		
		X	Y	
	Liquid	13.80	3.24	
	Vapor	12.48	3.02	

Figure 20: Y-branch Horizontal Installation Alignment.



### Y-Branch Kit Insulation

Each Y-branch kit comes with clam-shell type peel-and-stick insulation jackets molded to fit the Y-branch fittings—one for the liquid line, one for the vapor line.

Table 14: Insulation Jacket Properties.

<b>Material</b>	Polyolefin Foam
<b>UL94 Flame Classification</b>	HF-1
<b>Density</b>	1.84 lbs./ft. <sup>3</sup>
<b>Thermal Conductivity</b>	.0208 Btu/h/ft. °R
<b>Thickness</b>	1/2 inch

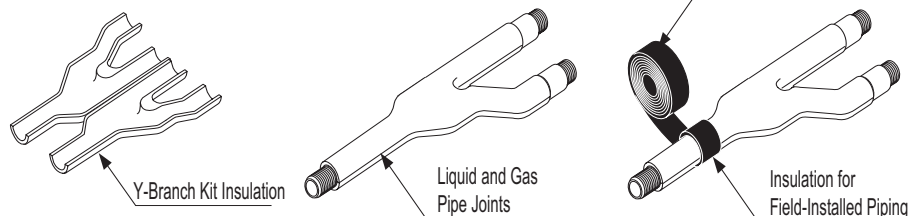

Figure 21: Y-branch Vertical Installation Alignment.

Vertical Up Configuration    Vertical Down Configuration

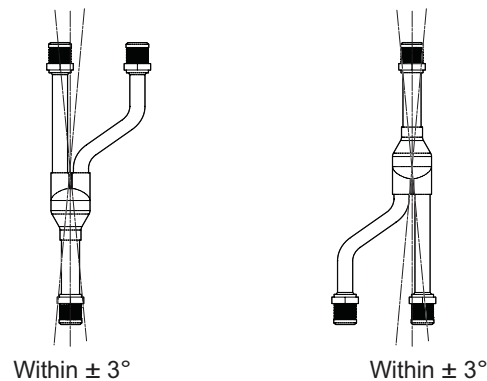

Figure 22: Y-Branch Insulation Jacket Diagram.

**Selecting Field-Supplied Copper Tubing**

Copper is the only approved refrigerant pipe material for use with Multi F products, and LG recommends seamless phosphorous deoxidized ACR type copper pipe, hard-drawn rigid type “K” or “L”, or annealed-tempered, copper pipe.

- Drawn temper (rigid) ACR copper tubing is available in sizes 3/8 through 2-1/8 inches (ASTM B 280, clean, dry, and capped).
- Annealed temper (soft) ACR copper tubing is available in sizes 1/4 through 2-1/8 inches (ASTM B 280, clean, dry, and capped).

**Note:**

Tube wall thickness should meet local code requirements and be approved for an operating pressure of 551 psi. If local code does not specify wall thickness, LG suggests using tube thickness per table below. When bending tubing, try to keep the number of bends to a minimum, and use the largest radii possible to reduce the equivalent length of installed pipe; also, bending radii greater than ten (10) pipe diameters can minimize pressure drop. Be sure no traps or sags are present when rolling out soft copper tubing coils.

Table 15: ACR Copper Tubing Material.

<b>Type</b>	Seamless Phosphorous Deoxidized
<b>Class</b>	UNS C12200 DHP
<b>Straight Lengths</b>	H58 Temper
<b>Coils</b>	O60 Temper

Table 16: Piping Tube Thicknesses.

<b>OD (in)</b>	1/4	3/8	1/2	5/8	3/4	7/8	1-1/8	1-3/8	1-5/8
<b>Material</b>	Rigid Type “K” or “L” and Soft ACR Acceptable			Rigid Type “K” or “L” Only					
<b>Min. Bend Radius (in)</b>	.563	.9375	1.5	2.25	3.0	3.0	3.5	4.0	4.5
<b>Min. Wall Thickness (in)</b>	.03	.03	.035	.040	.042	.045	.050	.050	.050

Table 17: ACR Copper Tubing Dimensions and Physical Characteristics.<sup>1-4</sup>

Nominal Pipe Outside Diameter (in)	Actual Outside Diameter (in)	Drawn Temper			Annealed Temper		
		Nominal Wall Thickness (in)	Weight (lb/ft)	Cubic ft per Linear ft	Nominal Wall Thickness (in)	Weight (lb/ft)	Cubic ft per Linear ft
1/4	0.250	--	--	--	0.030	0.081	.00020
3/8	0.375	0.030	0.126	.00054	0.032	0.134	.00053
1/2	0.500	0.035	0.198	.00101	0.032	0.182	.00103
5/8	0.625	0.040	0.285	.00162	0.035	0.251	.00168
3/4	0.750	0.042	0.362	.00242	0.042	0.362	.00242
7/8	0.875	0.045	0.455	.00336	0.045	0.455	.00336
1-1/8	1.125	0.050	0.655	.00573	0.050	0.655	.00573

<sup>1</sup>All dimensions provided are in accordance with ASTM B280 – Standard.

<sup>2</sup>Design pressure = 551 psig.

<sup>3</sup>ACR Tubing is available as hard drawn or annealed (soft) and are suitable for use with R410A refrigerant.

<sup>4</sup>The Copper Tube Handbook, 2010, Copper Development Association Inc., 260 Madison Avenue, New York, NY 10016.

**Note:**

- Commercially available piping often contains dust and other materials. Always blow it clean with a dry, inert gas.
- Prevent dust, water or other contaminants from entering the piping during installation. Contaminants can cause mechanical failure.

### No Pipe Size Substitutions

**Note:**

Use only the pipe size recommended by this installation manual. Using a different size is prohibited and may result in system malfunction or failure.

### Copper Expansion and Contraction

Under normal operating conditions, the vapor pipe temperature of a Duct Free System can vary as much as 280°F. With this large variance in pipe temperature, the designer must consider pipe expansion and contraction to avoid pipe and fitting fatigue failures.

Refrigerant pipe along with the insulation jacket form a cohesive unit that expands and contracts together. During system operation, thermal heat transfer occurs between the pipe and the surrounding insulation.

If the pipe is mounted in free air space, no natural restriction to movement is present if mounting clamps are properly spaced and installed. When the refrigerant pipe is mounted underground in a utility duct stacked among other pipes, natural restriction to linear movement is present. In extreme cases, the restrictive force of surface friction between insulating jackets could become so great that natural expansion ceases and the pipe is “fixed” in place. In this situation, opposing force caused by change in refrigerant fluid/vapor temperature can lead to pipe/fitting stress failure.

The refrigerant pipe support system must be engineered to allow free expansion to occur. When a segment of pipe is mounted between two fixed points, provisions must be provided to allow pipe expansion to naturally occur. The most common method is the inclusion of expansion Loop or U-bends. Each segment of pipe has a natural fixed point where no movement occurs. This fixed point is located at the center point of the segment assuming the entire pipe is insulated in a similar fashion. The natural fixed point of the pipe segment is typically where the expansion Loop or U-bend should be.

Linear pipe expansion can be calculated using the following formula:

$$LE = C \times L \times (T_r - T_a) \times 12$$

- LE = Anticipated linear tubing expansion (in.)
- C = Constant (For copper =  $9.2 \times 10^{-6}$  in./in.°F)
- L = Length of pipe (ft.)
- T<sub>R</sub> = Refrigerant pipe temperature (°F)
- T<sub>a</sub> = Ambient air temperature (°F)
- 12 = Inches to feet conversion (12 in./ft.)

1. In Table 18 find the row corresponding with the actual length of the straight pipe segment.
2. Estimate the minimum and maximum temperature of the pipe. In the column showing the minimum pipe temperature, look up the anticipated expansion distance. Do the same for the maximum pipe temperature.
3. Calculate the difference in the two expansion distance values. The result will be the anticipated change in pipe length.

**Example:**

A system is installed and the design shows that there is a 100 foot straight segment of tubing between an indoor unit and the outdoor unit. In heating, this pipe transports hot gas vapor to the indoor units at 120°F. In cooling, the same tube is a suction line returning refrigerant vapor to the outdoor unit at 40°F. Look up the copper tubing expansion at each temperature and calculate the difference.

**Vapor Line**

Transporting Hot Vapor: 100 ft. pipe at 120 °F = 1.40 in.

Transporting Suction Vapor: 100 ft. pipe at 40 °F = 0.40 in.

Anticipated Change in Length: 1.40 in. – 0.40 in. = 1.00 in.

**Liquid Line**

The liquid temperature remains relatively the same temperature; only the direction of flow will reverse. No significant change in length of the liquid line, therefore, is anticipated.

When creating an expansion joint, the joint height should be a minimum of two times the joint width. Although different types of expansion arrangements are available, the data for correctly sizing an Expansion Loop is provided in Table 19. Use soft copper with long radius bends on longer runs or long radius elbows for shorter pipe segments. Using the anticipated linear expansion (LE) distance calculated, look up the Expansion Loop or U-bend minimum design dimensions. If other types of expansion joints are chosen, design per ASTM B-88 Standards.

See table below for precalculated anticipated expansion for various pipe sizes and lengths of refrigerant tubing.

**To find the anticipated expansion value:**

1. From the table below, find the row corresponding with the actual feet of the straight pipe segment.
2. Estimate the minimum and maximum temperature of the pipe.
3. In the column showing the minimum pipe temperature, look up the anticipated expansion distance corresponding to the segment length. Do the same for the maximum pipe temperature.
4. Calculate the difference in the two expansion distance values. The result will be the change in pipe length.

Table 18: Linear Thermal Expansion of Copper Tubing in Inches.

Pipe Length <sup>1</sup>	Fluid Temperature °F																			
	35°	40°	45°	50°	55°	60°	65°	70°	75°	80°	85°	90°	95°	100°	105°	110°	115°	120°	125°	130°
10	0.04	0.04	0.05	0.06	0.06	0.07	0.08	0.08	0.09	0.09	0.10	0.10	0.11	0.11	0.11	0.12	0.13	0.14	0.15	0.15
20	0.08	0.08	0.10	0.12	0.13	0.14	0.15	0.16	0.17	0.18	0.19	0.20	0.21	0.22	0.22	0.23	0.26	0.28	0.29	0.30
30	0.12	0.12	0.15	0.18	0.20	0.21	0.23	0.24	0.26	0.27	0.29	0.30	0.32	0.33	0.32	0.35	0.39	0.42	0.44	0.45
40	0.16	0.16	0.20	0.24	0.26	0.28	0.30	0.32	0.34	0.36	0.38	0.40	0.42	0.44	0.43	0.46	0.52	0.56	0.58	0.60
50	0.20	0.20	0.25	0.30	0.33	0.35	0.38	0.40	0.43	0.45	0.48	0.50	0.53	0.55	0.54	0.58	0.65	0.70	0.73	0.75
60	0.24	0.24	0.30	0.36	0.39	0.42	0.45	0.48	0.51	0.54	0.57	0.60	0.63	0.66	0.65	0.69	0.78	0.84	0.87	0.90

<sup>1</sup>Pipe length baseline temperature = 0°F. "Expansion of Carbon, Copper and Stainless Steel Pipe," *The Engineers' Toolbox*, www.engineeringtoolbox.com.

Figure 23: Coiled Expansion Loops and Offsets.

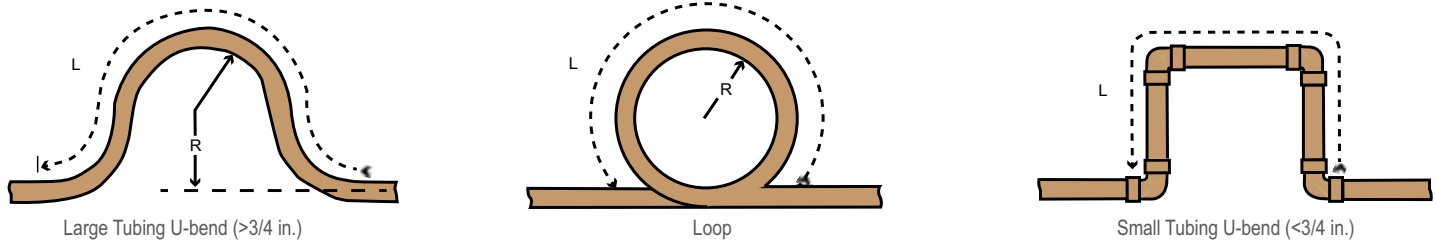

Table 19: Radii of Coiled Expansion Loops and Developed Lengths of Expansion Offsets.

Anticipated Linear Expansion (LE) (inches)		Nominal Tube Size (OD) inches			
		1/4	3/8	1/2	3/4
1/2	R <sup>1</sup>	6	7	8	9
	L <sup>2</sup>	38	44	50	59
1	R <sup>1</sup>	9	10	11	13
	L <sup>2</sup>	54	63	70	83
1-1/2	R <sup>1</sup>	11	12	14	16
	L <sup>2</sup>	66	77	86	101
2	R <sup>1</sup>	12	14	16	19
	L <sup>2</sup>	77	89	99	117
2-1/2	R <sup>1</sup>	14	16	18	21
	L <sup>2</sup>	86	99	111	131
3	R <sup>1</sup>	15	17	19	23
	L <sup>2</sup>	94	109	122	143
3-1/2	R <sup>1</sup>	16	19	21	25
	L <sup>2</sup>	102	117	131	155
4	R <sup>1</sup>	17	20	22	26
	L <sup>2</sup>	109	126	140	166

# GENERAL INSTALLATION GUIDELINES

## Refrigerant Piping

**MULTI F**  
**MULTI F MAX**

### Inserts and Pipe Supports

#### Inserts

An insert can be installed into a floor or beam before the concrete sets so that fittings such as ducts, pipes, or suspension bolts can be added at a later time. Decide where the inserts should be placed before support installation.

#### Pipe Supports

##### Note:

*The pipe system must be adequately supported to avoid pipe sagging. Sagging pipes become oil traps that lead to equipment malfunction.*

Pipe supports should never touch the pipe wall; supports should be installed outside (around) the primary pipe insulation jacket. Insulate the pipe before installing the supports. Pipe supports are field-provided and must meet local code. If local codes do not specify pipe support spacing, install pipe supports a maximum of five (5) feet on center for straight segments of pipe up to 3/4" outside diameter size.

Wherever the pipe changes direction, place a hanger within twelve (12) inches on one side and within twelve to nineteen (12 to 19) inches of the bend on the other side. Support piping at indoor units as shown. Support Y-branch fittings as shown.

Figure 24: Installing an Insert Into a Concrete Beam.

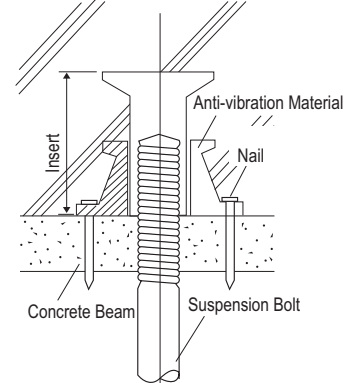

Figure 25: Pipe Hanger Details.

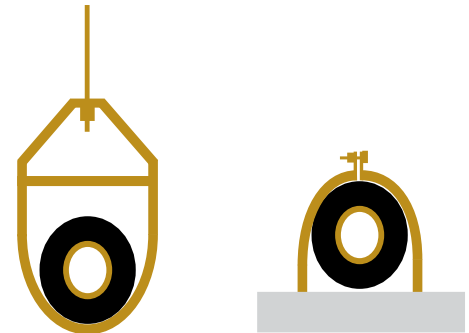

Figure 26: Typical Pipe Support Location—Change in Pipe Direction.

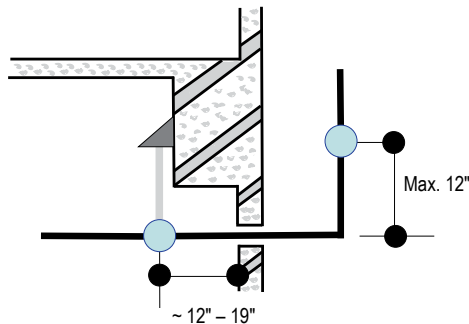

Figure 27: Pipe Support at Indoor Unit.

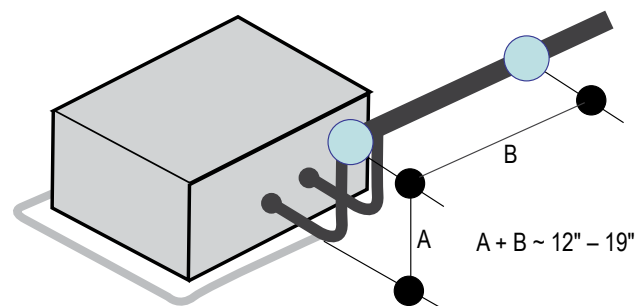
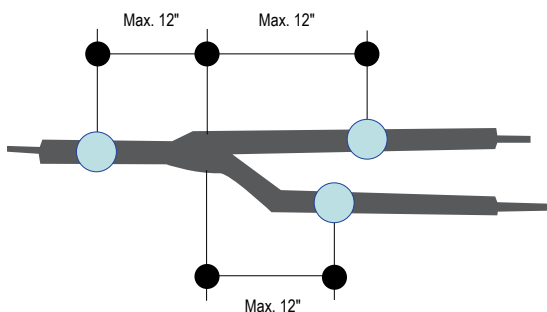

Figure 28: Pipe Support at Y-branch Fitting.



Examples of Supports

Figure 29: U-Bolt Support with Insulation.

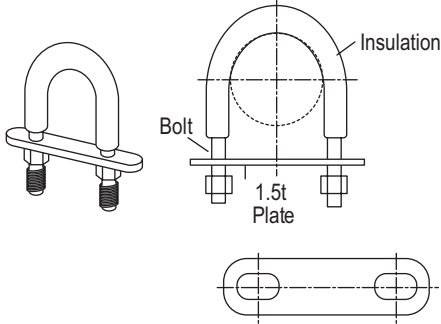

Figure 30: O-Ring Support with Insulation.

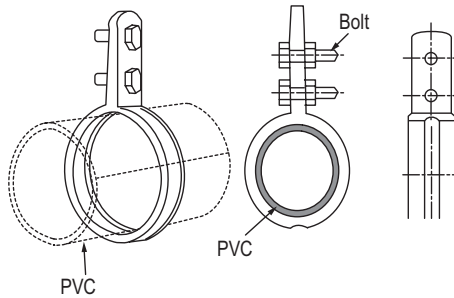
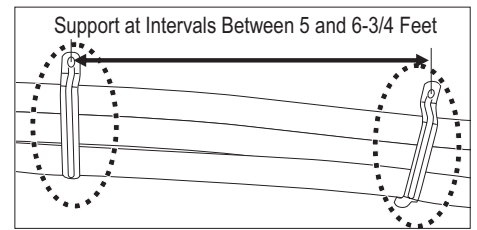

Figure 31: Saddle-Type Support.



**Note:**

⊗ Do not compress the insulation with the saddle-type support. If the insulation is compressed, it may tear open and allow condensation to generate during product operation.

Figure 32: U-Bolt Support with an Insulated Pipe.

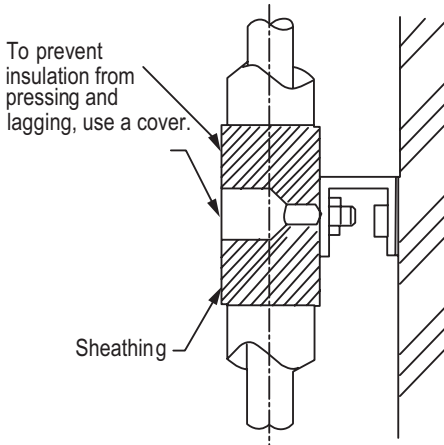

Figure 33: O-Ring Band Support with an Insulated Pipe.

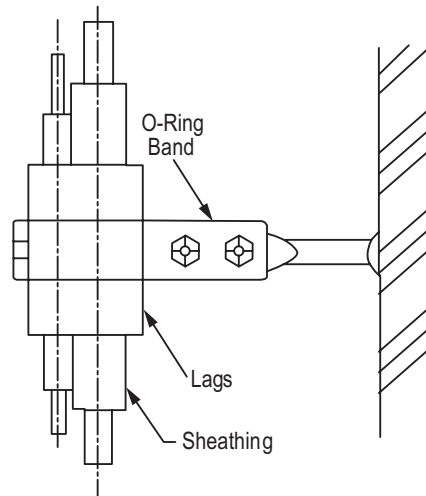

Figure 34: One-Point Down-Stop Support (>441 lbs.).

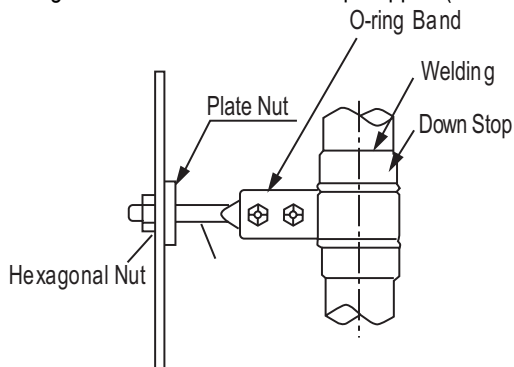
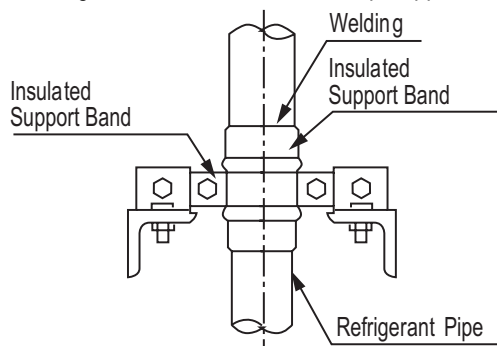

Figure 35: Two-Point Down-Stop Support.



### Pipe Sleeves at Penetrations

LG requires that all pipe penetrations through walls, floors, and pipes buried underground be routed through a properly insulated sleeve that is sufficiently sized to provide free movement of the pipe and does not compress the insulation. Route underground refrigerant pipe inside a protective sleeve to prevent insulation deterioration. Follow federal, state, and local regulations and codes when choosing a sleeve type.

#### Note:

Pipe diameter plus insulation thickness determines wall penetration diameter.

#### For example:

Diameter of Gas Piping:	1/2"
Diameter of Liquid Piping:	1/4"
Thickness of Gas Piping Insulation:	0.4" x 2
Thickness of Liquid Piping Insulation:	0.4" x 2
Surplus:	0.8"
Sleeve diameter (total):	3.1" minimum

Figure 36: Pipe Sleeve Options.

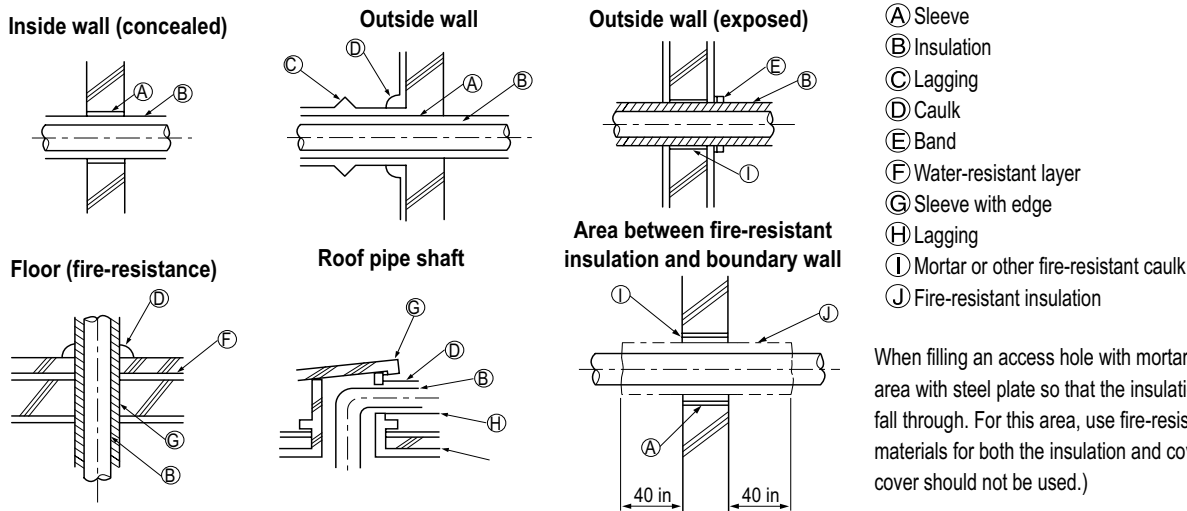

When filling an access hole with mortar, cover the area with steel plate so that the insulation will not fall through. For this area, use fire-resistant materials for both the insulation and cover. (Vinyl cover should not be used.)

### Underground Refrigerant Piping

Route refrigerant pipe installed underground inside a vapor tight protective sleeve to prevent insulation deterioration and water infiltration. Refrigerant pipe installed inside underground casing must be continuous without any joints. Underground refrigerant pipe must be located at a level below the frost line.

Table 20: Utility Conduit Sizes.

Liquid Pipe <sup>1</sup>	Vapor Pipe <sup>1</sup>			
	3/8 (1-1/8 <sup>2,3</sup> )	1/2 (2.0 <sup>2,5</sup> )	5/8 (2-1/8 <sup>2,5</sup> )	3/4 (2-1/4 <sup>2,5</sup> )
1/4 (1.0) <sup>3</sup>	4	4	4	4
3/8 (1-1/8) <sup>3</sup>	4	4	4	5

<sup>1</sup>OD pipe diameter in inches; Values in parenthesis ( ) indicate OD of pipe with insulation jacket.

<sup>2</sup>Diameter of pipe with insulation. Thickness of pipe insulation is typical. Actual required thickness may vary based on surrounding ambient conditions and should be calculated and specified by the design engineer.

<sup>3</sup>Insulation thickness (value in parenthesis) = 3/8 inch.

<sup>4</sup>Insulation thickness (value in parenthesis) = 1 inch.

<sup>5</sup>Insulation thickness (value in parenthesis) = 3/4 inch.

Figure 37: Typical Arrangement of Refrigerant Pipe and Cable(s) in a Utility Conduit.

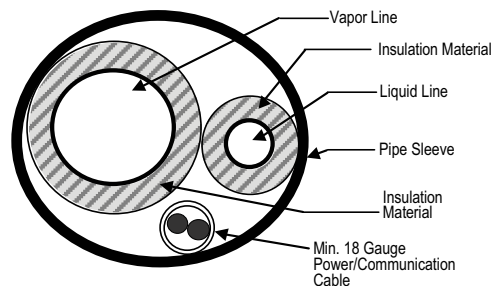

Figure 38: Underground Refrigerant Piping.



### Piping Materials and Handling

Pipes used for the refrigerant piping system must include the specified thickness, and the interior must be clean.

While handling and storing, do not bend or damage the pipes, and take care not to contaminate the interior with dust, moisture, etc. See Table 21 for care of piping.

Figure 39: Keep Piping Capped While Storing.

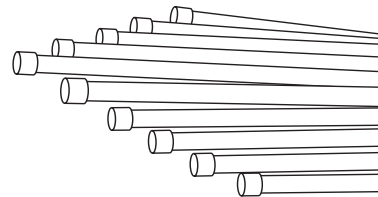
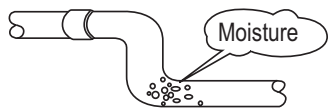

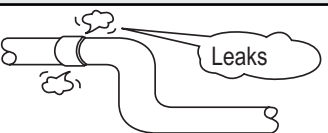

Table 21: Three Principles of Refrigerant Piping.

	Dry	Clean	Airtight
<b>Principles</b>	No moisture should be inside the piping.	No dust should be inside the piping.	No leaks should occur.
			
<b>Problems Caused</b>	<ul style="list-style-type: none"> <li>- Significant hydrolysis of refrigerant oil.</li> <li>- Refrigerant oil degradation.</li> <li>- Poor insulation of the compressor.</li> <li>- System does not operate properly.</li> <li>- EEVs, capillary tubes are clogged.</li> </ul>	<ul style="list-style-type: none"> <li>- Refrigerant oil degradation.</li> <li>- Poor insulation of the compressor.</li> <li>- System does not operate properly.</li> <li>- EEVs and capillary tubes become clogged.</li> </ul>	<ul style="list-style-type: none"> <li>- Refrigerant gas leaks / shortages.</li> <li>- Refrigerant oil degradation.</li> <li>- Poor insulation of the compressor.</li> <li>- System does not operate properly.</li> </ul>
<b>Solutions</b>	<ul style="list-style-type: none"> <li>- Remove moisture from the piping.</li> <li>- Piping ends should remain capped until connections are complete.</li> <li>- Do not install piping on a rainy day.</li> <li>- Connect piping properly at the unit's side.</li> <li>- Remove caps only after the piping is cut, the burrs are removed, and after passing the piping through the walls.</li> <li>- Evacuate system to a minimum of 500 microns and ensure the vacuum holds at that level for 24 hours.</li> </ul>	<ul style="list-style-type: none"> <li>- Remove dust from the piping.</li> <li>- Piping ends should remain capped until connections are complete.</li> <li>- Connect piping properly at the side of the unit.</li> <li>- Remove caps only after the piping is cut and burrs are removed.</li> <li>- Retain the cap on the piping when passing it through walls, etc.</li> </ul>	<ul style="list-style-type: none"> <li>- Test system for air tightness.</li> <li>- Perform brazing procedures that comply with all applicable standards.</li> <li>- Perform flaring procedures that comply with all applicable standards.</li> <li>- Perform flanging procedures that comply with all applicable standards.</li> <li>- Ensure that refrigerant lines are pressure tested to 550 psig.</li> </ul>

### Piping Preparation

#### ⚠ WARNING

- Do not allow the refrigerant to leak during brazing; if refrigerant combusts, it generates a toxic gas which can cause physical injury or death.
- Do not braze in an enclosed location, and always test for gas leaks before / after brazing. Gas leaks can cause physical injury or death.
- After brazing, check for refrigerant gas leaks. Refrigerant gas leaks can cause physical injury or death.
- When selecting flare fittings, always use a 45° fitting rated for use with high pressure refrigerant R410A. Failure to do so may result in refrigerant leaks which in turn could result in personal injuries or death from oxygen depletion. Selected fittings must also comply with local, state, or federal standards.

#### Note:

1. If piping becomes kinked due to excessive bending, do not use the pipe.
2. Braze the pipes to the service valve pipe stub of the outdoor unit.

#### Creating a Flare Fitting

#### Note:

One of the main causes of refrigerant leaks is defective flared connections. Be sure to properly form the flare connections.

1. Cut the pipe to length.
  - Measure the distance between the indoor unit and the outdoor unit.
  - Cut the pipes a little longer than measured distance.
  - Cut the cable 4.9 ft longer than the pipe length.
- 2A. Remove the burrs.
  - Completely remove all burrs from pipe ends.
  - When removing burrs, point the end of the copper pipe down to avoid introducing foreign materials in the pipe.
- 2B. Slide the flare nut onto the copper tube.
3. Flaring the pipe end.
  - Use the proper size flaring tool to finish flared connections as shown.
  - Refer to the diagram in step 3 of Figure 40 and the dimensions in Table 22 for positioning the pipe in the flaring tool.
  - ALWAYS create a 45° flare when working with R410A. See Warning on this page.
4. Carefully inspect the flared pipe end.
  - Compare the flare with the illustration in step 4 of Figure 40.
  - If the flare is defective, cut it off and re-do procedure.
  - If flare looks good, blow clean the pipe with dry nitrogen.

Figure 40: Creating a Flare Fitting.

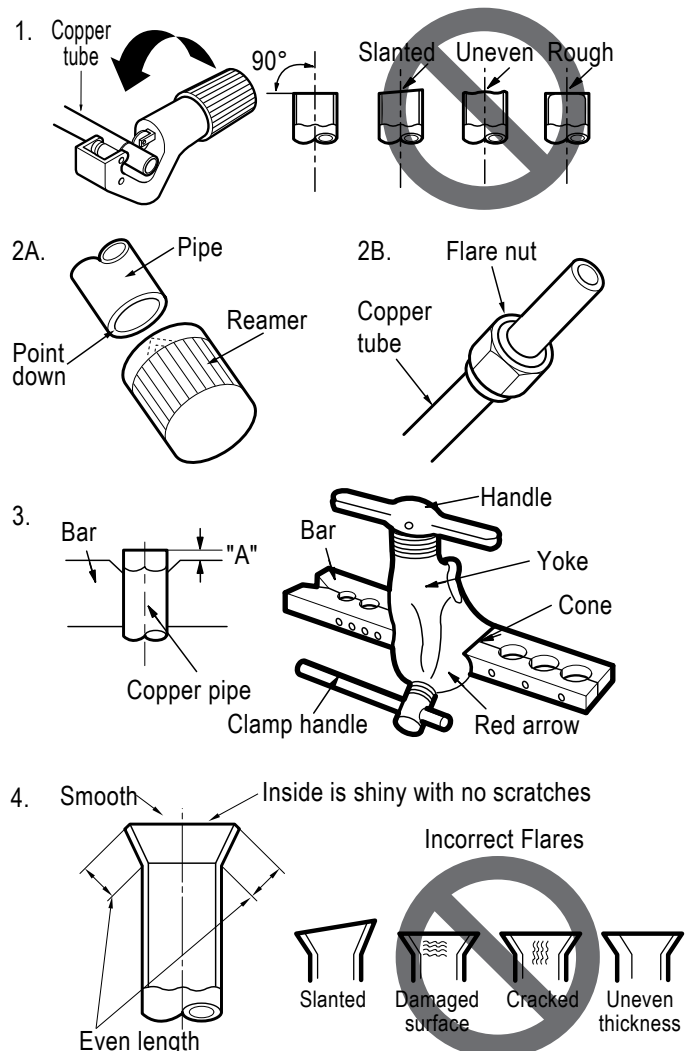

Table 22: Flare "A" Measurement.

Pipe Outside Diameter (inch)	"A" Measurement (inch)
1/4	0.04 – 0.5
3/8	0.06 – 0.7
1/2	0.06 – 0.7
5/8	0.06 – 0.7
3/4	0.07 – 0.8

**Tightening the Flare**

**Note:**

⊘ Do not use polyolyester (POE) or any other type of mineral oil as a thread lubricant. These lubricants are not compatible with PVE oil used in this system and create oil sludge leading to equipment damage and system malfunction.

1. When connecting the flare nuts, coat the flare (inside and outside) with polyvinyl ether (PVE) refrigeration oil only.
2. Align the center of the piping sections and tighten the flare nut by hand.
3. Tighten the flare nut with a torque wrench and a backup wrench until a click is heard.
4. Wrap insulation around the connection.
5. If it is necessary to loosen the flare nuts, always use two wrenches to do so.

Table 23: Tightening Torque for Flare Nuts.

Pipe size (Inches O.D.)	Tightening torque (ft-lbs)	Width of the flare (A [inches])
1/4Ø	13.9 - 18	1/8
3/8Ø	24.5 - 30.3	1/8
1/2Ø	39.7 - 47.7	1/8
5/8Ø	45.5 - 59.2	1/16

**Multi F Outdoor Unit to Indoor Unit Piping Connections**

**Avoid Pipe Damage**

- When routing field-provided piping, avoid damaging the outdoor unit from excessive vibration.
- Correctly route the piping so it does not make contact with mounting bolts. Allow room for field installation.
- Properly insulate the liquid and gas lines separately up to the point of connection at the unit frame.
- See table below for Multi F outdoor unit connection types.

Table 24: Outdoor Unit Piping Connections.

Outdoor Unit Piping Connections	LMU18CHV	LMU24CHV	LMU30CHV	LMU36CHV
Liquid Line Connection (in., OD) x Qty.	1/4 x 2	1/4 x 3	1/4 x 3	1/4 x 4
Vapor Line Connection (in., OD) x Qty.	3/8 x 2	3/8 x 3	3/8 x 3	3/8 x 4

Table 25: Ceiling Cassette Indoor Unit Pipe Sizes.

Indoor Unit Capacity	Vapor Line Size (in., OD)	Liquid Line Size (in., OD)
7,000 Btu/h	Ø3/8	Ø1/4
9,000 Btu/h		
12,000 Btu/h		
18,000 Btu/h	Ø1/2	

Table 26: Ceiling Cassette Indoor Unit Piping Connections.

Indoor Unit Capacity	Vapor Line Connection (in., OD)	Liquid Line Connection (in., OD)
7,000 Btu/h	Ø3/8	Ø1/4
9,000 Btu/h		
12,000 Btu/h		
18,000 Btu/h	Ø1/2	

Figure 41: Multi F Refrigerant Pipe Connections (LMU36CHV shown as example).

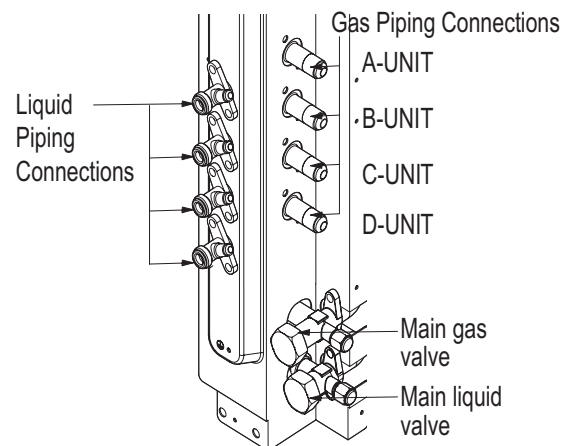

# PIPING CONNECTIONS

IDU to ODU

**MULTI F**  
**MULTI F MAX**

## Multi F Outdoor Unit to Indoor Unit Piping Connections, continued.

Connection sockets (included as a factory-supplied accessory with the indoor units) may need to be used when piping the indoor units to the outdoor unit.

Table 27: Connection Socket Dimensions.

Indoor Unit Capacity	Vapor (in., OD)		Liquid (in., OD)	
	A	B	A	B
18,000 Btu/h	Ø3/8 → Ø1/2		N/A	

### Using the Connection Socket

1. Align the center of the piping sections and tighten the flare nut by hand.
2. Tighten the flare nut with a torque wrench, using the arrows on the wrench as a guide, until a click is heard.

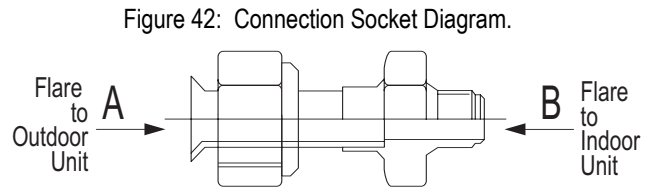
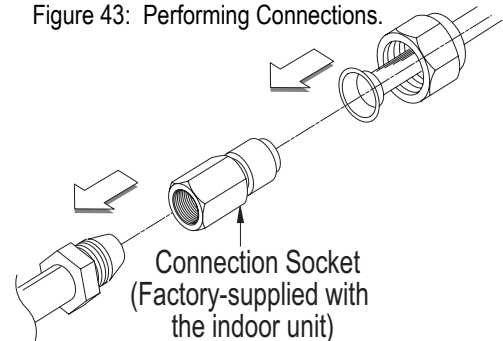

Figure 43: Performing Connections.



## Multi F MAX Outdoor Unit System Piping Connections

### Note:

#### Avoid Pipe Damage

- When routing field-provided piping, avoid damaging the outdoor unit from excessive vibration.
- Properly insulate the liquid and gas lines separately up to the point of connection at the unit frame.
- See table below for Multi F MAX outdoor unit connection types.

 Correctly route the piping so it does not make contact with mounting bolts. Allow room for field installation.

Table 28: Outdoor Unit Piping Connections.

Outdoor Unit Piping Connections	LMU480HV, LMU540HV, and LMU600HV
Liquid Line Connection (in., OD) x Qty.	3/8 x 1
Vapor Line Connection (in., OD) x Qty.	3/4 x 1

### Branch Distribution to Indoor Unit Piping Connections

- Install indoor unit liquid and vapor refrigerant pipes (and connection wiring) to the appropriate branch distribution ports.
- Clearly note on the indoor unit's refrigerant piping (liquid, vapor) which branch distribution port it is connected to (A, B, C, D).

Table 29: Branch Distribution Unit Piping Connections.

Branch Distribution Unit	PMBD3620	PMBD3630	PMBD3640	PMBD3641
<b>Piping Connections to Outdoor Unit</b>				
Liquid (in., OD) x Qty.	Ø3/8 x 1			
Vapor (in., OD) x Qty.	Ø3/4 x 1			
<b>Piping Connections to Indoor Units</b>				
Liquid (in., OD) x Qty.	Ø1/4 x 2	Ø1/4 x 3	Ø1/4 x 4	Ø1/4 x 3, Ø3/8 x 1
Vapor (in., OD) x Qty.	Ø3/8 x 2	Ø3/8 x 3	Ø3/8 x 4	Ø3/8 x 3, Ø5/8 x 1

Figure 44: Branch Distribution Ports to Indoor Units.

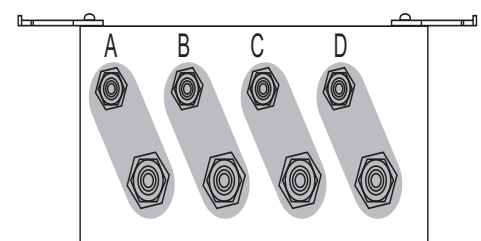

Multi F Ceiling Cassette Indoor Unit

**Multi F MAX Outdoor Unit System Piping Connections, continued.**

Table 30: Ceiling Cassette Indoor Unit Pipe Sizes.

Indoor Unit Capacity	Vapor Line Piping Size (in., OD)	Liquid Line Piping Size (in., OD)
7,000 Btu/h	Ø3/8	Ø1/4
9,000 Btu/h		
12,000 Btu/h		
18,000 Btu/h	Ø1/2	

Table 31: Ceiling Cassette Indoor Unit Piping Connections.

Indoor Unit Capacity	Vapor Line Conn. (in., OD)	Liquid Line Conn. (in., OD)
7,000 Btu/h	Ø3/8	Ø1/4
9,000 Btu/h		
12,000 Btu/h		
18,000 Btu/h	Ø1/2	Ø1/4

Connection sockets (included as a factory-supplied accessory with the indoor units) may need to be used when piping the indoor units to the branch distribution unit.

Table 32: Connection Socket Dimensions.

Indoor Unit Capacity	Vapor (in., OD)		Liquid (in., OD)	
	A	B	A	B
18,000 Btu/h	Ø3/8 → Ø1/2		N/A	

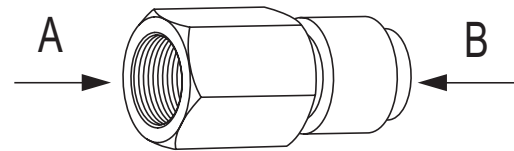

Connection Socket

Figure 46: Possible Outdoor Unit or Branch Distribution Unit (Multi F MAX only) to Indoor Unit Connections.

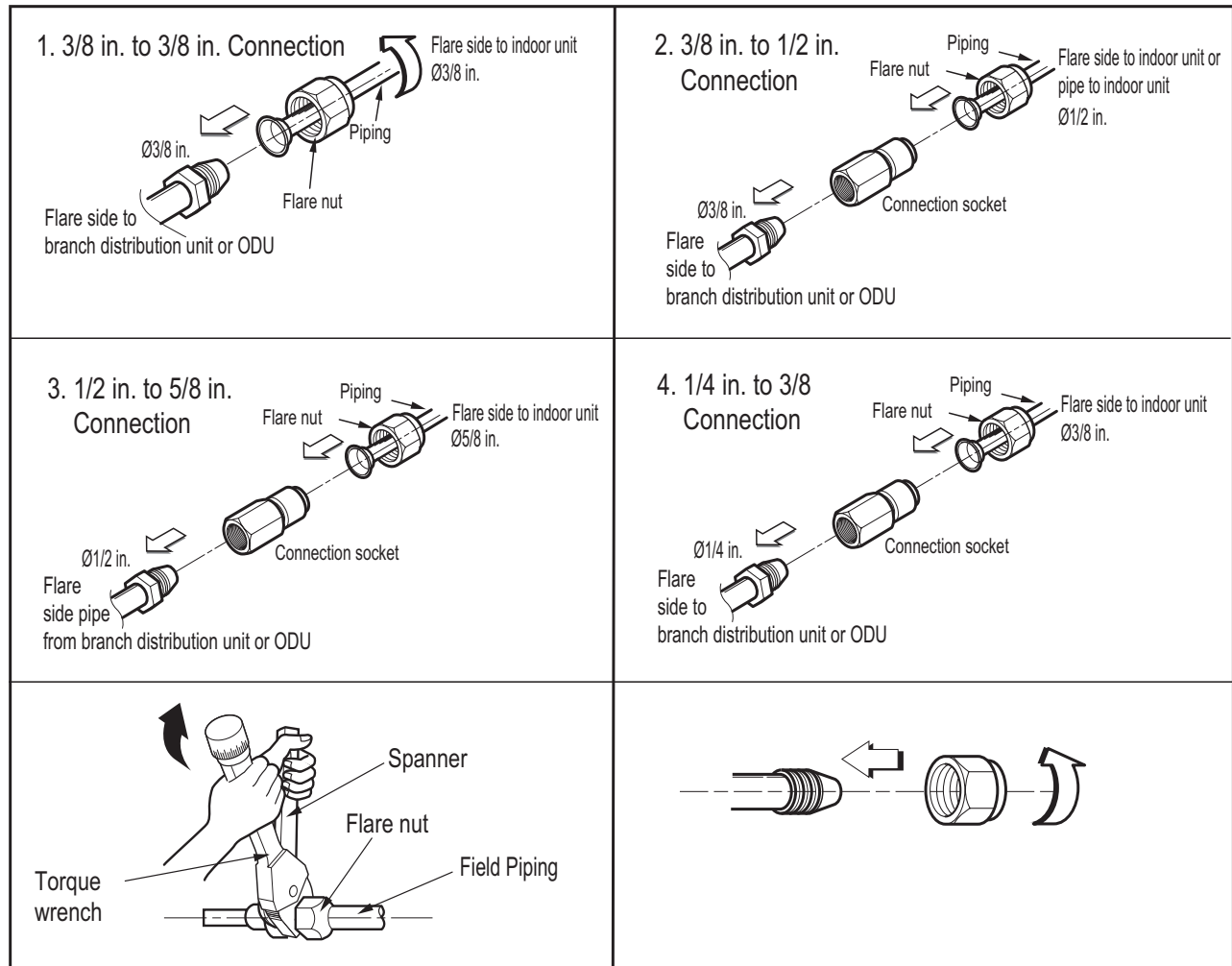

## Refrigerant Safety

### ⚠ WARNING

Verify the maximum refrigerant concentration level in the space where the indoor unit will be installed meets the concentration limit for the application.

ASHRAE Standards 15-2010 and 34-2010 offer guidelines that address refrigerant safety and the maximum allowable concentration of refrigerant in an occupied space. Refrigerant will dissipate into the atmosphere, but a certain volume of air is required for this to occur safely. For R410A refrigerant, the maximum allowable concentration of refrigerant is twenty-six (26) lbs. per 1,000 cubic feet of an occupied space. Buildings with twenty-four (24) hour occupancy allow half of that concentration.<sup>1</sup>

ASHRAE Standards 15 and 34 assume that if a system develops a leak, its entire refrigerant charge will dump into the area where the leak occurs. To meet ASHRAE Standards 15 and 34, calculate the refrigerant concentration that may occur in the smallest room volume on the system, and compare the results to the maximum allowable concentration number.<sup>1</sup> Also consult state and local codes in regards to refrigerant safety.

<sup>1</sup>Information about ASHRAE Standard 15-2010/34-2010 and addenda current as of the date of this publication.

## Brazing

### Note:

It is imperative to keep the piping system free of contaminants and debris such as copper burrs, slag, or carbon dust during installation.

- All joints are brazed in the field. Multi F refrigeration system components contain very small capillary tubes, small orifices, electronic expansion valves, oil separators, and heat exchangers that can easily become blocked. Proper system operation depends on the installer using best practices and utmost care while assembling the piping system.
  - Store pipe stock in a dry place and keep stored pipe capped and clean.
  - Purge all pipe sections clean with dry nitrogen prior to assembly.
- Proper system operation depends on the installer using best practices and the utmost care while assembling the piping system.
  - Use adapters to assemble different sizes of pipe.
  - Always use a non-oxidizing material for brazing. ⚠ Do not use flux, soft solder, or anti-oxidant agents. If the proper material is not used, oxidized film may accumulate and clog or damage the compressors. Flux can harm the copper piping or refrigerant oil.
  - Use a tubing cutter. ⚠ Do not use a saw to cut pipe. De-bur and clean all cuts before assembly.
- Brazing joints:
  - Use a dry nitrogen purge operating at a minimum pressure of three (3) psig and maintain a steady flow.
  - Use a 15% silver phosphorous copper brazing alloy to avoid overheating and produce good flow.
  - Protect isolation valves (if present), electronic expansion valves, and other heat-sensitive control components from excessive heat with a wet rag or heat barrier spray.

Figure 47: Using Nitrogen Gas During Brazing.

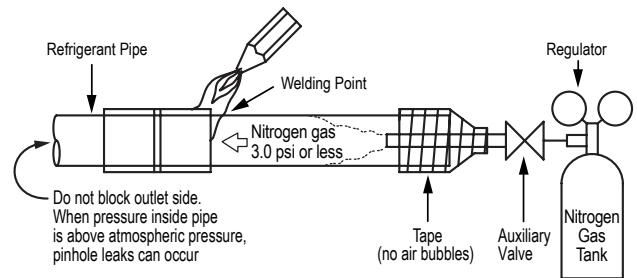

## Refrigerant Piping System Insulation

All refrigerant piping including Y-branch connections, field-provided isolation ball valves, service valves, and elbows must be properly and completely insulated using closed cell pipe insulation (up to the indoor unit piping connections). To prevent heat loss/heat gain through the refrigerant piping, all refrigerant piping including liquid lines and vapor lines must be insulated separately. Insulation must be a minimum 1/2" thick, and thickness may need to be increased based on ambient conditions and local codes. Table 33 lists minimum wall thickness requirements for Ethylene Propylene Diene Methylene (EPDM) insulation.

Inside the outdoor unit, maximum pipe temperature is 248°F and minimum pipe temperature is -40°F. For field insulation of refrigerant piping between outdoor units and indoor units, consider the following pipe temperature ranges for an operating heat pump system:

- Heating mode refrigerant temperature ranges: Liquid 75-118°F; High Pressure Vapor 95-220°F
- Cooling mode refrigerant temperature ranges: Liquid 75-118°F; Low Pressure Vapor 40-90°F

**Note:**

Follow locals codes when selecting EPDM insulation wall thickness. Thickness in Table 33 is based on heat conductivity of 0.61 Btu/in/h/ft<sup>2</sup>/°F.

Table 33: Insulation Guidelines for Typical and Special Circumstances.

Classification		Air-conditioned location		Non-air conditioned location	
		1. Typical location	2. Special location	3. Typical location	4. Special location
Liquid pipe	ø1/4 inches	1/2 inches	1/2 inches	1/2 inches	1/2 inches
	ø3/8 inches				
	≥ø1/2 inches				
Vapor pipe	ø3/8 inches	1/2 inches	3/4 inches	3/4 inches	1 inch
	ø1/2 inches				
	ø5/8 inches				
	ø3/4 inches				

**1. Air-conditioned, Typical location**

- When piping passes through an indoor area where the indoor unit operates, such as an apartment, classroom, office, mall, hospital, etc.

**2. Air-conditioned, Special location**

- When the location is air conditioned, but has severe temp/humidity difference due to high ceilings, such as a church, auditorium, theater, etc.
- When the location is air conditioned, but internal temperature/humidity are high, such as a bathroom, swimming pool, locker room, etc.

**3. Non-air conditioned, Typical location**

- When piping passes through an indoor area where the indoor unit does not operate, such as a hallway, dormitory, or school, etc.

**4. Non-air conditioned, Special location (when both conditions listed below are present)**

- When piping passes through an indoor area where the indoor unit does not operate.
- When the humidity is high and there is no air flow in the location where the piping is installed.

**⚠ WARNING**

Ensure all refrigerant piping is insulated. Any exposed piping will cause burns if touched.

**Note:**

Any exposed piping may generate condensate that may damage walls, etc.; sufficiently insulate all cold surfaces to prevent moisture from forming.

Overlap the insulation at the connection of the field-installed piping and the indoor unit. Tape together so that no gaps exist, and secure insulation to the rear piping housing with vinyl tape.

Ensure insulation material fits snugly against the refrigeration pipe with no air space between the pipe surface and the surrounding insulation.

Protect insulation inside hangers and supports with a second insulation layer. Ensure insulation on all pipe passing through pipe hangers, inside conduit, and/or sleeves is not compressed.

Glue all insulation joints with no air gaps. Be sure insulation material fits snugly against the refrigeration pipe with no air space between it and the pipe. All pipe insulation exposed to the sun and outdoor elements must be properly protected with PVC, aluminum vapor barrier, or alternatively placed in a weather-resistant enclosure such as a pipe rack with a top cover; and must meet local codes. Pay special attention to insulating the pipes installed in a ceiling plenum.

Figure 48: Typical Refrigerant Line Flare Fitting Insulation Detail.

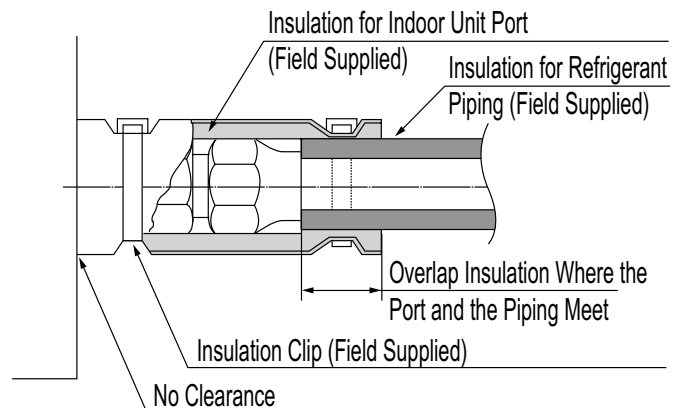

### **⚠ WARNING**

- All power wiring and communication cable installation must be performed by authorized service providers working in accordance with local, state, and National Electrical Code regulations related to electrical equipment and wiring, and following the instructions in this manual.
- Be sure that main power to the unit is completely off before proceeding. Follow all safety and warning information outlined at the beginning of this manual. Failure to do so may cause electric shock and bodily injury.
- Familiarize yourself with the location of the circuit breaker. Be sure that a circuit breaker or some other emergency power cutoff device is in place before any power wiring is done to the system. Failure to do so may cause bodily injury or death.
- ⓧ Never touch any power lines or live cables before all power is cutoff to the system. To do so, may cause bodily injury or death.
- Undersized wiring may lead to unacceptable voltage at the unit and may cause unit malfunction and be a fire hazard.
- Properly ground the outdoor, indoor, and branch distribution (Multi F MAX systems only) units. Ground wiring is required to prevent accidental electrical shock during current leakage.
- Ground wiring must always be installed by a qualified technician.
- Install appropriately sized breakers / fuses / overcurrent protection switches and wiring in accordance with local, state, and National Electrical Code regulations related to electrical equipment and wiring, and following the instructions in this manual. Using an oversized breaker or fuse may result in electric shock, physical injury or death.
- ⓧ Do not connect ground wire to refrigerant, gas, or water piping; to lightning rods; to telephone ground wiring; or to the building plumbing system. Failure to properly provide a National Electrical Code-approved earth ground can result in electric shock, physical injury or death.

### **Note:**

- Consider ambient conditions (temperature, direct sunlight, inclement weather, etc.) when selecting, installing, and connecting the power wiring.
- Properly ground the outdoor, indoor, and branch distribution (Multi F MAX systems only) units. Improperly ground wire can cause communication problems from electrical noise and motor current leakage. Ground wiring must always be installed by a qualified technician.
- If the system operates in reversed phase, it may damage the compressors and other components.
- If there is a possibility of reversed phase, phase loss, momentary blackout, or the power goes on and off while the system is operating, install a field-supplied phase loss protection circuit.
- Install appropriately sized breakers / fuses / overcurrent protection switches and wiring in accordance with local, state, and National Electrical Code regulations related to electrical equipment and wiring, and following the instructions in this manual. Using an oversized breaker or fuse may result in equipment malfunction and property damage.
- ⓧ Do not connect ground wire to refrigerant, gas, or water piping; to lightning rods; to telephone ground wiring; or to the building plumbing system. Failure to properly provide a National Electrical Code-approved earth ground can result in property damage and equipment malfunction.
- ⓧ Do not operate the air conditioning system until the refrigerant piping installation is complete. Operating the system before refrigerant piping is finalized may damage the compressor.
- Use ring terminals to attach the wiring. Verify that all power wiring and communications cable terminals are securely attached. Ensure enough slack is included in the wiring and cables to avoid damaging the connections.
- Use a conduit to protect the power wiring.

## **Multi F / Multi F MAX System Power Wiring and Communications Cable**

For both Multi F and Multi F MAX systems, line voltage is wired to the outdoor unit only. The outdoor unit will supply power to the branch distribution units (Multi F MAX systems only) and the indoor units through the power wiring / communications cable.

### Power Supply / Power Wiring Specifications

**Note:**

- Multi F and Multi F MAX systems operate at 1Ø, 208-230V, 60Hz.
- Power supply, wire type and size should be selected based on National Electrical Code and local codes. Maximum allowable voltage fluctuation  $\pm 10\%$  or nameplate rated value.
- Properly ground the outdoor units per National Electrical Code and local codes.
- For power to the outdoor units, use field-supplied copper wiring that is solid or stranded, and shielded with the wires separately insulated.
- Ground wire should be longer than the common power / communication wires.
- Connect the wiring firmly so the wires cannot be easily pulled out.
- Refer to the inside of the chassis cover for circuit and terminal block diagrams for your model unit.
- Always match color codes of each wire and follow wiring diagram.

### General Communication Cable Specifications

- Multi F Systems: All power wiring / communication cable to be minimum 18 AWG from the outdoor unit to the indoor unit, stranded, shielded or unshielded (if shielded, it must be grounded to the chassis of the outdoor unit only), and must comply with applicable local and national codes.
- Multi F MAX Systems: All power wiring / communication cable to be minimum 16 AWG from the outdoor unit to the BD unit, and 18 AWG from the BD unit to the indoor unit, stranded, shielded or unshielded (if shielded, it must be grounded to the chassis of the outdoor unit only), and must comply with applicable local and national codes.
- For power / communication wires between the Multi F and Multi F MAX outdoor units and the indoor units / BD units (Multi F MAX systems only), use a four (4) conductor, stranded, shielded or unshielded wire. If shielded, the wire must be grounded to the chassis at the outdoor unit only.
- Insulation material as required by local code.
- Rated for continuous exposure of temperatures up to 140°F.
- Firmly attach the cable; provide slack but secure in a way to prevent external forces from being imparted on the terminal block.
- Wiring should be completed without splices.

Figure 49: Multi F / Multi F MAX Outdoor and Indoor / Branch Distribution Unit Wiring and Communications Cable Diagram.

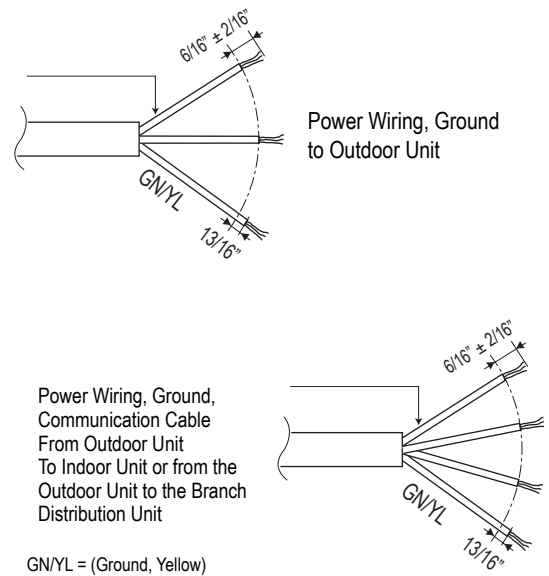

Installation Manual

Figure 50: Close up of a Typical Ring Terminal.

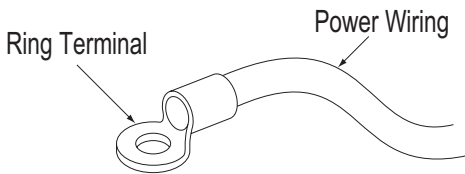
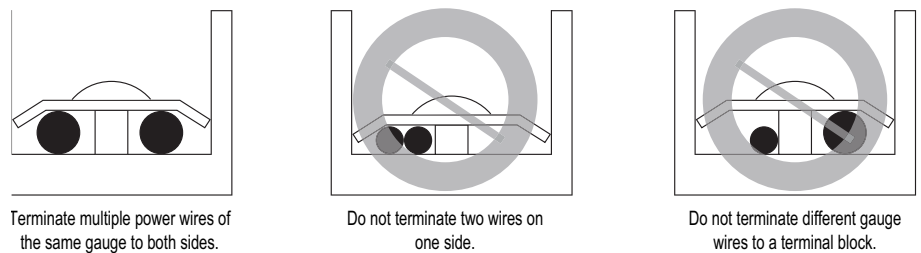

Figure 51: Proper and Improper Power Wiring Connections.



**⚠ WARNING**

If power wires are not properly terminated and firmly attached, there is risk of fire, electric shock, and physical injury or death.

### Note:

- Always verify the communication cable is connected to a communications terminal. ⚠ Never apply line voltage power to the communication cable connection. If contact is made, the PCBs may be damaged.
- Always include some allowance in the wiring length when terminating. Provide some slack to facilitate removing the electrical panels while servicing.
- The shield of the communications cable connecting the outdoor unit to the indoor units should be grounded only to the outdoor unit frame.
- Tie the shield of each cable segment together using a wire nut at the indoor unit. Maintain polarity throughout the communication network.
- Position the incoming power to the outdoor unit away from the power / communications cables from the outdoor unit to the indoor unit / branch distribution unit (Multi F MAX systems only).
- ⚠ Never use a common multiple-core communications cable. Each communications bus shall be provided a separate cable (i.e., between outdoor unit and indoor unit).
- ⚠ Never ground the shield of the communications cable to the indoor unit frame or other grounded entities of the building. Ground the communications cable shield only at the outdoor unit. Improperly grounding this cable can cause communications errors.

## Controller Options

Refer to the table at bottom right as to which remote controller model is used for each indoor unit. After all wiring is connected to the indoor and outdoor units, be sure to test the accompanying remote controllers for performance. As always, follow all safety warnings and notes when operating the units using the remote controller. Additionally, all of the Multi F / Multi F Max outdoor models can use the following controllers when accompanied with the PI 485 VNet Accessory:

- AC Smart
- ACP
- BACnet®
- LonWorks®
- LGMV

Table 34: Multi F Cassette Wireless Controller Model.

Wireless Controller Model
AKB73757604

BACnet® is a registered trademark of ASHRAE. LonWorks® is a registered trademark of Echelon Corporation.

\*Wireless Handheld Controller for the four-way ceiling cassette indoor units is also referenced by Model No. PQWRHQ0FDB.

## Power Wiring / Communications Cable Installation Guidelines

- These instructions are for the indoor unit only. For outdoor unit wiring, refer to the outdoor unit installation manual.
- Confirm power source specifications.
- Confirm that the electrical capacity is sufficient.
- Starting current must be maintained  $\pm 10$  percent of the rated current marked on the outdoor unit name plate.
- Confirm cable thickness specifications.
- It is recommended that a circuit breaker is installed, especially if conditions could become wet or moist.
- Include a disconnect in the power wiring system. Add an air gap contact separation of at least 1/8 inch in each active (phase) conductor.
- A voltage drop may cause the following problems:
  1. Magnetic switch vibration, fuse breaks, or disturbance to the normal function of an overload protection device.
  2. Compressor will not receive the proper starting current.

The general guidelines for connecting electrical and communication cables are similar for all ceiling cassette indoor units. The electrical connections procedure includes a wiring diagram for the ceiling cassette indoor unit. It is recommended that power wiring / communications cable installation be performed before decorative grille kit (required; sold separately) installation.

**⚠ WARNING**

- Be sure that main power to the unit is completely off before beginning this procedure. Electric shock can cause severe physical injury or death.
- Follow all safety and warning information outlined at the beginning and throughout this manual. Failure to do so may cause bodily injury or death.
- Loose wiring may cause unit malfunction, or the terminal to overheat and catch fire, causing physical injury.

**Note:**

- Follow all safety and warning information outlined at the beginning and throughout this manual. Failure to do so, may cause unit failure.
- Ceiling cassette units require removing the control cover from the terminal block area. Control covers are attached with a phillips screw head.
- Connect the electrical cable to the indoor unit by connecting the wires to the terminals on the control board individually according to the outdoor unit connection. Be sure that the color of the wires at the outdoor unit / BD unit (Multi F MAX systems only) along with the terminal numbers are the same as those for the indoor unit. If wiring is not performed correctly, the system will malfunction.
- Terminal screws may become loose during transport. Properly tighten the terminal connections during installation.

**Connecting the Power Wiring and Communications Cable**

1. To access the terminal block, unscrew the control box cover and set it aside.
2. Insert the power wiring / communications cable from the outdoor unit or branch distribution unit (Multi F MAX systems only) through the sides of the indoor unit and control box. Pass the wiring through the designated access holes to prevent damage. To prevent electromagnetic interference and product malfunction, leave a space between the power wiring and communications cable outside of the indoor unit.
3. Connect each wire to its appropriate terminal on the indoor unit control board. Verify that the color and terminal numbers from the outdoor unit or branch distribution unit (Multi F MAX systems only) wiring match the color and terminal numbers on the indoor unit.
4. Neatly arrange power wiring / communications cable and secure with the appropriate cable restraint. When clamping, do not apply force to the wiring connections.
5. Firmly reattach the control box cover, do not catch the wiring in the electric box cover and make sure the cover firmly closes.
6. Fill in any gaps around the wiring access holes with sealant to prevent foreign particles from entering the indoor unit.

Figure 52: Power Wiring and Communications Cable Connection Access.

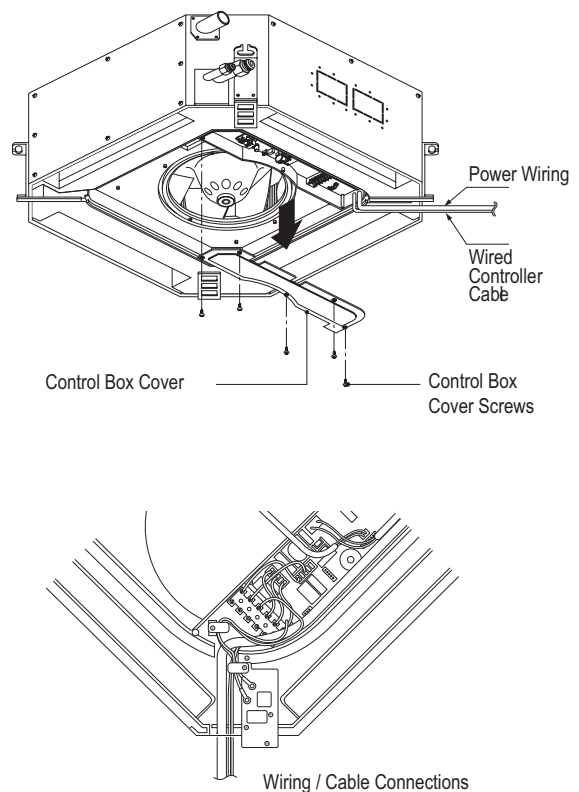

Figure 53: Simplified View of Indoor Unit to Outdoor Unit / Branch Distribution Unit Terminal Connections.

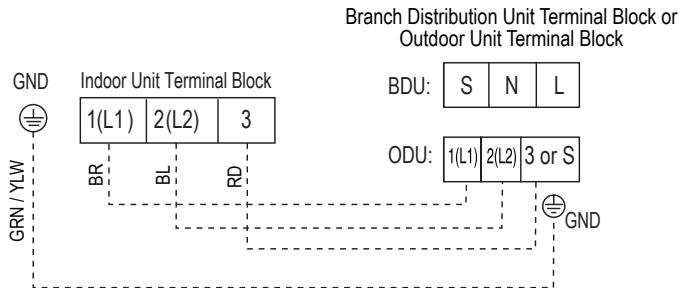
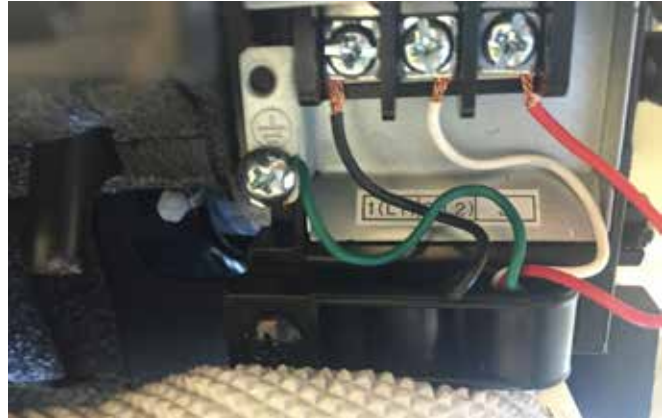

Figure 54: Typical Indoor Unit Terminal Block with Grounding Cable (Actual Appearance May Vary).



## Using a Conduit

1. Remove the rubber stopper on the indoor unit. Pass the power wiring / communications cable through the conduit, the conduit mounting plate, and to / through the control panel of the indoor unit.
2. Tighten the conduit and the conduit mounting plate together.
3. Connect the power wiring / communications cable to the indoor unit terminal block.
4. Screw the conduit mounting plate to the indoor unit.

### Note:

If the distance between the outdoor unit and indoor unit is greater than 131 feet, connect the power wiring and communications cable separately (i.e., a conduit cannot be used).

Figure 55: Using a Conduit.

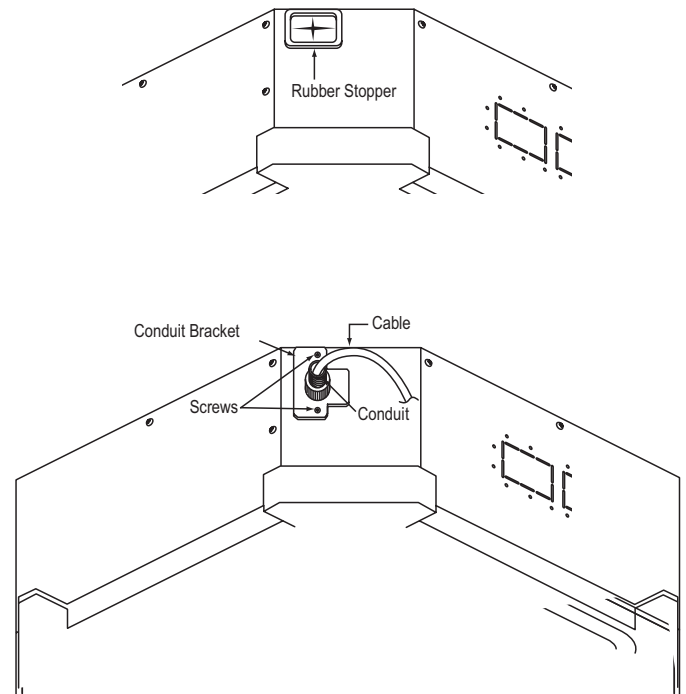

## PTVK430 Ventilation Kit

PTVK430 Ventilation Kit includes a flange for field-supplied ventilation pipe connection. Easily connects at the four-way ceiling-cassette three (3) inch fresh air knockout hole.

Figure 56: PTVK430 Ventilation Kit.

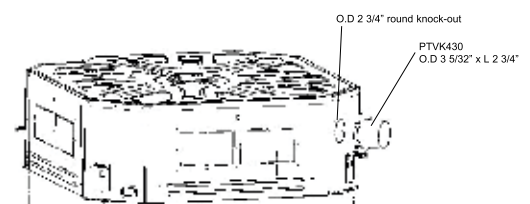

### Finalizing Indoor Unit Installation—Installing the Decoration Grille Kit

**Note:**

Decoration grille (required; sold separately) must be installed properly; cool air will leak from any gaps found between the indoor unit frame and the decoration panel, which will cause condensation to generate.

1. Remove the packaging and paper template, take out air inlet grille from the front panel (1A), and then remove the corner covers of the panel (1B).
2. Attach the panel to the indoor frame by inserting the hooks as shown (2).
3. Attach two screws on diagonal corners of each panel, but do not tighten completely (3). The screws to attach the panel to the indoor unit frame are factory-provided and can be found in the shipping box.
4. Verify the panel is aligned with the ceiling. Adjust the height by using the hanging bolts as shown (4). Attach the other two screws, and then tighten all four screws until panel is secure.
5. Attach the corner covers (5).
6. Unscrew the two screws holding the control panel cover (6).
7. Connect the one display connector (CN-DISP) and the two vane control connectors (CN-VANE1, CN-VANE2) of the front panel to the indoor unit PCB (7).
8. Reattach the control box cover (8). Attach the filter grille retainer arm (inclusion dependent on model) on the front panel as shown (9). The filter grille retainer arm is supplied in the front panel shipping package.
9. Attach the other side of the filter grille retainer arm on the filter guide of the air inlet grille (10), then install the filter and the air inlet grille on the front panel (11).

Figure 57: Installing the Decoration Grille Kit.

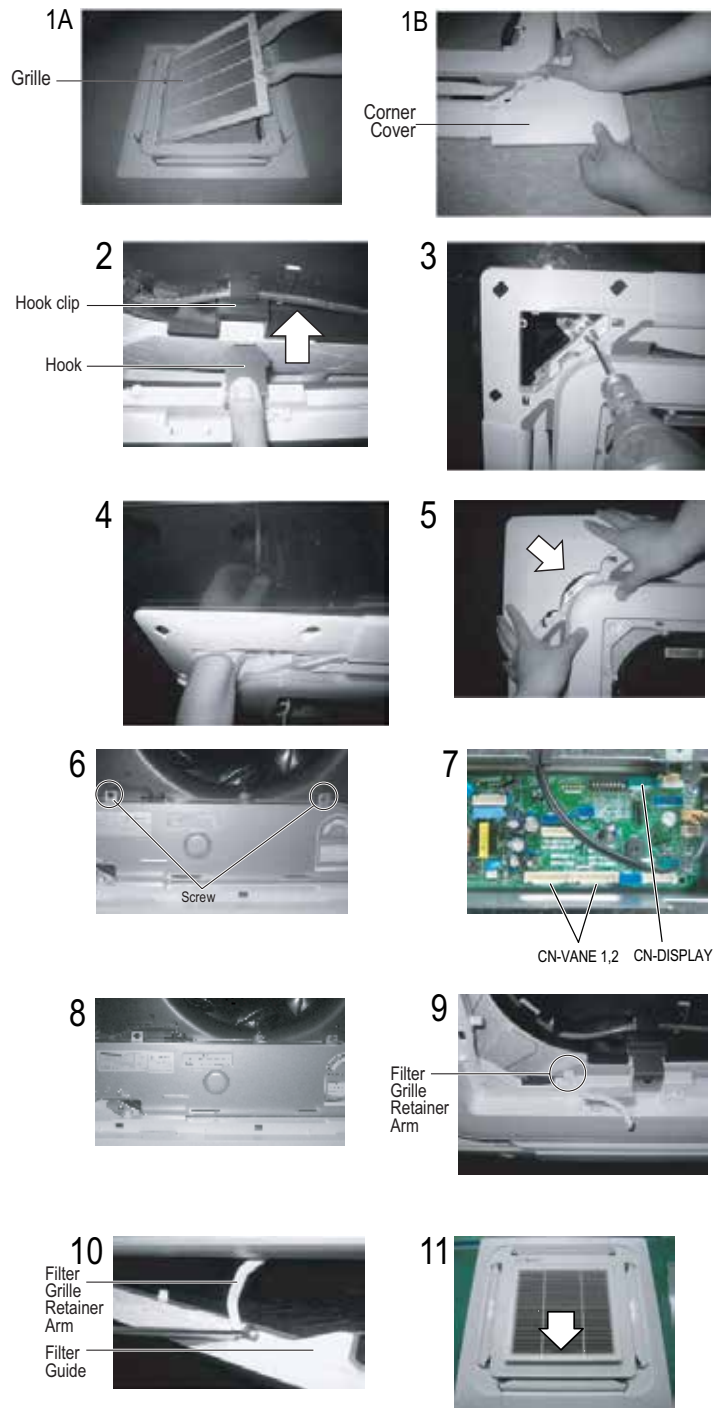
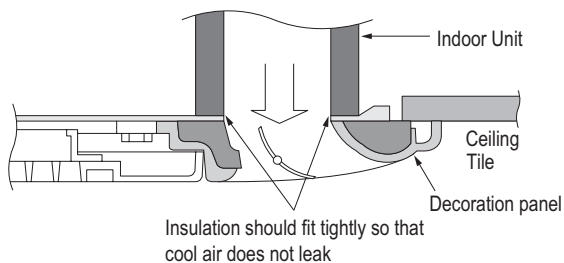

Figure 58: Ensure that no gaps are present between the indoor unit frame and the decoration grille.



### LG Monitoring View (LGMV) Diagnostic Software

LGMV software (PRCTSL1 and PRCTFE1) allows the service technician or commissioning agent to connect a computer USB port to the outdoor unit's main printed circuit board (PCB) using an accessory cable. The monitoring screen for LGMV allows the user to view the following real time data on one screen (Figure 59):

- Actual inverter compressor speed
- Target inverter compressor speed
- Actual outdoor fan speed
- Target outdoor unit fan speed
- Actual superheat
- Target superheat
- Actual subcooler circuit superheat
- Target subcooler circuit superheat
- Main EEV position
- Subcooling EEV position
- Inverter compressor current transducer value
- Outdoor air temperature
- Actual high pressure/saturation temperature
- Actual low pressure/saturation temperature
- Suction temperature
- Inverter compressor discharge temperature
- Front outdoor coil pipe temperature
- Back outdoor coil pipe temperature
- Liquid line pipe temperature
- Subcooler inlet temperature
- Subcooler outlet temperature
- Average indoor unit (IDU) pipe temperature
- Inverter compressor operation indicator light
- Liquid injection valves' operation indicator lights
- Hot gas bypass valve operation indicator light
- Four-way reversing valve operation indicator light
- Pressure graph showing actual low pressure and high pressure levels
- Error code display
- Operating mode indicator
- Target high pressure
- Target low pressure
- PCB (printed circuit board) version
- Software version
- Installer name
- Model number of IDUs

Figure 59: MV Real-time Data Screen.



- Site name
- Total number of connected IDUs
- Communication indicators
- IDU capacity
- IDU operating mode
- IDU fan speed
- IDU EEV position
- IDU room temperature
- IDU inlet pipe temperature
- IDU outlet pipe temperature
- IDU error code

#### Note:

Images on these pages are examples of LGMV screenshots. Actual images may differ depending on the version of the software and the unit installed.

Additional screens can be accessed by tabs on the main screen. Additional screens include the following:

1. Cycleview (Figure 60): Graphic of internal components including:
  - Compressors showing actual speeds
  - EEVs
  - IDUs
  - Temperature and pressure sensors
  - Four-way reversing valve
2. Graph: Full screen graph of actual high and low pressures and high and low pressure limits. A sliding bar enables user to go back in time and view data.
3. Control FTN: Enables user to turn on IDUs in 1.8°F increments.
4. Useful Tab
  - Unit Conversion: Converts metric values to imperial values.

Figure 60: MV Cycleview.

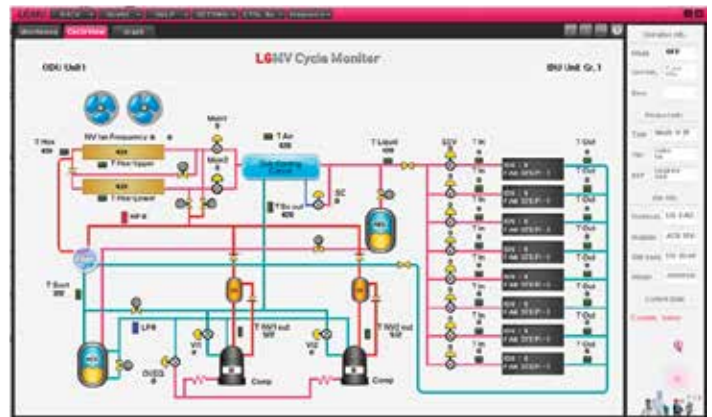

### LG Monitoring View (LGMV) Diagnostic Software and Cable - Continued

#### 5. Data

- Data Saving Start: Recording of real time data to a separate file created to be stored on the user's computer.
- Data Loading Start: Recorded data from a saved ".CSV" file can be loaded to create an LGMV session.

#### 6. Monitoring

- Electrical: The lower half of main screen is changed to show Inverter Compressor Amps, Volts, Power Hz, Inverter control board fan Hz.

#### Note:

Images on these pages are examples of LGMV screenshots. Actual images may differ depending on the version of the software and the unit installed.

## Error Codes

LGMV software helps the service technician or commissioning agent to troubleshoot system operation issues by displaying malfunction codes (Figure 62). These error codes can be seen on the main screen of the LGMV software program. For an overview of Multi F / Multi F MAX unit error codes, see Error Codes section. For detailed information on how to troubleshoot individual error codes, see the Multi F / Multi F MAX Service Manual.

The software is available in a high version with all of the listed features. The low version has all features as the high version without Target High Pressure and Target Low Pressure values shown on main screen.

In lieu of connecting to the outdoor unit, there is the option to connect to an IDU with the use of a USB to RS-485 connector kit. When connected through an IDU, the user will not be able to record data.

This software can be used to both commission new systems and troubleshoot existing systems. LGMV data can be recorded to a ".CSV" file and emailed to an LG representative to assist with diagnostic evaluations.

#### Recommended Minimum PC Configuration:

- CPU: Pentium® IV 1.6 GHz
- Main Memory: 1G
- Operating System: Windows® XP/Vista/7 32 bit (recommended), 64 bit
- Hard Disk: 600 MB when operating
- MS Office 2003, 2007 (recommended) for select reporting functions

Figure 61: MV Control Indoor Units Screen.



Figure 62: Error Code Screen.



# ELECTRICAL WIRING

## LG SIMS - Self Diagnosis Functions

# MULTI F

# MULTI F MAX

Multi F Ceiling Cassette Indoor Unit

The SIMS WLAN module and the smart phone app together provide monitoring and troubleshooting capability for LG Duct Free Systems. SIMS functions only with LG Duct Free products (Figure 63).

SIMS can display and graph operational data for the air conditioner system including the indoor unit and the outdoor unit. SIMS also displays error codes and a troubleshooting guide. A full copy of the LG SIMS Smart Inverter Monitoring System User's Manual is available on the www.lghvac.com website.

To use SIMS you must be a trained HVAC service technician familiar with variable refrigerant flow (VRF) systems in general and with LG's Duct Free System products. You should understand the inverter air conditioning operation cycle, the meaning of the data displayed by SIMS, and how to use the data to troubleshoot the system.

Figure 64 shows a typical Multi F configuration used with the SIMS module and app.

Figure 63: LG SIMS App and WLAN Module



### ⚠ WARNING

High voltages capable of causing death are used in this equipment. Outdoor unit power remains connected during this procedure. Take extreme caution not to touch electrical components or connections. Failure to observe this warning can result in death or severe injury.

### Note:

- The Duct Free System air conditioning system must run for at least 15–20 minutes before data collected by SIMS 2.0 is valid for troubleshooting.
- You must have the free SIMS app correctly installed on your smart phone before using SIMS.
- Some ODU's have an LGMV extension cable accessed by removing the side handle cover. If the ODU does not have this extension cable, access the LGMV connector by removing the top cover of the ODU.

Figure 64: SIMS WLAN Module to a Typical Multi F System.



### SIMS App Main Info Screen

The main screen (Figure 65) is the first screen displayed after wireless connection is established. Tap the Main Info tab to display current readings regarding your indoor and outdoor unit(s). The Operational Info area of the screen will show active functions or modes by illuminating the light to the right of the function.

Additional Help information can be accessed by tapping the Help Menu buttons at the bottom of this screen.

Figure 65: SIMS App Main Info Screen

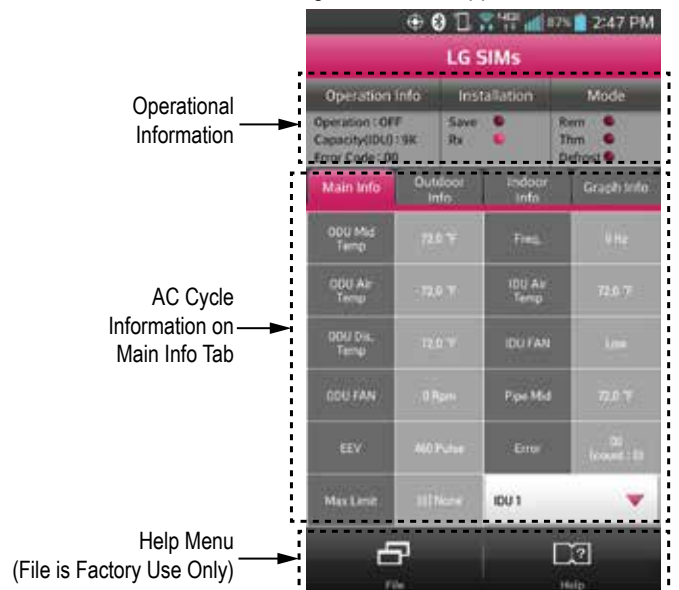

### SIMS App Screens

#### Outdoor Info/ Component Screen

Displays the following information:

- Frequency
- FAN1 RPM
- FAN2 RPM
- DC Link
- Current
- Voltage
- EEV Mode
- Restart Timer
- Comp Mode
- EEV



#### Outdoor Info/ Temperature Screen

Displays the following information:

- Inv TD
- Suction
- Discharge
- Cond Mid
- Cond Out
- Heatsink
- Air Temp



#### Indoor Info Tab

Displays the following information:

- Frequency
- Operation
- THM Mode
- REM Mode
- FAN
- EEV
- Air Temp
- Pipe-in
- Pipe-mid
- Pipe-out

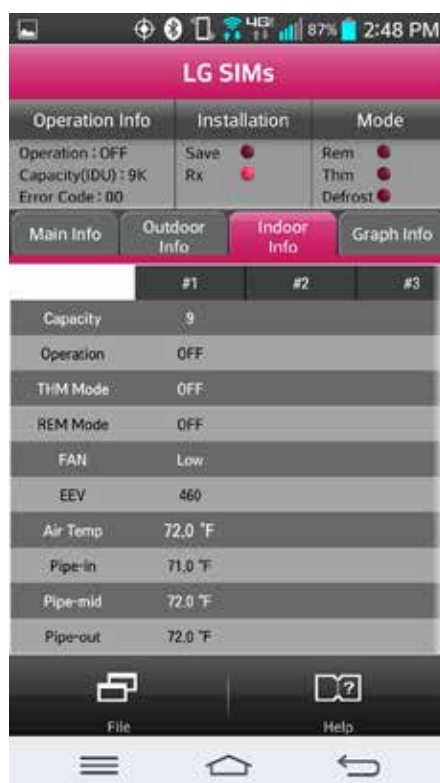

#### Graph Info Tab

This tab has three sub sections:

- IDU - Indoor Unit Temperature graph. Displays IDU information in graph format. Information displayed is for the IDU # selected on the Main screen.
- ODU - Outdoor Unit Temperature and Frequency graph. Displays ODU information in graph format.
- ODU Electric - Outdoor Unit Electric data graph is displayed.

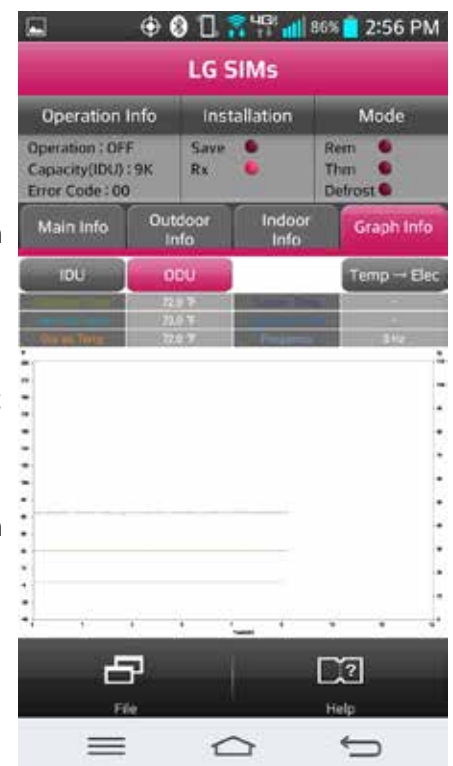

### Controller Options

Ceiling-concealed indoor units include a wireless handheld controller (AKB73757604)<sup>1</sup>, but optional LG-supplied wired controllers are available.

#### Wireless Handheld Controller

Figure 66: AKB73757604 Wireless Handheld Controller.

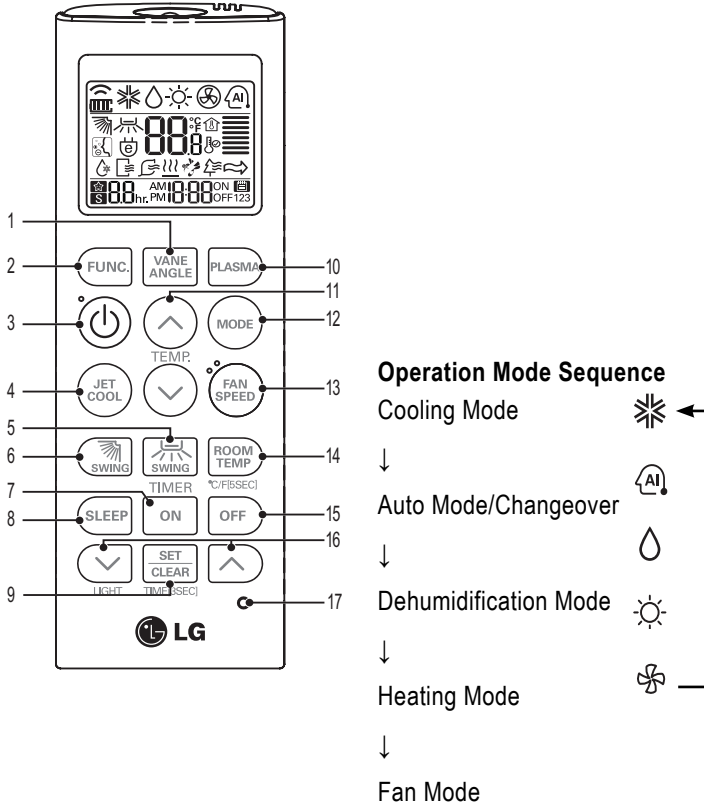
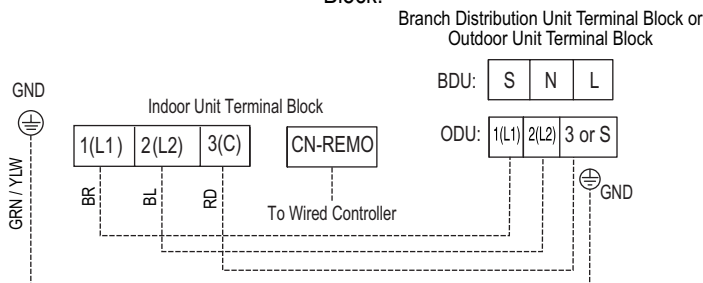

Table 35: AKB73757604<sup>1</sup> Wireless Handheld Controller Functions.<sup>2</sup>

Button Label	Description
1	Vane Angle Button: Sets the angle to each vane.
2	Function Setting Button: Sets or clears auto clean, smart clean, electric heater, or individual vane angle control functions.
3	On / Off Button: Turns the power on/off.
4	Jet Cool: Sets the unit to super high fan speed when in cooling mode.
5	Left / Right Air Flow Button (optional): Sets the desired left / right (horizontal) air flow direction.
6	Up / Down Air flow Button: Stops or starts louver movement, and sets the desired air flow direction to up or down.
7	On Time Button: Sets the time when the operation begins.
8	Sleep Timer Button: Sets the sleep mode operation.
9	Set / Clear Button: Sets or cancels the timer, also sets the current time.
10	Plasma Button: Starts or stops plasma-purification functions.
11	Room Temperature Setting Button: Raises or lowers temperature setpoint in cooling and heating operation.
12	Operation mode selection button: Selects the operation mode.
13	Indoor Fan Speed Button: Changes the fan speed to one of four choices: low, medium, high, and chaos.
14	Room Temperature Check Button: Displays / checks the room temperature.
15	Off Timer button: Sets the time when the operation ends.
16	Time Setting (Up / Down) / Light Button: Sets the timer and adjusts the brightness of the LED.
17	Reset Button: Resets the remote controller.

### Wired Controller Connections

Figure 67: Wired Controller Connection on the Indoor Unit Terminal Block.



<sup>1</sup>Wireless Handheld Controller for the four-way ceiling cassette indoor units is also referenced by Model No. PQWRHQ0FDB.

<sup>2</sup>Depending on the indoor unit model, some functions may not be supported or displayed.

## Wall-Mounted Controller Placement

Since the room temperature sensor is inside the remote controller, the remote controller should be installed in a place away from direct sunlight, high humidity and direct supply of hot or cold air to maintain proper space temperature. Install the remote controller about five (5) feet above the floor in an area with good air circulation and an average temperature.

⊘ Do not install the remote controller where it can be affected by the following:

- Drafts or dead spots behind doors and in corners
- Hot or cold air from ducts
- Radiant heat from the sun or appliances
- Concealed pipes and chimneys
- An area where temperatures are uncontrolled, such as an outside wall

This remote controller is equipped with a seven segment LED display. For proper display of the remote controller LEDs, the remote controller should be installed properly as shown below. The standard height is four (4) to five (5) feet from floor level.

1. Pull communications cable between the zone controller handy box (if used) and the indoor unit. The wall-mounted zone controller comes with a thirty-three (33) foot length of cable.
2. Store a minimal amount of cable in the handy box. Any additional cable should be coiled and stored near the indoor unit control panel.
3. If additional cable length is needed, order a thirty-three (33) foot LG Wired Remote Group Control Extension cable (Model No. PZCWRC1).
4. If the cable between the zone controller and the indoor unit is too long, do not cut the cable and shorten. Coil any spare communications cable, tie-wrap it, and leave it next to the indoor unit location.

Figure 68: Proper Location for the Wired Controller.

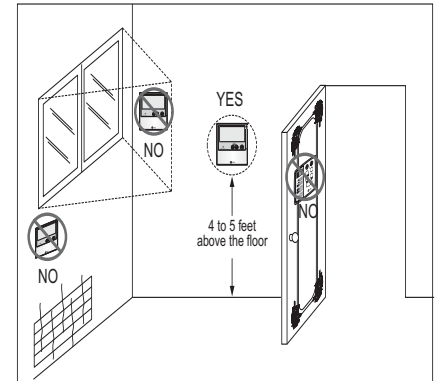

## Hanging the Wired Controller

1. The controller wiring / cable can be installed in one of three directions: top, back, or on the right side. If top or right side installation is desired, remove cable guide grooves on the controller, and then position wiring / cable on applicable side.
2. Choose and mark the area of installation, and then screw the wall plate into place (using the provided parts). Install the controller wall plate to fit the electrical box if one is present. Ensure that no gaps exist between the wall plate and the wall itself.
3. Arrange wiring / cables so it does not interfere with the controller circuitry. Position the wired controller on the wall plate. Snap into place by pressing the bottom part of the wired controller onto the wall plate. Make sure that no gaps exist between the wired controller and the wall plate on all sides.
4. To remove wired controller from the wall plate, insert a screwdriver into the two holes at the bottom. Twist screwdriver to release controller. ⊘ Do not damage the controller components when removing.

Figure 69: Removing the Cable Guide Grooves (Plate Appearance will Differ Depending on Controller Type).

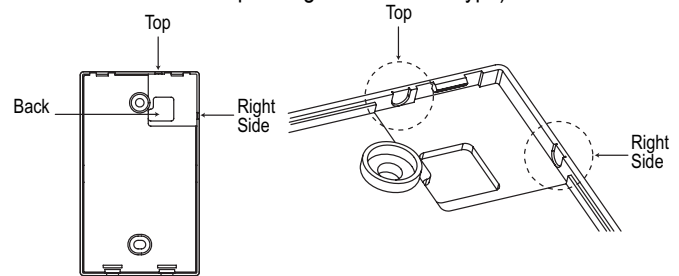

Figure 70: Attaching the Wall Plate (Plate Appearance will Differ Depending on Controller Type).

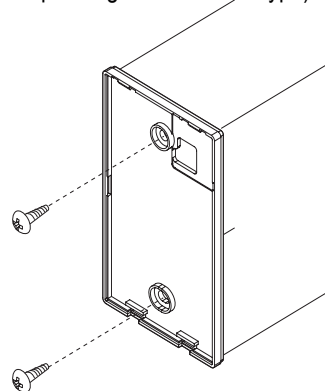
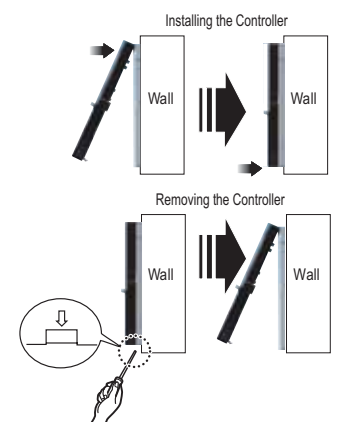

Figure 71: Installing / Removing the Controller.



### Hanging the Wired Controller, continued.

- Connect indoor unit and wired controller using included connection cable.
- Use an LG-manufactured extension cable (sold separately) if the distance between wired remote controller and the indoor unit is >32.8 feet.

Figure 72: Indoor Unit to Wired Controller Connection (Controller Appearance May Vary Depending on Model Chosen).

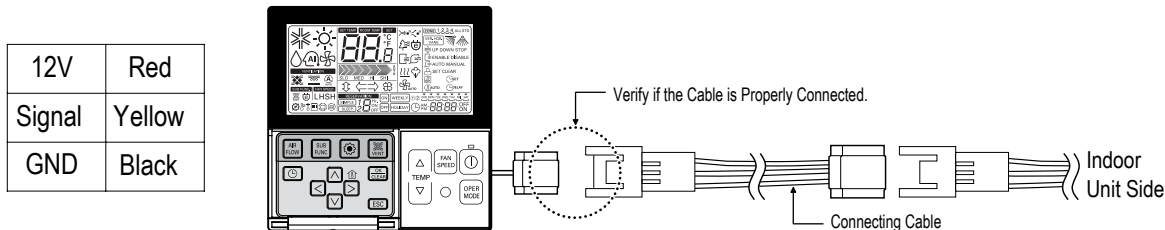

### Note:

- Do not bury the wired controller into the wall; burying it may damage the temperature sensor.
- Do not extend the connecting cable >164 feet; overly long cable lengths can cause communication errors.
- When installing the LG-manufactured extension cable, make sure to connect the proper ends together.

## Assigning the Thermistor for Temperature Detection

Each indoor unit includes a return air thermistor assigned to sense the temperature. If a wired controller is installed, there is a choice of sensing temperature with either the indoor unit return air thermistor or the thermistor in the wired controller. It is also an option to set both thermistors to sense temperature so that indoor unit bases its operation on the first thermistor to reach the designated temperature differential.

An optional Remote Temperature Sensor can be used in lieu of the return air thermistor—either alone or in conjunction with a wired controller thermistor as previously described.

### Troubleshooting Using Error Codes

Refer to Table 36 for information on the error codes that are generated from the indoor and outdoor units. These codes are the most common that will manifest through these units. Your particular model duct free system might generate additional codes not listed here. Please contact LG Support if you see these types of errors and a simple power down and boot up has not corrected the issue. You should not attempt to fix the system yourself.

#### Error Codes

- Error codes indicate different types of unit failures, assists in self-diagnosis and to track the frequency of occurrence.
- Error codes are shown on the LEDs of indoor units, wired remote controller, the outdoor unit control board, and LG Monitoring View (LGMV) Diagnostic Software.
- If two or more errors occur simultaneously, the lower error code number is displayed first.
- After error is resolved, the error code does not display.

#### Decoding the Error Display

The first and second number on the LED indicates error number.  
Example: 21 = LED1 2x blink, LED2 1x blink.

#### Error Code Nomenclature Definitions

- MICOM: Non-volatile memory chip where unit setup information is stored.
- EPROM: Non-volatile memory chip where device identification, size, and factory defined default component operating parameters are stored.

Figure 73: Example of Ceiling Cassette IDU LEDs (appearance may differ depending on model).

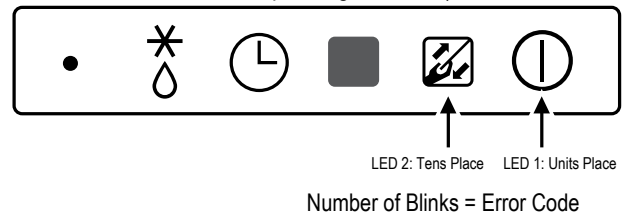

Table 36: Multi Zone Ceiling Cassette Indoor Unit Error Codes.

Error Code	Description	No. of Times Indoor Unit LEDs Blink	
		LED1 (Plasma LED)	LED2 (Power LED)
1	Indoor unit room temperature sensor error	1X	-
2	Indoor unit inlet pipe sensor error	2X	-
4	Float switch error (optional)	4X	-
5	Communication error between indoor unit and outdoor units	-	5X
6	Indoor unit outlet pipe sensor error	6X	-
9	Indoor unit EPROM error	9X	-
10	Indoor unit BLDC motor fan lock	-	1X
12	Indoor unit middle pipe sensor error	2X	1X

### Troubleshooting Using Error Codes - Continued

Table 37: Multi Zone Outdoor Unit Error Codes.

Error Code	Description	No. of Times Indoor Unit LEDs Blink	
		LED1 (Plasma LED)	LED2 (Power LED)
21	DC Peak (IPM Fault); Compressor DC voltage was too high	2X	1X
22	Current Transformer2 (CT2) error; Alternating current (AC) input too high	2X	2X
23	DC Link Low Volt	2X	3X
25	AC Low/High Volt	2X	5X
26	DC Comp Position Error (not providing rotation), Locking	2X	6X
27	PSC Fault; Current to inverter compressor between AC and DC converter circuit too high	2X	7X
28	Inverter compressor DC voltage is too high	2X	8X
29	Inverter compressor amperage is too high	2X	9X
31	Current-to-current transformer (CT) thermistor is too low	3X	1X
32	Inverter Compressor Discharge Pipe (D-Pipe) Overheat	3X	2X
40	CT Sensor Error; Thermistor is disconnected or shorted out	4X	-
41	D-Pipe Sensor INV is disconnected or shorted out	4X	1X
44	Outdoor Air Sensor is disconnected or shorted out	4X	4X
45	Middle thermistor of outdoor unit condenser coil is disconnected or shorted out	4X	5X
46	Outdoor unit suction line thermistor is disconnected or shorted out	4X	6X
48	Outdoor unit coil outlet (liquid line) thermistor is disconnected or shorted out	4X	8X
53	Communication failure from outdoor unit to indoor unit	5X	3X
60	Outdoor unit printed circuit board (PCB) EPROM check sum error	6X	-
61	Outdoor unit condenser coil temperature is too high	6X	1X
62	Outdoor unit inverter compressor PCB heat sink temperature is too high	6X	2X
63	Condenser coil pipe thermistor temperature is too low	6X	3X
65	Heat sink thermistor has disconnected or has shorted out	6X	5X
67	Outdoor brushless direct current (BLDC) fan motor lock error	6X	7X

Refer to Service Manuals posted on [www.lghvac.com](http://www.lghvac.com) for a full description of all error codes and workarounds.

## Cautions for Refrigerant Leaks

ASHRAE Standards 15 and 34 offer guidelines that address refrigerant safety and the maximum allowable concentration of refrigerant in an occupied space. Refrigerant will dissipate into the atmosphere, but a certain volume of air is required for this to occur safely. For R410A refrigerant, the maximum allowable concentration is 0.026 lbs./ft<sup>3</sup> per 1,000 ft<sup>3</sup> of air in an occupied space. Buildings with twenty-four (24) hour occupancy allow half of that concentration.<sup>1</sup>

ASHRAE Standards 15 and 34 assume that if a system develops a leak, its entire refrigerant charge will dump into the area where the leak occurs. To meet ASHRAE Standards 15 and 34, calculate the refrigerant concentration that may occur in the smallest room volume on the system, and compare the results to the maximum allowable concentration number (see below for information on how to calculate the refrigerant concentration).<sup>1</sup> Also consult state and local codes in regards to refrigerant safety.

### **⚠ WARNING**

Verify the maximum refrigerant concentration level in the space where the indoor unit will be mounted meets the concentration limit for the application. If the refrigerant leaks and safety limits are exceeded, it could result in personal injuries or death from oxygen depletion.

### **Note:**

Take appropriate actions at the end of HVAC equipment life to recover, recycle, reclaim or destroy R410A refrigerant according to applicable US EPA rules.

To calculate the potential refrigerant concentration level (RCL):

1. Measure the occupied space dimensions (in feet).
2. Calculate the cubic foot volume of air in the smallest occupied space. (To obtain a detailed overview of the RCL, perform the same calculations to the second smallest zone, the third smallest zone until the RCL is obtained for all zones. Also, pay special attention to areas such as basements, etc., where refrigerant cannot dissipate easily.)
3. Divide the refrigerant charge of the Multi Zone system serving the area in pounds by the results of step 1.
4. If the calculation indicates that the potential refrigerant concentration level is higher than the allowed RCL, increase the cubic volume of the smallest occupied space or modify the piping system design.
5. The allowable RCL limit for most applications must be equal to or less than 0.026 lbs./ft<sup>3</sup>. In special occupied spaces, however, such as hospitals and nursing homes where occupants may have limited mobility, the allowable RCL limit is cut in half. See ASHRAE Standard 34-2007 and local codes for detailed information.<sup>1</sup>

### Refrigerant Concentration Limit (RCL) Calculations

To calculate total refrigerant amount per system:

<b>Amount of Factory-Charged Refrigerant per Outdoor Unit</b>	<b>+</b>	<b>Amount of Additional Re- frigerant Trim Charge</b>	<b>=</b>	<b>Total System Refrigerant Charge</b>
---	----------	---	----------	--

$$\text{RCL (lbs./ft}^3\text{)} = \frac{\text{Total System Refrigerant Charge (lbs.)}}{\text{Volume of Smallest Occupied Space (ft}^3\text{)}}$$

<sup>1</sup>American Society of Heating, Refrigeration and Air Conditioning Engineers, Inc. (ASHRAE). Atlanta, GA. ASHRAE, Inc. Information about ASHRAE Standard 15-2010 / 34-2010 and addenda current as of the date of this publication.



## Major Component Rough-In

Description	Check
All Multi F / Multi F MAX outdoor units were connected properly per local code and the product installation procedures.	
All literature and bagged accessories have been removed from the fan discharge.	
Indoor units and branch distribution unit(s) (Multi F MAX only) are installed, properly supported, and located indoors in a non-corrosive environment.	
Multi F / Multi F MAX gravity condensate drain line was connected and routed where it properly drains away or, if installed in a mechanical room, was connected and properly routed to a drain terminal.	

## Piping and Insulation

Description	Check
Copper	
Over 5/8 inches—Rigid ACR only.	
5/8 inches and under—Can use soft ACR.	
15% silver brazing material only.	
All refrigerant pipes and valves were insulated separately. Insulation butts up against the walls of the indoor units. No gaps or cracks. Insulation was not compressed at clamps and hangers.	
LG Y-branches were used per manufacturer's recommendations.	
(Optional) Full port ball valves for all indoor units. (Schrader between the valve body and the indoor units.)	
Condensate piping installed on indoor units—material used is acceptable under local code. Insulated as necessary to prevent condensation.	

## Brazing Practices

Description	Check
Medical grade (there are 4 available) dry nitrogen for purging during brazing was used (constant 3 psi while brazing).	

## Installation

(For more information on any procedure, refer to the detail provided in the Indoor Unit Installation Manuals.)

## Refrigerant Piping

Description	Check
Have in possession a copy of the "As-Designed" LATS Multi F piping tree diagram. BEFORE ANY FIELD PIPE SIZE OR LENGTH CHANGES ARE MADE, PROPOSED CHANGES MUST BE FORWARDED TO THE DESIGN ENGINEER SO THAT THEY CAN INPUT THE CHANGES INTO LATS and RE-ISSUE A NEW LATS PIPING TREE DIAGRAM. Installer must receive change authorization from the design engineer, because any change made requires the review of the entire tree diagram and verification that the change did not impact the size of piping segments in other parts of the system.	
All pipe materials were properly stored, capped, and clean. All burrs were removed after cutting and pipe ends were reamed before brazing.	
During refrigerant pipe installation, for each segment of pipe, a record was made of the pipe length (including expansion loops, offsets, double-back sections), and sizes, as well as the quantity and type of elbows used.	
All long runs of straight pipe were provided with expansion loops.	
Ensure Y-branches are installed with no more than $\pm 5^\circ$ of horizontal.	
Ensure Y-branches are installed with no more than $\pm 3^\circ$ of vertical.	
A torque wrench and backup wrench were used to tighten all flare connections.	
The back side of all flares were lubricated with a small drop of PVE refrigeration oil before tightening flare fittings.	
Ensure all field made flares are $45^\circ$ . Use factory-supplied flare nuts only.	
Pipe segments were properly supported and all wall penetrations were sleeved.	
Pipe insulation was not compressed at any point.	
Y-branches were properly supported per details provided in the installation manual.	
Ensure Y-branches are installed in the correct direction. Flow is always from the single end to the double end.	
No oil traps, solenoid valves, sight glasses, filter driers, or any other unauthorized refrigerant specialties were present.	
(Optional) R410A rated full port ball valves were used at all indoor units and wherever appropriate in the refrigerant piping network.	
Best practice including a minimum of 20" of straight pipe was installed between each elbow.	



**Condensate Pump / Drain Installation**

Description	Check
Indoor unit condensate drain pipes were installed correctly.	
All condensate vertical risers are equal to or less than 27-1/2" from the bottom of the indoor unit.	
Indoor units with condensate pumps were level. Units with gravity drains were level or slightly canted toward the drain connection and are supported properly.	
Pumped condensate drain lines were properly connected (do not have traps, and connect to the top surface of the main drain line).	

**Power Wire and Communications Cables**

Description	Check
Power wiring was connected to a single phase 208-230V source.	
Ground wire was installed and properly terminated at the unit.	
The power supplied was clean with voltage fluctuations within specifications. ( $\pm 10\%$ of nameplate).	
Power wiring to the Multi F / Multi F MAX outdoor unit was installed per all local electrical code requirements.	
Power wiring to the indoor units and branch distribution unit(s) (Multi F MAX only) was installed per all local electrical code requirements.	
LG-supplied cable was used between each indoor unit and its zone controller. No cables were spliced and no wire caps are present.	
Communication type RS-485-BUS type.	
Communications / power were a minimum of 18-AWG, four (4) conductor, stranded, shielded or unshielded, with insulation material per local code. If shielded, must be ground to outdoor unit only. Cable segment shields were tied together.	
Used appropriate crimping tool to attach ring or spade terminals at all power wiring and control cable terminations.	
Power and control wires were run in the same conduit (ODU to IDU only) as provided in the product installation manual. Power to ODU and power/communications to IDU cannot be run in the same conduit and must be separated per manufacturer's guidelines.	



## Major Component Rough-In

## Piping and Insulation

## Brazing Practices



**Installation—Refrigerant Piping**

**Installation—Branch Distribution Unit (Multi F MAX Systems Only)**

**Installation—Condensate Pump / Drain Installation**

**Installation—Power Wire and Communications Cables**



LG Multi F outdoor units ship from the factory with a charge of R410A refrigerant. A trim charge may need to be added to take into account additional piping length.

To determine the additional refrigerant that is needed, apply the formula below, and record the results. If the total additional refrigerant charge value is a negative number, then an additional trim charge does not need to be added to the system.

**Multi F Outdoor Unit Factory Charge**

Outdoor Unit	Factory Charge lbs. of R410A
LMU18CHV	3.96
LMU24CHV	3.96
LMU30CHV	6.18
LMU36CHV	6.18

**Multi F Outdoor Unit Additional Refrigerant Charge Formula**

$$\begin{aligned} \text{Additional charge (lbs.)} &= (\text{Installed Length of Branch [A]} - \text{Chargeless Pipe Length [L]}) \times a \\ &+ (\text{Installed Length of Branch [B]} - \text{Chargeless Pipe Length [L]}) \times a \\ &+ (\text{Installed Length of Branch [C]} - \text{Chargeless Pipe Length [L]}) \times a \\ &+ (\text{Installed Length of Branch [D]} - \text{Chargeless Pipe Length [L]}) \times a \\ &- \text{CF (Correction Factor)} \times 5.29 \end{aligned}$$

**Note:**

- Number of installed length of branches depends on the specifications of the outdoor unit model.
- CF = Maximum number of connectable indoor units – Total number of connected indoor units.

**Multi F Outdoor Unit Piping Specifications**

Multi F Outdoor Unit Model	Min. to Max. Piping Length for One Branch (ft.)	Max. Total System Piping Length (ft.)	Chargeless Pipe Length per Branch (L) (ft.)	Additional Charge Needed (a) (oz./ft.)
LMU18CHV	10 to 82	164	24.6	0.22
LMU24CHV	10 to 82	246.1	24.6	0.22
LMU30CHV	10 to 82	246.1	24.6	0.22
LMU36CHV	10 to 82	246.1	24.6	0.22

**Multi F Refrigerant Charge Calculations**

$$\begin{aligned} &(\text{_____ [A]} - 24.6) \times 0.22 && (\text{_____}) \\ &+ (\text{_____ [B]} - 24.6) \times 0.22 && + (\text{_____}) \\ &+ (\text{_____ [C]} - 24.6) \times 0.22 && + (\text{_____}) \\ &+ (\text{_____ [D]} - 24.6) \times 0.22 && + (\text{_____}) \\ &- \text{_____ CF} \times 5.29 && - (\text{_____}) \\ &= \text{_____ Additional Charge (lbs.)} \end{aligned}$$

# MULTI F MULTI F MAX

# MULTI F MAX REFRIGERANT CHARGE WORKSHEET



LG Multi F MAX outdoor units ship from the factory with a charge of R410A refrigerant. A trim charge may need to be added to take into account additional piping length.

To determine the additional refrigerant that is needed, apply the formula below, and record the results. If the total additional refrigerant charge value is a negative number, then an additional trim charge does not need to be added to the system.

### Multi F MAX Outdoor Unit Factory Charge

Outdoor Unit	Factory Charge lbs. of R410A
LMU480HV	9.7
LMU540HV	9.7
LMU600HV	12.3

$$\begin{aligned} \text{Additional charge (lbs.)} &= (\text{Total Main Piping Length [A]} - \text{Chargeless Pipe Length of Main Pipe [L]}) \times a \\ &+ (\text{Installed Length of Branch [B1]} - \text{Chargeless Pipe Length [B]}) \times b \\ &+ (\text{Installed Length of Branch [B2]} - \text{Chargeless Pipe Length [B]}) \times b \\ &+ (\text{Installed Length of Branch [B3]} - \text{Chargeless Pipe Length [B]}) \times b \dots \\ &- \text{CF (Correction Factor)} \times 3.53 \end{aligned}$$

### Note:

- Number of installed length of branches depends on system specifications.
- CF = Maximum number of connectible indoor units – Total number of connected indoor units

### Multi F MAX Outdoor Unit Piping Specifications

Outdoor Unit Model	Main Piping Length		Branch Piping Length	
	Chargeless Pipe Length of Main Pipe (L) (ft.)	Additional Charge Needed (a) (oz./ft.)	Chargeless Pipe Length per Branch Pipe (B) (ft.)	Additional Charge Needed (b) (oz./ft.)
LMU480HV	16.4	0.54	16.4	0.22
LMU540HV	16.4	0.54	16.4	0.22
LMU600HV	16.4	0.54	16.4	0.22

### Multi F MAX Refrigerant Charge Calculations

$$\begin{aligned} &(\text{_____ [A]} - 16.4) \times 0.54 && (\text{_____}) \\ &+ (\text{_____ [B1]} - 16.4) \times 0.22 && + (\text{_____}) \\ &+ (\text{_____ [B2]} - 16.4) \times 0.22 && + (\text{_____}) \\ &+ (\text{_____ [B3]} - 16.4) \times 0.22 && + (\text{_____}) \\ &+ (\text{_____ [B4]} - 16.4) \times 0.22 && + (\text{_____}) \\ &+ (\text{_____ [B5]} - 16.4) \times 0.22 && + (\text{_____}) \\ &+ (\text{_____ [B6]} - 16.4) \times 0.22 && + (\text{_____}) \\ &+ (\text{_____ [B7]} - 16.4) \times 0.22 && + (\text{_____}) \\ &+ (\text{_____ [B8]} - 16.4) \times 0.22 && + (\text{_____}) \\ &- \text{_____ CF} \times 3.53 && - (\text{_____}) \\ &&& = \text{_____ Additional Charge (lbs.)} \end{aligned}$$

### **Who to call for assistance**

Freight Damage and Unit Replacements

Missing Parts

Freight Damage and Unit Replacements

Received Wrong Indoor Unit Model

Installation, Startup, and Commissioning Technical Assistance

Your LG Manufacturer Representative

Your LG Manufacturer Representative

Your LG Manufacturer Representative

Your LG Manufacturer Representative

1-888-865-3026

**For warranty information, visit [www.lghvac.com](http://www.lghvac.com).**

*Inverter*



LG Electronics, U.S.A., Inc.  
Commercial Air Conditioning Division  
4300 North Point Parkway  
Alpharetta, Georgia 30022  
[www.lg-vrf.com](http://www.lg-vrf.com)

LG Customer Information Center, Commercial Products  
1-888-865-3026 USA  
Follow the prompts for commercial A/C products and parts.

IM\_Multi\_F\_CeilingCassette\_7\_16  
Supersedes: M\_Multi\_F\_CeilingCassette\_9\_15



**LG**

Life's Good

ENGLISH

FRANÇAIS

ESPAÑOL

# INSTALLATION MANUAL AIR CONDITIONER

- Please read this installation manual completely before installing the product.
- Installation work must be performed in accordance with the national wiring standards by authorized personnel only.
- Please retain this installation manual for future reference after reading it thoroughly.

TYPE : Multi Type

<http://www.lghvac.com>  
[www.lg.com](http://www.lg.com)



P/NO : MFL68280101

# FLEX MULTI SPLIT INSTALLATION INSTRUCTIONS

## IMPORTANT!

**Please read this instruction sheet completely before installing the product.**

This air conditioning system meets strict safety and operating standards. As the installer or service person, it is an important part of your job to install or service the system so it operates safely and efficiently.



### WARNING

- Installation or repairs made by unqualified persons can result in hazards to you and others. Installation MUST comply with local building codes or, in the absence of local codes, with the National Electrical Code NFPA 70/ANSI C1-1993 or current edition and Canadian Electrical Code Part1 CSA C.22.1.
- The information contained in this manual is intended for use by a qualified service technician familiar with safety procedures and equipped with the proper tools and test instruments.
- Failure to carefully read and follow all instructions in this manual can result in equipment malfunction, property damage, personal injury and/or death.

**CAUTION:** Improper installation, adjustment, alteration, service or maintenance can void the warranty. The weight of the condensing unit requires caution and proper handling procedures when lifting or moving to avoid personal injury. Use care to avoid contact with sharp or pointed edges.

### Safety Precautions

- Always wear safety glasses and work gloves when installing equipment.
- Never assume electrical power is disconnected. Check with meter and equipment.
- Keep hands out of fan areas when power is connected to equipment.
- R410A causes frostbite burns.
- R410A is toxic when burned.

**NOTE TO INSTALLING DEALER :** The Owners Instructions and Warranty are to be given to the owner or prominently displayed near the indoor Air Handler Unit.



### Special warnings

#### When wiring:

**Electrical shock can cause severe personal injury or death. Only a qualified, experienced electrician should attempt to wire this system.**

- Do not supply power to the unit until all wiring and tubing are completed or reconnected and checked.
- Highly dangerous electrical voltages are used in this system. Carefully refer to the wiring diagram and these instructions when wiring. Improper connections and inadequate grounding can cause accidental injury or death.
- Ground the unit following local electrical codes.
- Connect all wiring tightly. Loose wiring may cause overheating at connection points and a possible fire hazard.

#### When transporting:

Be careful when picking up and moving the indoor and outdoor units. Get a partner to help, and bend your knees when lifting to reduce strain on your back. Sharp edges or thin aluminum fins on the air conditioner can cut your fingers.

#### When installing...

**... in a wall:** Make sure the wall is strong enough to hold the unit's weight.

It may be necessary to construct a strong wood or metal frame to provide added support.

**... in a room:** Properly insulate any tubing run inside a room to prevent "sweating" that can cause dripping and water damage to wall and floors.

**... in moist or uneven locations:** Use a raised concrete pad or concrete blocks provide a solid, level foundation for the outdoor unit. This prevents water damage and abnormal vibration.

**... in an area with high winds:** Securely anchor the outdoor unit down with bolts and a metal frame. Provide a suitable air baffle.

**... in a snowy area(for Heat Pump Model):** Install the outdoor unit on a raised platform that is higher than drifting snow. Provide snow vents.

#### When connecting refrigerant tubing

- Keep all tubing runs as short as possible.
- Use the flare method for connecting tubing.
- Check carefully for leaks before starting the test run.

#### When servicing

- Turn the power OFF at the main power box(mains) before opening the unit to check or repair electrical parts and wiring.
- Keep your fingers and clothing away from any moving parts.
- Clean up the site after you finish, remembering to check that no metal scraps or bits of wiring have been left inside the unit being serviced.

# TABLE OF CONTENTS

## Installation Requirements











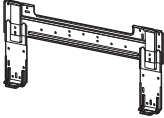
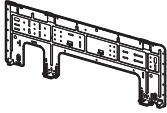
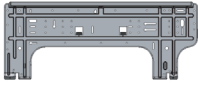
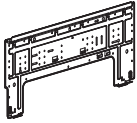



<b>Installation Parts Provided</b> .....	4
<b>Safety Precautions</b> .....	5
<b>Installation of Indoor, Outdoor Unit</b> .....	8
Select the best location .....	8
Seaside Applications and Installation .....	10
Seasonal Wind And Cautions In Winter.....	11
Piping length and elevation .....	12
<b>Installation</b> .....	14
Connecting the piping.....	14
How To Fix.....	18
Wiring Connection .....	19
Conduit connection.....	19
Ceiling dimension and hanging bolt location .....	20
How to Fix .....	21
Wiring Connection .....	21
Conduit connection.....	21
Installation of Wired Remote Controller(Optional).....	22
Installation of Decorative Panel.....	24
Drain Piping.....	26
<b>Flaring Work and Connection of Piping</b> .....	29
Flaring work.....	29
Connection of piping - Outdoor .....	30
Installation .....	33
Installation of The Main Unit.....	34
<b>Connecting the Cable between Indoor Unit, Distributor Unit and Outdoor Unit</b> .....	35
Connect the cable to the Indoor unit .....	35
Connect the cable to the Distributor unit .....	36
Connect the cable to the Outdoor unit.....	37
Connection method of the connecting cable(Example).....	39
<b>Checking the Drainage, Insulating the Pipe and Special Piping Applications</b> .....	40
Checking the drainage .....	40
Insulating the Pipe and Special Piping Applications.....	40
<b>Air Purging and Evacuation</b> .....	41
Leak Checking.....	41
Evacuation.....	42
<b>Charging</b> .....	43
<b>Installation PI485</b> .....	45
<b>Test Running</b> .....	46
<b>Function</b> .....	47
Dip S/W Setting.....	47
Forced Cooling Operation .....	48
Wiring Error Check.....	49
Saving Power Consumption .....	49
Night Quiet Mode .....	50
Mode Lock.....	51
Pcb Display(18/24k Model Only) .....	52
<b>Combination indoor units</b> .....	53

## Required Tools







- Level gauge
- Screw driver
- Electric drill
- Hole core drill (ø50mm)
  
- Flaring tool set
- Specified torque wrenches  
1.8kg.m, 4.2kg.m, 5.5kg.m, 6.6kg.m  
(different depending on model No.)
- Adjustable wrench
  
- A glass of water
- Screw driver
  
- Hexagonal wrench(4mm)
- Refrigerant Gas Leak Detector
- Vacuum pump
- Gauge manifold
  
- Owner's manual
- Thermometer
- Remote Control Holder

# Installation Parts Provided

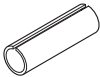







## [Wall mounted / ART COOL Mirror]

Type 1	Type 2	Type 3		Type 4	
Installation plate	Installation plate	Installation plate		Installation plate	
					
Type "B" screw	Type "B" screw	Type "B" screw	Type "C" screw	Type "B" screw	Type "C" screw
					
Type "A" screw	Type "A" screw	Type "A" screw		Type "A" screw	
					
Remote control holder	Remote control holder	Remote control holder		Remote control holder	
					

## [Ceiling Concealed Duct Type]

Name	Clamp metal	Insulation for fitting	Screws for duct flanges	Clamp	Conduit Bracket
Quantity	1 EA	1 set	1 set	8 EA	1 EA
Shape		 for gas pipe  for liquid pipe			 Conduit Bracket  Screw(M4) 2EA

## [Ceiling Cassette Type]

Name	Drain hose	Clamp metal	Washer for hanging basket	Clamp	Conduit Bracket	Insulation for fitting	Remote control holder
Quantity	1 EA	1 EA	8 EA	8 EA	1 EA	1 SET	1 EA
Shape					 Conduit Bracket  Screw(M4) 2EA	 for gas pipe  for liquid pipe	

# Safety Precautions

To prevent the injury of the user or other people and property damage, the following instructions must be followed.

- Be sure to read before installing the air conditioner.
- Be sure to observe the cautions specified here as they include important items related to safety.
- Incorrect operation due to ignoring instruction will cause harm or damage. The seriousness is classified by the following indications.

**⚠ WARNING** This symbol indicates the possibility of death or serious injury.

**⚠ CAUTION** This symbol indicates the possibility of injury or damage to properties only.

- The meanings of the symbols used in this manual are as shown below.



**Be sure not to do.**



**Be sure to follow the instruction.**

## ⚠ WARNING

### ■ Installation

#### Always perform grounding.

- Otherwise, it may cause electrical shock.

#### Don't use a power cord, a plug or a loose socket which is damaged.

- Otherwise, it may cause a fire or electrical shock.

#### For installation of the product, always contact the service center or a professional installation agency.

- Otherwise, it may cause a fire, electrical shock, explosion or injury.

#### Securely attach the electrical part cover to the indoor unit and the service panel to the outdoor unit.

- If the electrical part cover of the indoor unit and the service panel of the outdoor unit are not attached securely, it could result in a fire or electric shock due to dust, water, etc.

#### Always install an air leakage breaker and a dedicated switching board.

- No installation may cause a fire and electrical shock.

#### Do not keep or use flammable gases or combustibles near the air conditioner.

- Otherwise, it may cause a fire or the failure of product.

#### Ensure that an installation frame of the outdoor unit is not damaged due to use for a long time.

- It may cause injury or an accident.

#### Do not disassemble or repair the product randomly.

- It will cause a fire or electrical shock.

\* The figure can be changed according to model.

**Do not install the product at a place that there is concern of falling down.**

• Otherwise, it may result in personal injury.

**Use caution when unpacking and installing.**

• Sharp edges may cause injury.

**Use a vacuum pump or Inert (nitrogen) gas when doing leakage test or air purge. Do not compress air or Oxygen and Do not use Flammable gases. Otherwise, it may cause fire or explosion.**

• There is the risk of death, injury, fire or explosion.

## ■ Operation

**Do not share the outlet with other appliances.**

• It will cause an electric shock or a fire due to heat generation.

**Do not use the damaged power cord.**

• Otherwise, it may cause a fire or electrical shock.

**Do not modify or extend the power cord randomly.**

• Otherwise, it may cause a fire or electrical shock.

**Take care so that the power cord may not be pulled during operation.**

• Otherwise, it may cause a fire or electrical shock.

**Unplug the unit if strange sounds, smell, or smoke comes from it.**

• Otherwise, it may cause electrical shock or a fire.

**Keep the flames away.**

• Otherwise, it may cause a fire.

**Take the power plug out if necessary, holding the head of the plug and do not touch it with wet hands.**

• Otherwise, it may cause a fire or electrical shock.

**Do not use the power cord near the heating tools.**

• Otherwise, it may cause a fire and electrical shock.

**Do not open the suction inlet of the indoor/outdoor unit during operation.**

• Otherwise, it may electrical shock and failure.

**Do not allow water to run into electrical parts.**

• Otherwise, it may cause the failure of machine or electrical shock.

**Hold the plug by the head when taking it out.**

• It may cause electric shock and damage.

**Never touch the metal parts of the unit when removing the filter.**

• They are sharp and may cause injury.

**Do not step on the indoor/outdoor unit and do not put anything on it.**

• It may cause an injury through dropping of the unit or falling down.

**Do not place a heavy object on the power cord.**

• Otherwise, it may cause a fire or electrical shock.

**When the product is submerged into water, always contact the service center.**

• Otherwise, it may cause a fire or electrical shock.

**Take care so that children may not step on the outdoor unit.**

• Otherwise, children may be seriously injured due to falling down.

 **CAUTION****■ Installation**

**Install the drain hose to ensure that drain can be securely done.**

- Otherwise, it may cause water leakage.

**Always inspect gas leakage after the installation and repair of product.**

- Otherwise, it may cause the failure of product.

**Install the product so that the noise or hot wind from the outdoor unit may not cause any damage to the neighbors.**

- Otherwise, it may cause dispute with the neighbors.

**Keep level parallel in installing the product.**

- Otherwise, it may cause vibration or water leakage.

**■ Operation**

**Avoid excessive cooling and perform ventilation sometimes.**

- Otherwise, it may do harm to your health.

**Do not use an appliance for special purposes such as preserving animals vegetables, precision machine, or art articles.**

- Otherwise, it may damage your properties.

**Use a soft cloth to clean. Do not use wax, thinner, or a strong detergent.**

- The appearance of the air conditioner may deteriorate, change color, or develop surface flaws.

**Do not place obstacles around the flow inlet or outlet.**

- Otherwise, it may cause the failure of appliance or an accident.

# Installation of Indoor, Outdoor Unit

Read completely, then follow step by step.

## Select the best location

### Indoor unit

1. Do not have any heat or steam near the unit.
2. Select a place where there are no obstacles in front of the unit.
3. Make sure that condensation drainage can be conveniently routed away.
4. Do not install near a doorway.
5. Ensure the unit is unobstructed, allow proper space on all sides according to the arrows and distance measurements in the figures.
6. Use a Metal Detector or Metal Scanner to locate studs to prevent unnecessary damage to the wall.

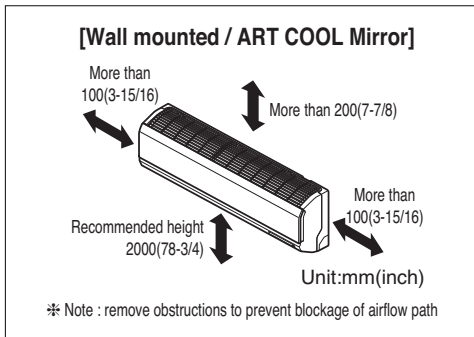

### [Ceiling Concealed Duct Type]

#### Top view

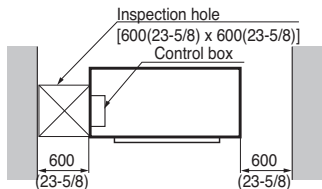

#### Front view

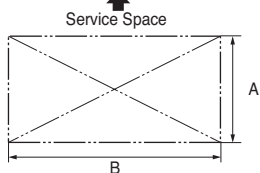
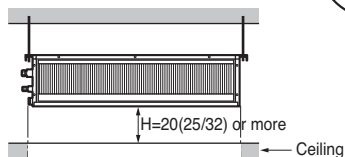

\* Suitable dimension "H" is necessary to get a slope to drain as show in the figure.

Capacity(Btu/h class)	A	B
9/12k	600(23-5/8)	900(35-7/16)
18k	600(23-5/8)	1100(43-5/16)

### [Ceiling Cassette Type]

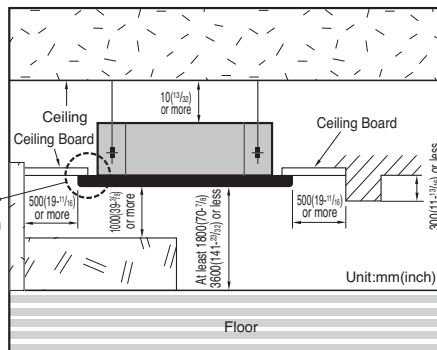

### [ART COOL Gallery]

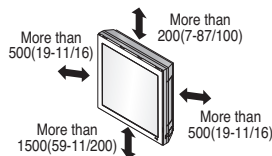

## Outdoor unit

1. If an awning is built over the unit to prevent direct sunlight or rain exposure, make sure that heat radiation from the condenser is not restricted.
2. Ensure the unit is unobstructed, allow proper space on all sides according to the arrows and distance measurements in the figures.
3. Do not place animals and plants in the path of the warm air.
4. Take the air conditioner weight into account and select a place where noise and vibration are minimum.
5. Select a place so that the warm air and sound from the air conditioner does not disturb neighbors.

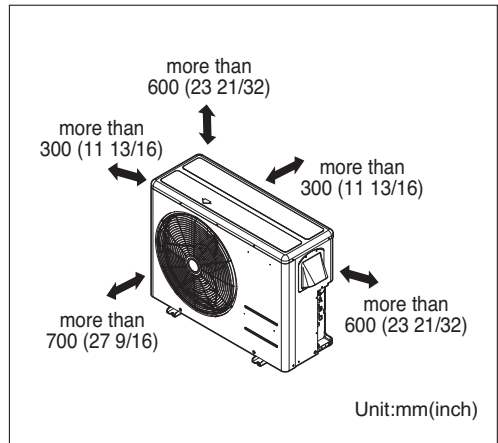

## Rooftop Installations:

If the outdoor unit is installed on a roof structure, be sure to level the unit. Ensure the roof structure and anchoring method are adequate for the unit location. Consult local codes regarding rooftop mounting.

## Seaside Applications and Installation

### ⚠ CAUTION

1. Air conditioners should not be installed in areas where corrosive gases, such as acid or alkaline gas, are produced.
2. Do not install the product where it could be exposed to sea wind (salty wind) directly. It can result corrosion on the product. Corrosion, particularly on the condenser and evaporator fins, could cause product malfunction or inefficient performance.
3. If outdoor unit is installed close to the seaside, it should avoid direct exposure to the sea wind.

### 1. Selecting the location(Outdoor Unit)

- 1) If the outdoor unit is to be installed close to the seaside, direct exposure to the sea wind should be avoided. Install the outdoor unit on the opposite side of the sea wind direction.

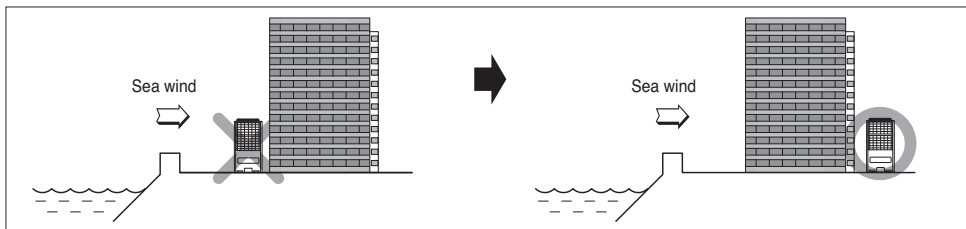

- 2) In case, to install the outdoor unit on the seaside, set up a windbreaker/barrier, to lessen the unit's exposure to sea air

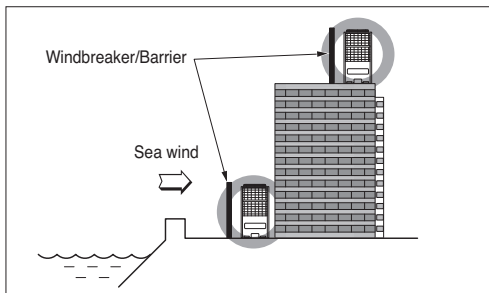

- It should be strong enough (like concrete) to obstruct the wind from the sea.
- The height and width should be more than 150% of the outdoor unit.
- A minimum of 70cm (27 1/16 inches) of space between outdoor unit and the windbreak for easy air flow.

- 3) Select a well-drained place.

Periodic ( more than once/year ) cleaning of the dust or salt particles stuck on the heat exchanger using water is recommended.

## Seasonal Wind And Cautions In Winter

- Sufficient measures are required in a snow area or severe cold area in winter so that product can be operated well.
- Get ready for seasonal wind or snow in winter even in other areas.
- Install a suction and discharge duct not to let in snow or rain.
- Install the outdoor unit not to come in contact with snow directly. If snow piles up and freezes on the air suction hole, the system may malfunction. If it is installed at snowy area, attach the hood to the system.
- Install the outdoor unit at the higher installation console by 50cm than the average snowfall (annual average snowfall) if it is installed at the area with much snowfall.
- Where snow accumulated on the upper part of the Outdoor Unit by more than 10cm, always remove snow for operation.

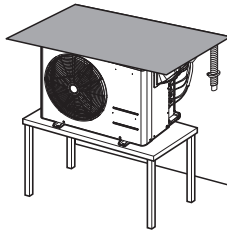

1. The height of H frame must be more than 2 times the snowfall and its width shall not exceed the width of the product. (If width of the frame is wider than that of the product, snow may accumulate)
2. Don't install the suction hole and discharge hole of the Outdoor Unit facing the seasonal wind.

## Piping length and elevation

### Multi Piping Type

Unit : m(ft)

Outdoor Unit Capacity (Btu/h class)	Max total length of all pipes (A+B)/(A+B+C)/ (A+B+C+D)	Max length of each pipe (A/B/C/D)	Min length of each pipe (A/B/C/D)	Max Elevation between each indoor unit and outdoor unit (h1)	Max elevation between indoor units (h2)	Max. Combination of Indoor unit (Btu/h class)
18k	50(164)	25(82)	3(10)	15(49)	7.5(25)	24k
24k	75(246)	25(82)	3(10)	15(49)	7.5(25)	33k
36k	75(246)	25(82)	3(10)	15(49)	7.5(25)	48k

Indoor unit Capacity (Btu/h class)	Pipe Diameter Unit : mm(inch)	
	Gas	Liquid
9k	9.52(3/8)	6.35(1/4)
12k	9.52(3/8)	6.35(1/4)
18k	12.7(1/2)	6.35(1/4)

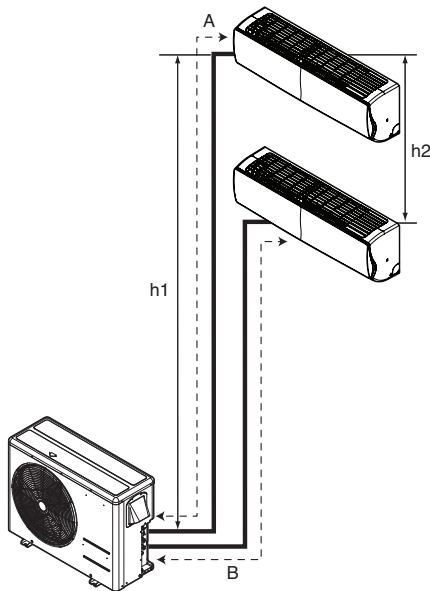

Multiple Piping Type



**CAUTION: Capacity is based on standard length and maximum allowance length is on the basis of reliability.**

### Distributor Piping Type

Unit : m(ft)

Outdoor Unit Capacity (Btu/h class)	Max total length of all pipes (Main + Branch pipes)	Max length of Main pipe (A+B+C)	Max length of Branch pipes	Max length of each Branch pipe	Min length of each pipe (Main / Branch pipes)	Max Elevation Between each indoor unit and outdoor unit (h1)	Max Elevation Between indoor (h2)	Max Combination of indoor unit
54k	145(476)	55(180)	90(295)	15(49)	3(10)	30(98)	15(49)	73k

Indoor unit Capacity (Btu/h class)	Pipe Diameter Unit : mm(inch)	
	Gas	Liquid
9k	9.52(3/8)	6.35(1/4)
12k	9.52(3/8)	6.35(1/4)
18k	12.7(1/2)	6.35(1/4)

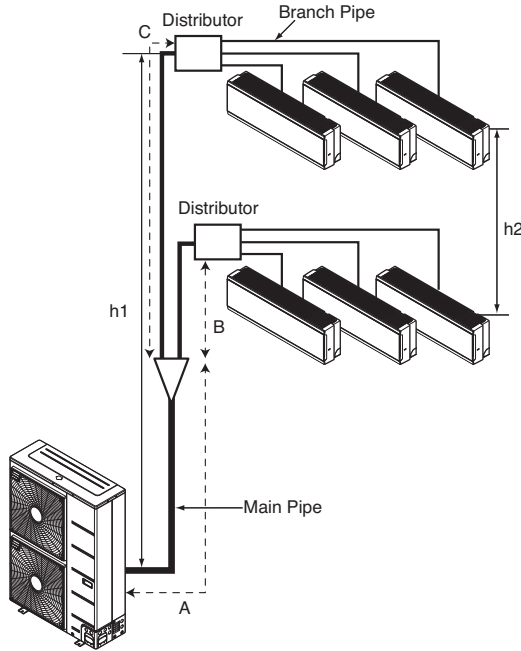

**CAUTION:** Capacity is based on standard length and maximum allowance length is on the basis of reliability.

# Installation

[Wall mounted / ART COOL Mirror]

## Connecting the piping

### # Standard / Artcool Mirror Type

1. Prepare the indoor unit's piping and drain hose for installation through the wall.
2. Remove the plastic tubing retainer (see the illustration on the right) and pull the tubing and drain hose away from chassis.
3. Route the indoor tubing and the drain hose to the required piping hole position.
4. Insert the piping, drain hose, and the connecting cable into the piping hole.
5. Insert the connecting cable into the indoor unit.
  - Don't connect the cable to the indoor unit.
  - Make a small loop with the cable for easy connection later.
6. Tape the tubing and drain hose.

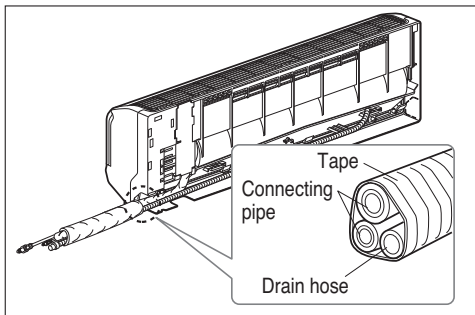
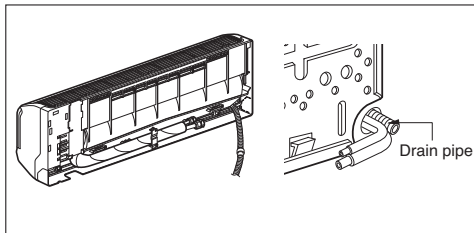
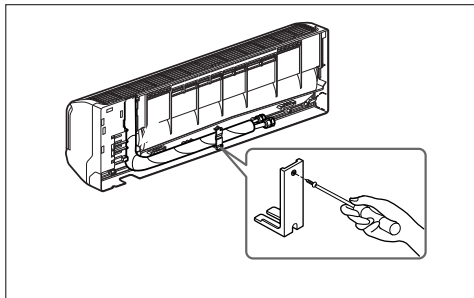

For right rear piping

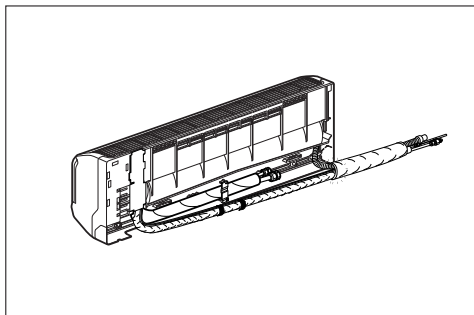

For left rear piping

### 7. Indoor unit installation

- Hang the indoor unit from the hooks at the top of the installation plate.
- Insert the spacer etc. between the indoor unit and the installation plate and separate the bottom of the indoor unit from the wall.

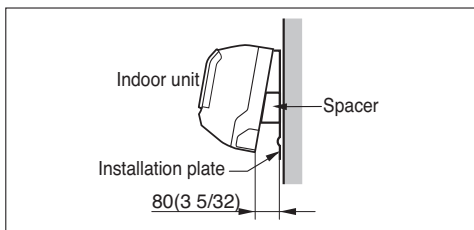

**# Standard Libero / Artcool Libero Type**

1. Pull the screw cap at the bottom of the indoor unit
2. Remove the chassis cover from the unit by loosening screws

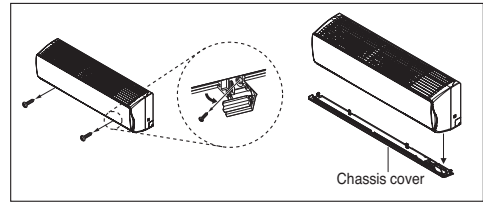

3. Pull back the tubing holder.
4. Remove pipe port cover and positioning the tubing

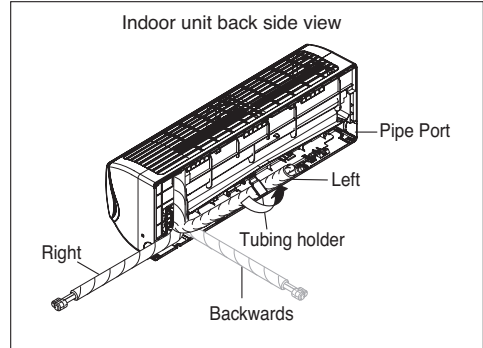
**5. Indoor unit installation**

- 1) Hook the indoor unit onto the upper portion of the installation plate. (engage the three hooks at the top of the indoor unit with the upper edge of the installation plate) Ensure that the hooks are properly seated on the installation plate by moving it left and right
- 2) Unlock the tubing holder from the chassis and mount between the chassis and installation plate in order to separate the bottom side of the indoor unit from the wall

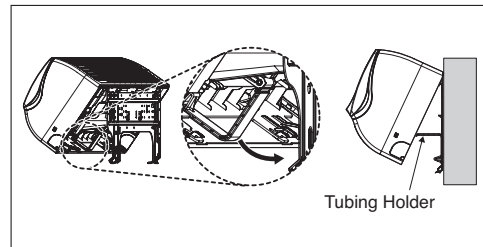
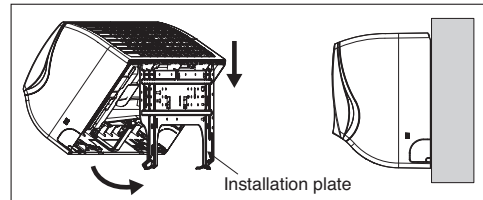

### Connecting the piping to the indoor unit and drain hose to drain pipe.

1. Align the center of the pipes and sufficiently tighten the flare nut by hand.
2. Tighten the flare nut with a wrench.

Outside diameter		Torque			
mm	inch	N. m	kgf.m	lbf.ft	
Ø6.35	1/4	14~18	1.4~1.8	10~13	
Ø9.52	3/8	34~42	3.5~4.3	25~31	
Ø12.7	1/2	49~61	5.0~6.2	36~45	
Ø15.88	5/8	69~82	7.0~8.4	51~60	
Ø19.05	3/4	100~120	10.0~12.2	73~88	

3. Next, extend the indoor unit's drain hose. Then attach the drain pipe.

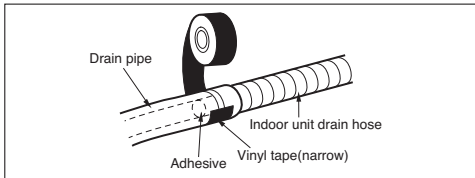
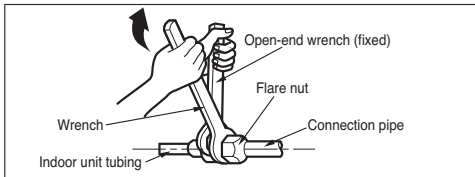
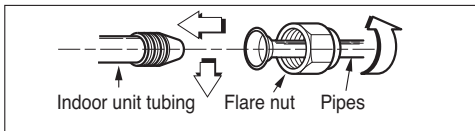

### ⚠ CAUTION

Installation Information. For left piping. Follow the instruction below.

#### Good case

- Press on the upper side of clamp and unfold the tubing to slowly downward.

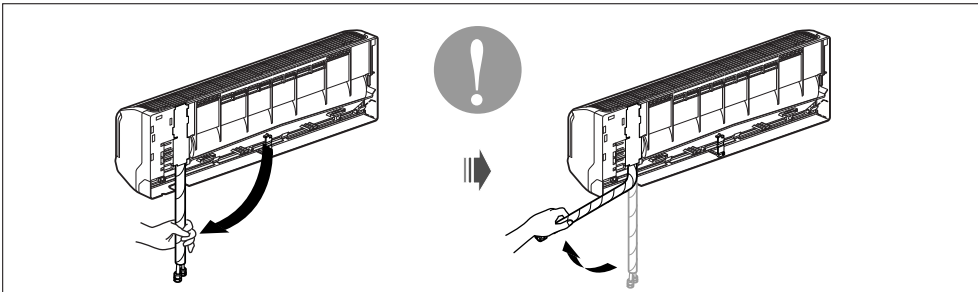

#### Bad case

- Bending the pipe from right to left may cause damage to the tubing.

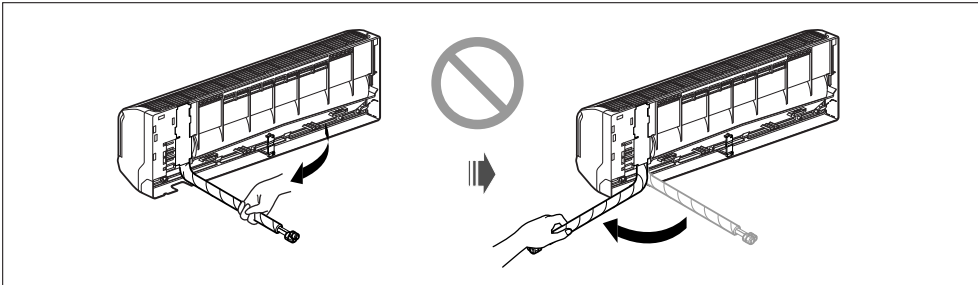

### Wrap the insulation material around the connecting portion.

1. Overlap the connection pipe insulation and the indoor unit pipe heat insulation material. Bind them together with vinyl tape so that there is no gap.
2. Wrap the area which accommodates the rear piping housing section with vinyl tape.

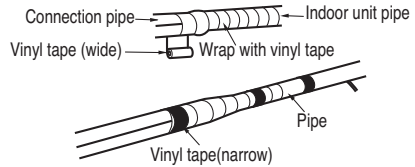
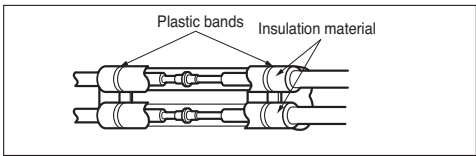

3. Bundle the piping and drain hose together by wrapping them with vinyl tape over the range within which they fit into the rear piping housing section.

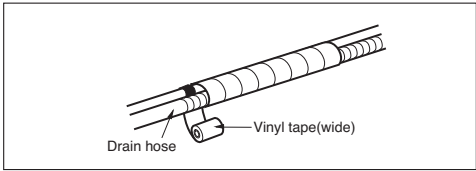

### Reroute the pipings and the drain hose across the back of the chassis.

#### Finishing the indoor unit installation

##### # Standard / Artcool Mirror Type

1. Remove the spacer.
2. Ensure that the hooks are properly seated on the installation plate by moving it left and right.
3. Press the lower left and right sides of the unit against the installation plate until the hooks engage into their slots (clicking sound).

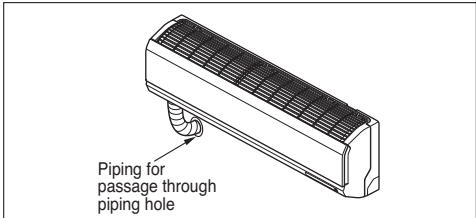

##### # Standard Libero / Artcool Libero Type

1. Mount the tubing holder in the original position.
2. Ensure that the hooks are properly seated on the installation plate by moving it left and right.
3. Press the lower left and right sides of the unit against the installation plate until the hooks engage into their slots (clicking sound).
4. Finish the assembly by screwing the unit to the installation plate by using two pieces of type "C" screws. And assemble a chassis cover.

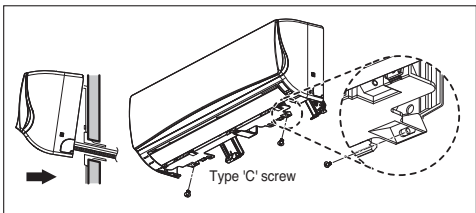
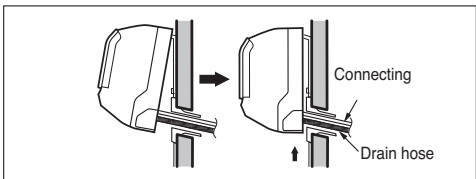

### ⚠ CAUTION

If the split type Indoor unit is installed in a wall having hole or opening near by or back side of the unit, then the air from other side of the wall can come inside the condition space through that hole / opening. That air can cause unwanted dew / water droplet formation when it comes in contact with body of the indoor unit. So all hole or opening on the wall must be blocked very well to avoid water dropping from the body of the unit.

## Installation of filters

- 1) Detach two attached tapes from the plasma filter.

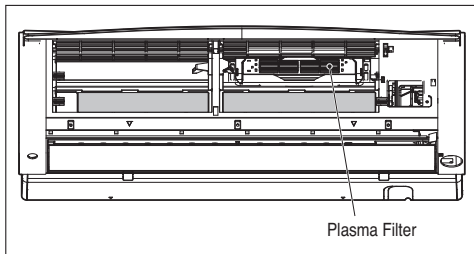

## How To Fix

The wall you select should be strong and solid enough to prevent vibration

1. Mount the installation plate on the wall with type "A" screws. If mounting the unit on a concrete wall, use anchor bolts.
  - Mount the installation plate horizontally by aligning the centerline using a level.
2. Measure the wall and mark the centerline. It is also important to use caution concerning the location of the installation plate-routing of the wiring to power outlets is through the walls typically. Drilling the hole through the wall for piping connections must be done safely.

Indoor Type	Capacity (kBtu/h)	Type
Wall mounted / ART COOL Mirror	9/12	Type 1 / Type 3
	18	Type 2 / Type 4

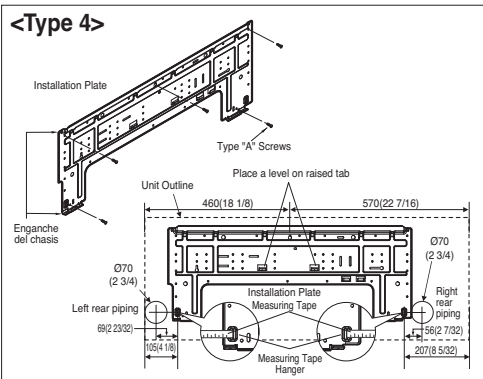
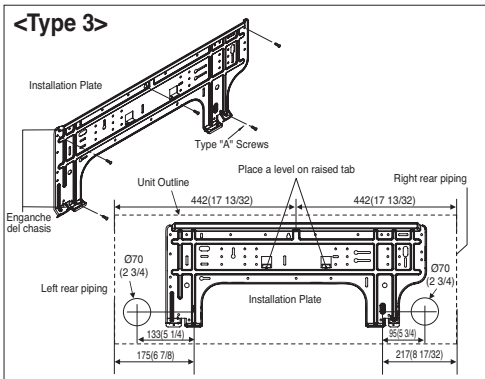
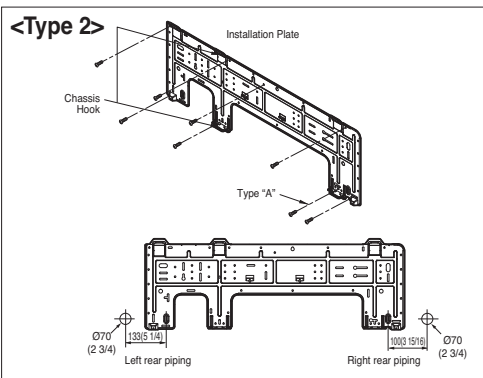
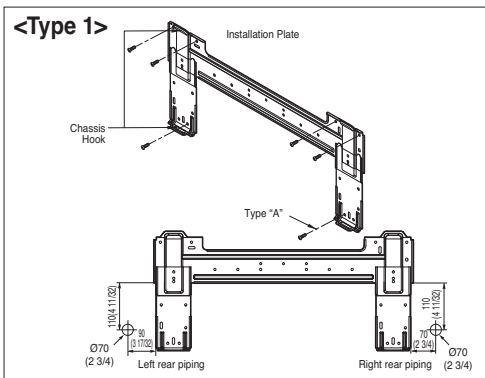

## Wiring Connection

1. Connect the wires to the terminals on the control board individually according to the outdoor unit connection.
  - Ensure that the color of the wires of outdoor unit and the terminal No. are the same as those of indoor unit respectively.

Terminal Block in Indoor				
1(L1)	2(L2)		3	4

↑ ↑ ↑ ↑  
Connected to Outdoor Unit

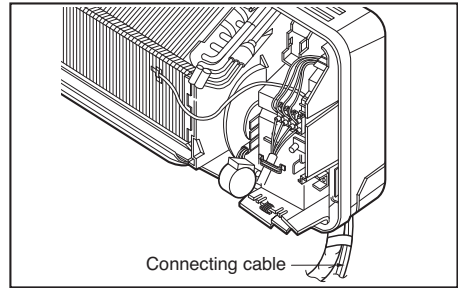

2. Attach the Grille onto the cabinet.
  - Grasp the lower left and right side of the Grille and engage four tabs on the top inside edge of the chassis.
  - Press the Grille toward the chassis until it goes back into place.

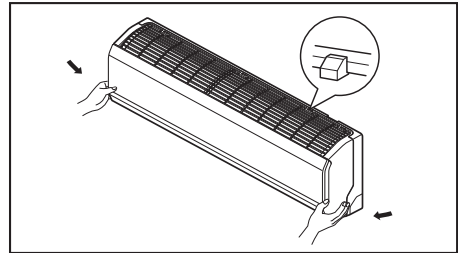

## Conduit connection

1. Set the connecting cable into the terminal block of indoor unit, and tighten set screw to lock the conduit bracket to the indoor unit.
2. Join the conduit and the conduit bracket together.



**CAUTION :** Must use the elbow type (L-Type) conduit.

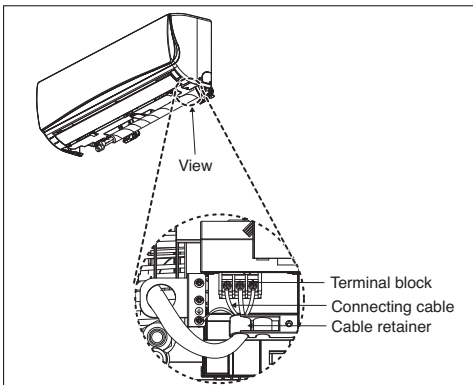
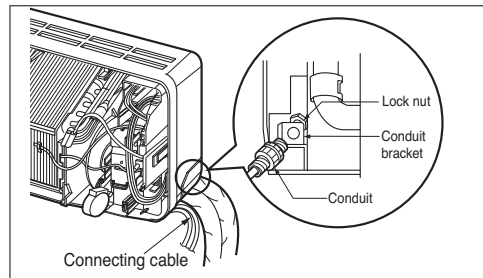
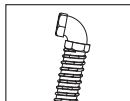

[Ceiling Cassette Type]

**Ceiling dimension and hanging bolt location**

• The dimensions of the paper model for installation are the same as those of the ceiling opening dimensions.

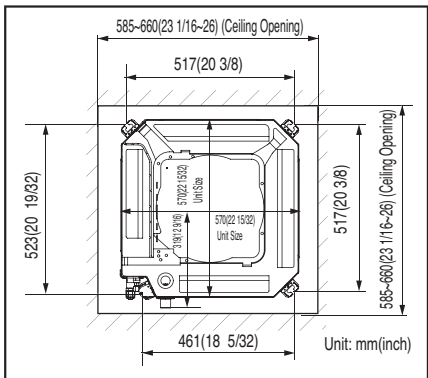
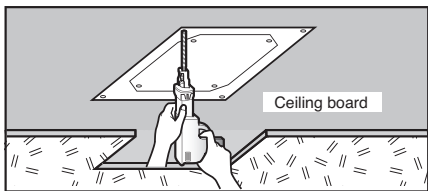
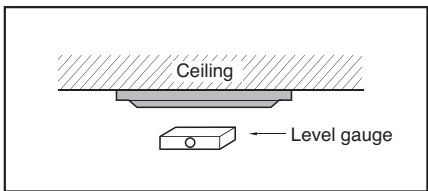

- Select and mark the position for fixing bolts and piping hole.
- Decide the position for fixing bolts slightly tilted to the drain direction after considering the direction of drain hose.
- Drill the hole for anchor bolt on the wall.



**CAUTION :**

- This air-conditioner uses a drain pump.
- Install the unit horizontally using a level gauge.
- During the installation, care should be taken not to damage electric wires.

**NOTICE**

- Avoid the following installation location.
  1. Such places as restaurants and kitchen where considerable amount of oil steam and flour is generated. These may cause heat exchange efficiency reduction, or water drops, drain pump mal-function. In these cases, take the following actions;
    - Make sure that ventilation fan is enough to cover all noxious gases from this place.
    - Ensure enough distance from the cooking room to install the air conditioner in such a place where it may not suck oily steam.
  2. Avoid installing air conditioner in such places where cooking oil or iron powder is generated.
  3. Avoid places where inflammable gas is generated.
  4. Avoid place where noxious gas is generated.
  5. Avoid places near high frequency generators.

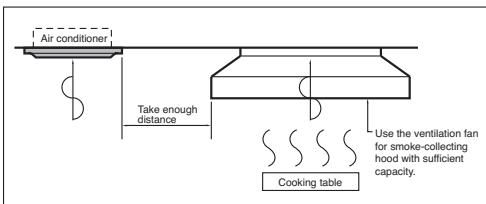

## How to Fix

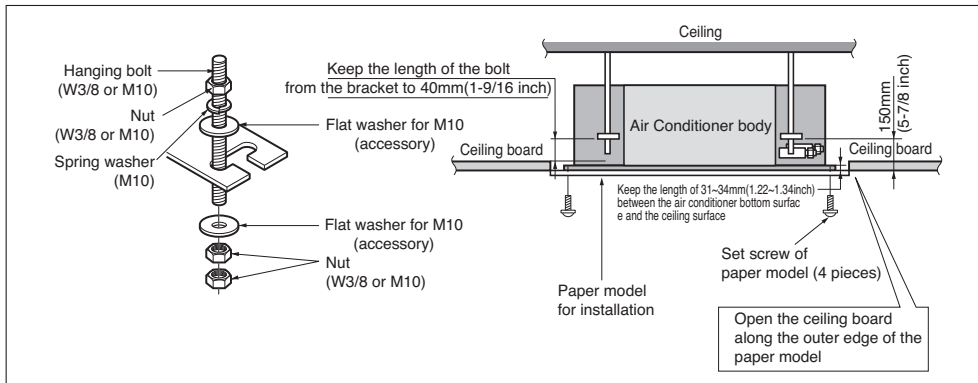

• The following parts are local purchasing.

- ① Hanging Bolt - W 3/8 or M10
- ② Nut - W 3/8 or M10
- ③ Spring Washer - M10
- ④ Plate Washer - M10



**CAUTION : Tighten the nut and bolt to prevent unit from falling off.**

## Wiring Connection

• Open the control box cover and connect the remote control cord and indoor power wires.

**TQ/TR series**

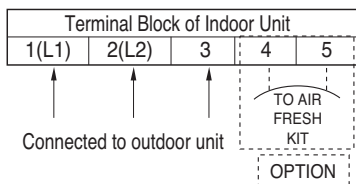

## Conduit connection

- Remove the busing rubber product attached on the indoor unit.
- Join the conduit and the conduit bracket together using nut.
- Set the connecting cable into the terminal block of indoor unit, and tighten set screw to lock the conduit bracket to the indoor unit.

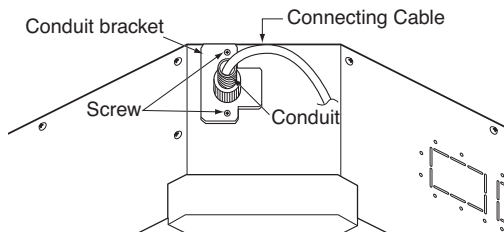

## Installation of Wired Remote Controller(Optional)

### 1. Please fix tightly using provided screw after placing remote controller setup board on the place where you like to setup.

- Please set it up not to bend because poor setup could take place if setup board bends.  
Please set up remote controller board fit to the reclamation box if there is a reclamation box.
- Install the product so as not to make a gap with the wall side and to prevent shaking after the installation.

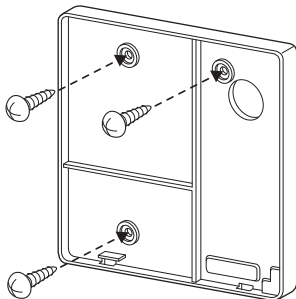

### 2. Can set up Wired remote controller cable into three directions.

- Setup direction: the surface of wall reclamation, upper, right
- If setting up remote controller cable into upper and right side, please set up after removing remote controller cable guide groove.

※ Remove guide groove with long nose.

- ① Reclamation to the surface of the wall
- ② Upper part guide groove
- ③ Right part guide groove

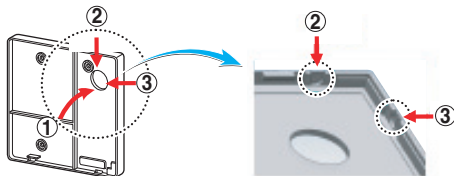

<Wire guide grooves>

### 3. Please fix remote controller upper part into the setup board attached to the surface of the wall, as the picture below, and then, connect with setup board by pressing lower part.

- Please connect not to make a gap at the remote controller and setup board's upper and lower, right and left part.
- Before assembly with the installation board, arrange the Cable not to interfere with circuit parts.

<Connecting order>

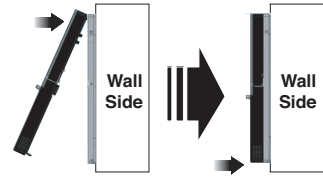

When separating remote controller from setup board, as the picture below, after inserting into the lower separating hole using screw driver and then, spinning clockwise, remote controller is separated.

- There are two separating holes. Please individually separate one at a time.
- Please be careful not to damage the inside components when separating.

<Separating order>

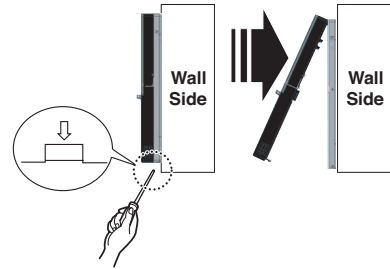

### 4. Please connect indoor unit and remote controller using connection cable.

12V	Red
Signal	Yellow
GND	Black

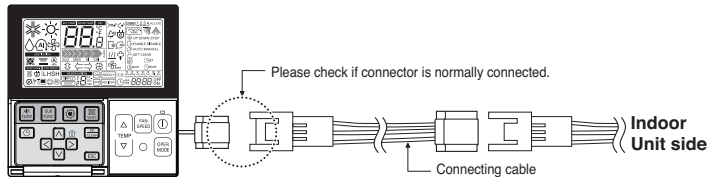

### 5. Please use extension cable if the distance between wired remote controller and indoor unit is more than 10m(32.8ft).

#### ⚠ CAUTION

When installing the wired remote controller, do not bury it in the wall.

(It can cause damage in the temperature sensor.)

Do not install the cable to be 50m(164ft) or above.

(It can cause communication error.)

- When installing the extension cable, check the connecting direction of the connector of the remote controller side and the product side for correct installation.
- If you install the extension cable in the opposite direction, the connector will not be connected.
- Specification of extension cable: 2547 1007 22# 2 core 3 shield 5 or above.

## Installation of Decorative Panel

**The decorative panel has its installation direction.  
Before installing the decorative panel, always remove the paper template.**

1. Remove the packing and take out air inlet grille from front panel.

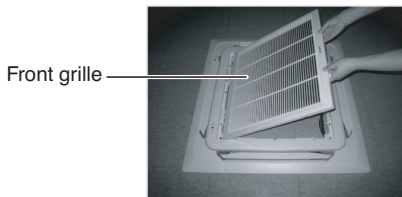

2. Remove the Corner covers of the panel.

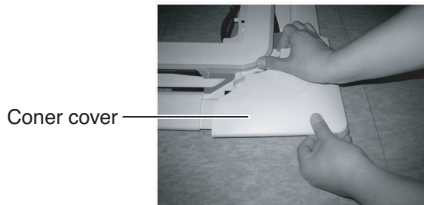

3. Fit the panel on the unit by inserting hooks as shown in picture.

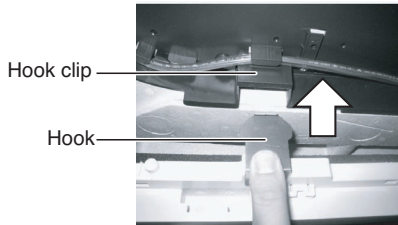

4. Insert two screws on diagonal corners of panel. Do not tighten the bolts completely. (The fixing screws are included in the indoor unit box.)

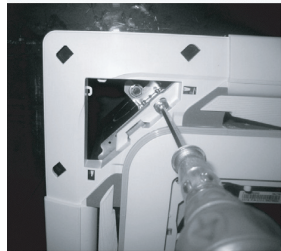

Check the alignment of panel with the ceiling. Height can be adjusted using hanging bolts as shown in picture. Insert the other two screws and tighten all screws completely.



5. Fit the corner covers.

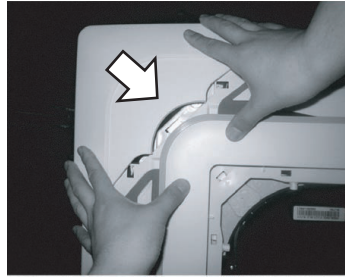

6. Open two screws of control panel cover.

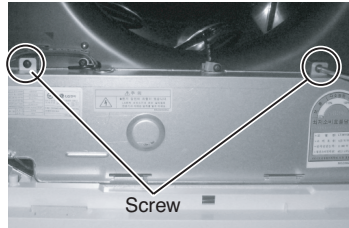

7. Connect one display connector and two vane control connectors of front panel to indoor unit PCB.

The position marking on PCB is as:

Display connector : CN-DISPLAY

Vane control connector: CN-VANE 1,2

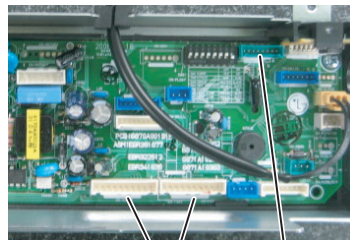

CN-VANE 1,2 CN-DISPLAY

8. Close the cover for control box.

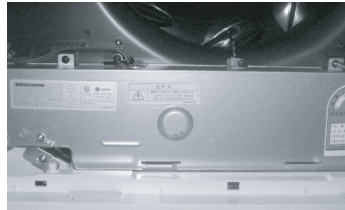

9. Install the air inlet grille and Filter on the panel.

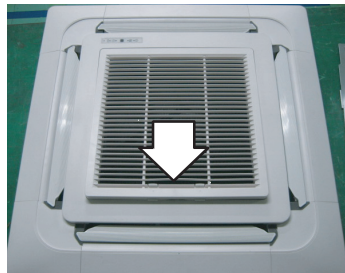

**CAUTION:** Install certainly the decorative panel.  
Cool air leakage causes sweating. ⇨ Water drops fall.

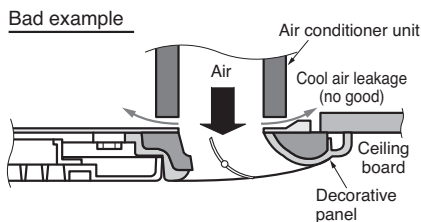
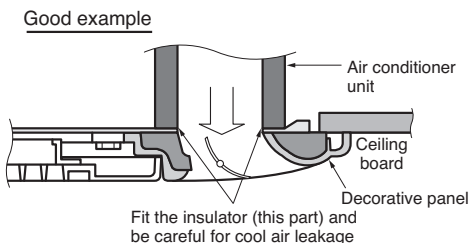

## HEAT INSULATION

1. Use the heat insulation material for the refrigerant piping which has an excellent heat-resistance [over 120°C(248°F)].

2. Precautions in high humidity circumstance:

This air conditioner has been tested according to the "KS Standard Conditions with Mist" and confirmed that there is not any default. However, if it is operated for a long time in high humid atmosphere [dew point temperature: more than 23°C(73.4°F)], water drops are liable to fall. In this case, add heat insulation material according to the following procedure:

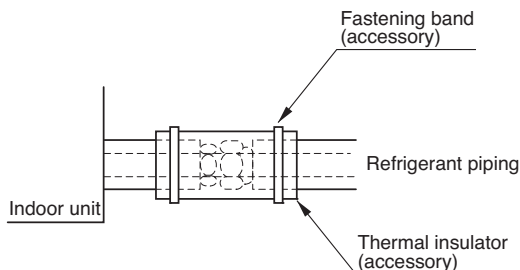

- Heat insulation material to be prepared... Adiabatic glass wool with thickness 10 to 20mm.
- Stick glass wool on all air conditioners that are located in ceiling atmosphere.

## Drain Piping

[Standard / Standard Libero / Artcool Mirror Type]

1. The drain hose should point downward for optimum drainage.

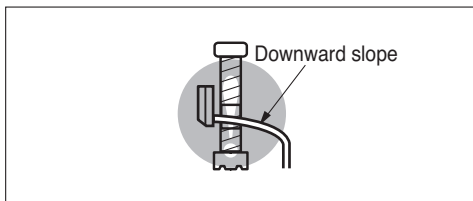

2. Incorrect Installation Examples:

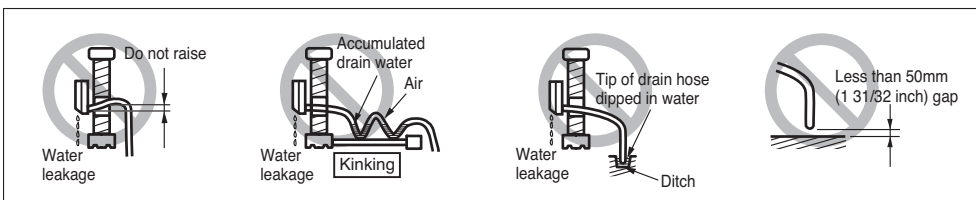

## [Ceiling Concealed Duct/Ceiling Cassette Type]

- Drain piping must have down-slope (1/50 to 1/100): be sure not to provide up-and-down slope to prevent reversal flow.
- During drain piping connection, be careful not to exert extra force on the drain port on the indoor unit.
- The outside diameter of the drain connection on the indoor unit is 32mm(1 1/4 inch).

Piping material: Polyvinyl chloride pipe inner diametes  $\varnothing$  25mm(1 inch) and pipe fittings

- Be sure to install heat insulation on the drain piping.

Heat insulation material: Polyethylene foam with thickness more than 8mm(5/16 inch).

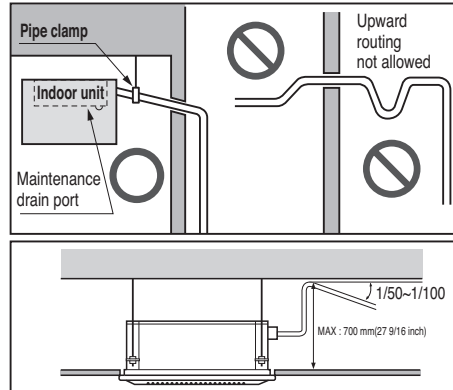

### Drain test

The air conditioner uses a drain pump to drain water. Use the following procedure to test the drain pump operation:

- Connect the main drain pipe to the exterior and leave it provisionally until the test comes to an end.
- Feed water to the flexible drain hose and check the piping for leakage.
- Be sure to check the drain pump for normal operating and noise when electrical wiring is complete.
- When the test is complete, connect the flexible drain hose to the drain port on the indoor unit.

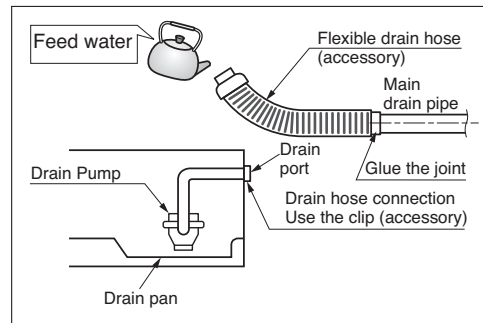

**CAUTION : The supplied flexible drain hose should not be curved, neither screwed. The curved or screwed hose may cause a leakage of water.**

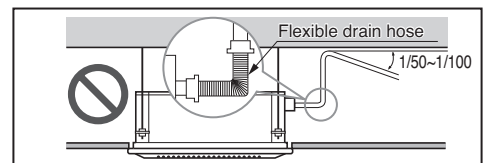

\* The figure can be changed according to model.

## Attention

1. Possible drain-head height is up to 700mm(27 9/16 inch). So, it must be installed below 700mm(27 9/16 inch).
2. Keep the drain hose downward up to 1/50~1/100 inclination. Prevent any upward flow or reverse flow in any part.
3. 5mm(3/16 inch) or thicker formed thermal insulator is provided for the drain pipe.

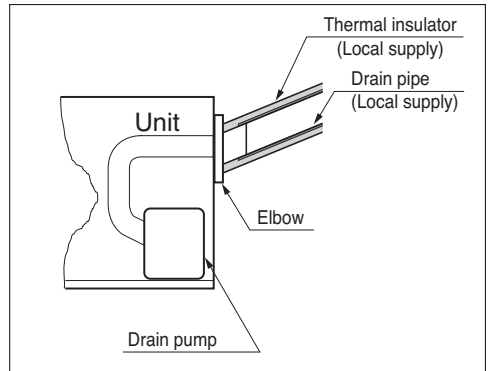
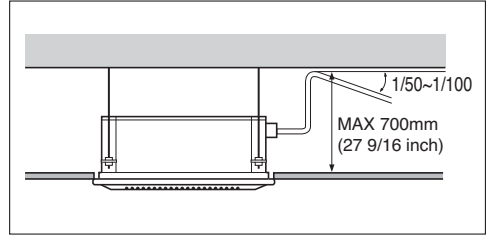

4. Upward routing is not allowed.
5. Be sure to check the drain pump for normal operation and abnormal noise when electrical wiring is complete.

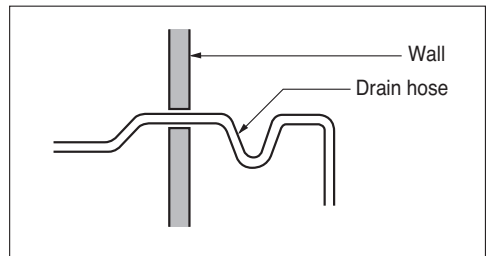

# Flaring Work and Connection of Piping

## Flaring work

Main cause of gas leakage is defect in flaring work. Carry out correct flaring work in the following procedure.

### 1) Cut the pipes and the cable.

- Use the accessory piping kit or the pipes purchased locally.
- Measure the distance between the indoor and the outdoor unit.
- Cut the pipes a little longer than measured distance.
- Cut the cable 1.5m(4.9ft) longer than the pipe length.

### 2) Burrs removal

- Completely remove all burrs from the cut cross section of pipe/tube.
- Put the end of the copper tube/pipe to downward direction as you remove burrs in order to avoid to let burrs drop in the tubing.

### 3) Putting nut on

- Remove flare nuts attached to indoor and outdoor units, than put them on pipe/tube having completed burr removal.  
(Not possible to put them on after flaring work)

### 4) Flaring work

- Carry out flaring work using flaring tool as shown below.

Outside diameter		A	
mm	inch	mm	inch
Ø6.35	1/4	1.1~1.3	0.04~0.05
Ø9.52	3/8	1.5~1.7	0.06~0.07
Ø12.7	1/2	1.6~1.8	0.06~0.07
Ø15.88	5/8	1.6~1.8	0.06~0.07
Ø19.05	3/4	1.9~2.1	0.07~0.08

Firmly hold copper tube in a bar(or die) as indicated dimension in the table above.

### 5) Check

- Compare the flared work with figure.
- If flare is noted to be defective, cut off the flared section and do flaring work again.

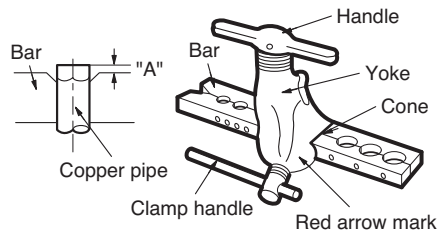
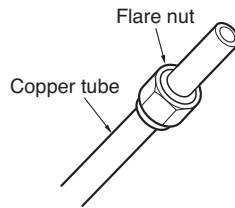
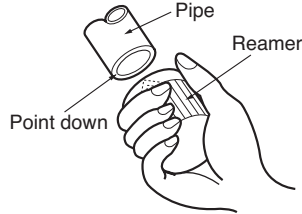
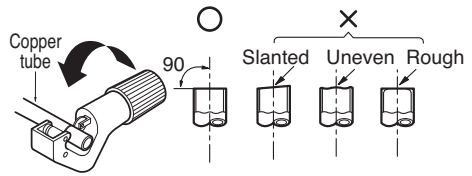

Smooth all round  
Inside is shining without scratches.

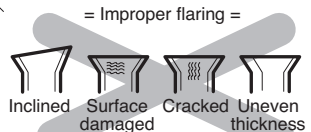
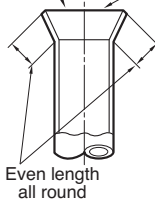

## Connection of piping - Outdoor

Align the center of the piping and sufficiently tighten the flare nut by hand.

Connecting pipe order

- 1) ROOM A~C gas side pipe
- 2) ROOM A~C liquid side pipe

Finally, tighten the flare nut with torque wrench until the wrench clicks.

- When tightening the flare nut with torque wrench ensure the direction for tightening follows the arrow on the wrench.

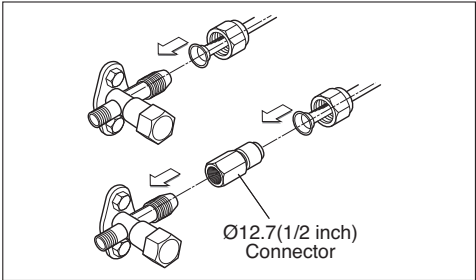

Outside diameter		Torque		
mm	inch	N. m	kgf.m	lbf.ft
Ø6.35	1/4	14~18	1.4~1.8	10~13
Ø9.52	3/8	34~42	3.5~4.3	25~31
Ø12.7	1/2	49~61	5.0~6.2	36~45
Ø15.88	5/8	69~82	7.0~8.4	51~60
Ø19.05	3/4	100~120	10.0~12.2	73~88

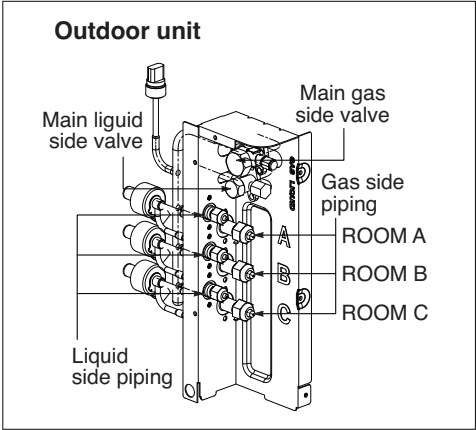

- For the units with capacity more than 48 kBTU/h, the installation piping is connectable in four directions.(refer to figure 1)
- When connecting in a downward direction, knock out the knockout hole of the base pan. (refer to figure 2)

**Preventing foreign objects from entering (Figure3)**

- Plug the pipe through-holes with putty or insulation material(procured locally)to stop up all gaps,as shown in the figure 3.
- Insects or small animals entering the outdoor unit may cause a short circuit in the electrical box.

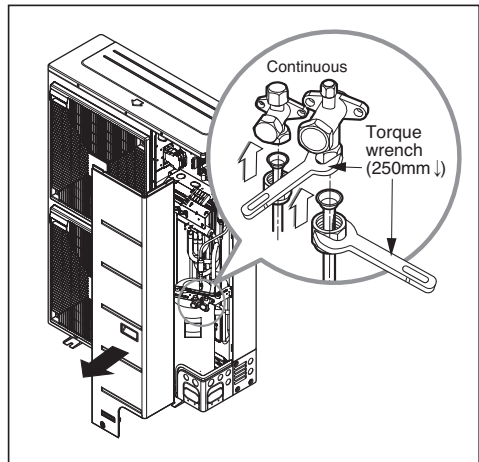

\* When tighten the pipe, hold the hexagonal body.

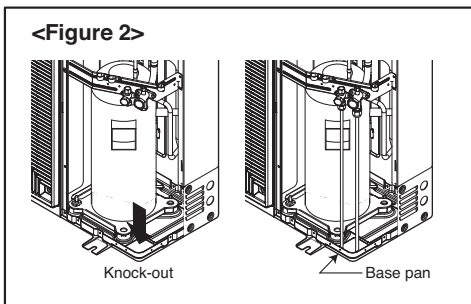
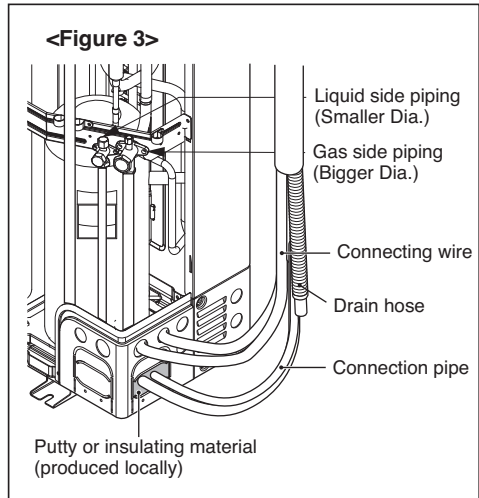
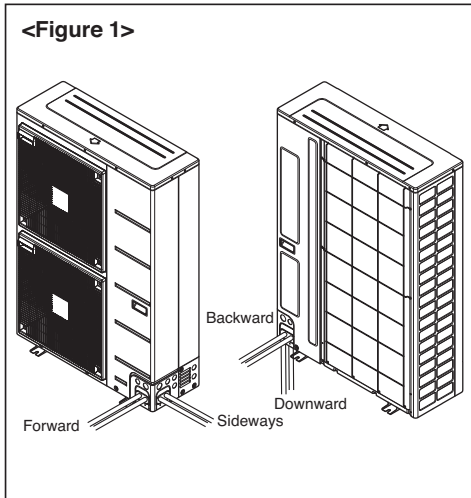

**Branch**

[unit:mm]

Model	Gas Pipe	Liquid Pipe
PMBL5620		

■ Y branch

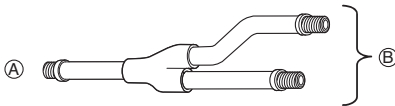

- Ⓐ To Outdoor Unit
- Ⓑ To BD Unit

- Ensure that the branch pipes are attached horizontally or vertically (see the diagram below.)

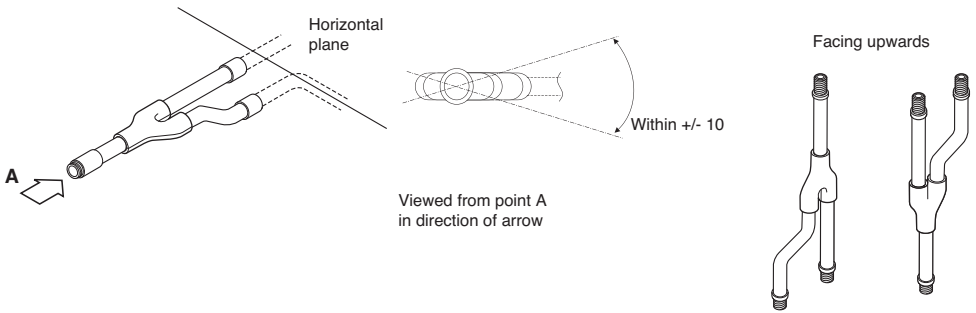

- Branch pipe should be insulated with the insulator in each kit.

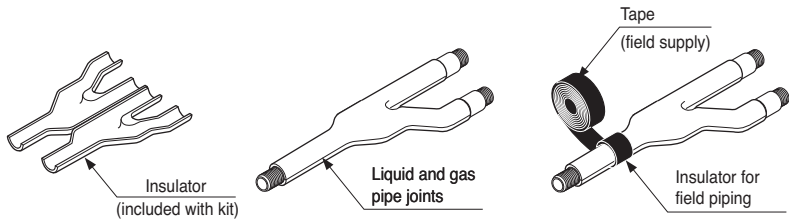

## Installation

- This unit may be installed suspended from the ceiling or mounted on the wall.
- This unit may only be installed horizontally, as shown in the diagram below. (Side B is facing up) However, it may be freely installed in any direction forward or back, and to the sides.
- Be sure to leave a 600mm square opening for service and inspection as shown in the diagram below, for both ceiling - suspended installation and wall-mounted installation.
- This unit "does not require drain treatment" as it uses internal foam treatment as low-pressure piping insulation.
- Service direction is the side B and C
- The piping for the indoor unit may be led around in direction A
- The inclination of side B must be within  $\pm 5$  degrees forward or back or to the sides.

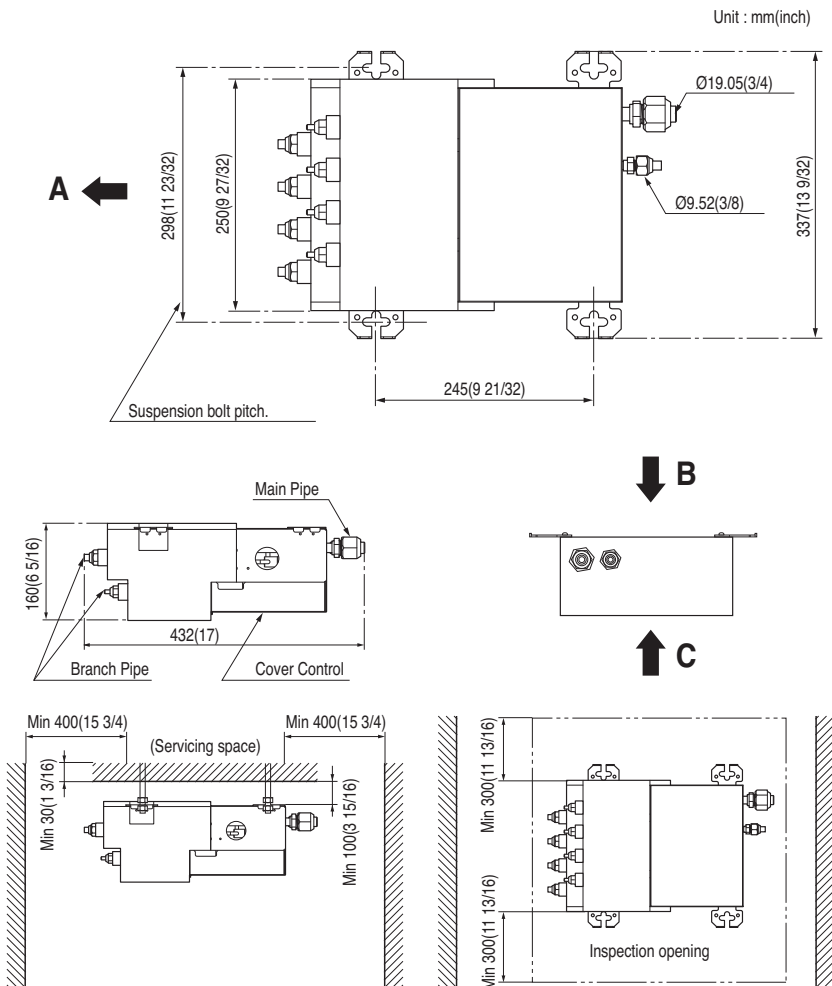

## Installation of The Main Unit

**NOTICE :**

- This unit has two different installation types:  
(1) Ceiling-suspended type and (2) wall-mounted type.
- Choose the proper installation pattern according to the location of installation.
- The installation location for printed wiring board can be changed.  
Follow the procedure specified in the "CONNECTING THE WIRING" section to change the location.

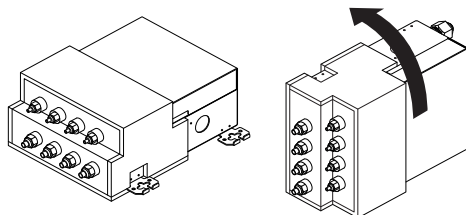

(1) Ceiling-suspended type

(2) Wall-mountde type

### (1) Ceiling-suspended type

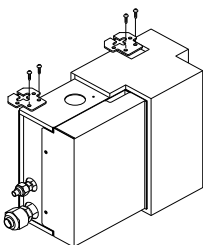
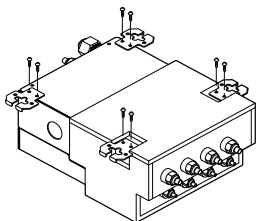

### (2) Wall-mounted type

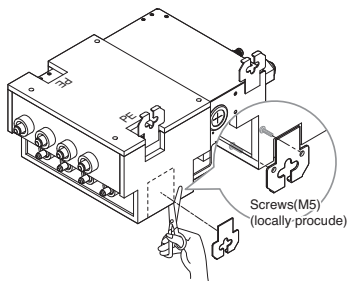

### Procedure

- (1) Fix the furnished hanger metal with two screws.(4 locations in total).
- (2) Using an insert-hole-in- anchor, hang the hanging bolt.
- (3) Install a hexagon nut and a flat washer (locally-procured)to the hanging bolt as shown in the figure in the left, and lift the main unit to hang on the hanger metal.
- (4) After checking with a level that the unit is level, tighten the hexagon nut.  
\* The tilt of the unit should be within  $\pm 5^\circ$  in front/back and left/right.

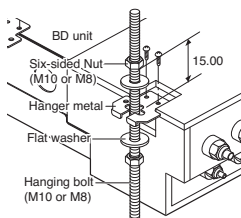

### Procedure

- (1) Fix the furnished hanger metal with two screws.  
(3 locations in total).
- (2) After checking with a level that the unit is level, fix the unit with the furnished wood screws.  
\* The tilt of the unit should be within  $\pm 5^\circ$  in front/back and left/right.  
\* Block up the parts of hanger holes (2 places) by using insulation PE after installing the hanger.



**CAUTIONS**

- Once a screw-hole on the main unit has had a screw hammered in, make sure to either hammer it again or cover it with aluminum tape.(This is to prevent condensation)
- Be sure to install the unit with the ceiling-side up.
- Do not install near bedrooms. the sound of refrigerant flowing through the piping may sometimes be audible.

# Connecting the Cable between Indoor Unit, Distributor Unit and Outdoor Unit

## Connect the cable to the Indoor unit.

Connect the cable to the indoor unit by connecting the wires to the terminals on the control board individually according to the outdoor unit connection. (Ensure that the color of the wires of the outdoor unit and the terminal No. are the same as those of the indoor unit.)

The ground wire should be longer than the common wires.

The circuit diagram is not subject to change without notice.

When installing, refer to the electrical diagram behind the front panel of Indoor Unit.

The wiring for the outdoor unit can be found on the inside of the Outdoor Unit control cover.



### RECOMMENDATION:

- The circuit diagram is subject to change without notice.
- Be sure to connect wires according to the wiring diagram.
- Connect the wires firmly, so that they can not be pulled out easily.
- Connect the wires according to color codes by referring to the wiring diagram.



**RECOMMENDATION:** Provide a circuit breaker between power source and the outdoor unit as shown below.

Outdoor Unit Capacity (Btu/h class)	Power source	Fuse or breaker Capacity
18/24k	1ø,208/230V	20A
36k	1ø,208/230V	25A
54k	1ø,208/230V	40A

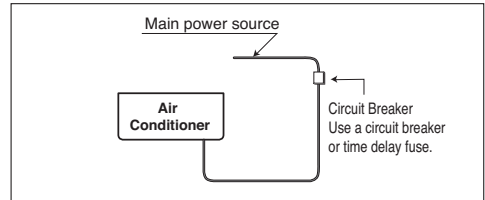

**RECOMMENDATION:** The power cord connected to the outdoor unit should comply with the following specifications: NRTL Recognized (for example, UL or ETL recognized and CSA certified).

### ■ Power supply cable

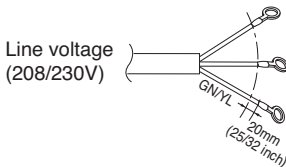

As always, final wire selection is governed by local codes and should be installed by a licensed professional contractor.

	The minimum recommended wire size
18/24k Btu/h	AWG 14-3
36k Btu/h	AWG 12-3
54k Btu/h	AWG 8-3

### ■ Connecting cable

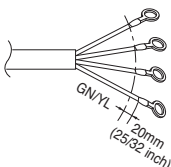

The power connecting cable between the outdoor and indoor units must comply with the following specifications: NRTL Recognized (for example, UL or ETL recognized and CSA certified).

AWG 18-4 is the minimum recommended wire size, however, the selected conductors must comply with local codes and be suitable for installation in wet locations.



**RECOMMENDATION:** When using separate wires as the power cord, please secure separate wires in the control box panel using tie wraps to hold all wires in place.

## Connect the cable to the Distributor unit.

- Connect refrigerant pipes and connection wires to the appropriate ports marked with matching alphabets (A, B and C) on this unit.
- Follow the instructions on the wiring nameplate to connect the connection wires of indoor/outdoor units to terminal board numbers.(1, 2 and 3) Always fix each ground wire separately with a ground screw.(See the figure below.)
- After completing the wiring, fix the outer coating of wires securely with wire clamps. The wire clamp on indoor unit side is furnished. Follow the procedure below to install.
- Refer to the circuit diagram on the control cover inside outdoor unit.

**NOTICE :**  
**The terminal board numbers are arranged from top to bottom in order of 1, 2 and 3.**

### In Case of 3 rooms

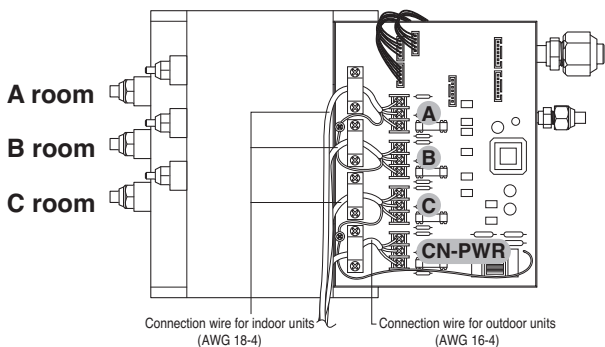

**Warning**  
 Do not use tapped wires, stand wires, extensioncords, or starburst connections, as they may cause overheating, electrical shock, or fire.

- (1) Remove the control cover. Loosen the two screws, and slide the cover in the direction of the arrow.

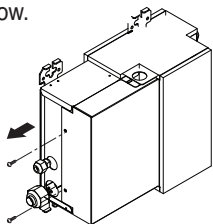

- (2) Pull out connection cable through conduit. After conduit to the panel, fix nut to the opposite side of panel. Pass the connection cable through the hole.

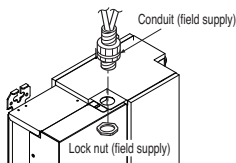

- (3) Perform wiring with reference the wiring diagram on a control cover of outdoor unit. Allow 300 mm(11 13/16 inch) for the pulling-out section of harness. Fix the wires completely with wire clamps(4 locations).

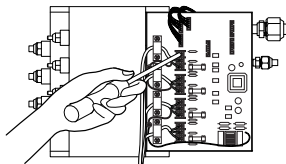

- (4) Put in the cover in the direction of the arrow then tighten the screws.

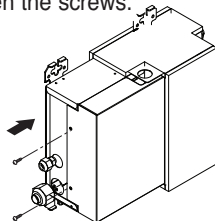

# Connect the cable to the Outdoor unit.

1. Remove the control cover from the unit by loosening the screw.  
Connect the wires to the terminals on the control board individually as the following.
2. Secure the cable onto the control board with the holder (clammer).
3. Re-attach the cover control to the original position using the screws.

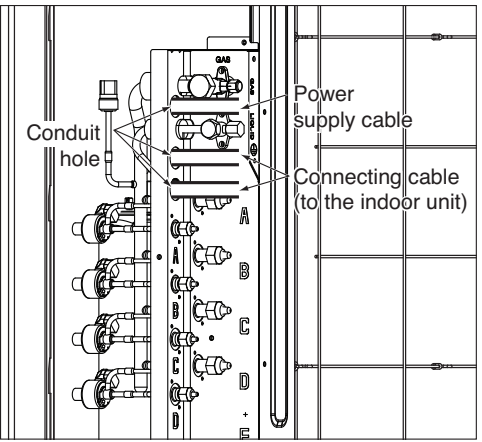

## 18kBTu/h class

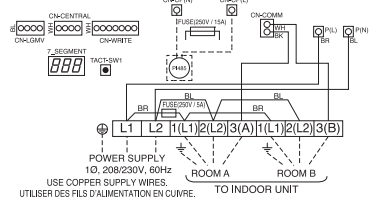

## 24kBTu/h class

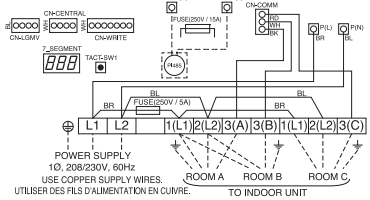

## 36 kBTu/h class

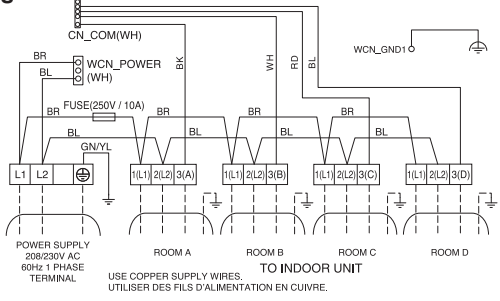

## 54 kBTu/h class

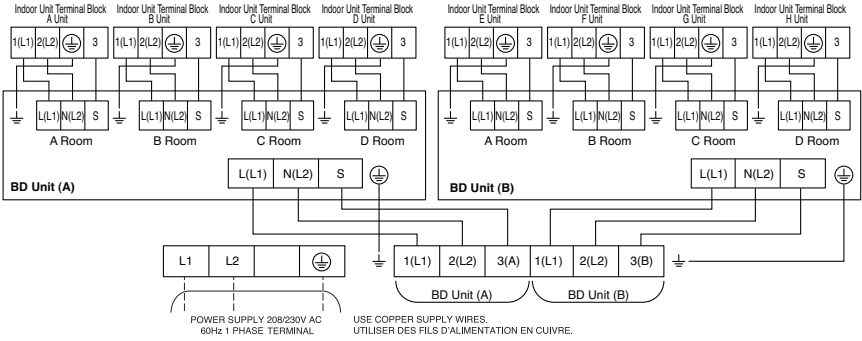

**NOTICE :**

1. Use connection cable NRTL(UL, ETL, CAS...) listed and stranded copper(4) THHN conductors, sunlight (UV) resistant ROHS compliant PVC jacket 600V direct burial listed, approved for wet conditions. Temperature rated for  $-20^{\circ}\text{C}(-4^{\circ}\text{F})$  to  $90^{\circ}\text{C}(194^{\circ}\text{F})$ . And this cable should be enclosed in conduit.



**WARNING:**

- Be sure to comply with local and national codes while running the wire from the indoor unit to the outdoor unit(size of wire and wiring method, etc).
- Every wire must be connected firmly.
- No wire should be allowed to touch refrigerant tubing, the compressor or any moving parts.
- The communication wirings of air conditioner should be separate and isolated from external device's electric wiring such as computers, elevator, radio & Television broadcasting facilities, as well as medical imaging offices.

## Connection method of the connecting cable(Example)

- (1) Remove the side panel and knockouts of conduit panel. (for low voltage line)
- (2) Pull out connection cable through conduit.
- (3) After conduit to the panel, fix nut to the opposite side of panel.
- (4) Pass the connection cable through the hole.
- (5) Properly connect the cable on the terminal block.
- (6) Fix the connection cable with cord clamp provided on the unit not to have strain at the terminal when the connection cable is pulled outside up to a 35 pound weight



**WARNING: Loose wiring may cause the terminal to overheat or result in unit malfunction. A fire hazard may also exist. Therefore, be sure all wiring is tightly connected.**

When connecting each power wire to the corresponding terminal, follow instructions "How to connect wiring to the terminals" and fasten the wire tightly with the fixing screw of the terminal plate.

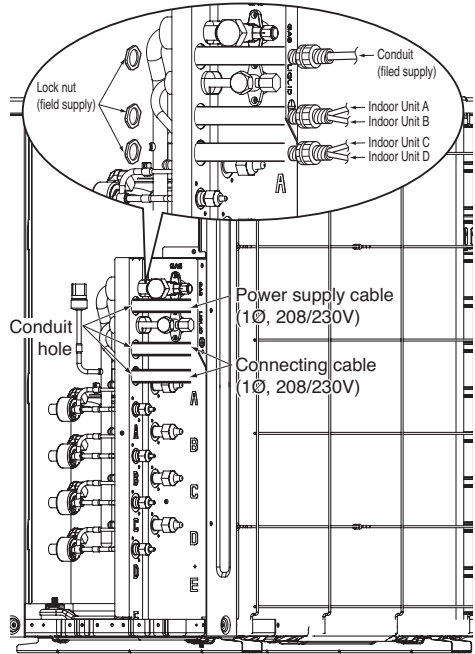

### How to connect wiring to the terminals

□ For strand wiring

- (1) Cut the wire end with a wire cutter or wire-cutting pliers, then strip the insulation to expose the strand wiring about 10 mm (3/8").
- (2) Using a screwdriver, remove the terminal screw(s) on the terminal plate.
- (3) Using a round terminal fastener or pliers, securely clamp each stripped wire end with a round terminal.
- (4) Position the round terminal wire, and replace and tighten the terminal screw using a screwdriver.

#### Power supply cable

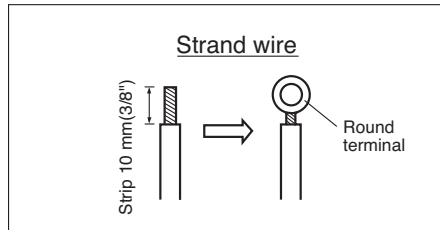

#### Connecting Cable

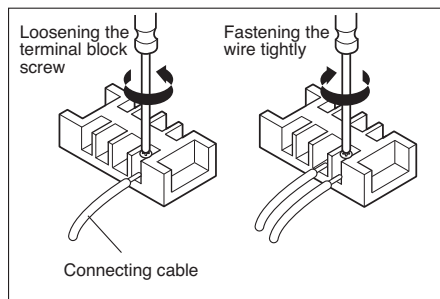

# Checking the Drainage, Insulating the Pipe and Special Piping Applications

## Checking the drainage

### 1. Remove the Air Filter.

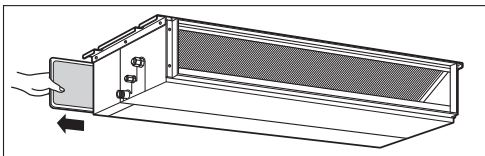

### 2. Check the drainage.

- Spray one or two glasses of water upon the evaporator.
- Ensure that water flows drain hose of indoor unit without any leakage.

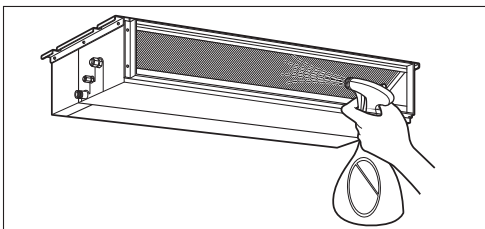

※ The figure can be changed according to model.

## Insulating the Pipe and Special Piping Applications

**Insulate the piping by wrapping the connecting portion of the indoor unit with insulation material and secure it with two kinds of vinyl tape.**

- If you want to connect an additional drain hose, the end of the drain outlet should be routed above the ground. Secure the drain hose appropriately.

**In cases where the outdoor unit is installed below the indoor unit perform the following:**

1. Tape the piping, drain hose and connecting cable from down to up.
2. Secure the taped piping along the exterior wall using saddle or equivalent.

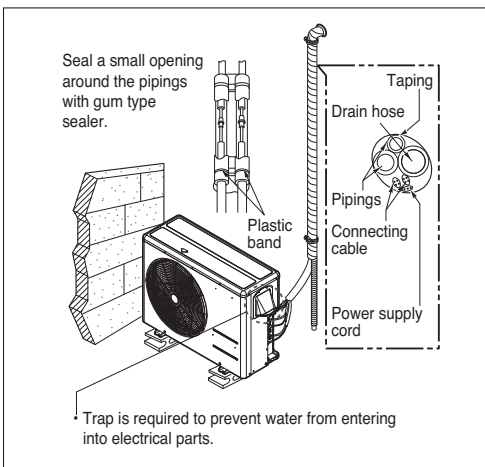

**In cases where the Outdoor unit is installed above the Indoor unit perform the following.**

1. Tape the piping and connecting cable from down to up.
2. Secure the taped piping along the exterior wall. Form a trap to prevent water entering the room.
3. Secure the piping onto the wall using a saddle or equivalent.

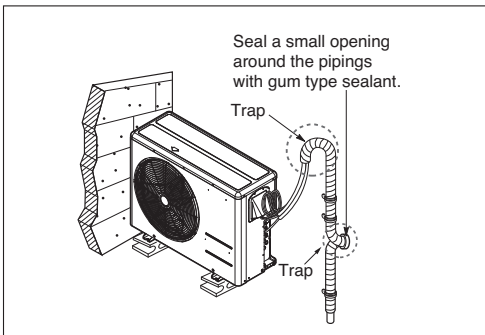

# Air Purging and Evacuation

Air and moisture remaining in the refrigerant system have undesirable effects as indicated below.

1. Pressure in the system rises.
2. Operating current rises.
3. Cooling(or heating) efficiency drops.
4. Moisture in the refrigerant circuit may freeze and block capillary tubing.
5. Water may lead to corrosion of parts in the refrigeration system.

Therefore, the indoor/outdoor unit and connecting tube must be checked for leaks, and vacuumed to remove incondensable gas and moisture in the system.

## Leak Checking

### Preparation

- Check that each tube(both liquid and gas side tubes) between the indoor and outdoor units have been properly connected and all wiring for the test run has been completed. Remove the service valve caps from both the gas and the liquid sides on the outdoor unit. Check that both the liquid and the gas side service valves on the outdoor unit are kept closed at this stage.

### Leakage test

- Connect the manifold valve(with pressure gauges) and dry nitrogen gas cylinder to this service port with charge hoses.

**CAUTION:** Be sure to use a manifold valve for leak testing. The high side manifold valve must always be kept closed.

- Pressurize the system to no more than 550 P.S.I.G. with dry nitrogen gas and close the cylinder valve when the gauge reading reached 550 P.S.I.G. Next, test for leaks with liquid soap.

**CAUTION:** To avoid nitrogen entering the refrigerant system in a liquid state, the top of the cylinder must be higher than its bottom when you pressurize the system. Usually, the cylinder is used in a vertical standing position.

**NOTICE :** Leakage testing should be done for each indoor unit connection set, separately.

1. Do a leakage test of all joints of the tubing(both indoor and outdoor) and both gas and liquid side service valves with soap bubbles. Bubbles indicate a leak. Be sure to wipe off the soap with a clean cloth.
2. After the system is found to be free of leaks, relieve the nitrogen pressure by loosening the charge hose connector at the nitrogen cylinder. When the system pressure is reduced to normal, disconnect the hose from the cylinder.

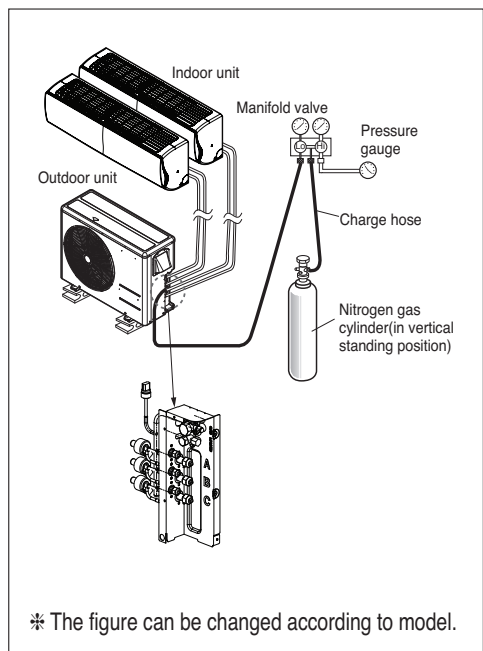

## Evacuation

1. Connect the charge hose end described in the preceding steps to the vacuum pump to evacuate the tubing and indoor unit. Confirm the "Lo" knob of the manifold valve is open. Then, run the vacuum pump. The operation time for evacuation varies with tubing length and capacity of the pump. The following table shows the time required for evacuation.

Required time for evacuation when 30 gal/h vacuum pump is used	
If tubing length is less than 10m (33 ft)	If tubing length is longer than 10m (33 ft)
Less than 0.5 Torr	Less than 0.5 Torr

2. When the desired vacuum is reached, close the "Lo" knob of the manifold valve and stop the vacuum pump.

### Finishing the job

1. With a service valve wrench, turn the valve stem of liquid side valve counter-clockwise to fully open the valve.
2. Turn the valve stem of gas side valve counter-clockwise to fully open the valve.
3. Loosen the charge hose connected to the gas side service port slightly to release the pressure, then remove the hose.
4. Replace the flare nut and its bonnet on the gas side service port and fasten the flare nut securely with an adjustable wrench. This process is very important to prevent leakage from the system.
5. Replace the valve caps at both gas and liquid side service valves and fasten them tight.

This completes air purging with a vacuum pump. The air conditioner is now ready for test running.

### NOTICE

**: Repeat evacuation procedure for each indoor unit.**

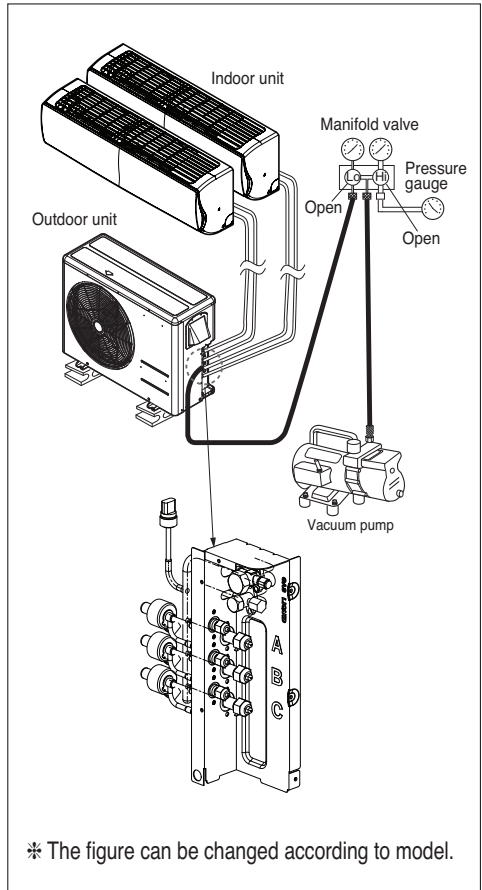

\* The figure can be changed according to model.

# Charging

- If installed total piping length is more than standard total length, additional refrigerant charging is necessary.

Below standard total piping length, additional refrigerant charging is not required.

## Multiple Piping Models

Unit:m(ft)

Outdoor Unit Capacity (Btu/h class)	Max total length of all pipes (A+B)/(A+B+C)/(A+B+C+D)	Max length of each pipe (A/B/C/D)	Min length of each pipe (A/B/C/D)	Additional Refrigerant Unit : g/m (oz/ft)	Standard Total Piping Length (No Add'l refrigerant)
18k	50(164)	25(82)	3(9.8)	20(0.22)	15(49.2)
24k	75(246)	25(82)	3(9.8)	20(0.22)	22.5(74)
36k	75(246)	25(82)	3(9.8)	20(0.22)	30(98.4)

## Distributor Type Model

Unit:m(ft)

Outdoor Unit Capacity (Btu/h class)	Main Piping Length		Branch Piping Length	
	Standard Length	Additional Refrigerant Unit : g/m (oz/ft)	Standard Length	Additional Refrigerant Unit : g/m (oz/ft)
54k	5(16.4)	50(0.55)	5(16.4)	20(0.22)

### Important:

If you are ever uncertain of the unit charge, reclaim, evacuate and weigh in the correct charge using the charge amount specified on the Unit's specification label.

## Multiple Piping Models

Additional charge(oz) = (Total Installation Piping Length-Standard Total Piping Length) x 0.22

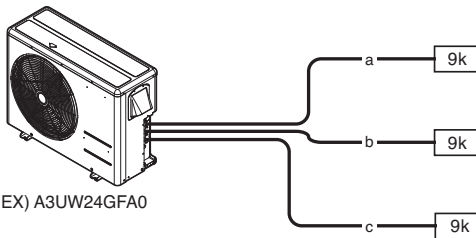

Each branch pipe  
 a=82ft  
 b=16ft  
 c=49ft

Additional Charge  
 = {(82+16+49)-98.4} x 0.22 = 10.69 oz

### Distributor type Models

$$\begin{aligned} \text{Additional charge (oz)} = & ((\text{Total Main piping Length} - \text{Main Standard Length}) \times 0.55 \\ & + (\text{A Room Branch Length} - \text{Standard Length}) \times 0.22 \\ & + (\text{B Room Branch Length} - \text{Standard Length}) \times 0.22 \\ & + (\text{C Room Branch Length} - \text{Standard Length}) \times 0.22 + \dots) \\ & - \text{CF}(\text{Correction Factor}) \times 3.53 \end{aligned}$$

\* CF = Max. number of connectable indoor unit – Total number of connected indoor unit

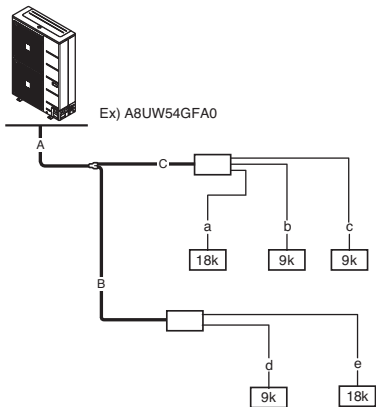

- Total main pipe(A+B+C)=98ft
- Each branch pipe  
 a=33ft  
 b=26ft  
 c=16.4ft  
 d=10ft  
 e=33ft

$$\begin{aligned} \text{❖ Additional Charge} & = ((98-16.4) \times 0.55 + (33-16.4) \times 0.22 \\ & + (26-16.4) \times 0.22 + (16.4-16.4) \times 0.22 \\ & + (10-16.4) \times 0.22 + (33-16.4) \times 0.22) \\ & - (8-5) \times 3.53 = 42.3\text{oz} \end{aligned}$$

\* If the total additional charge value after calculation comes out to be negative, then do not consider additional charge.

# Installation PI485

Fix the PI485 PCB as shown in Fig.

Detailed installation method refer to PI485 Installation Manual.

18k Btu/h, 24k Btu/h

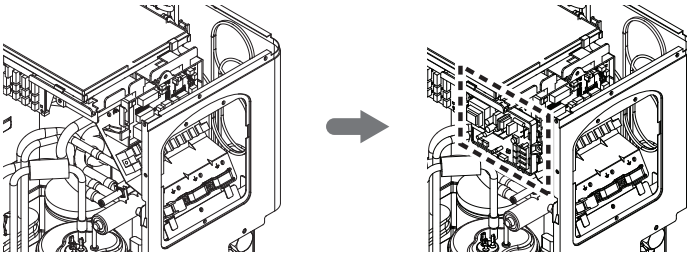

36k Btu/h

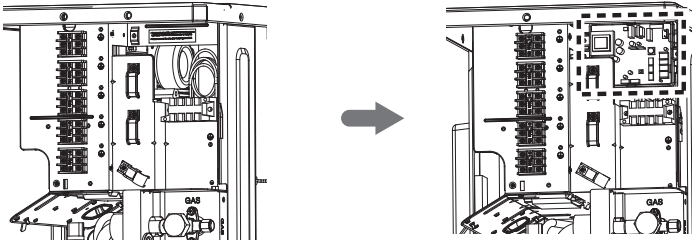

54k Btu/h

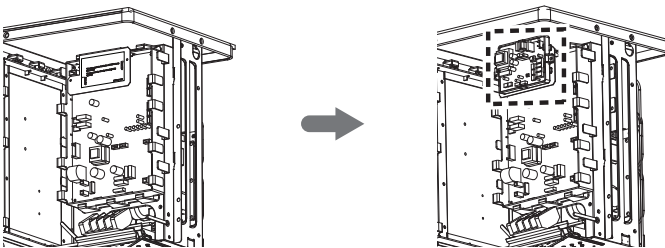

# Test Running

- Check that all tubing and wiring have been properly connected.
- Check that the gas and liquid side service valves are fully open.

## Prepare remote control

Remove the battery cover by pulling it according to the arrow direction. Insert new batteries making sure that the (+) and (-) of battery are installed correctly. Reattach the cover by pushing it back into position.

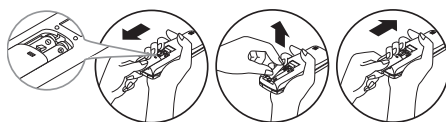

### NOTICE :

- Use 2 AAA(1.5volt) batteries. Do not use rechargeable batteries.
- Remove the batteries from the remote control if the system is not going to be used for a long time.

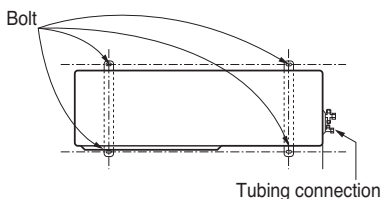

## Evaluation of the performance

Operate unit for 15~20 minutes, then check the system refrigerant charge:

- Measure the pressure of the gas side service valve.
- Measure the temperature of the intake and discharge of air.
- Ensure the difference between the intake temperature and the discharge is more than 8°C.
- For reference, the gas side pressure of optimum condition is as below.(Cooling)

Refrigerant	Outside ambient TEMP.	The pressure of the gas side service valve.
R410A	35°C (95°F)	8.5~9.5kg/cm2G (120~135 P.S.I.G.)

### NOTICE :

If the actual pressure are higher than shown, the system is most likely over-charged, and charge should be removed. If the actual pressure are lower than shown, the system is most likely under-charged, and charge should be added. The air conditioner is now ready for use.

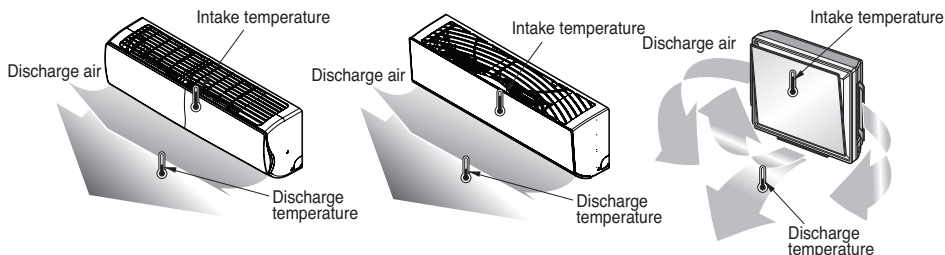

# Function

## Dip S/W Setting

If you set the Dip Switch when power is on, the change in setting is not applicable. The changing setting is enabled only when Power is reset.

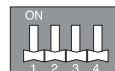

Dip Switch				Function
1	2	3	4	
				Normal Operation (No Function)
				Forced Cooling Operation
				Wiring Error Check
				Saving Power Consumption (Step 1)
				Saving Power Consumption (Step 2)
				Mode Lock (Cooling)
				Mode Lock (Heating)
				Night Quiet Mode (Step 1)
				Night Quiet Mode (Step 2)
				Mode Lock (Cooling) + Night Quiet Mode (Step 1)
				Mode Lock (Cooling) + Night Quiet Mode (Step 2)
				Mode Lock (Cooling) + Saving Power Consumption (Step 1)
				Mode Lock (Cooling) + Saving Power Consumption (Step 2)
				Mode Lock (Heating) + Saving Power Consumption (Step 1)
				Mode Lock (Heating) + Saving Power Consumption (Step 2)

**WARNING:** When you set the dip switch, you should turn off the circuit breaker or shut the power source of the product down.

**CAUTION**

- Unless the applicable dip switch is set properly, the product may not work.
- If you want to set a specific function, request that the installer sets the dip switch appropriately during installation.

18/24(1Ø) kBTu/h

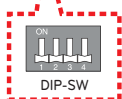
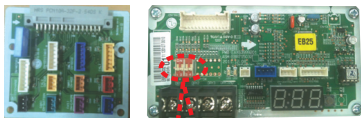

36(1Ø) kBTu/h

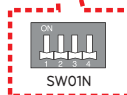
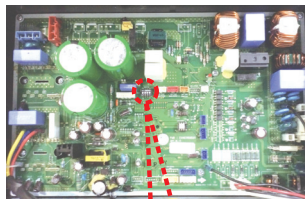

54(1Ø) kBTu/h

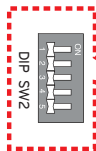
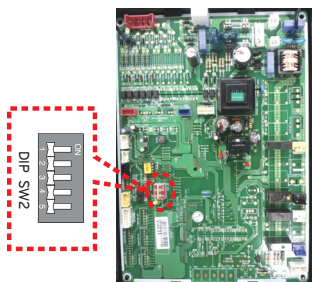

**Forced Cooling Operation**

Adding the refrigerant in winter.

**Setting Procedure**

1. Set the Dip Switch as follow after shutting the power source down.
2. Reset the power.
3. Check that the Red LED of PCB is on during work. (The indoor unit is operated by force.)
4. Add the specific amount of refrigerant.



**CAUTION**

- When the green LED of PCB is on, compressor is going to be off because of low pressure.
- You should return the Dip Switch to operate normally after finishing the operation.

## Wiring Error Check

You can check whether or not the wiring is correct.

### Setting Procedure

1. Set the Dip Switch as follow after shutting the power source down.
2. Reset the power.
3. Check that the Re and Green LED of PCB are on during work. (The indoor unit is operated by force.)
4. If the wiring is correct, the Green LED will light up.



If the wiring is wrong, display as below  
(Display only wrong connection.)

- Red LED : Piping Number
- Green LED : Wiring Number (Room)

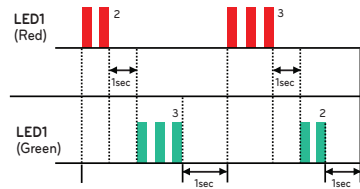

Example)

If the Red LED blinks twice and the Green LED blinks 3 times, 2nd pipe is connected to 3rd room.

5. You should return the Dip Switch to operate normally after finishing wiring error check.



### CAUTION

- If Indoor unit doesn't communicate to outdoor Unit, function could not be operated correctly.
- Only the wrong wiring connection is displayed. You should change connection correctly to operate the product.
- If Outdoor and Indoor temperature is too low in winter, the wiring error check function will not be operated.  
(Red LED is lighting)

## Saving Power Consumption

Saving Power Consumption operation is the function which enables efficient operation by lowering the maximum power consumption value.

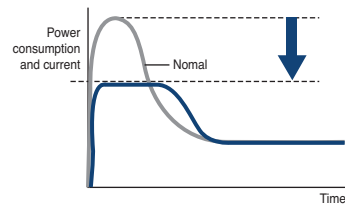

### Setting Procedure

1. Set the Dip Switch as follow after shutting the power source down.
2. Reset the power.



Step 1



Step 2

### Saving Power Consumption Current level.

Phase	1Ø		
Model	18/24k	36k	54k
Step1(A)	9	13	26
Step2(A)	8	11	22

### Saving Power Consumption with Mode Lock.



Saving Power Consumption (step 1)  
+ Mode Lock (Cooling)



Saving Power Consumption (step 1)  
+ Mode Lock (Heating)



Saving Power Consumption (step 2)  
+ Mode Lock (Cooling)



Saving Power Consumption (step 2)  
+ Mode Lock (Heating)

## Night Quiet Mode

Night Quiet Mode operation lowers the noise level of the outdoor unit by changing the comp frequency and fan speed. This function is operated all night long.

### Setting Procedure

1. Set the Dip Switch as follow after shutting the power source down.



Step 1



Step 2

\* Noise level :Step 1 > Step 2

2. Reset the power.

### Night Quiet Mode with Mode Lock.



Mode Lock (Cooling)  
+ Night Quiet Mode (step 1)



Mode Lock (Cooling)  
+ Night Quiet Mode (step 2)



### CAUTION

- If comp frequency and fan speed are down, the cooling capacity may decrease accordingly.
- This function is only available for Cooling Mode.
- If you want to stop the Night Quiet Mode, Change the Dip Switch.
- If operating indoor unit is set by the fan speed “Power”, Night Quiet Mode will be stopped until fan speed “Power” is changed.

## Mode Lock

### Setting Procedure

1. Set the Dip Switch as follow after shutting the power source down.



Only Cooling Mode



Only Heating Mode

2. Reset the power.

### Mode Lock with Night Quiet Mode



Mode Lock (Cooling)  
+ Night Quiet Mode  
(step 1)



Mode Lock (Cooling)  
+ Night Quiet Mode  
(step 2)

### Saving Power Consumption with Mode Lock.



Mode Lock (Cooling)  
+ Saving Power  
Consumption (step 1)



Mode Lock (Heating)  
+ Saving Power  
Consumption (step 1)



Mode Lock (Cooling)  
+ Saving Power  
Consumption (step 2)



Mode Lock (Heating)  
+ Saving Power  
Consumption (step 2)

## PCB Display(18/24k Model Only)

It is useful to check the cycle data without LGMV.

### Operating Method

Whenever you push the Tact Switch, the cycle information will be shown as below.

※ After 1page is displayed, subsequently 2page is displayed.

Tact S/W	Item	Display		
		Example	1page	2page
1 time	Low Pressure	890kpa	'LP'	' 89'
2 time	Hi Pressure	2900kpa	'HP'	'290'
3 time	Discharge Temp.	85°C	'DS'	' 85'
4 time	Cond Out Temp.	-10°C	'CS'	'-10'
5 time	Suction Temp.	-10°C	'SS'	'-10'
6 time	ODU Air Temp.	-10°C	'AS'	'-10'
7 time	Current	15A	'A'	' 15'
8 time	Voltage	230V	'V'	'230'
9 time	Comp Hz	100Hz	'F'	'100'
10 time	DC Link Voltage	230V	'dc'	'230'



**WARNING : When you push the Tact Switch, use the material non-conducting electricity.**

# Combination indoor units

The indoor units connectable to the outdoor unit are shown below

Category	Chassis	Model names							Outdoor Unit Capacity (Btu/h class)				
		Capacity, kW(kBtu/h Class)							18k	24k	36k	54k	
		2.1(7)	2.6 (9)	3.5 (12)	4.2(15)	5.3 (18)	7.03 (24)	10.6 (36)	Connectable	Combination			
Wall mounted	SB	AMNW07GDBL1 [LMN077HVT]	AMNW09GDBL1 [LMN097HVT]	AMNW12GDBL1 [LMN127HVT]	AMNW15GDBL1 [LMN157HVT]				0	0	0	0	
	SC					AMNW18GDCL1 [LMN187HVT]	AMNW24GDCL1 [LMN247HVT]		18K(O)	0	0	0	
ART COOL Mirror	SB		AMNW09GDBR1 [LMAN097HVT]	AMNW12GDBR1 [LMAN127HVT]					0	0	0	0	
	SC					AMNW18GDCR1 [LMAN187HVT]			0	0	0	0	
ART COOL Gallery	SF		AMNW09GAF11 [LMAN097HVP]	AMNW12GAF11 [LMAN127HVP]					0	0	0	0	
Ceiling cassette	4-way	TR	AMNW07GTRA0 [LMCN077HV]	AMNW09GTRA0 [LMCN097HV]	AMNW12GTRA0 [LMCN125HV]				0	0	0	0	
		TQ					AMNW18GTQA0 [LMCN185HV]			0	0	0	0
Ceiling concealed duct	Low static pressure (Slim)	L1		AMNW09GL1A0 [LMDN096HV]						0	0	0	0
		L2			AMNW12GL2A0 [LMDN126HV]		AMNW18GL2A0 [LMDN186HV]			0	0	0	0
	High Static pressure	BG					AMNW24GBGA0 [LMHN240HV]	AMNW36GBGA0 [LMHN360HV]		24K(O)	0	0	
Vertical AHU	NJ					AMNW24GNJA0 [LMVN240HV]	AMNW36GNJA0 [LMVN360HV]		24K(O)	0	0	0	

**NOTICE** : 1. The total capacity(in Btu/h unit) of connected indoor unit models represents the total sum of the figures expressed in the indoor model name.

2. Combinations in which the total capacity of the connected indoor units exceeds the capacity of the outdoor unit will reduce the capacity of each indoor unit below the rated capacity during simultaneous operation. Therefore, if circumstances allows, combine indoor units within the capacity of the outdoor unit





US	1. Please call the installing contractor of your product, as warranty service will be provided by them. 2. If you have service issues that have not been addressed by the contractor, please call 1-888-865-3026.
CANADA	Service call Number # : (888) LG Canada, (888) 542-2623