

Date: _____

For: File Resubmit

PO No.: _____

 Approval Other _____

Architect: _____

GC: _____

Engr: _____

Mech: _____

Rep: _____

(Company)

(Project Manager)

PMBD3630**3-Port Branch Distribution Unit (BD Unit)****Performance:**

Max Nominal Port Capacity Btu/h (each port)	24,000
Max Nominal Unit Capacity Btu/h (sum of ports)	72,000
Power Input (W)	24

Electrical:

Power Supply (V ¹ /Hz/∅)	208-230/60/1
Rated Amps (A)	0.12

Piping:**Piping Connection to Outdoor Unit:**

Liquid Line (in, OD)	3/8
Vapor Line (in, OD)	3/4

Piping Connection to Indoor Unit:

Liquid Line (in, OD)	1/4 (Qty 3)
Vapor Line (in, OD)	3/8 (Qty 3)

Standard Features:

- Distributes refrigerant to indoor units
- Internal components are insulated
- Flare joints provided for easy installation
- Compact design

Operating Range:

Operating Range (°F DB)	0-150
-------------------------	-------

Unit Data:

Net Weight (lbs)	15
Shipping Weight (lbs)	17

Notes:

1. Acceptable operating voltage: 187V-253V.
2. All power/communication cable to be minimum 16 AWG from the outdoor unit to the BD unit and 18 AWG from the BD unit to the indoor unit.
3. All power/communication cable to be 4-conductor, stranded, shielded and must comply with applicable local and national code.
4. Piping lengths:
 - Maximum height difference between BD unit and indoor units - 32.8 ft
 - Maximum height difference between BD unit and BD unit - 49.2 ft.
 - Maximum piping length between BD unit and indoor units - 49.2 ft
5. The BD unit should be installed inside of a building.
6. Must follow installation instructions in the applicable LG installation manual.
7. Power wiring cable size must comply with the applicable local and national code.

PMBD3630

3-Port Branch Distribution Unit (BD Unit)



Tag #:

Date:

PO No.:

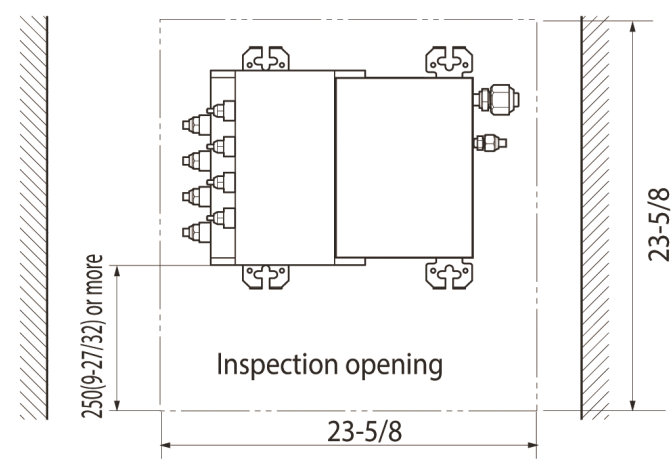
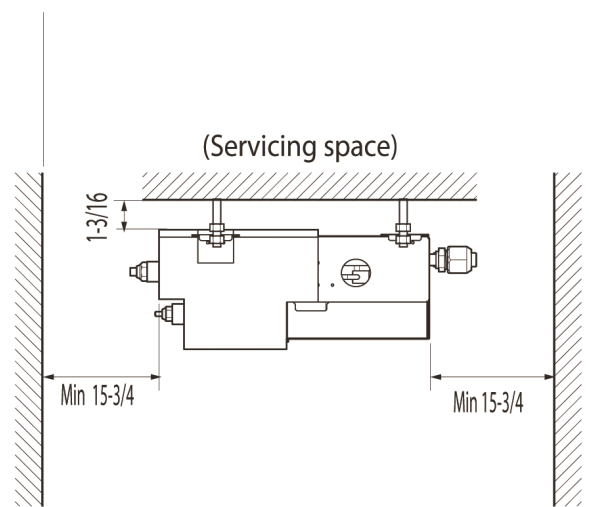
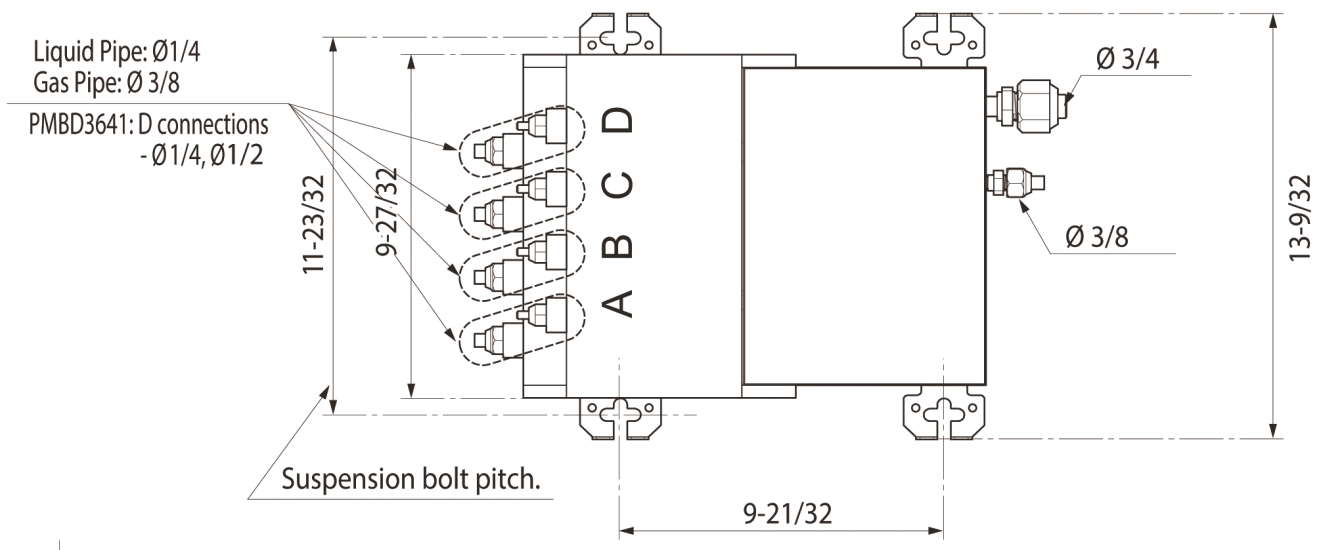
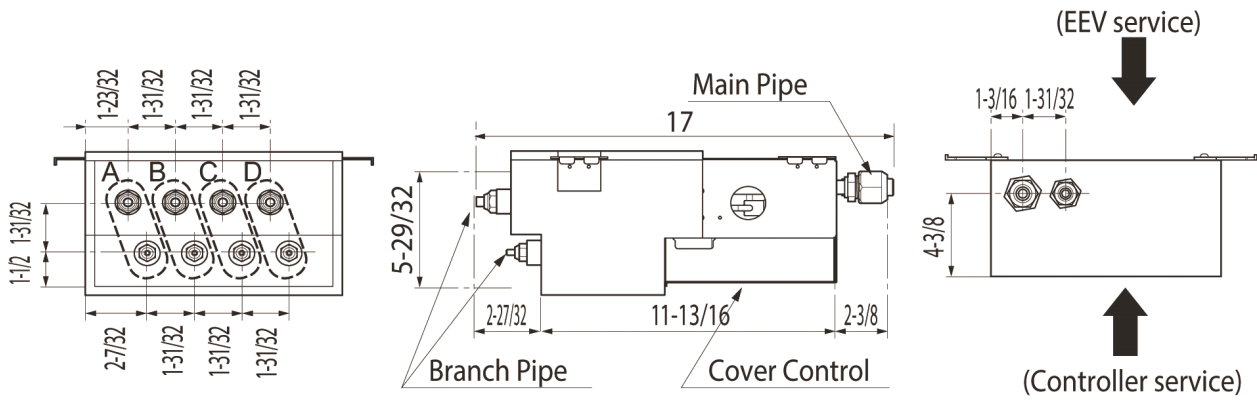

Notes

1. For PMBD3620 unit, ports A and B are available.
2. For PMBD3630 unit, ports A, B and C are available.
3. For PMBD3640 and PMBD3641 units, ports A, B, C and D are available.

Unit : inch

Job Name/Location:

Tag #:

Date:

For:	File	Resubmit
	Approval	Other_____

PO No.:

Architect: _____ GC: _____

Engr: _____ Mech: _____

Rep: _____
(Company) (Project Manager)



LMQN150HV
Multi F Low Wall Console Indoor Unit
15,000 Btu/h

Performance:

Nominal Cooling Capacity (Btu/h)	15,710
Nominal Heating Capacity (Btu/h)	17,070

Cooling Nominal Test Conditions:
Indoor: 80°F DB / 67°F WB
Outdoor: 95°F DB / 75°F WB

Heating Nominal Test Conditions:
Indoor: 70°F DB / 60°F WB
Outdoor: 47°F DB / 43°F WB

Electrical:

Power Supply (V)/Hz/Ø	208-230/60/1
Rated Amps (A)	0.7

Piping:

Installed Liquid Pipe (in., O.D.)	1/4
Installed Vapor Pipe (in., O.D.)	1/2
Liquid Connection (in., O.D.)	1/4
Vapor Connection (in., O.D.)	1/2
Drain (in., O.D. / I.D.)	27/32, 5/8
Temperature Sensor	Thermistor

Controls Features:

- Auto swing (up & down)
- 24-Hour on/off timer
- Auto operation
- Auto restart
- Chaos wind
- Inverter (variable speed fan)
- Jet cool/Jet heat
- Washable, anti-bacterial filter
- Sleep mode
- Condensate sensor connection
- Compatible with accessory Wi-Fi module

Included Accessories:

- Wireless Remote Controller — AKB75735410

Optional Accessories:

- MultiSITE™ CRC1 - PREMTBVC0
- MultiSITE CRC1+ - PREMTBVC1
- Dry Contact for Thermostat- PDRYCB320
- Simple Remote Controller - PREMTCC00U
- Premium Remote Controller - PREMTA000
- Remote Temperature Button Sensor - ZRTBS01
- Simple Dry Contact (1 contact, 24 VAC external power) - PDRYCB100
- Dry Contact for Economizer - PDRYCB400
- Auxiliary Heater Kit - PRARH1
- Wi-Fi Module - PWFMD200

Entering Mixed Air:

Cooling (°F DB)	57 ~ 77
Heating (°F WB)	59 ~ 81

Unit Data:

Refrigerant Type	R410A
Refrigerant Control	EEV
Sound Pressure (H/M/L) (±3 dB[A]) ²	44/39/35
Primary Filter	Washable Pre-filter
Net Weight (lbs.)	35.7
Shipping Weight (lbs.)	41.7

Fan:

Type	Turbo
Quantity	1
Motor/Drive	Brushless Digitally Controlled/Direct
Air Flow (Max/H/M/L) (CFM)	388 / 357 / 304 / 254

Notes:

1. Acceptable operating voltage: 187V-253V.
2. Sound Pressure levels are tested in an anechoic chamber under ISO Standard 3745.
3. See Engineering Manual for sensible and latent capacities.
4. All communication / connection (power) cable from the outdoor unit to the indoor unit is field supplied and must be a minimum of four-conductor, 14 AWG, stranded, shielded or unshielded (if shielded, it must be grounded to the chassis of the outdoor unit only), and must comply with applicable local and national codes.
5. Power wiring cable size must comply with the applicable local and national code.
6. The indoor unit comes with a dry helium charge.
7. Corresponding refrigerant piping length is in accordance with standard length of each outdoor unit and the level difference is 0 ft. All capacities are net with a combination ratio between 95 - 105%.
8. Must follow installation instructions in the applicable LG installation manual.
9. Includes a 3/8" to 1/2" socket adapter for the vapor line.



Job Name/Location: _____

LMQN150HV
Multi F Low Wall Console Indoor Unit
15,000 Btu/h



Tag No.: _____

Date: _____

PO No.: _____

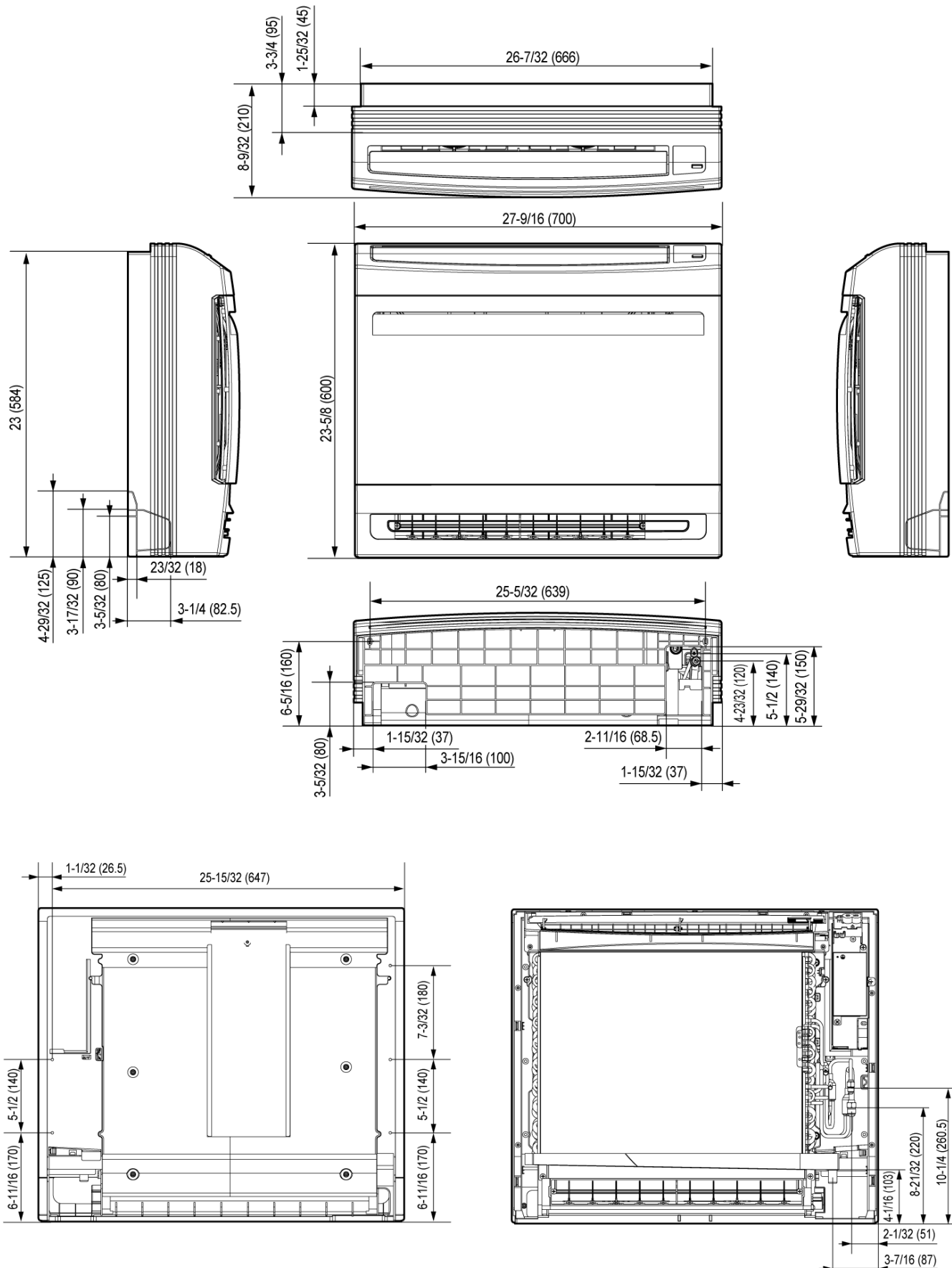

Job Name/Location:

Tag No:

Date:

For:	File	Resubmit
	Approval	Other

PO No.:

Architect: GC:

Engr: Mech:

Rep: (Company) (Project Manager)

LMU421HHV
Multi F MAX with LGRED° Outdoor Unit
3.5 Ton Heat Pump



Performance:

Cooling Capacity (Min.-Rated-Max., Btu/h)	10,800-42,000-53,000
Heating Capacity (Min.-Rated-Max., Btu/h)	12,420-48,000-54,500
Max. Heating Capacity at 17°F (Btu/h)	53,330
Max. Heating Capacity at 5°F (Btu/h)	48,450
Max. Heating Capacity at -4°F (Btu/h)	42,670
Max. Heating Capacity at -13°F (Btu/h)	37,640
Cooling COP @95°F (Rated)	4.05
Heating COP @47°F (Rated)	3.80

Cooling Nominal Test Conditions: Indoor: 80°F DB / 67°F WB Outdoor: 95°F DB / 75°F WB
 Heating Nominal Test Conditions: Indoor: 70°F DB / 60°F WB Outdoor: 47°F DB / 43°F WB

Operating Range:

Cooling (°F DB)	14 to 118
Heating (°F WB)	-13 to +64

Unit Data:

Refrigerant Type	R410A
Refrigerant Control	EEV
Sound Pressure (Cool / Heat) ±1 dB(A) ⁶	54 / 56
Net / Shipping Weight (lbs.)	218 / 243
Heat Exchanger Coating	Gold Fin™
Minimum No. of Indoor Units	2
Maximum No. of Indoor Units	6

Electrical:

Power Supply (V/Hz/Ø) ¹	208-230V, 60, 1
MOP (A)	40
MCA (A)	32.7
Cooling Rated Amps (A)	28.4
Heating Rated Amps (A)	28.4
Compressor (A)	22.0
Fan Motor (A)	1.6 x 2
Locked Rotor Amps (A)	22

MOP - Maximum Overcurrent Protection MCA - Minimum Circuit Ampacity

Compressor:

Type	R1 Scroll
Quantity	1
Oil / Type	FVC68D

Fan:

Type	Propeller
Quantity	2
Motor / Drive	Brushless Digitally Controlled/Direct
Max. Airflow Rate (CFM)	2,119 x 2

Piping:

Refrigerant Charge (lbs.)	11.46
Liquid Line Connection (in., O.D.)	Ø3/8 x 1
Vapor Line Connection (in., O.D.)	Ø3/4 x 1
Maximum Total Piping ² (ft.)	475.7
Min. / Max. ODU to IDU Piping ³ (ft.)	32.8 / 229.6
Piping Length ⁴ (no add'l refrigerant, ft.)	180.4
Maximum Elevation between ODU and IDU (ft.)	98.4
Maximum Elevation between IDU and IDU (ft.)	49.2

ODU = Outdoor Unit IDU = Indoor Unit

Features:

- R1 Scroll (Variable Speed) Compressor
- Auto operation
- Auto restart
- Self diagnosis
- Defrost / Deicing
- Low ambient cooling down to 14°F
- Soft start
- Restart delay (three [3] minutes)
- Factory installed Drain Pan Heater

Optional Accessories:

- PI-485 - PMNFP14A1
- AC Smart 5 - PACS5A000
- ACP 5 - PACP5A000
- MultiSITE™ Comm. Mgr. - PBACNBTR0A
- Power Distribution Indicator (PDI) Premium - PQNUD1S41
- Mobile LGMV - PLGMVW100
- Low Ambient Wind Baffle (Cooling Operation Down to -4°F) - ZLABGP04A x2

Required⁵ Accessories:

- 2 Port BD Unit - PMBD3620
- 3 Port BD Unit - PMBD3630
- 4 Port BD Unit - PMBD3640
- 4 Port BD Unit - PMBD3641

Notes:

1. Acceptable operating voltage: 187V - 253V.
2. Piping lengths are equivalent.
3. 180.4 ft. of Main Piping + 49.2 ft. of Branch Piping.
4. 49.2 ft. of Main Piping + 131.2 of Branch Piping.
5. At least one branch distribution (BD) unit is required for system operation; a maximum of two can be installed per ODU with the use of a Y-branch accessory (PMBL5620).
6. Sound pressure levels are tested in an anechoic chamber under ISO Std. 3745.
7. All power / communication cable to be minimum 14 AWG from the ODU to the BD unit, and 14 AWG from the BD unit to the IDU.
8. All power / communication cable to be 4-conductor, stranded, shielded or unshielded, and must comply with applicable local and national codes. If shielded, the wire must be grounded to the chassis at the ODU only.
9. Power wiring size must comply with the applicable local and national codes.
10. See the Engineering Manual Capacity Tables for ODU sensible and latent capacities.
11. See the Engineering Manual Combination Tables for allocation of ODU rated capacity to each connected IDU when all are calling for full capacity. Allocation percentages should be applied to ODU capacity at design conditions.
12. This data is rated 0 ft. above sea level, with 0 ft. level difference between ODU and IDUs, and the following refrigerant pipe lengths:
 LMU361HHV: 16.4 ft. Main + (16.4 ft. Branch x 5) = 98.4 ft.
 LMU421HHV: 16.4 ft. Main + (16.4 ft. Branch x 6) = 114.8 ft.
 LMU480HHV: 16.4 ft. Main + (16.4 ft. Branch x 8) = 147.6 ft.
 All capacities are net with a combination ratio between 95 - 105%.
13. Must follow installation instructions in the applicable LG installation manual.
14. See the Engineering Manual Capacity Tables for ODU capacity at design conditions.



For a complete list of available accessories, contact your LG representative.

For continual product development, LG reserves the right to change specifications without notice.

© LG Electronics U.S.A., Inc., Englewood Cliffs, NJ. All rights reserved. "LG Life's Good" is a registered trademark of LG Corp. /www.lghvac.com

SB_MultiF_MAX_LGRED_LMU421HHV_2021_10_18_113447

LMU421HHV
Multi F MAX with LGRED® Outdoor Unit
3.5 Ton Heat Pump



Tag No.: _____

Date: _____

PO No.: _____

[Unit: inch]

Chassis code : U60A-B

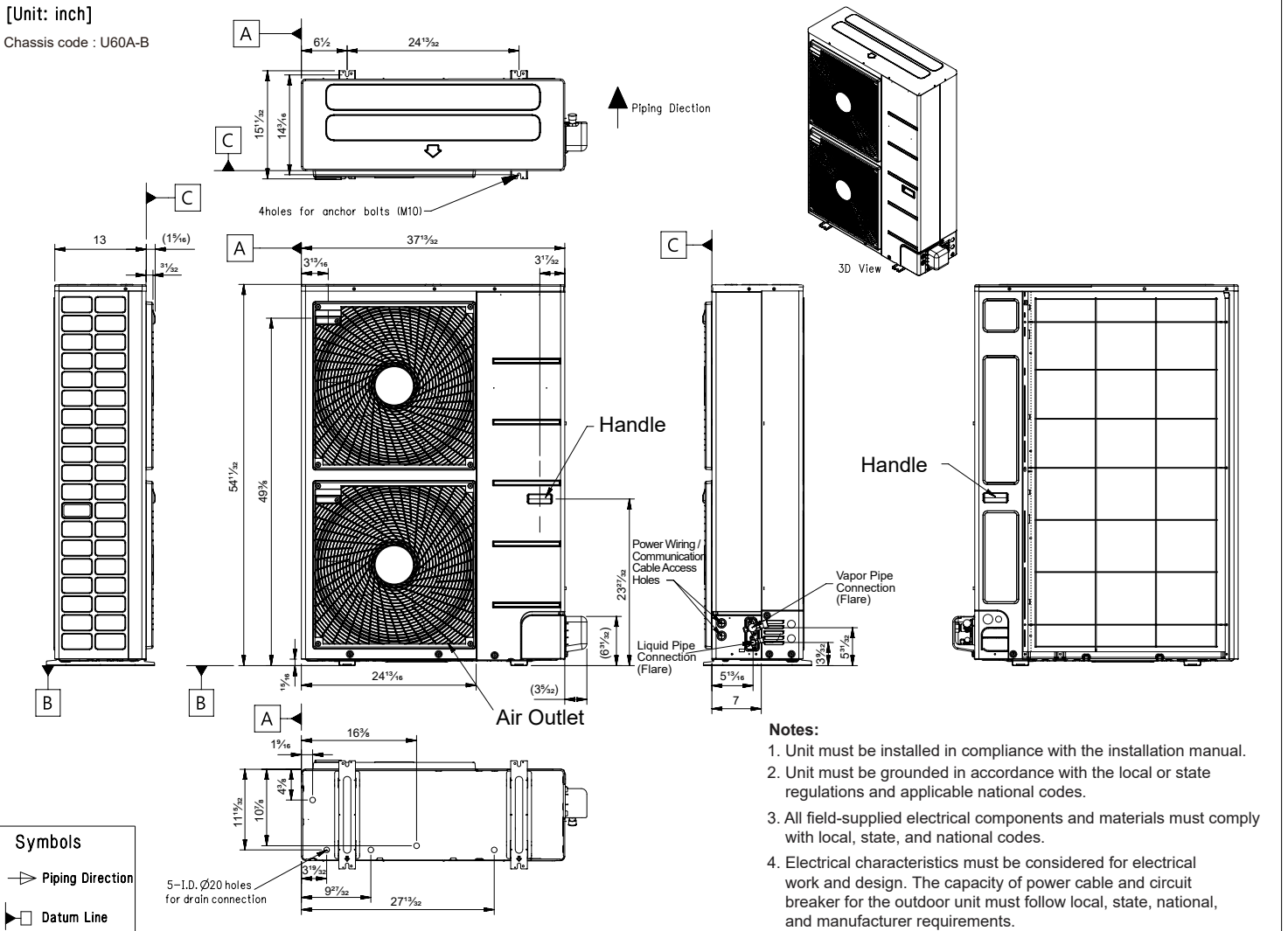

Notes:

1. Unit must be installed in compliance with the installation manual.
2. Unit must be grounded in accordance with the local or state regulations and applicable national codes.
3. All field-supplied electrical components and materials must comply with local, state, and national codes.
4. Electrical characteristics must be considered for electrical work and design. The capacity of power cable and circuit breaker for the outdoor unit must follow local, state, national, and manufacturer requirements.

Job Name/Location: _____

LMU421HHV
Multi F MAX with LGRED® Outdoor Unit
3.5 Ton Heat Pump



Tag No.: _____

Date: _____

PO No.: _____

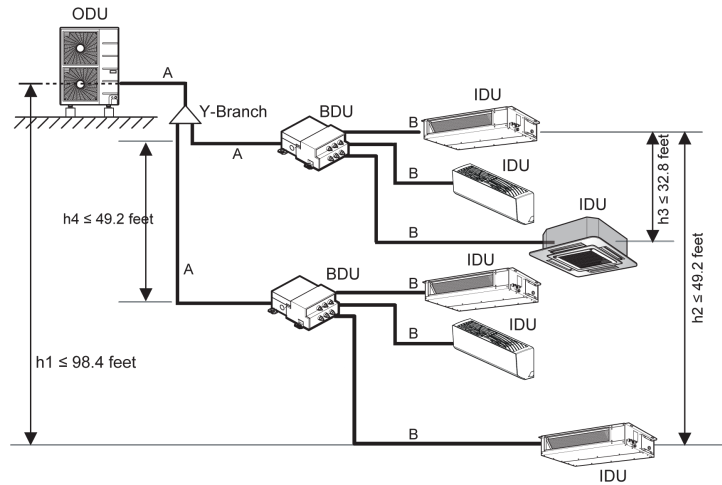

Example: LMU421HHV outdoor unit with six (6) indoor units and two (2) branch distribution units connected.
 ODU: Outdoor Unit.
 IDU: Indoor Unit.
 BDU: Branch Distribution Unit(s).
 A: Main Pipe.
 B: Branch Pipe (Branch Distribution Unit[s] to Indoor Unit[s]).

Multi F MAX with LGRED Outdoor Unit Refrigerant Piping System Limitations.

Pipe Length (ELF = Equivalent Length of pipe in Feet)	Total piping length ($\Sigma A + \Sigma B$)	≤475.7 feet	
	Main pipe (Outdoor Unit to Branch Distribution Units: A)	Minimum for Each (A) Piping Segment	16.4 feet
		Maximum (ΣA)	≤180.4 feet
	Total branch piping length (ΣB)	≤295.3 feet	
Elevation Differential (All Elevation Limitations are Measured in Actual Feet)	Branch pipe (Branch Distribution Units to Indoor Units: B)	Minimum	16.4 feet
		Maximum	≤49.2 feet
	If outdoor unit is above or below indoor unit (h1)		≤98.4 feet
	Between the farthest two indoor units (h2)		≤49.2 feet
Between branch distribution unit and farthest connected indoor unit(s) (h3)		≤32.8 feet	
Between branch distribution units (h4)		≤49.2 feet	

Installing the Unit

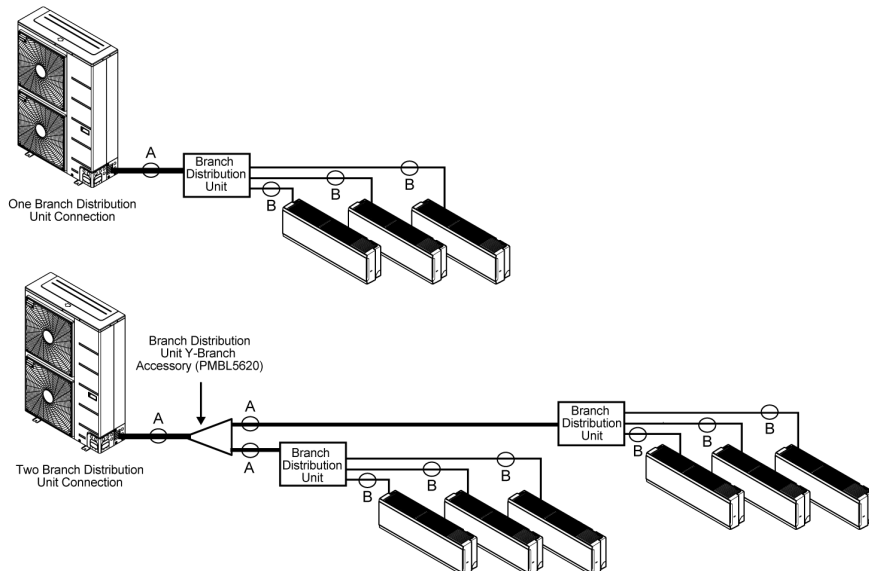

Multi F MAX with LGRED Piping Sizes.

Piping	Main Pipe A (inch)	Branch Pipe B
Liquid	Ø3/8	Depends on the size of the indoor unit piping.
Vapor	Ø3/4	

Job Name/Location:

Tag #:

Date:

For:	File	Resubmit
	Approval	Other_____

PO No.:

Architect: _____ GC: _____

Engr: _____ Mech: _____

Rep: _____
(Company) (Project Manager)

LQ120HV4 Single Zone Low Wall Console

Outdoor Unit (ODU) - LUU127HV, Indoor Unit (IDU) - LQN120HV4



Performance:

Cooling:

Cooling (Min~Rated~Max, Btu/h)	4,500 ~ 10,200 ~ 13,460
SEER2	20.8
EER2	12.6

SEER - Seasonal Energy Efficiency Ratio EER - Energy Efficiency Ratio

Heating:

Heating (Min~Rated~Max, Btu/h)	5,970 ~ 13,000 ~ 15,000
HSPF2	10.2

HSPF - Heating Seasonal Performance Factor

Cooling Nominal Test Conditions: Heating Nominal Test Conditions:
 Indoor: 80°F DB / 67°F WB Indoor: 70°F DB / 60°F WB
 Outdoor: 95°F DB / 75°F WB Outdoor: 47°F DB / 43°F WB

Electrical:

Power Supply ¹ (V/Hz/Ø)	208-230/60/1
------------------------------------	--------------

Outdoor Unit:

MOP (A)	15
MCA (A)	12.3
Cooling Rated Amps (A)	9.95
Heating Rated Amps (A)	9.95
Compressor(A)	9.0
Fan Motor (IDU + ODU) (A)	0.7 + 0.25
Cooling Power Input (kW)	0.4 ~ 0.81 ~ 1.35
Heating Power Input (kW)	0.55 ~ 1.25 ~ 1.58

MOP - Maximum Overcurrent Protection MCA - Minimum Circuit Ampacity

Piping:

Liquid Line (in., O.D.)	1/4
Vapor Line (in., O.D.)	3/8
Additional Refrigerant (oz./ft.)	0.22
Max. Pipe Length ² (ft.)	66
Piping Length (no add'l refriger., ft.)	24.6
Max. Elevation (ft.)	49

Features:

- Hot start
- Inverter (variable speed fan)
- Auto restart
- Control lock
- Group control
- Timer (on/off)
- Sleep Mode
- Optional Wi-Fi Control

Included Accessories:

Wireless Remote Controller — AKB75735410

Optional Accessories:

- | | |
|--|---|
| <input type="checkbox"/> MultiSITE™ CRC1 - PREMTBVC0 | <input type="checkbox"/> Drain Pan Heater - PQSH1202 |
| <input type="checkbox"/> MultiSITE CRC1+ - PREMTBVC1 | <input type="checkbox"/> Dry Contact for Thermostat - PDRYCB320 |
| <input type="checkbox"/> MultiSITE Comm. Mgr. - PBACNBTR0A | <input type="checkbox"/> Simple Dry Contact (1 Contact, 24VAC external power) - PDRYCB100 |
| <input type="checkbox"/> AC Smart 5 - PACS5A000 | <input type="checkbox"/> Dry Contact for Economizer - PDRYCB400 |
| <input type="checkbox"/> Simple Controller - PREMTCC00U | <input type="checkbox"/> Premium Remote Controller - PREMTA000 |
| <input type="checkbox"/> Wi-Fi module with cable - PWFMD200 | <input type="checkbox"/> PI-485 - PMNFP14A1 |
| <input type="checkbox"/> Low Ambient Wind Baffle (Cooling operation to -4°F) ZLABGP01A | |

Operating Range:

Outdoor Unit:

Cooling (°F DB)	0 to 118
Heating (°F WB)	-4 to 64

Indoor Unit:

Cooling (°F WB)	57 to 77
Heating (°F DB)	59 to 81

System Data:

Refrigerant Type	R410A
Refrigerant Control	EEV
Refrigerant Charge (lbs.)	2.425
ODU Sound Pressure Max (Cool / Heat) ±3 dB(A) ³	49 / 52
IDU Sound Pressure (H/M/L) ±3 dB(A) ³	39 / 32 / 27
ODU Net / Shipping Weight (lbs.)	74.5 / 80
IDU Net / Shipping Weight (lbs.)	35.9 / 42.5
Heat Exchanger Coating	GoldFin™

Fan:

ODU Type	Propeller
IDU Type	Sirocco
Fan Speeds (Fan/Cool/Heat)	4 / 5 / 5
Fan Quantity (ODU + IDU)	1 + 1
Motor/Drive	Brushless Digitally Controlled/Direct
ODU Air Circulation (CFM)	988
Air Flow (Max/H/M/L) (CFM)	353 / 318 / 244 / 184
Dehumidification Rate (pts/hr)	2.5

Notes:

1. Acceptable operating voltage: 187V-253V.
2. Piping lengths are equivalent.
3. Sound Pressure levels are tested in an anechoic chamber under ISO Standard 3745.
4. All communication / connection (power) cable from the outdoor unit to the indoor unit is field supplied and is to be minimum four-conductor, 14 AWG, stranded, shielded or unshielded (if shielded, it must be grounded to the chassis of the outdoor unit only), and must comply with applicable local and national codes.
5. See Engineering Manual for sensible and latent capacities.
6. Power wiring cable size must comply with the applicable local and national code.
7. The indoor unit comes with a dry helium charge.
8. This data is rated 0 ft. above sea level, with 24.6 ft. of refrigerant line and a 0 ft. level difference between outdoor and indoor units.
9. Must follow installation instructions in the applicable LG installation manual.



For a complete list of available accessories, contact your LG representative.

For continual product development, LG reserves the right to change specifications without notice.

© LG Electronics U.S.A., Inc., Englewood Cliffs, NJ. All rights reserved. "LG Life's Good" is a registered trademark of LG Corp. /www.lghvac.com

SB_SZ_Console_LQ120HV4_2022_12_13_100734

Job Name/Location: _____

LQ120HV4

Single Zone Low Wall Console

Outdoor Unit (ODU) - LUU127HV, Indoor Unit (IDU) - LQN120HV4



Tag No.: _____

Date: _____

PO No.: _____

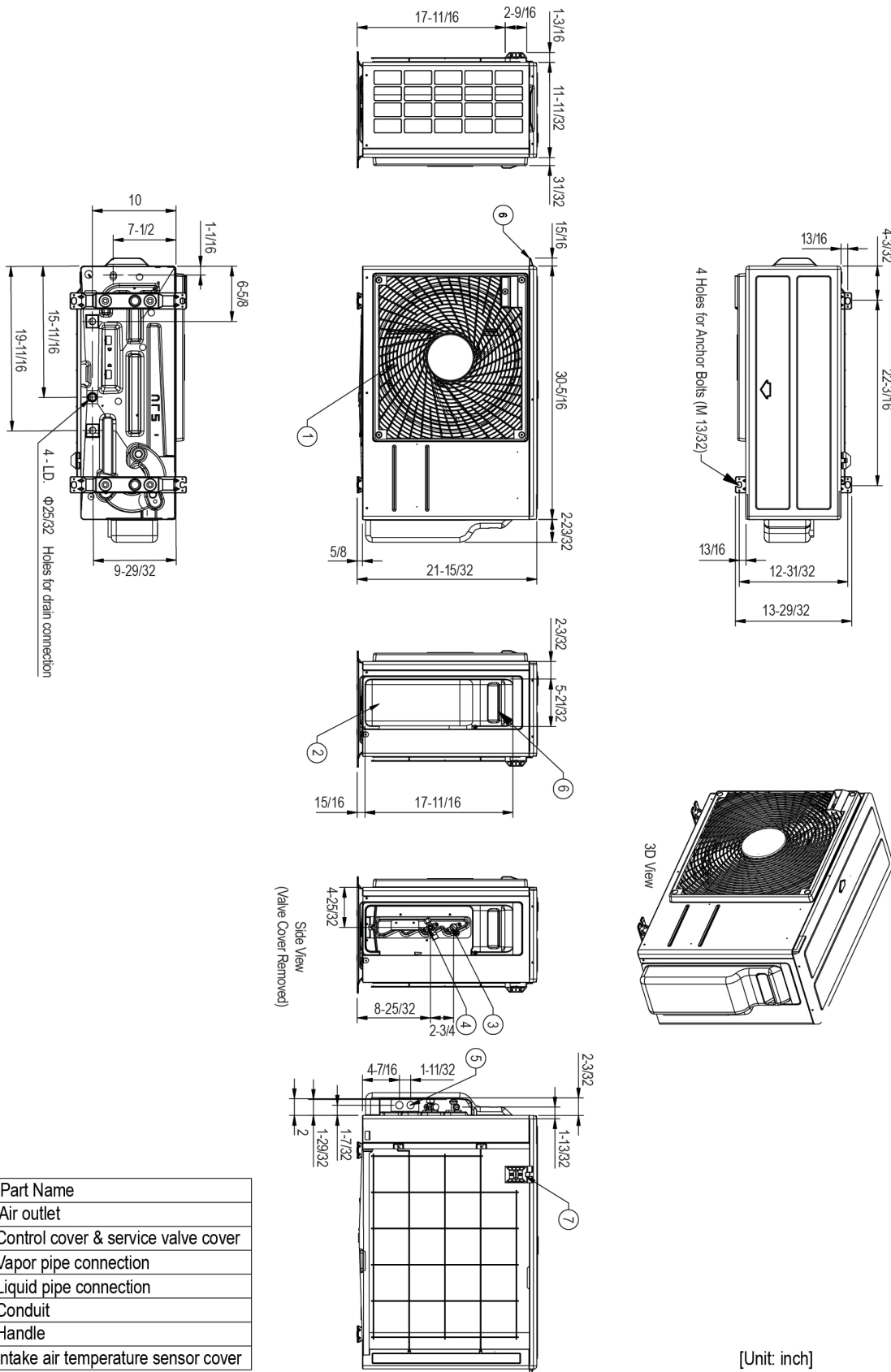

[Unit: inch]

No.	Part Name
1	Air outlet
2	Control cover & service valve cover
3	Vapor pipe connection
4	Liquid pipe connection
5	Conduit
6	Handle
7	Intake air temperature sensor cover

Job Name/Location: _____

LQ120HV4

Single Zone Low Wall Console

Outdoor Unit (ODU) - LUU127HV, Indoor Unit (IDU) - LQN120HV4



Tag No.: _____

Date: _____

PO No.: _____

