



# MULTI F MULTI F MAX WITH LGR<sup>ED</sup>

## HEAT PUMP OUTDOOR UNIT INSTALLATION MANUAL

**Multi-Zone Heat Pump Systems  
1.5 to 3.5 Tons**

Dual-, Tri-, and Quad-Zone  
Multi F



Up to Six Zones  
Multi F MAX

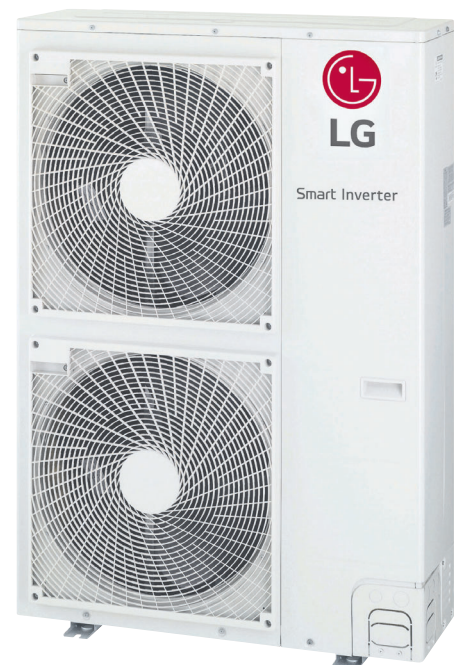

## **PROPRIETARY DATA NOTICE**

**This document, as well as all reports, illustrations, data, information, and other materials are the property of LG Electronics U.S.A., Inc., and are disclosed by LG Electronics U.S.A., Inc. only in confidence.**

**⊘ Do not throw away, destroy, or lose this manual.  
Please read carefully and store in a safe place for future reference.  
Content familiarity is required for proper installation.**

The instructions included in this manual must be followed to prevent product malfunction, property damage, injury, or death to the user or other people. Incorrect operation due to ignoring any instructions will cause harm or damage. The level of seriousness is classified by the symbols described by the summary list of safety precautions on page 4.

**For more technical materials such as submittals, catalogs, engineering, owner's, best practices, building ventilation guide, and service manuals, visit [www.lghvac.com](http://www.lghvac.com).**

For continual product development, LG Electronics U.S.A., Inc. reserves the right to change specifications without notice.

© LG Electronics U.S.A., Inc.

---







---

<b>Safety Instructions</b> .....	<b>4-7</b>
<b>Nomenclature</b> .....	<b>8</b>
<b>General Data</b> .....	<b>9-16</b>
<b>Installation</b> .....	<b>17-30</b>
<i>Transporting / Lifting</i> .....	17
<i>Placement Considerations</i> .....	18-27
<i>Mounting / Anchoring</i> .....	28-30
<b>General Refrigerant Piping System Information</b> .....	<b>31-45</b>
<i>LG Air Conditioner Technical Solution (LATS)</i> .....	31-32
<i>Refrigerant Safety Standards / Device</i>	
<i>Connection Limitations</i> .....	33-34
<i>Selecting Copper Piping</i> .....	35
<i>Copper Expansion and Contraction</i> .....	36-38
<i>Piping Handling</i> .....	39
<i>Refrigerant System Engineering</i> .....	40-43
<i>Flaring and Brazing Procedures</i> .....	44-45
<b>Refrigerant Piping System Installation</b> .....	<b>46-54</b>
<b>Refrigerant Piping Insulation</b> .....	<b>55-57</b>
<b>Electrical System Installation</b> .....	<b>58-72</b>
<i>General Information</i> .....	58
<i>Connections and Specifications</i> .....	59-62
<i>Installation</i> .....	63-72
<b>Final Installation Procedures</b> .....	<b>73-88</b>
<i>Triple Leak / Pressure Test</i> .....	73-74
<i>Deep Evacuation Test</i> .....	74-75
<i>Triple Evacuation Test</i> .....	75-76
<i>Refrigerant Charge</i> .....	77-79
<i>Cautions for Refrigerant Leaks</i> .....	80-81
<i>Test Run</i> .....	82
<i>DIP Switch Settings for Optional Modes</i> .....	83-88
<b>Error Codes</b> .....	<b>89-90</b>
<b>LG Monitoring View (LGMV) Diagnostic Software</b> .....	<b>91-92</b>
<b>LG Smart Inverter Monitoring System (SIMS)</b> .....	<b>93-94</b>
<b>Maintenance Recommendations</b> .....	<b>95</b>
<b>Installation Checklists and Worksheets</b> .....	<b>96-101</b>

The instructions below must be followed to prevent product malfunction, property damage, injury or death to the user or other people. Incorrect operation due to ignoring any instructions will cause harm or damage. The level of seriousness is classified by the symbols described below.

## TABLE OF SYMBOLS

 <b>DANGER</b>	<i>This symbol indicates an imminently hazardous situation which, if not avoided, will result in death or serious injury.</i>
 <b>WARNING</b>	<i>This symbol indicates a potentially hazardous situation which, if not avoided, could result in death or serious injury.</i>
 <b>CAUTION</b>	<i>This symbol indicates a potentially hazardous situation which, if not avoided, may result in minor or moderate injury.</i>
<b>Note:</b>	<i>This symbol indicates situations that may result in equipment or property damage accidents only.</i>
	<i>This symbol indicates an action must not be completed.</i>

## Installation

### DANGER

 **Do not store or use flammable gas or combustibles near the unit.**  
*There is risk of fire, explosion, and physical injury or death.*

 **Do not supply power to the unit until all wiring and piping are completed or reconnected and checked.**  
*There is risk of physical injury or death due to electric shock.*

### WARNING

 **Do not install or remove the unit by yourself (end user). Ask the dealer or a trained technician to install the unit.**  
*Improper installation by the user will result in fire, explosion, electric shock, physical injury or death.*

**For replacement of an installed unit, always contact an LG trained service provider.**  
*There is risk of fire, electric shock, explosion, and physical injury or death.*

**Wear protective gloves when handling equipment. Sharp edges will cause personal injury.**

 **Do not change the settings of the protection devices.**  
*If the protection devices have been bypassed or is forced to operate improperly, or parts other than those specified by LG are used, there is risk of fire, electric shock, explosion, and physical injury or death.*

**Replace all control box and panel covers.**  
*If cover panels are not installed securely, dust, water and animals will enter the outdoor unit, causing fire, electric shock, and physical injury or death.*

**Always check for system refrigerant leaks after the unit has been installed or serviced.**  
*Exposure to high concentration levels of refrigerant gas will lead to illness or death.*

**Periodically check that the outdoor frame is not damaged.**  
*There is a risk of explosion, physical injury, or death.*

**If the air conditioner is installed in a small space, take measures to prevent the refrigerant concentration from exceeding safety limits in the event of a refrigerant leak.**  
*Consult the latest edition of ASHRAE (American Society of Heating, Refrigerating, and Air Conditioning Engineers) Standard 15. If the refrigerant leaks and safety limits are exceeded, it could result in personal injuries or death from oxygen depletion.*

**The branch distribution (BD) unit must be installed indoors;**  
 **do not install the BD unit in a highly humid environment.**  
*There is risk of physical injury or death due to electric shock.*

### **Dispose the packing materials safely.**

- *Packing materials, such as nails and other metal or wooden parts, will cause puncture wounds or other injuries.*
- *Tear apart and throw away plastic packaging bags so that children will not play with them and risk suffocation and death.*

**Install the unit considering the potential for strong winds or earthquakes.**  
*Improper installation will cause the unit to fall over, resulting in physical injury or death.*

**Install the unit in a safe location where nobody can step, fall onto it, or place objects on it.**  **Do not install the unit on a defective stand.**  
*It will result in an accident that causes physical injury or death.*



---

---

## Installation, continued

### ⚠ WARNING

**Properly insulate all cold surfaces to prevent “sweating.”**

*Cold surfaces such as uninsulated piping can generate condensate that could drip, causing a slippery surface that creates a risk of slipping, falling, and personal injury.*

---

### ⚠ CAUTION

**Be very careful when transporting the product. There is a risk of the product falling and causing physical injury.**

- Use appropriate moving equipment to transport each frame; ensure the equipment is capable of supporting the weights listed.
- Some products use polypropylene bands for packaging. Ⓣ Do not use polypropylene bands to lift the unit.
- Support the outdoor unit a minimum of four points to avoid slippage from rigging apparatus.

---

## Note:

LG Electronics U.S.A., Inc., is not responsible for any piping calculations, refrigerant leaks, degradation of performance, or any other potential problems or damages as a result of interconnecting piping, their joint connections, isolation valves, introduced debris inside the piping system, or other problems caused by the interconnecting piping system.

Ⓣ Do not install the product where it is exposed directly to ocean winds.

*Sea salt in the air will cause the product to corrode. Corrosion, particularly on the condenser and evaporator fins, could cause product malfunction or inefficient operation.*

**When installing the outdoor unit in a low-lying area, or a location that is not level, use a raised concrete pad or concrete blocks to provide a solid, level foundation.**

*This prevents water damage and abnormal vibration.*

**Properly insulate all cold surfaces to prevent “sweating.”**

*Cold surfaces such as uninsulated piping can generate condensate that will drip and cause water damage to walls.*

**Always check for system refrigerant leaks after the unit has been installed or serviced.**

*Low refrigerant levels will cause product failure.*

**The branch distribution (BD) unit must be installed indoors;**

Ⓣ Do not install the BD box in a highly humid environment. *There is risk of product failure and property damage.*

Ⓣ Do not make refrigerant substitutions. Use R410A only. *If a different refrigerant is used, or air mixes with original refrigerant, the unit will malfunction and be damaged.*

Ⓣ Do not store or use flammable gas / combustibles near the unit.

*There is a risk of product failure.*

Ⓣ Do not use the product for mission critical or special purpose applications such as preserving foods, works of art, or other precision air conditioning applications. The equipment is designed to provide comfort cooling and heating. *There is risk of property damage.*

**Keep the unit upright during installation to avoid vibration or water leakage.**

**When connecting refrigerant tubing, remember to allow for pipe expansion.**

*Improper piping will cause refrigerant leaks and system malfunction.*

Ⓣ Do not install the outdoor unit or BD unit in a noise-sensitive area.

**Take appropriate actions at the end of HVAC equipment life to recover, recycle, reclaim or destroy R410A refrigerant according to applicable U.S. Environmental Protection Agency (EPA) rules.**

**Periodically check that the outdoor frame is not damaged.** *There is a risk of equipment damage.*

**Install the unit in a safe location where nobody can step on or fall onto it.** Ⓣ Do not install the unit on a defective stand. *There is a risk of unit and property damage.*

**Install the drain hose to ensure adequate drainage.** *There is a risk of water leakage and property damage.*

## Wiring

### ⚠ DANGER

**High voltage electricity is required to operate this system. Adhere to the NEC code and these instructions when wiring. Improper connections and inadequate grounding can cause accidental injury or death.**

**Always ground the unit following local, state, and NEC codes. There is risk of fire, electric shock, and physical injury or death.**

**Turn the power off at the nearest disconnect before servicing the equipment. Electrical shock can cause physical injury or death.**

**Properly size all circuit breakers or fuses. There is risk of fire, electric shock, explosion, physical injury or death.**

⊘ **Do not share the electrical circuit with other appliances. There is risk of fire, electric shock, and physical injury or death due to heat generation.**

⊘ **Do not use damaged or loose power wiring. ⊘ Do not randomly modify or extend the outdoor unit's power wiring. Ensure that the power wiring will not be pulled nor weight be placed on the power wiring during operation. There is risk of fire, electric shock, and physical injury or death.**

### ⚠ WARNING

**The information contained in this manual is intended for use by an industry-qualified, experienced, certified electrician familiar with the U.S. National Electric Code (NEC) who is equipped with the proper tools and test instruments. Failure to carefully read and follow all instructions in this manual can result in personal injury or death.**

**All electric work must be performed by a licensed electrician and conform to local building codes or, in the absence of local codes, with the National Electrical Code, and the instructions given in this manual. If the power source capacity is inadequate or the electric work is not performed properly, it will result in fire, electric shock, physical injury or death.**

**Refer to local, state, and federal codes, and use power wires of sufficient current capacity and rating. Wires that are too small will generate heat and cause a fire.**

**Secure all field wiring connections with appropriate wire strain relief. Improperly securing wires will create undue stress on equipment power lugs. Inadequate connections will generate heat, cause a fire and physical injury or death.**

**Ensure the system is connected to a dedicated power source that provides adequate power. If the power source capacity is inadequate or the electric work is not performed properly, it will result in fire, electric shock, physical injury or death.**

**Properly tighten all power connections. Loose wiring will overheat at connection points, causing a fire, physical injury or death.**

⊘ **Do not change the settings of the protection devices. If the protection devices have been bypassed or are forced to operate improperly, or parts other than those specified by LG are used, there is risk of fire, electric shock, explosion, and physical injury or death.**

## Note:

⊘ **Do not supply power to the unit until all electrical wiring, controls wiring, piping, installation, and refrigerant system evacuation are completed. System will malfunction.**

**The information contained in this manual is intended for use by an industry-qualified, experienced, certified electrician familiar with the U.S. National Electric Code (NEC) who is equipped with the proper tools and test instruments. Failure to carefully read and follow all instructions in this manual can result in equipment malfunction and / or property damage.**

## Operation

### ⚠ DANGER

⊘ Do not provide power to or operate the unit if it is flooded or submerged.

*There is risk of fire, electric shock, physical injury or death.*

**Use a dedicated breaker for this product.**

*There is risk of fire, electric shock, physical injury or death.*

⊘ Do not operate the disconnect switch with wet hands.

*There is risk of fire, electric shock, physical injury or death.*

**Periodically verify the equipment mounts have not deteriorated.**

*If the base collapses, the unit could fall and cause physical injury or death.*

Use inert (nitrogen) gas when performing leak tests or air purges. ⊘ Do not use compressed air, oxygen, or flammable gases.

*Using these substances will cause fire, explosion, and physical injury or death.*

**If refrigerant leaks out, ventilate the area before operating the unit.**

*If the unit is mounted in an enclosed, low-lying, or poorly ventilated area, and the system develops a refrigerant leak, it will cause a fire, electric shock, explosion, physical injury or death.*

### ⚠ WARNING

⊘ Do not allow water, dirt, or animals to enter the unit.

*There is risk of fire, electric shock, physical injury or death.*

⊘ Do not operate the unit with the panel(s) or protective cover(s) removed; keep fingers and clothing away from moving parts.

*The rotating, hot, cold, and high-voltage parts of the unit can cause physical injury or death.*

⊘ Do not touch the refrigerant piping during or after operation.

*It can cause burns or frostbite.*

⊘ Do not open the inlet during operation.

*There is risk of electric shock, physical injury or death.*

### ⚠ CAUTION

**To avoid physical injury, use caution when cleaning or servicing the air conditioner.**

*There is risk of electric shock, physical injury or death.*

## Note:

Clean up the site after servicing is finished, and check that no metal scraps, screws, or bits of wiring have been left inside or surrounding the unit.

⊘ Do not use the product for mission critical or special purpose applications such as preserving foods, works of art, or other precision air conditioning applications. The equipment is designed to provide comfort cooling and heating.

*Oil, steam, sulfuric smoke, etc., can significantly reduce the performance of the unit, or damage its parts.*

⊘ Do not block the inlet or outlet.

*Unit will malfunction.*

⊘ Do not allow water, dirt, or animals to enter the unit.

*There is risk of unit failure.*

⊘ Do not open the inlet during operation.

*There is risk of unit failure.*

⊘ Do not operate the unit when the panel(s) or protective cover(s) are removed.

*Non-secured covers can result in product malfunction due to dust or water in the service panel.*

**Periodically verify the equipment mounts have not deteriorated.**

*If the base collapses, the unit could fall and cause property damage or product failure.*

**Use a only soft cloth to clean the air conditioner. ⊘ Do not use wax, thinner, or strong detergents.**

*Strong cleaning products will damage the surface of the air conditioner, or will cause its appearance to deteriorate.*

# UNIT NOMENCLATURE

## Multi-Zone Systems — Indoor Units and Outdoor Units

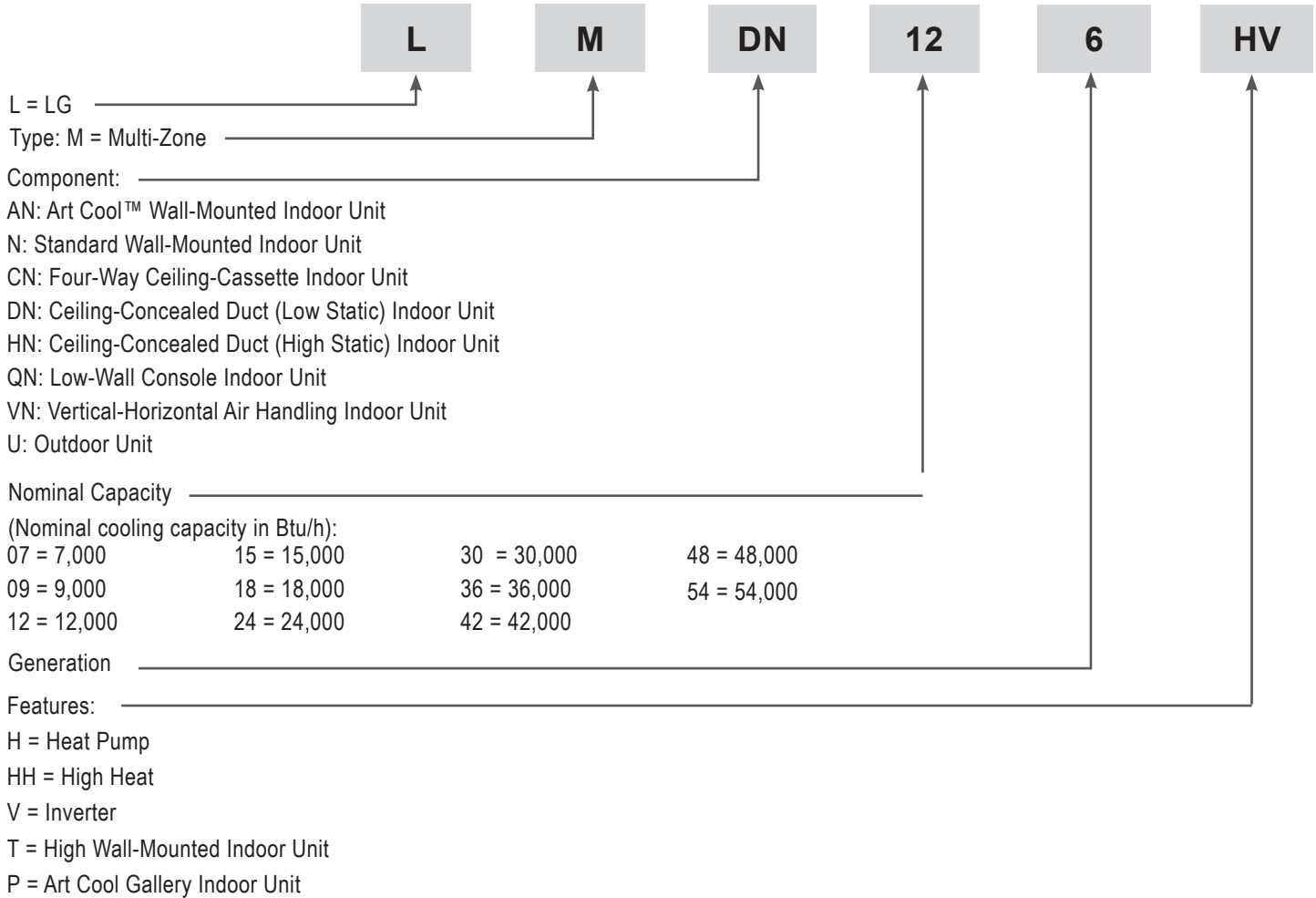

## Branch Distribution Units

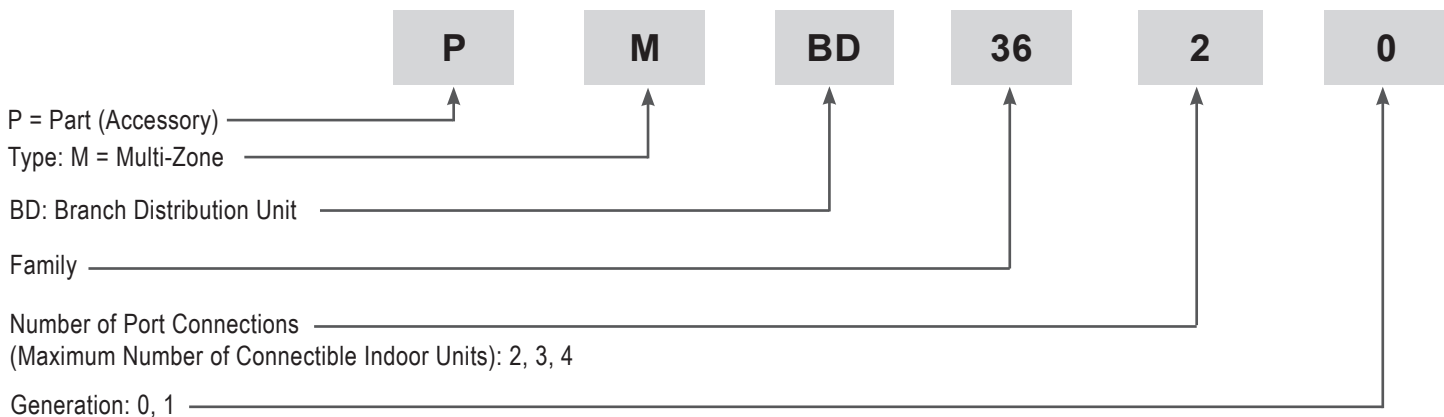

### Note:

- Voltage for all equipment is 208-230V, 60 Hz, 1-phase.
- All indoor units are compatible with wired controllers.
- All outdoor units are LGAP control network compatible with PI-485 V-net Control Integration Board (PMNFP14A1, sold separately).
- Compatible single zone IDU nomenclature is listed in the Single Zone Wall-Mounted IDU Engineering Manual.

Table 1: Multi F with LGRED Outdoor Unit Specifications.

Model Number	LMU180HHV	LMU240HHV	LMU300HHV
<b>Capacity</b>			
Nominal	18,000	24,000	30,000
Cooling (Btu/h) (Min.~Rated~ Max.) <sup>1</sup>	8,400 ~ 18,000 ~ 19,980	8,400 ~ 24,000 ~ 30,000	8,400 ~ 28,400 ~ 34,080
Cooling Power Input (kW) (Min.~Rated~ Max.)	0.88 ~ 1.33 ~ 1.87	0.94 ~ 1.78 ~ 2.49	0.95 ~ 2.27 ~ 3.18
Cooling Running Current (A) (Min.~Rated~ Max.)	4.0 ~ 6.0 ~ 8.5	4.3 ~ 8.1 ~ 11.3	4.3 ~ 10.3 ~ 14.5
Heating (Btu/h) (Min.~Rated~ Max.) <sup>1</sup>	10,248~22,000~24,000	10,248~26,000~31,200	10,248~28,600~34,320
Heating Power Input (kW) (Min.~Rated~ Max.)	1.25 ~ 2.22 ~ 3.11	1.26 ~ 2.12 ~ 2.96	1.30 ~ 2.33 ~ 3.26
Heating Running Current (A) (Min.~Rated~ Max.)	5.7 ~ 10.1 ~ 14.1	5.7 ~ 9.6 ~ 13.5	5.9 ~ 10.6 ~ 14.8
<b>Operating Range</b>			
Cooling (°F DB) <sup>2</sup>	14 to +118		
Heating (°F WB)	-13 to +75		
<b>Compressor</b>			
Inverter Quantity	Twin Rotary x 1		
Oil / Type	FVC68D		
<b>Fan (Side Discharge)</b>			
Type	Propeller		
Motor Output (W) x Qty.	124.2 x 1		
Motor / Drive	Brushless Digitally Controlled / Direct		
Maximum Air Flow Rate (ft. <sup>3</sup> / min.)	2,295		
<b>Unit Data</b>			
Refrigerant Type	R410A		
Refrigerant Control / Location	Electronic Expansion Valve / Outdoor Unit		
Min. Number Indoor Units/System <sup>3</sup>	2	2	2
Max. Number Indoor Units/System <sup>3</sup>	2	3	4
Maximum Allowable Total Indoor Unit Connected Capacity (Btu/h)	24,000	33,000	40,000
Sound Pressure ±3 dB(A) (Cooling / Heating) dB(A) <sup>4</sup>	50 / 54	52 / 55	52 / 55
Dimensions (W x H x D [inch])	37-13/32 x 32-27/32 x 13		
Net Unit Weight (lbs.)	147.7	152.1	152.1
Power Supply (V, Phase, Hz)	208 / 230V, 1, 60		
Communication / Connection (Power) Cable (No. x AWG) <sup>5,6</sup>	4C x 14		
<b>Heat Exchanger</b>			
Material and Fin Coating	Copper Tube/Aluminum Fin and GoldFin™ / Hydrophilic		
Rows/Columns / Fins per inch x Qty.	(3 x 38 x 16) x 1		
<b>Piping</b>			
Liquid Line Connection (in., O.D.) x Qty.	Ø1/4 x 2	Ø1/4 x 3	Ø1/4 x 4
Vapor Line Connection (in., O.D.) x Qty.	Ø3/8 x 2	Ø3/8 x 3	Ø3/8 x 4
Factory Charge oz. of R410A	98.8	112.8	
Additional Charging Volume (oz. / ft.)	0.22		
<b>Piping Lengths</b>			
Maximum Total Piping (ft.) <sup>7</sup>	164	246.1	
Maximum Outdoor Unit to Indoor Unit Piping (ft.)	82.0		
Piping Length (No Additional Refrigerant [ft.])	49.2	73.8	98.4
Maximum Elevation between Outdoor Unit and Indoor Unit (ft.)	49.2		
Maximum Elevation between Indoor Unit and Indoor Unit (ft.)	24.6		

<sup>1</sup>Rated capacity applied with non-ducted indoor units, and is rated 0 ft. above sea level with 25 ft. of refrigerant line per indoor unit and a 0 ft. level difference between outdoor and indoor units. All capacities are net with a combination ratio between 95 – 105%.

Rated cooling capacity obtained with air entering the indoor unit at 80°F dry bulb (DB) and 67°F wet bulb (WB) and outdoor ambient conditions of 95°F dry bulb (DB) and 75°F wet bulb (WB).

Rated heating capacity obtained with air entering the indoor unit at 70°F dry bulb (DB) and 60°F wet bulb (WB) and outdoor ambient conditions of 47°F dry bulb (DB) and 43°F wet bulb (WB).

<sup>2</sup>Cooling range with Low Ambient Wind Baffle Kit (sold separately) is -4°F to +118°F.

<sup>3</sup>At least two indoor units must be connected. For allocated capacity information, see the combination tables in the "Multi F / Multi F MAX with LGRED Combination Data Manual" on www.lghvac.com. For performance data, see "Multi F / Multi F MAX with LGRED Performance Data Manual" on www.lghvac.com.

<sup>4</sup>Sound pressure levels are tested in an anechoic chamber under ISO Standard 3745 and are the same in both cooling and heating mode. These values can increase due to ambient conditions during operation.

<sup>5</sup>Power wiring to the outdoor unit is field supplied, solid or stranded, and must comply with all the applicable local and national codes. For detailed information, please refer to electrical characteristics on page 10.

<sup>6</sup>Communication / connection (power) cable from the outdoor units to the indoor units must be a minimum of 14 AWG, 4-conductor stranded, shielded or unshielded (if shielded, it must be grounded to the chassis of the outdoor unit only), and must comply with applicable local and national codes. For detailed electrical information, please refer to electric characteristics on page 10.

<sup>7</sup>Piping lengths are equivalent.

# GENERAL DATA

## Multi F with LGRED Outdoor Unit Electrical Data



Table 2: Multi F with LGRED Electrical Data.

Nominal Tons	Unit Model No.	Hertz	Voltage	Voltage Range (Min. to Max.)	MCA	MOP	RFA	Compressor Quantity	Compressor Motor RLA	Outdoor Unit Fan Motor		Indoor Unit Fan Motor
										kW	FLA	FLA
1.5	LMU180HHV	60	208 - 230	187 - 253	18.6	30	25	1	13	0.12	0.73	1.6
2	LMU240HHV				19	30	25	1	13	0.12	0.73	2.0
2.5	LMU300HHV				19.4	30	25	1	13	0.12	0.73	2.4

Voltage tolerance is  $\pm 10\%$ .

Maximum allowable voltage unbalance is 2%.

MCA = Minimum Circuit Ampacity.

Maximum Overcurrent Protection (MOP) is calculated as follows: (Largest motor FLA x 2.25) + (Sum of other motor FLA) rounded down to the nearest standard fuse size.

RFA = Recommended Fuse Amps.

RLA = Rated Load Amps.

FLA = Full Load Amps.

Indoor Fan Motor (FLA) is based on the max. combination of IDUs.

The maximum combination for each outdoor unit is:

- 18,000 ODU (LMU180HHV): 12,000 IDU x 2

- 24,000 ODU (LMU240HHV): 12,000 IDU x 2 + 9,000 IDU x 1

- 30,000 ODU (LMU300HHV): 12,000 IDU x 3

Figure 1: LMU180HHV, LMU240HHV, and LMU300HHV External Dimensions.

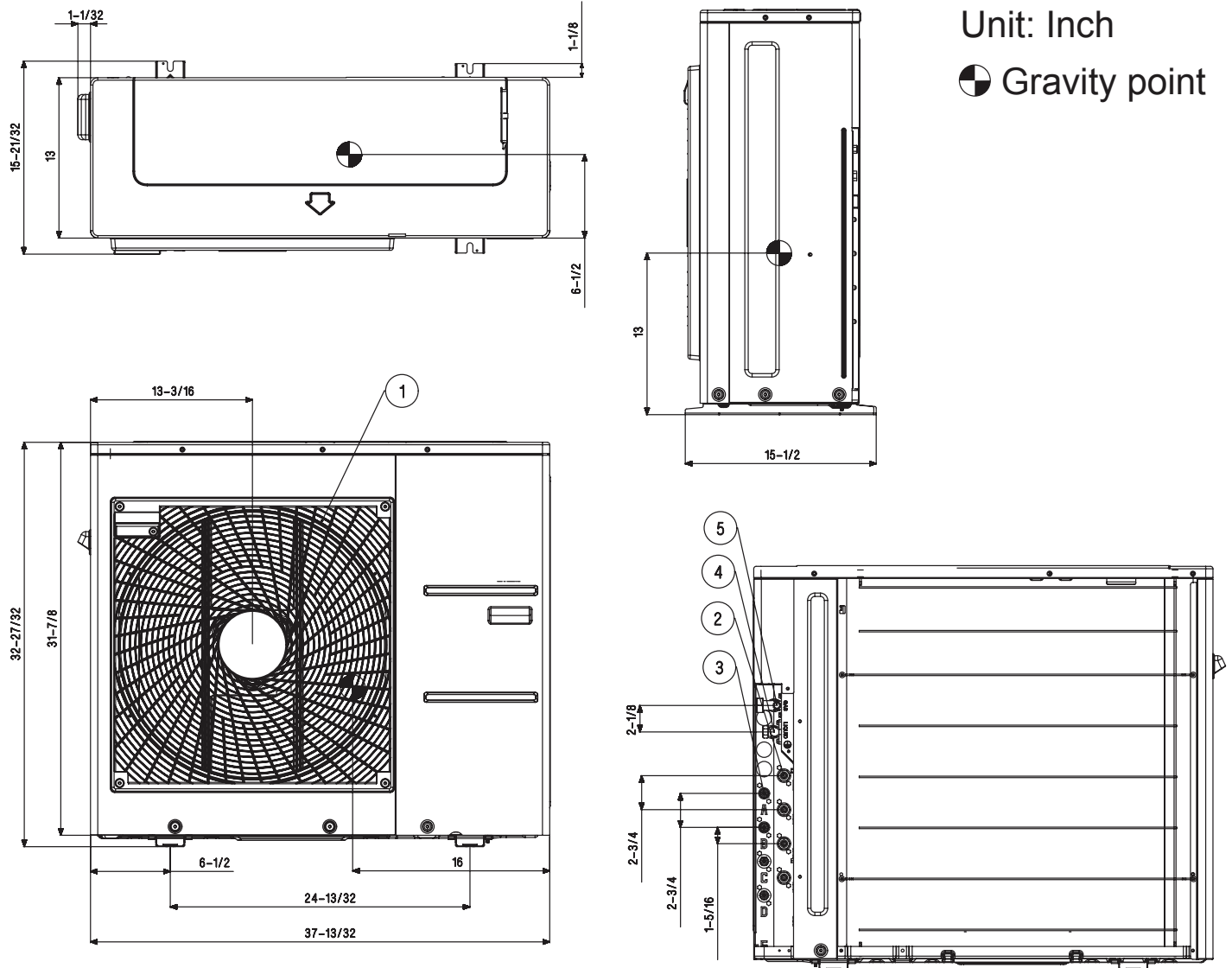

No.	Part Name
1	Air discharge grille
2	Gas pipe connection
3	Liquid pipe connection
4	Main service valve (Liquid)
5	Main service valve (Gas)



# GENERAL DATA

MULTI F WITH LGRED<sup>®</sup>  
MULTI F MAX

## Multi F MAX with LGRED Outdoor Unit Specifications

Table 3: Multi F MAX with LGRED Outdoor Unit Specifications.

Model Number	LMU360HHV	LMU420HHV
<b>Capacity</b>		
Nominal	36,000	42,000
Cooling (Btu/h) (Min.~Rated~ Max.) <sup>1</sup>	11,700~36,000~46,733	11,700~42,000~53,897
Cooling Power Input (kW) (Min.~Rated~ Max.)	0.72 ~ 2.40 ~ 3.75	0.72 ~ 3.00 ~ 4.34
Cooling Running Current (A) (Min.~Rated~ Max.)	3.9 ~ 13.0 ~ 20.4	3.9 ~ 16.3 ~ 23.6
Heating (Btu/h) (Min.~Rated~ Max.) <sup>1</sup>	13,455~41,000~50,200	13,455~45,000~55,256
Heating Power Input (kW) (Min.~Rated~ Max.)	0.96 ~ 2.93 ~ 3.94	0.96 ~ 3.30 ~ 4.48
Heating Running Current (A) (Min.~Rated~ Max.)	5.2 ~ 15.9 ~ 21.4	5.2 ~ 17.9 ~ 24.3
<b>Operating Range</b>		
Cooling (°F DB) <sup>2</sup>	14 to +118	
Heating (°F WB)	-13 to +75	
<b>Compressor</b>		
Inverter Quantity	Twin Rotary x 1	
Oil / Type	FVC68D	
<b>Fan (Side Discharge)</b>		
Type	Propeller	
Motor Output (W) x Qty.	124.2 x 2	
Motor / Drive	Brushless Digitally Controlled / Direct	
Maximum Air Flow Rate (ft. <sup>3</sup> / min.)	2,119 x 2	
<b>Unit Data</b>		
Refrigerant Type	R410A	
Refrigerant Control / Location	Electronic Expansion Valve / Outdoor Unit	
Min. Number Indoor Units / System <sup>3</sup>	2	
Max. Number Indoor Units / System <sup>3</sup>	5	6
Max. Number of Branch Distribution Units	2	
Maximum Allowable Total Indoor Unit Connected Capacity (Btu/h)	48,000	56,000
Sound Pressure ±3 dB(A) (Cooling / Heating) dB(A) <sup>4</sup>	54 / 57	
Dimensions (W x H x D [inch])	37-13/32 x 54-11/32 x 13	
Net Unit Weight (lbs.)	222.7	
Power Supply (V, Phase, Hz)	208 / 230V, 1, 60	
Communication / Connection (Power) Cable from ODU & BDU / BDU & IDU (No. X AWG) <sup>5,6</sup>	4C x 14 / 4C x 14	
<b>Heat Exchanger</b>		
Material and Fin Coating	Copper Tube/Aluminum Fin and GoldFin™ / Hydrophilic	
Rows/Columns / Fins per inch x Qty.	(2 x 32 x 14) x 2, (1 x 32 x 14) x 2	
<b>Piping</b>		
Liquid Line Connection (in., O.D.) x Qty.	Ø3/8 x 1	Ø3/8 x 1
Vapor Line Connection (in., O.D.) x Qty.	Ø3/4 x 1	Ø3/4 x 1
Factory Charge oz. of R410A	197.5	
Additional Charging Volume (oz. / ft.)	Main Pipe	0.54
	Branch Pipe	0.22
<b>Piping Lengths</b>		
Maximum Total Piping (ft.) <sup>7</sup>	475.7	
Maximum Piping Length (No Additional Refrigerant [ft.])	16.4 ft. of Main Piping + 131.2 ft. of Branch Piping	
Maximum Main Pipe Length (Outdoor Unit to Branch Distribution Unit [ft.])	180.4	
Total Branch Piping (Branch Distribution Unit to all Indoor Units [ft.])	295.3	
Maximum Branch Pipe Length (Length between each BDU & IDU [ft.])	49.2	
Maximum Outdoor Unit to Indoor Unit Pipe Length (ft.)	82.0	
Maximum Elevation between Outdoor Unit and Indoor Unit (ft.)	98.4	
Maximum Elevation between Indoor Unit and Indoor Unit (ft.)	49.2	
Maximum Elevation between Branch Distribution Unit and Indoor Unit (ft.)	32.8	
Maximum Elevation between Branch Distribution Unit and Branch Distribution Unit (ft.)	49.2	

<sup>1</sup>Rated capacity applied with non-ducted indoor units, and is rated 0 ft. above sea level with a 0 ft. level difference between outdoor and indoor units. All capacities are net with a combination ratio between 95 – 105%.

Rated cooling capacity obtained with air entering the indoor unit at 80°F dry bulb (DB) and 67°F wet bulb (WB) and outdoor ambient conditions of 95°F dry bulb (DB) and 75°F wet bulb (WB).  
Rated heating capacity obtained with air entering the indoor unit at 70°F dry bulb (DB) and 60°F wet bulb (WB) and outdoor ambient conditions of 47°F dry bulb (DB) and 43°F wet bulb (WB).

<sup>2</sup>Cooling range with Low Ambient Wind Baffle Kit (sold separately) is -4°F to +118°F.

<sup>3</sup>At least one Branch Distribution Unit is required for system operation; a maximum of two can be installed per outdoor unit with use of Y-branch accessory (PMBL5620). At least two indoor units must be connected. For allocated capacity information, see the combination tables in the "Multi F / Multi F MAX with LGRED Combination Data Manual" on www.lghvac.com. For performance data, see "Multi F / Multi F MAX with LGRED Performance Data Manual" on www.lghvac.com.

<sup>4</sup>Sound pressure levels are tested in an anechoic chamber under ISO Standard 3745. These values can increase due to ambient conditions during operation.

<sup>5</sup>Power wiring to the outdoor unit is field supplied, solid or stranded, and must comply with the applicable local and national codes. For detailed information, please refer to electrical characteristics on page 13.

<sup>6</sup>Communications / connection (power) cable must be a minimum of 14 AWG, 4-conductor from the outdoor unit to the BD unit, and 14 AWG, 4-conductor from the BD unit to the indoor unit, stranded, shielded or unshielded (if shielded, it must be grounded to the chassis of the outdoor unit only), and must comply with applicable local and national codes. For detailed electrical information, please refer to electric characteristics on page 13.

<sup>7</sup>Piping lengths are equivalent.

MULTI F / MULTI F MAX with LGRED Outdoor Unit Installation Manual

Table 4: Multi F MAX with LGRED Electrical Data.

Nominal Tons	Unit Model No.	Hertz	Voltage	Voltage Range (Min. to Max.)	MCA	MOP	Compressor Quantity	Compressor Motor RLA	Outdoor Unit Fan Motor(s)		Indoor Unit Fan Motor
									kW x Quantity	FLA x Quantity	FLA
3.0	LMU360HHV	60	208 - 230	187 - 253	30.2	45	1	20.4	0.12 x 2	0.73 x 2	3.2
3.5	LMU420HHV				30.2	45	1	20.4	0.12 x 2	0.73 x 2	3.2

Voltage tolerance is ±10%.

Maximum allowable voltage unbalance is 2%.

MCA = Minimum Circuit Ampacity.

Maximum Overcurrent Protection (MOP) is calculated as follows: (Largest motor FLA x 2.25) + (Sum of other motor FLA) rounded down to the nearest standard fuse size.

RLA = Rated Load Amps.

FLA = Full Load Amps.

Indoor Fan Motor (FLA) is based on the max. combination of IDUs.

# GENERAL DATA

## Multi F with LGRED Outdoor Unit Dimensions

MULTI F WITH LGRED<sup>®</sup>  
MULTI F MAX

Figure 2: LMU360HHV and LMU420HHV External Dimensions.

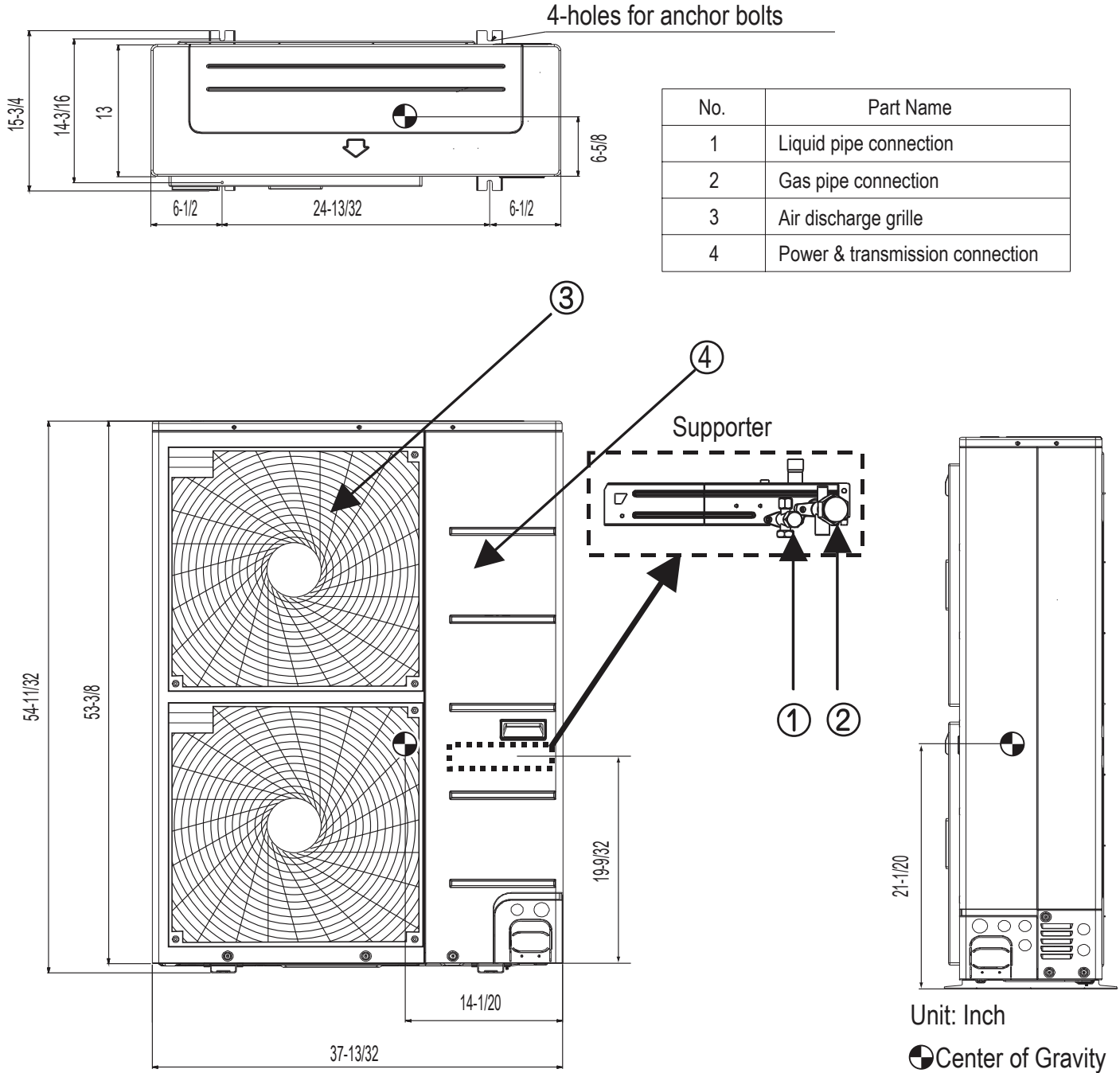

Table 5: Branch Distribution Unit General Data.

Model Number	PMBD3620	PMBD3630	PMBD3640	PMBD3641
No. of Connectible Indoor Units <sup>1</sup>	1-2	1-3	1-4	1-4
Max. Nominal Capacity / Port (Btu/h) <sup>2</sup>	24,000	24,000	24,000	24,000 for A,B,C Ports; 36,000 for D Port
Max. Nominal Capacity / Branch Distribution Unit (Btu/h)	48,000	72,000	73,000	73,000
Operation Temperature Range (°F DB)	0 ~ 150	0 ~ 150	0 ~ 150	0 ~ 150
<b>Unit Data</b>				
Refrigerant Type	R410A	R410A	R410A	R410A
Power Supply V, Ø, Hz	208-230, 1, 60	208-230, 1, 60	208-230, 1, 60	208-230, 1, 60
Power Input (W)	16	24	32	32
Rated Amps (A)	0.08	0.12	0.16	0.16
Dimensions W x H x D (in.)	17-3/32 x 6-13/32 x 10-23/32	17-3/32 x 6-13/32 x 10-23/32	17-3/32 x 6-13/32 x 10-23/32	17-3/32 x 6-13/32 x 10-23/32
Net Unit Weight (lbs.)	13	14.3	15.7	15.7
Shipping Weight (lbs.)	15	17	18	18
<b>Communication / Connection (Power) Cables<sup>3</sup></b>				
From Outdoor Unit to Branch Distribution Unit (Qty. x AWG) <sup>3</sup>	4C x 14	4C x 14	4C x 14	4C x 14
From Branch Distribution Unit to Indoor Unit (Qty. x AWG) <sup>3</sup>	4C x 14	4C x 14	4C x 14	4C x 14
<b>Piping Connections</b>				
Outdoor Unit to Branch Distribution Unit	Liquid (in., OD)	Ø3/8	Ø3/8	Ø3/8
	Vapor (in., OD)	Ø3/4	Ø3/4	Ø3/4
Branch Distribution Unit to Indoor Units	Liquid (in., OD) x Qty.	Ø1/4 x 2	Ø1/4 x 3	Ø1/4 x 4
	Vapor (in., OD) x Qty.	Ø3/8 x 2	Ø3/8 x 3	Ø3/8 x 4
<b>Piping Lengths</b>				
Maximum Total System Piping (ft.) <sup>4</sup>	475.7	475.7	475.7	475.7
Maximum Main Pipe Length (Outdoor Unit to Branch Distribution Units [ft.])	180.4	180.4	180.4	180.4
Total Branch Piping (Branch Distribution Units to Indoor Units [ft.])	295.3	295.3	295.3	295.3
Maximum Branch Pipe Length Between Branch Distribution Unit and Each Indoor Unit [ft.]	49.2	49.2	49.2	49.2
Maximum Outdoor Unit to Indoor Unit Pipe Length (ft.)	229.6	229.6	229.6	229.6
Piping Length (No Additional Refrigerant [ft.]; approx. 16 ft. of Main Piping + 131 ft. of Branch Piping)	147.6	147.6	147.6	147.6
Maximum Elevation between Branch Distribution Unit and Indoor Unit (ft.)	32.8	32.8	32.8	32.8
Maximum Elevation between Branch Distribution Unit and Branch Distribution Unit (ft.)	49.2	49.2	49.2	49.2

<sup>1</sup>At least one branch distribution Unit is required for system operation; a maximum of two can be installed per outdoor unit with use of Y-branch accessory (PMBL5620) To connect only one (1) indoor unit to a branch distribution unit, the system must include another branch distribution unit with at least one (1) connected indoor unit.

<sup>2</sup>Branch distribution Unit can accommodate from one (1) indoor unit up to four (4) indoor units depending on the ports available on the branch distribution Unit.

<sup>3</sup>Communication / power (connection) cable must be a minimum of 14 AWG, 4-conductor from the outdoor unit to the branch distribution unit (Multi F MAX with LGRED systems only), and 14 AWG, 4-conductor from the branch distribution unit to the indoor unit, stranded, shielded or unshielded (if shielded, it must be grounded to the chassis of the outdoor unit only), and must comply with applicable local and national codes.

<sup>4</sup>Piping lengths are equivalent.

# GENERAL DATA

## Branch Distribution Unit Dimensions

MULTI F WITH LGRED<sup>®</sup>  
MULTI F MAX

Figure 3: PMBD3620, PMBD3630, PMBD3640, and PMBD3641 External Dimensions.

A-C (and PMBD3640 D) Connections:

Liquid Pipe  $\varnothing 1/4$   
Gas Pipe  $\varnothing 3/8$

PMBD3641 D Connections:

Liquid Pipe  $\varnothing 1/4$   
Gas Pipe  $\varnothing 1/2$

Unit: Inch

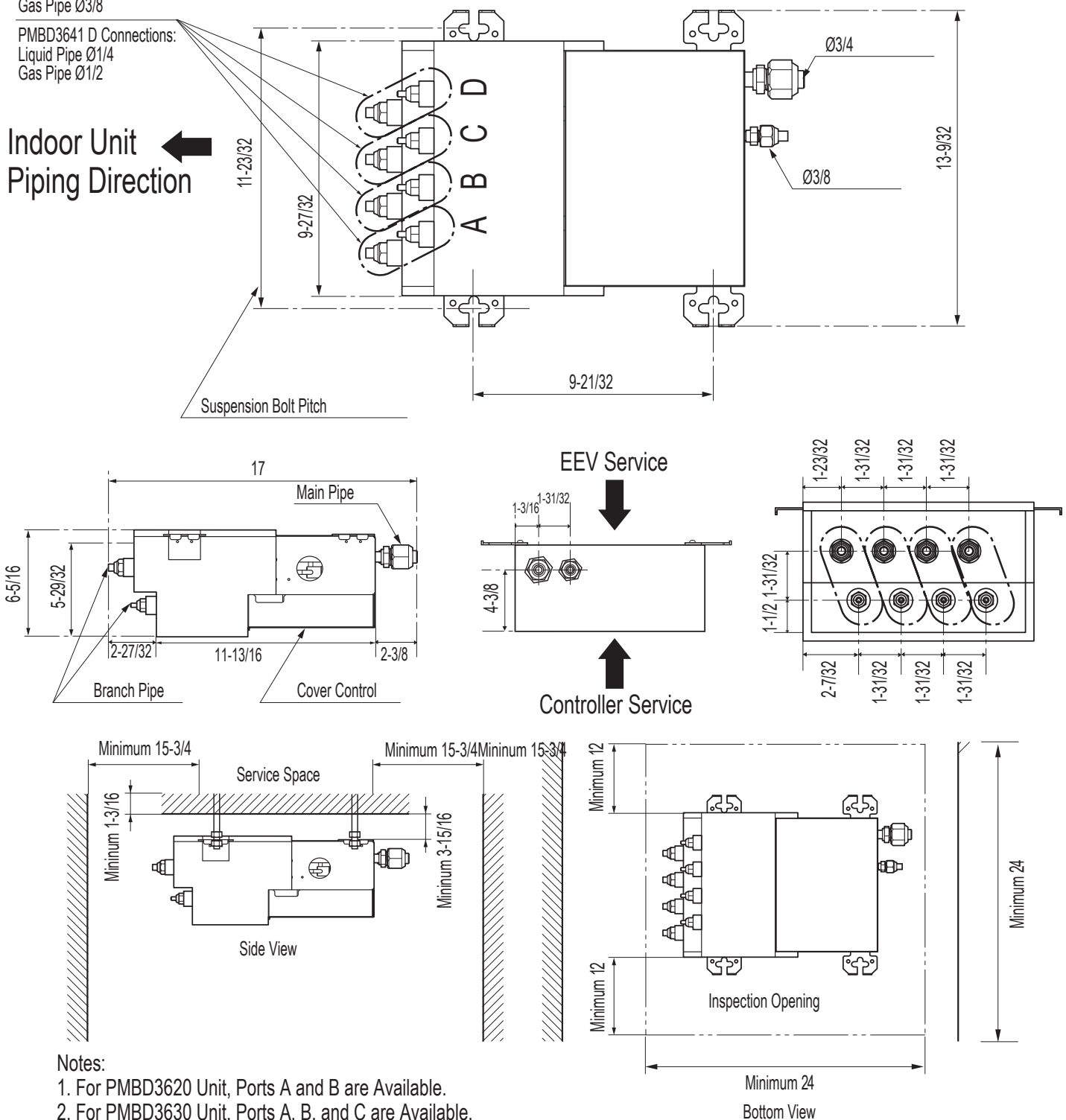

### Notes:

1. For PMBD3620 Unit, Ports A and B are Available.
2. For PMBD3630 Unit, Ports A, B, and C are Available.
3. For PMBD3640 and PMBD3641 Units, Ports A, B, C, and D are Available.

## Transporting / Lifting the Outdoor Unit

- At the time of delivery, the package must be checked for any damage (exterior and interior). Report any damage to the carrier claims agent immediately.
- When lifting the unit, use lifting straps and place properly around the unit.
- Always lift the unit using properly sized lifting straps rated to carry the unit weight.
- Ensure the straps are long enough to maintain a maximum of a 40° angle.

Table 6: Multi F / Multi F MAX with LGRED Shipping and Net Weights.

Capacity (ton)	Shipping Weight (lbs.)	Net Weight (lbs.)
1.5	163.1	147.7
2	165.3	152.1
2.5	165.3	
3	249.1	222.7
3.5	249.1	

### ⚠ WARNING

**Be very careful when transporting the product. There is a risk of the product falling and causing physical injury.**

- Use appropriate moving equipment to transport each frame; ensure the equipment is capable of supporting the weights listed above. If the equipment is not properly secured, it will result in an accident that causes physical injury or death.
- Wear protective gloves when handling equipment. Sharp edges will cause personal injury.
- Dispose the packing materials safely. Packing materials, such as nails and other metal or wooden parts, will cause puncture wounds or other injuries.
- Tear apart and throw away plastic packaging bags so that children will not play with them and risk suffocation and death.
- Use caution when using a forklift to transport an unpackaged unit. The forklift arms must pass through the openings at the bottom. ⊘ Do not drop the unit when carrying it with a forklift. There is a risk of the product falling and causing physical injury.
- Consider the unit's center of gravity before lifting. Hoist the unit with the center of gravity centered among the lifting straps. There is a risk of the product falling and causing physical injury.
- Some products include polypropylene bands around the unit for packaging. ⊘ Do not use polypropylene bands to lift the unit. There is a risk of the product falling and causing physical injury.
- Lift the outdoor unit from the base at specified locations. Support the outdoor unit at a minimum of four (4) points to avoid slippage from the rigging apparatus. There is a risk of the product falling and causing physical injury.
- If a crane is to suspend the outdoor unit, it is recommended that two (2) ropes at least twenty-three (23) feet in length be used.
- Pass the ropes under the unit. Pass the rope through the two (2) forklift slots each at the front and rear of the outdoor unit.
- To prevent damage to the outdoor unit, always lift the unit with the ropes attached at four (4) points at an angle of ≤40°.

### Note:

- Make sure the outdoor unit is in its original packaging to avoid damage during local transport.
- Handle the outdoor unit with care. Keep the outdoor unit upright to avoid damaging inside components.
- When lifting, always include padding to protect the outdoor unit from rope damage.





# PLACEMENT CONSIDERATIONS

## Selecting the Best Location for the Outdoor Unit

MULTI F WITH LGRED°  
MULTI F MAX

### Selecting the Best Location for the Outdoor Unit

#### ⚠ DANGER

-  Do not install the unit in an area where combustible gas will generate, flow, stagnate, or leak. These conditions can cause a fire, resulting in bodily injury or death.
-  Do not install the unit in a location where acidic solution and spray (sulfur) are often used as it can cause bodily injury or death.
-  Do not use the unit in environments where oil, steam, or sulfuric gas are present as it can cause bodily injury or death.

#### ⚠ CAUTION

When deciding on a location to place the outdoor unit, be sure to choose an area where run-off from defrost will not accumulate and freeze on sidewalks or driveways, which will create unsafe conditions. Properly install and insulate any drain hoses to prevent the hose from freezing, cracking, leaking, and causing unsafe conditions from frozen condensate.

#### ⚠ WARNING

Install a fence to prevent vermin from crawling into the unit or unauthorized individuals from accessing it. Vermin and unauthorized individuals will cause a fire, electric shock, physical injury or death. Follow the placement guidelines set forth in "Clearance Requirements".

#### Note:

Install a fence to prevent vermin from crawling into the unit or unauthorized individuals from accessing it. Vermin and unauthorized individuals will damage the unit. Follow the placement guidelines set forth in "Clearance Requirements".

Select a location for installing the outdoor unit that will meet the following conditions:

- Where there is enough strength to bear the weight of the unit.
- A location that allows for optimum air flow and is easily accessible for inspection, maintenance, and service.
- Where piping between the outdoor unit and indoor unit (and branch distribution unit[s], if Multi F MAX with LGRED) is within allowable limits.
- Include space for drainage to ensure condensate flows properly out of the unit when it is in heating mode.  Avoid placing the outdoor unit in a low-lying area where water could accumulate.
- If the outdoor unit is installed in a highly humid environment (near an ocean, lake, etc.), ensure that the site is well-ventilated and has a lot of natural light (Example: Install on a rooftop).

#### Do Not's

- Where it will be subjected to direct thermal radiation from other heat sources, or an area that would expose the outdoor unit to heat or steam like discharge from boiler stacks, chimneys, steam relief ports, other air conditioning units, kitchen vents, plumbing vents, and other sources of extreme temperatures.
- Where high-frequency electrical noise / electromagnetic waves will affect operation.
- Where operating sound from the unit will disturb inhabitants of surrounding buildings.
- Where the unit will be exposed to direct, strong winds.
- Where the discharge of one outdoor unit will blow into the inlet side of an adjacent unit (when installing multiple outdoor units).

### Outdoor Unit Condensate Drain Piping

Outdoor unit requires condensate drain piping. Condensate drain pipe is constructed with materials approved by local code. See pages 20 to 22 for information in reference to outdoor unit placement.

### Planning for Snow and Ice

To ensure the outdoor unit operates properly, certain measures are required in locations where there is a possibility of heavy snowfall or severe windchill or cold:

1. Prepare for severe winter wind chills and heavy snowfall, even in areas of the country where these are unusual phenomena.
2. Position the outdoor unit so that its airflow fans are not buried by direct, heavy snowfall. If snow piles up and blocks the airflow, the system will malfunction.
3. Remove any snow that has accumulated four (4) inches or more on the top of the outdoor unit.
4. In climates that will experience significant snow buildup, mount the outdoor unit on a raised, field-provided platform or stand. The raised support platform must be high enough to allow the unit to remain above possible snow drifts, and must be higher than the maximum anticipated snowfall for the location.
5. Design the mounting base to prevent snow accumulation on the platform in front or back of the unit frame.
6. Provide a field fabricated snow protection hood to keep snow and ice and/or drifting snow from accumulating on the coil surfaces.
7. To prevent snow and heavy rain from entering the outdoor unit, install the condenser air inlets and outlets facing away from direct winds.
8. Consider tie-down requirements in case of high winds or where required by local codes.



### Planning for Snow and Ice, continued.

#### ⚠ CAUTION

When deciding on a location to place the outdoor unit, be sure to choose an area where run-off from defrost will not accumulate and freeze on sidewalks or driveways, which will create unsafe conditions. Properly install and insulate any drain hoses to prevent the hose from freezing, cracking, leaking, and causing unsafe conditions from frozen condensate.

### Rooftop Installations

If the outdoor unit is installed on a roof structure, be sure to level the unit. Ensure the roof structure and anchoring method are adequate for the unit location. Consult local codes regarding rooftop mounting.

### Oceanside Installation Precautions

- Install the outdoor unit on the side of the building opposite from direct ocean winds.
- Select a location with good drainage.
- Periodically clean dust or salt particles off of the heat exchanger with water.



Avoid installing the outdoor unit where it would be directly exposed to ocean winds.

#### Note:

Additional anti-corrosion treatment will need to be applied to the outdoor unit at oceanside locations.

### Tie-Downs and Lightning Protection

#### Tie-Downs

- The strength of the roof must be checked before installing the outdoor units.
- If the installation site is prone to high winds or earthquakes, when installing on the wall or roof, securely anchor the mounting base using a field-provided tie-down configuration approved by a local professional engineer.
- The overall tie-down configuration must be approved by a local professional engineer. Always refer to local code when using a wind restraint system.

#### Lightning Protection

- To protect the outdoor unit from lightning, it must be placed within the specified lightning safety zone.

Table 7: Safety Zone Specifications.

Building Height (feet)	66	98	148	197
Protection Angle (°)	55	45	35	25

- Power cable and communication cable must be installed five (5) feet away from lightning rod.
- A high-resistance ground system must be included to protect against induced lightning or indirect strike.

#### Note:

If the building does not include lightning protection, the outdoor unit will be damaged from a lightning strike. Inform the customer of this possibility in advance.



#### Note:

Ocean winds will cause corrosion, particularly on the condenser and evaporator fins, which, in turn could cause product malfunction or inefficient performance.

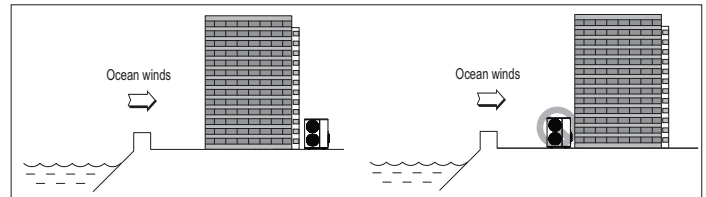

If the outdoor unit must be placed in a location where it would be subjected to direct ocean winds, install a concrete windbreaker strong enough to block any winds. Windbreaker height and width must be more than 150% of the outdoor unit, and be installed at least 27-1/2 inches away from the outdoor unit to allow for airflow.

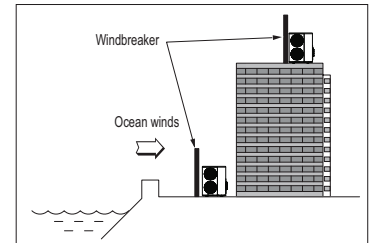
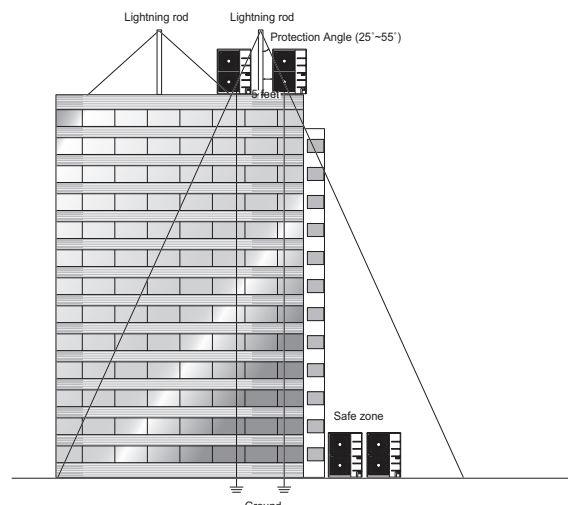

Figure 4: Lightning Protection Diagram.



# PLACEMENT CONSIDERATIONS

## Selecting the Best Location for the Outdoor Unit

MULTI F WITH LGRED<sup>®</sup>  
MULTI F MAX

### Minimum Allowable Clearance and Service Access Requirements

Proper clearance for the outdoor unit coil is critical for proper operation. When installing the outdoor unit, consider service, inlet and outlet, and minimum allowable space requirements as illustrated in the diagrams on the following pages.

- Include enough space for airflow and for service access. If installing multiple outdoor units, ⓧ avoid placing the units where the discharge of one unit will blow into the inlet side of an adjacent unit.
- If an awning is built over the unit to prevent direct sunlight or rain exposure, make sure that the discharge air of the outdoor unit isn't restricted.
- ⓧ No obstacles to air circulation around the unit; keep proper distances from ceilings, fences, floor, walls, etc. (Install a fence to prevent pests from damaging the unit or unauthorized individuals from accessing it.)

### Multi F with LGRED Outdoor Unit (18,000, 24,000, 30,000 Capacities) Service Access and Allowable Clearances

Specific clearance requirements in the diagram below are for (18,000, 24,000, 30,000 Btu/h capacities). Figure 5 shows the overall minimum clearances that must be observed for safe operation and adequate airflow around the outdoor unit.

When placing the outdoor unit under an overhang, awning, sunroof or other "roof-like structure", observe the clearance requirements (as shown in Cases 1 and 2) for height in relation to the unit. To have successful service access to the outdoor unit, see Figure 5 for minimum spacing. When installing multiple outdoor units, see Cases 4 and 5 for correct spacing requirements.

#### Note:

If the outdoor unit is installed between standard and minimum clearances, capacity decreases approximately 10%.

Figure 5: Multi F with LGRED 18,000, 24,000, 30,000 Capacity Outdoor Unit Service Access and Allowable Clearances Diagram.

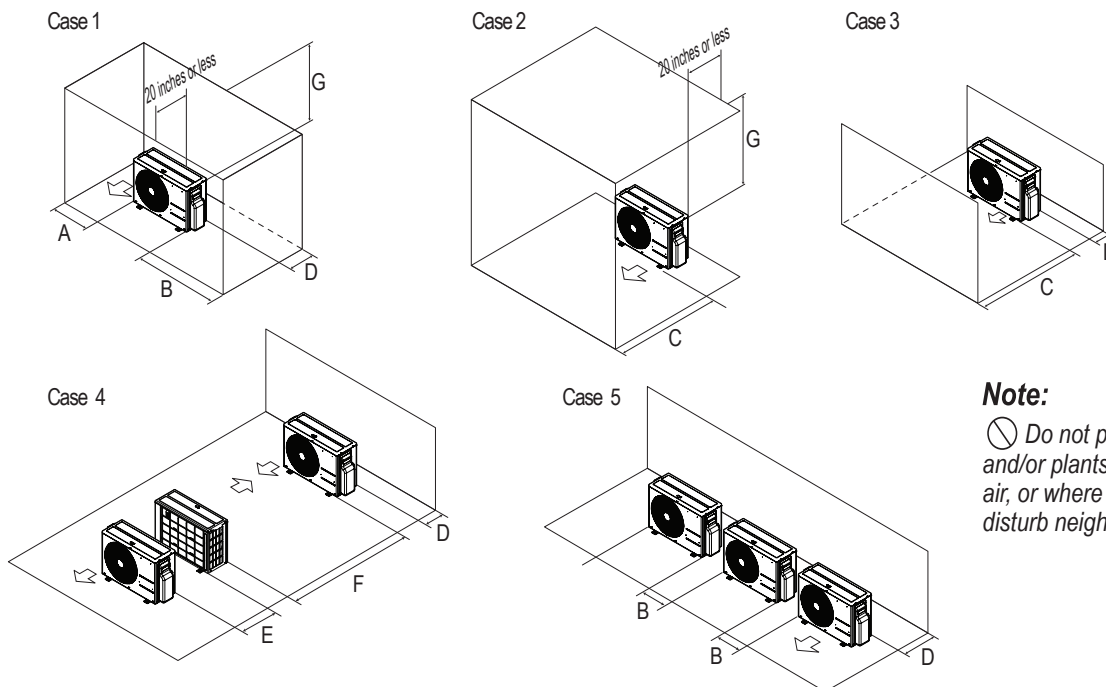

#### Note:

ⓧ Do not place the unit where animals and/or plants will be in the path of the warm air, or where the warm air and/or noise will disturb neighbors.

Table 8: Multi F with LGRED 18,000, 24,000, and 30,000 Outdoor Unit Service Access and Allowable Clearances Diagram Legend.

Unit: Inch		A	B	C	D	E	F	G
Case 1	Standard	12	24	-	12	-	-	-
	Minimum	4	10	-	4	-	-	40
Case 2	Standard	-	-	20	-	-	-	-
	Minimum	-	-	14	-	-	-	40
Case 3	Standard	-	-	20	12	-	-	-
	Minimum	-	-	14	4	-	-	-
Case 4	Standard	-	-	-	12	24	-	-
	Minimum	-	-	-	4	8	79	-
Case 5	Standard	-	24	-	12	-	-	-
	Minimum	-	10	-	4	-	-	-

### Multi F MAX with LGRED Outdoor Unit (36,000 and 42,000 Btu/h Capacity) Service Access and Allowable Clearances

When installing the outdoor unit, consider service, inlet, and outlet, and minimum allowable space requirements as illustrated in the following diagrams.

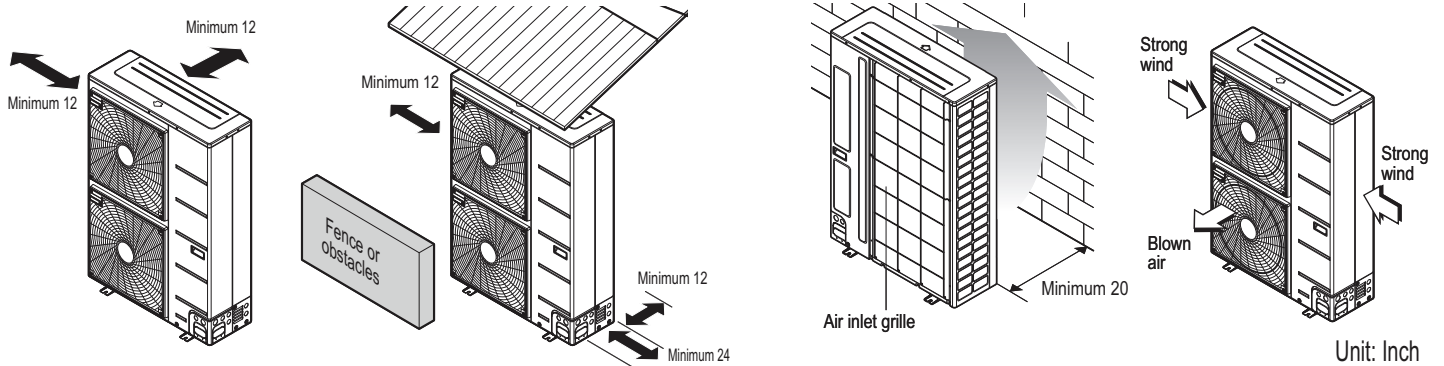

Ensure that the space at the back of the outdoor unit is a minimum of 12 inches, and include a minimum of 24 inches at the right side of the unit for service.

If the outdoor unit discharge side faces a wall, include a minimum of 20 inches between the outdoor unit and the wall. Install the outdoor unit so that the discharge port is set at a right angle to the wind direction.

Unit: Inch

### Clearance Requirements when Different Obstacles are Present (Unit: Inch).

Obstacle on the suction side only.

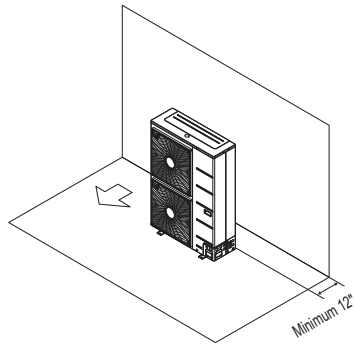

Obstacles on the suction side and on both left and right sides.

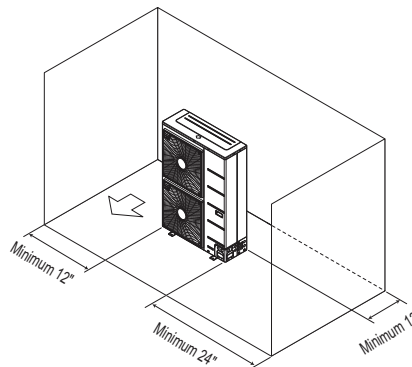

Obstacles above and on the air intake

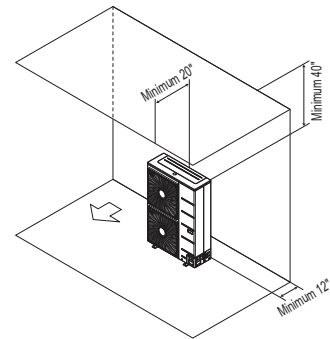

Obstacle on the suction side. Obstacles above, on the air intake side, and on both left and right sides

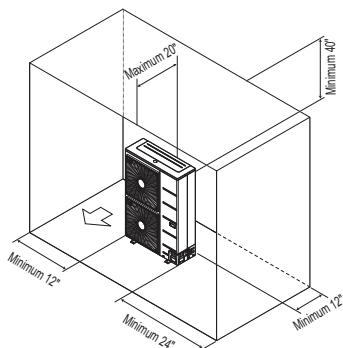

Obstacle just on the air discharge side.

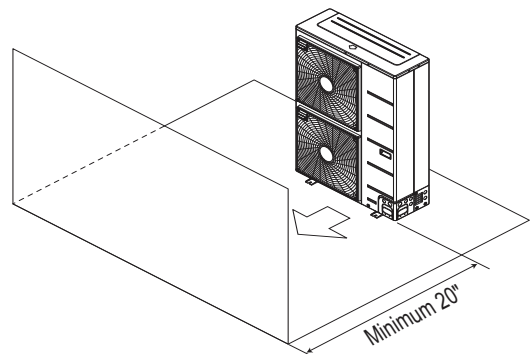

# PLACEMENT CONSIDERATIONS

Selecting the Best Location for the Outdoor Unit

MULTI F WITH LGRED<sup>®</sup>  
MULTI F MAX

## Clearance Requirements when Different Obstacles are Present, continued. (Unit: Inch)

Obstacles above and on the air discharge side.

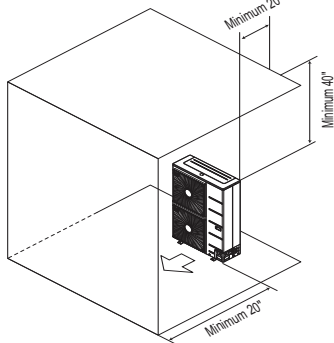

Where there are obstacles on both suction and discharge sides (discharge side obstacle is higher than the outdoor unit).

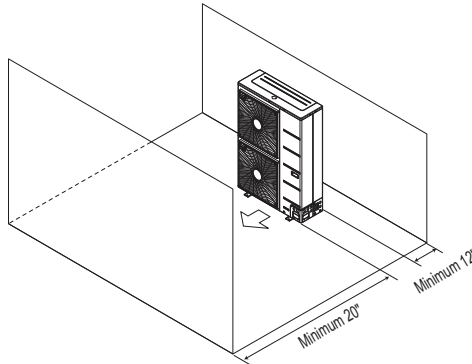

Where there are obstacles on both suction and discharge sides (discharge side obstacle is lower than the outdoor unit).

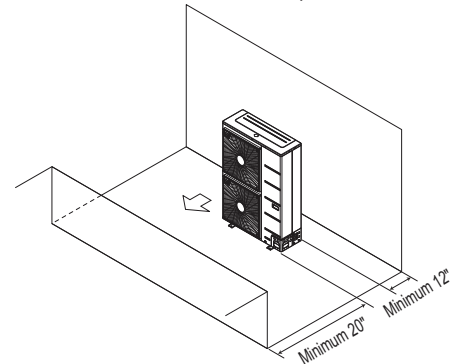

Where there are obstacles above, and on both suction and discharge sides (discharge side obstacle is higher than the outdoor unit).

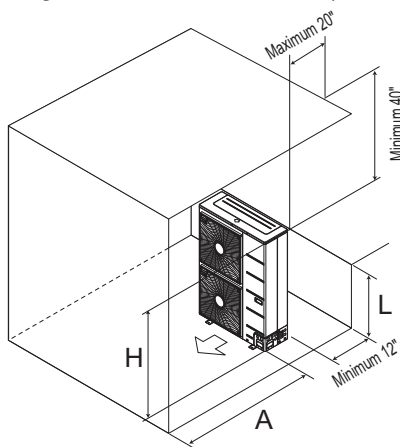

Where there are obstacles above, and on both suction and discharge sides (discharge side obstacle is lower than the outdoor unit).

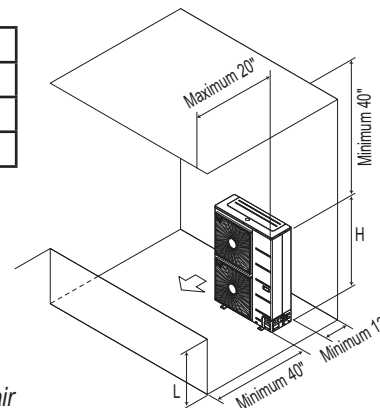

Table 9: Ratio among H, A, and L.

	L	A
L ≤ H	0 < L ≤ 1/2 H	30 inches
	1/2 H < L	40 inches
H < L	Set Stand as: L ≤ H	

If a stand is necessary, it must be contained (not open frame) to prevent the discharge air from short cycling.

### Note:

"L" must be lower than "H". If a stand is necessary, it must be contained (not open frame) to prevent the discharge air from short cycling.

### Series installation

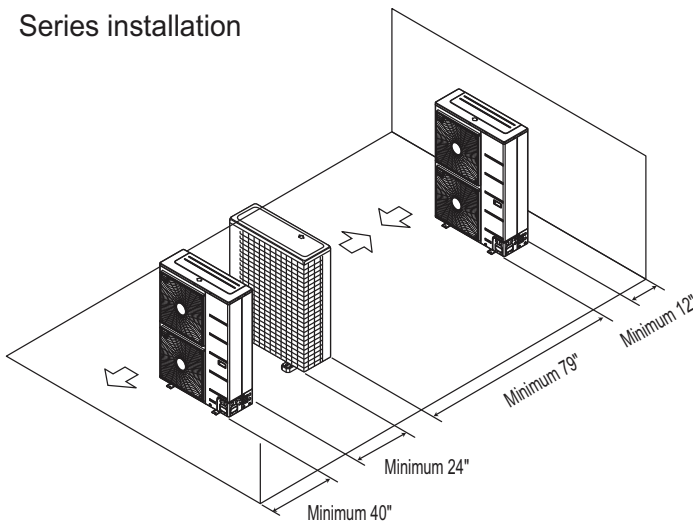

### Side-by-side series installation.

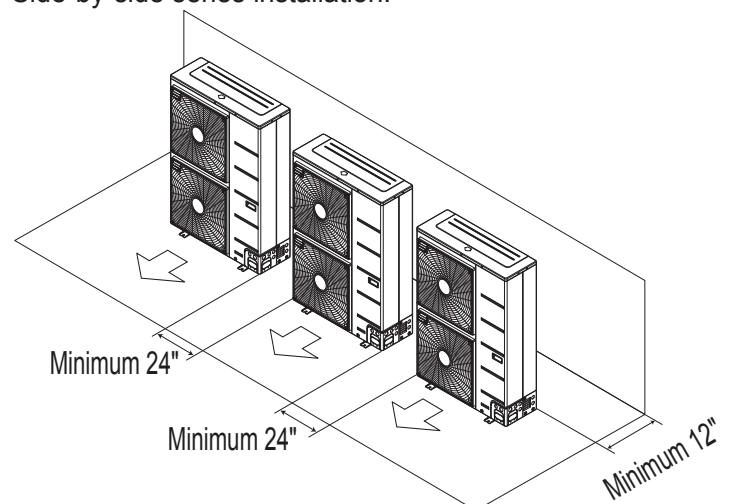

### Installing Outdoor Units Indoors

LG Multi F / Multi F MAX with LGRED outdoor units are engineered to be mounted outdoors and include technology designed to minimize the negative effects of winter weather's freezing rain, sleet, and snow. Some building projects, however, necessitate placing the HVAC outdoor units indoors:

- Lack of ground space.
- Lack of an appropriate outdoor location that meets system design requirements.
- When mounting on the roof is not an option due to a lack of roof space.
- Roof warranty will be voided if mechanical equipment is placed on the membrane.
- On retrofit projects, a former chiller / boiler / air handler equipment room, mechanical area, or penthouse already exists.
- To curtail the potential need for redundant zone heating devices such as wall-fin radiators or duct heaters.
- In extremely cold environments where there is a significant amount of run-time at temperatures well below freezing outside the outdoor unit ambient air temperature range published in this engineering manual.

### Benefits of Installing Outdoor Units Indoors

- Shelters the outdoor unit from direct exposure to prevailing winds that decrease the heating capability of the outdoor unit.
- Protects equipment from freezing precipitation and/or potential ice build-up that could hinder unit operation.
- Maintains coil heat transfer efficiency by reducing the number of and shortening the cycle time for defrost operation.
- Easier maintenance and servicing during inclement weather.
- When mounted in a fully enclosed space, limiting the ambient air temperature will allow the Multi F / Multi F MAX with LGRED system designer to eliminate oversizing.
- The outdoor unit to compensate for loss of capacity at low ambient temperatures.
- Will also curtail the need to provide inefficient redundant zone heating devices such as wall-fin radiators and second-stage ancillary heating devices.

### Design Considerations Include:

- Enclosure types and elements such as louvers (see next page), rain hoods, dampers and controls, heating methods and sizing of heating devices.
- Heating strategies.
- Duct design.
- Condensate handling.

### General Guidelines

- Follow ASHRAE 62.1 design guidelines.
- Depending on the project / application, a roof over the outdoor units in combination with a wind break will be all that is necessary.
- Consider the potential for snow accumulation near louvers / roof openings. Outside air intakes and discharge ducts/louvers must be engineered to clear anticipated snow accumulation levels by at least one (1) foot.
- In situations where operation is anticipated at temperatures of -13°F and lower, ancillary heat must be provided to heat the outdoor unit coils to assure continuous compressor operation and heating.

It will be necessary to use a field-fabricated air guide to prevent discharge air from short-cycling back to the coil inlet.

- Consider the direction of prevailing winds and opening placement. If possible, locate inlet openings upwind of discharge openings and other exhaust outlets.
- When inlet and outlet openings are placed on the same wall, minimum distance between the two openings must be approximately three (3) feet (minimum distance varies significantly with variations in outlet opening face velocity).
- If roof-mounted ventilation openings are used, strategically locate the inlet ventilation opening(s) upwind of the outlet opening(s).
- Discharge and supply ductwork must be designed to avoid weather related long periods of water entrainment and the potential for microbial growth.



# PLACEMENT CONSIDERATIONS

MULTI F WITH LGRED°  
MULTI F MAX

## Selecting the Best Location for the Outdoor Unit

Provide a means to drain the condensate generated during heating mode and defrost cycle in addition to rainwater that infiltrates the inlet louver enclosed area.

- Install a field-provided drain pan under the outdoor units and provide a path to a nearby floor drain.
- If the ambient air temperature is expected to drop below 32°F in the enclosure, heat the bottom surface of the pan, drain line, and floor drain so that the condensate does not freeze before reaching the drain.

### CAUTION

When deciding on a location to place the outdoor unit, be sure to choose an area where run-off from defrost will not accumulate and freeze on sidewalks or driveways which will create unsafe conditions.

Allow for ventilation intake and exhaust air based on maximum outdoor unit fan capacity.

- Select the size, type and orientation of architectural louvers with adequate “net free area” face velocity to ensure the total external static pressure from the outdoor unit fan does not exceed design limitations (see specification data tables).
- No obstructions must be placed in front of the louver that could hamper the free flow (throw) of air.
- Roof top openings and / or discharge and supply louvers must be equipped with screens to prevent bird and insect infiltration.

### Note:

For louver recommendations, see below and on the next page.

As always, the best solution for each project balances acceptable heating performance (considering local weather conditions), capital costs, life cycle energy consumption, and limitations set forth by local building codes.

## Louver Recommendations for Outdoor Unit Enclosure

1. Outdoor Unit Enclosure: Manual Door Open Type.
2. Louver Angle: No More Than 15° Horizontally.
3. Space Between Louvers: More than 4 inches (Recommend).
4. Louver Shape: Wing or Plane Type.

### Note:

- Open Rate and Inlet must be taken into consideration when designing the louvered outdoor unit enclosure.
- Do not use “S” type louvers.

### Note:

#### If the Louver Open Rate is Too Small

1. Noise can occur because of the increased air velocity passing through the louver blade.
2. Noise can occur from louver blade vibrations.
3. A drop in outdoor unit fan performance (excess static pressure can cause a drop in outdoor unit performance and heat exchanger efficiency).
4. If the louver open rate is too small or there is insufficient air flow exchange, the air conditioner might stop operating.

Figure 6: Louver Recommendations.

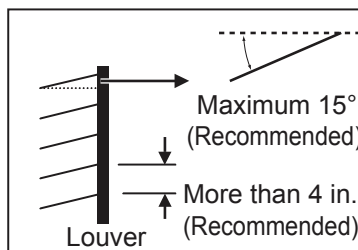
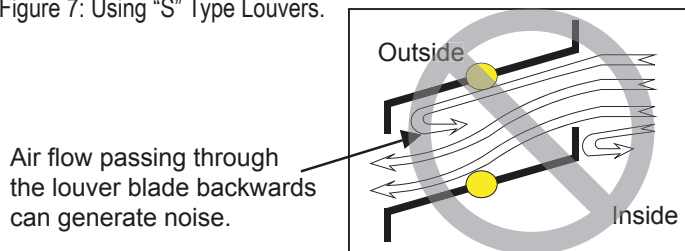
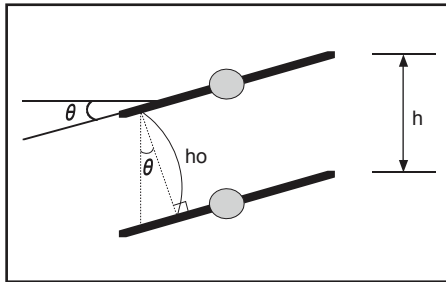

Figure 7: Using “S” Type Louvers.



### Open Rate by Louver Radian

Figure 8: Open Rate by Louver Radian Formula.



$\theta \leq 15$   
 $h_o = h * \text{COS } \theta$   
 Total Area (A) = H \* W  
 Number of Open Spaces (N) = (Number of Louvers - 1)  
 Effective Area (Af) =  $h_o * W * N$   
 Louver Open Rate (n) = Af / A

$\therefore Af = A * n$

Effective Cross Section Area

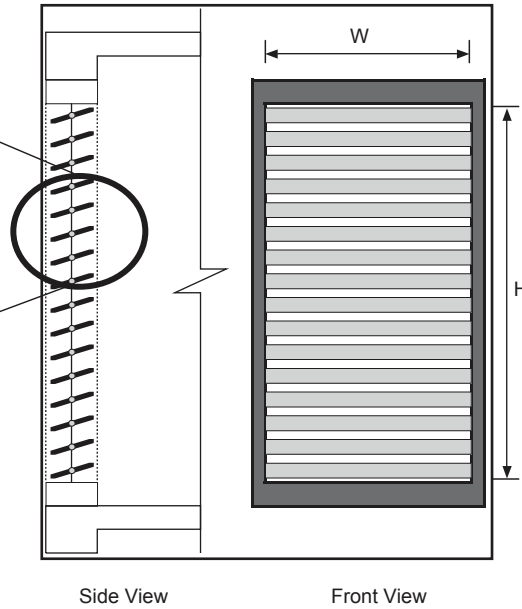

### Confirming Air Flow Rate / Total Opening Rate

• Example: LMU360HHV

• Airflow Rate: 2,119 ft.<sup>3</sup>/min.

• Velocity of Outlet Air: 16.4 ft./s

• Velocity of Inlet Air: 8.2 ft./s

• Open Rate = 80% or More

$$\text{Open Rate} = \frac{\text{Effective Face Area (Af)}}{\text{Total Face Area (A)}}$$

• Discharge Air Guide must be installed.

Figure 9: Example of Installing Outdoor Unit Indoors.

Louver Dimensions

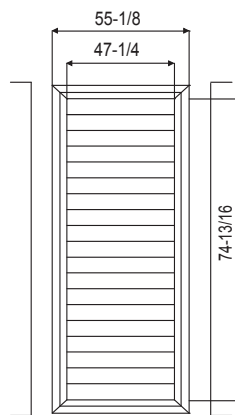

Unit: Inch

Air Guide Duct on Outdoor Unit

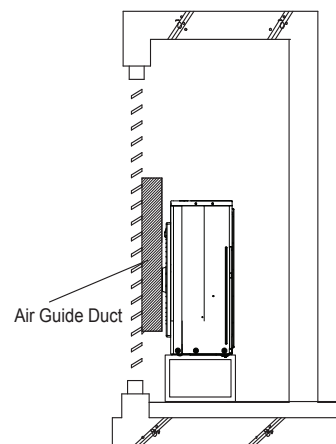

Outdoor Unit Dimensions

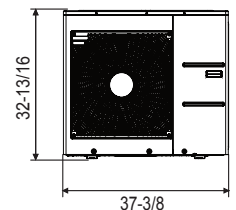

### Formula

• Total Louver Dimension (Excluding Frame) (A) = 3.9 feet x 6.2 feet = 24.2 ft.<sup>2</sup>

• Louver Shield Dimension by Product (B) = 3.12 feet x 2.74 feet = 8.55 ft.<sup>2</sup>

• Inlet Louver Dimension (A - B) = 15.7 ft.<sup>2</sup>

• Equivalent Inlet Dimension (Open Rate 80%) = 15.7 ft.<sup>2</sup> x 0.8 = 12.56 ft.<sup>2</sup>

• Equivalent Inlet Air Volume = 12.56 ft.<sup>2</sup> x 8.2 ft./s x 60 sec./min. = 6,179.5 ft.<sup>3</sup>/min.

• Required Air Volume / Equivalent Volume = 6,179.5 ft.<sup>3</sup>/min. / 2,119 ft.<sup>3</sup>/min. = 291% (Within Allowable Limits)



# PLACEMENT CONSIDERATIONS

MULTI F WITH LGRED<sup>®</sup>  
MULTI F MAX

## Selecting the Best Location for the Indoor Units / Branch Distribution Units

### Selecting the Best Location for the Indoor Units

#### Note:

Select a location for installing the indoor units that will meet the following conditions:

- Within allowable parameters for proper connection to the outdoor unit (and branch distribution unit, if a Multi F MAX with LGRED system).
- So that condensation drainage can be conveniently routed away.
- Include enough space around the indoor unit so that it is accessible for maintenance and service purposes.
- Where electrical noise / electromagnetic waves will not affect indoor unit operation. Maintain proper distances between the indoor units and electric wires, audio and visual appliances, breaker / circuit panels, etc. If the frequency signal of the appliance is unstable, then install the indoor unit a minimum of ten (10) feet away, and run the power and transmission cables through a conduit.
- An area that is level and with enough strength to bear the weight of the indoor unit(s).

#### Do Not's

- Install in an area with obstacles to air circulation around the unit; keep proper distances from ceilings, doorways, floor, walls, etc.
- Install in an area where operation sound will disturb occupants.
- Install in an area that exposes the indoor unit(s) to heat, water, steam, oil splattering or spray.

#### Note:

Indoor units (IDUs) must not be placed in an environment where the IDUs will be exposed to harmful volatile organic compounds (VOCs) or in environments where there is improper air make up or supply or inadequate ventilation. If there are concerns about VOCs in the environment where the IDUs are installed, proper air make up or supply and / or adequate ventilation must be provided. Additionally, in buildings where IDUs will be exposed to VOCs consider a factory-applied epoxy coating to the fan coils for each IDU.

For detailed placement considerations and installation requirements for indoor units, refer to its Indoor Unit Engineering and / or Installation Manuals.

### Selecting the Best Location for the Branch Distribution (BD) Units

#### Note:

Branch distribution (BD) units are used only with Multi F MAX with LGRED systems to distribute the refrigerant from the outdoor unit up to six (6) indoor units.

Select a location indoors that will meet the following conditions:

- Within allowable parameters for proper connection to the Multi F MAX with LGRED outdoor unit and indoor unit(s); refrigerant piping and wire lengths must not exceed amounts specified by LG Electronics, U.S.A., Inc.
- Condensate drain piping is not required.
- Ensure there is enough space in the installation area for service purposes (minimum 24 inches); install the refrigerant piping and electrical wiring system in an easily accessible location.
- Level where there is enough strength to bear the weight of the branch distribution unit.

#### Do Not's

- Install the branch distribution unit in a location where it would be subjected to strong radiation heat from heat sources.
- Install in an installation environment where the branch distribution unit would be exposed to heat, water, steam, oil splattering or spray.
- Install the unit in a location where any sound it generates will disturb occupants in the surrounding rooms.
- Install in a location where there are obstacles to air circulation around the unit; keep proper distances from ceilings, doorways, floor, walls, etc.
- Install in an area where high-frequency electrical noise / electromagnetic waves will affect operation. Maintain proper distances between the branch distribution unit(s) and electric wires, audio and visual appliances, breaker / circuit panels, etc.

Figure 10: Branch Distribution Unit Key Components.

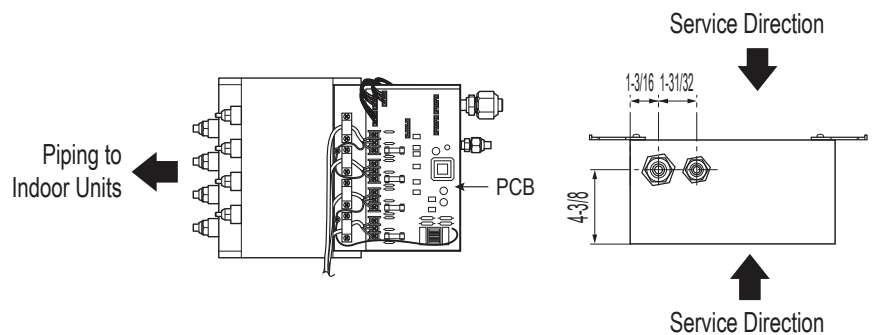

# PLACEMENT CONSIDERATIONS

Selecting the Best Location for the Branch Distribution Units

A-C (and PMBD3640 D) Connections:  
Liquid Pipe Ø1/4  
Gas Pipe Ø3/8

PMBD3641 D Connections:  
Liquid Pipe Ø1/4  
Gas Pipe Ø1/2

Unit: Inch

Indoor Unit  
Piping Direction ←

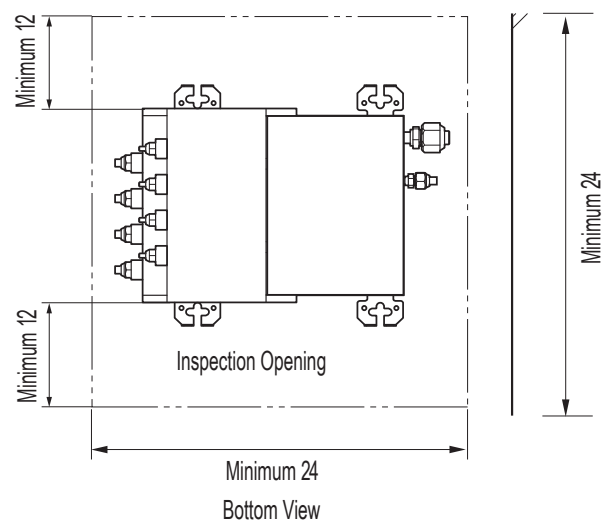
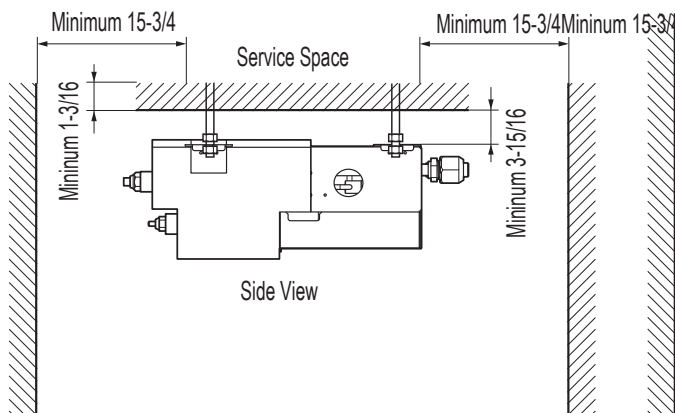
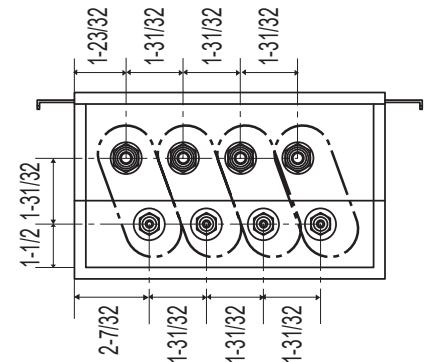
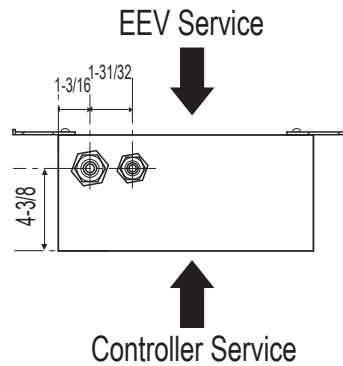
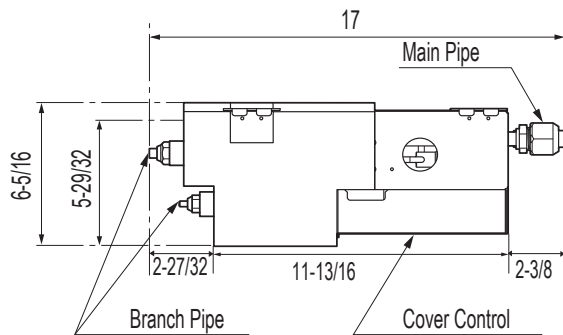
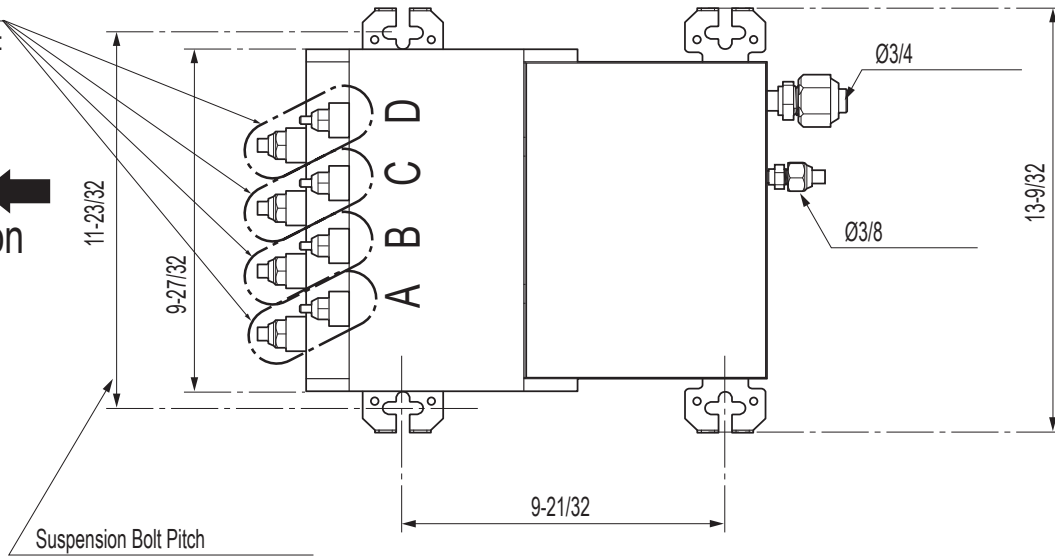

Notes:

1. For PMBD3620 Unit, Ports A and B are Available.
2. For PMBD3630 Unit, Ports A, B, and C are Available.
3. For PMBD3640 and PMBD3641 Units, Ports A, B, C, and D are Available.

Installation

# MOUNTING / ANCHORING THE OUTDOOR UNITS

## Mounting / Anchoring the Outdoor Unit General Specifications

- Tightly anchor the outdoor unit with a bolt and nut to a concrete or rigid platform.
- When installing on a wall (with field-supplied brackets), roof, or rooftop, securely anchor the mounting platform with nails and / or wiring, taking into consideration the possibility of strong winds or earthquakes.
- If installing the outdoor unit on the roof, check the strength of the roof.

### Outdoor Unit Platform Concrete Specifications

- Concrete foundations must be made of one part cement, two parts sand, and four parts gravel.
- The surface of the foundation must be finished with mortar with rounded edges, and weatherproofed.
- See table and figures for height, width, etc., requirements.
- Include an area for drainage around the foundation to ensure condensate thoroughly drains away from the outdoor unit.

Figure 12: Close up of Bolt Attachment.

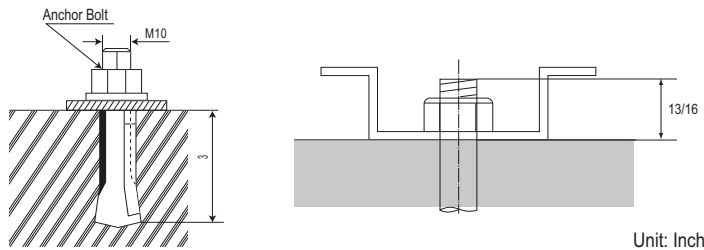
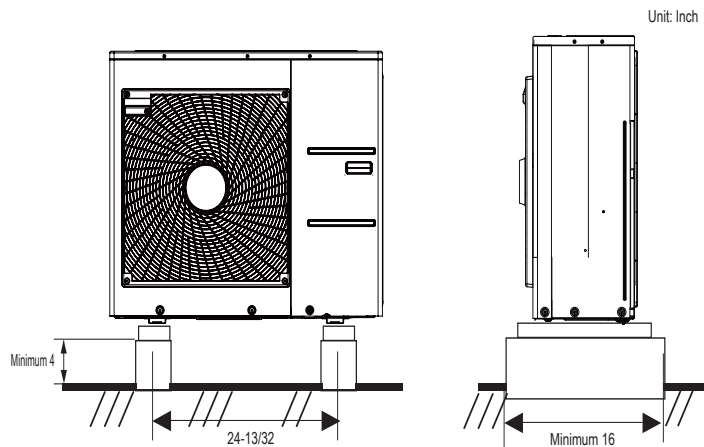

Figure 13: LMU180HHV, LMU240HHV, and LMU300HHV Outdoor Units.



### Bolting the Outdoor Unit to the Platform Procedure

1. Ensure that the concrete platform will not degrade easily, and has enough strength to bear the weight of the unit.
2. Include an H-beam support. Firmly attach the corners, otherwise the support will bend.
3. Use a hexagon nut.
4. If there is a possibility of vibration from the outdoor unit transmitting to the building, add an anti-vibration material to the platform.
5. Include enough space around the concrete foundation for condensate drainage.
6. Seal all wiring and piping access holes with field-supplied sealing material to prevent animals and bugs from entering the unit.

Figure 11: Example of Using an Insert for a Hole in a Reinforced Concrete Beam.

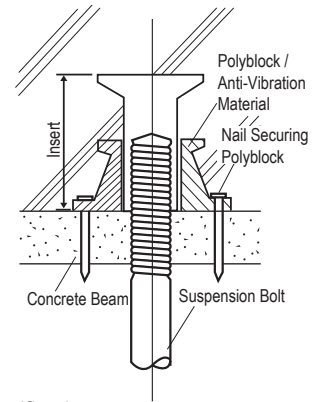

Table 10: Outdoor Unit Foundation Specifications.

Outdoor Unit	Bolt Type	Concrete Height	Bolt Depth
LMU180HHV, LMU240HHV, LMU300HHV	M10-J	Minimum Four (4) Inches	Minimum Three (3) Inches
LMU360HHV, LMU420HHV	M10-J	Minimum Eight (8) Inches	Minimum Three (3) Inches

Figure 14: LMU360HHV and LMU420HHV Outdoor Units.

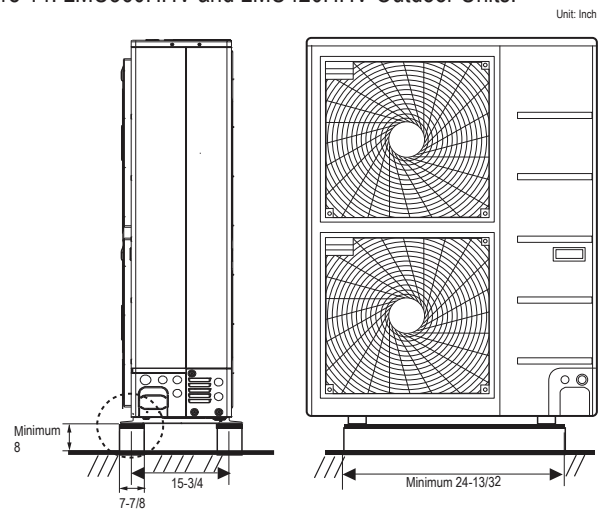
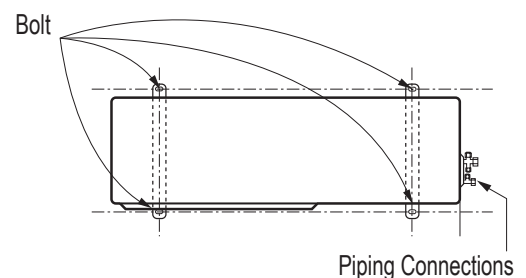

Figure 15: Bolting the Outdoor Unit to the Platform (Piping Location Will Differ Depending on Outdoor Unit Model).



## Branch Distribution Unit Orientation

Multi F MAX with LGRED branch distribution (BD) units can be installed in a multitude of options to fit various building configurations and job or application requirements (suspended from the ceiling or mounted on the wall). The installation location of the PCB within the branch distribution unit can be changed for easier service access, depending on the branch distribution unit installation itself (see the wiring section for information). Branch distribution units include electronic expansion valves that properly seat only if the branch distribution unit is installed in an acceptable orientation. Installations with improper branch distribution unit orientation risk incomplete valve seating and system performance degradation from potential refrigerant leakage through the electronic expansion valve.

### Note:

*This material is for informational or educational purposes only. It is not intended to be a substitute for professional advice. Consult with your engineer or design professionals for specific applications to your system.*

## Ceiling Mount Installation - Hangers with Hanging Bolt

1. Drill four (4) holes in the ceiling, following the dimensions on the previous page.
2. Attach the factory-supplied hangers with two (2) screws each at the designated four (4) areas on the frame of the branch distribution unit.
3. Install an anchor in the ceiling, and attach the hanging bolts to the ceiling.
4. Add nuts and washers to the hanging bolt as shown at right.
5. Hang the branch distribution unit on the hanging bolts (ceiling side up), and after checking for level ( $\pm 5$  degrees), securely tighten all nuts.

Figure 17: Branch Distribution Ceiling Mount Installation.

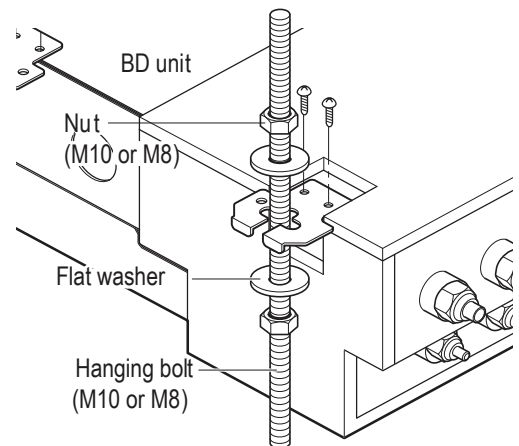

Installation

## Ceiling Mount Installation - Hangers Only

1. Attach the factory-supplied hangers with two (2) screws each at the designated four (4) areas on the frame of the branch distribution unit.
2. Install the branch distribution unit to the ceiling using two screws on each of the hangers as shown below. Unit must be  $\pm 5$  degrees of level.
3. Cover parts of the hanger holes with polyethylene foam insulation (to prevent condensation).

### Note:

*If a screw has been installed on the frame of the branch distribution unit and the screw has been removed, to prevent condensation, either re-install the screw or cover the open hole with aluminum tape.*

Figure 16: Acceptable Branch Distribution Unit Ceiling Mount Orientations.

### Ceiling Mounting Options

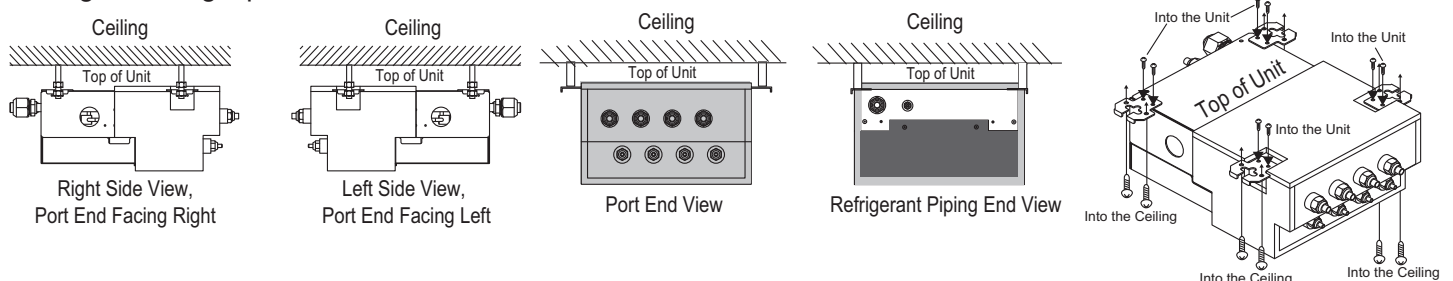

# MOUNTING / ANCHORING THE BRANCH DISTRIBUTION UNITS

MULTI F WITH LGRED<sup>®</sup>  
MULTI F MAX

## Wall Mount Installation - Hangers Only

1. Attach the factory-supplied hangers with two (2) screws each at the designated four (4) areas on the frame of the branch distribution unit.
2. Install the branch distribution unit to the wall using two screws on each of the hangers. Unit must be  $\pm 5$  degrees of level.
3. Cover parts of the hanger holes with polyethylene foam insulation (to prevent condensation).

Figure 19: Acceptable Branch Distribution Unit Wall Mount Orientations.

### Wall Mounting Options

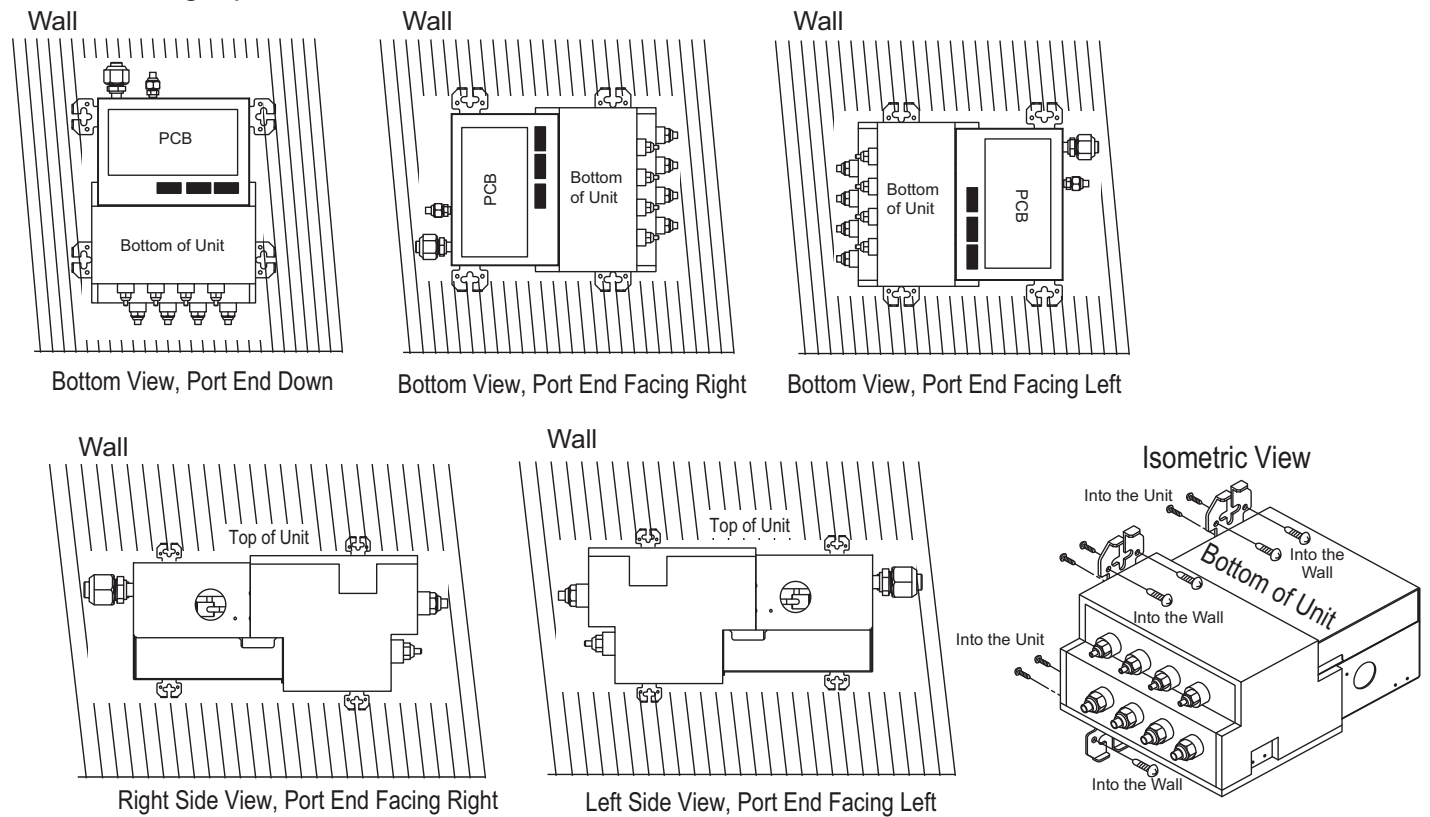
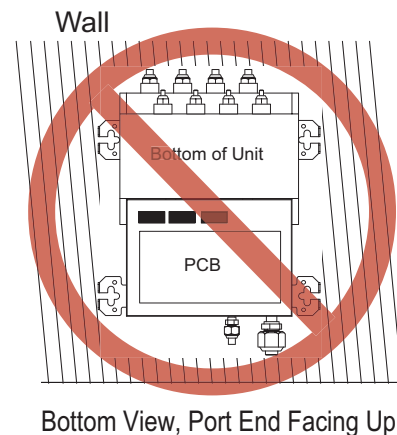

Figure 18: Unacceptable Branch Distribution Unit Orientation.





## LG Air Conditioner Technical Solution (LATS) Software

A properly designed and installed refrigerant piping system is critical to the optimal performance of LG air-conditioning systems. To assist engineers, LG offers, free of charge, LG Air Conditioner Technical Solution (LATS) software—a total design solution for LG air conditioning systems.

### Note:

To reduce the risk of designing an improper applied system or one that will not operate correctly, LG prefers that LATS software be used on all projects.

### Formats

LATS is available to LG customers in three user interfaces: LATS HVAC, LATS CAD2, and LATS Revit. All three LATS formats are available through [www.myLGHVAC.com](http://www.myLGHVAC.com), or contact an LG Sales Representative.

**LATS HVAC** is a Windows®-based application that aids engineers in designing LG Variable Refrigerant Flow (VRF), Multi F / Multi F MAX, Multi F / Multi F MAX with LGRED, Single-Zone, and Energy Recovery Ventilator (ERV) systems.

\*Windows® is a registered mark of Microsoft® Corporation.

**LATS CAD2** combines the LG LATS program with AutoCAD® software\*\*. It permits engineers to layout and validate LG Multi V Variable Refrigerant Flow (VRF), Multi F / Multi F MAX, Multi F / Multi F MAX with LGRED, Single-Zone, and Energy Recovery Ventilator (ERV) systems directly into CAD drawings.

**LATS Revit** integrates the LG LATS program with Revit® software\*\*. It permits engineers to layout and validate Multi V VRF systems directly into Revit drawings.

\*\*AutoCAD® and Revit® are both registered marks of Autodesk, Inc.

### Features

All LG product design criteria have been loaded into the program, making LATS simple to use: double click or drag and drop the component choices. Build systems in Tree Mode where the refrigerant system can be viewed. Switch to a Schematic diagram to see the electrical and communications wiring.

LATS software permits the user to input region data, indoor and outdoor design temperatures, modify humidity default values, zoning, specify type and size of outdoor units and indoor units, and input air flow and external static pressure (ESP) for ducted indoor units.

The program can also:

- Import building loads from a separate Excel file.
- Present options for outdoor unit auto selection.
- Automatically calculate component capacity based on design conditions for the chosen region.
- Verify if the height differences between the various system components are within system limits.
- Provide the correct size of each refrigerant piping segment and LG Y-Branches and Headers.
- Adjust overall piping system length when elbows are added.
- Check for component piping limitations and flag if any parameters are broken.
- Factor operation and capacity for defrost operation.
- Calculate refrigerant charge, noting any additional trim charge.
- Suggest accessories for indoor units and outdoor units.
- Run system simulation.

### Note:

Features depend on which LATS program is being used, and the type of system being designed.

Figure 20: Example of LATS CAD2.



# LG AIR CONDITIONER TECHNICAL SOLUTION (LATS)

MULTI F WITH LGRED°  
MULTI F MAX

## LATS Generates a Complete Project Report

LATS software also generates a report containing project design parameters, cooling and heating design data, system component performance, and capacity data. The report includes system combination ratio and refrigerant charge calculations; and provides detailed bill of material, including outdoor units, indoor units, control devices, accessories, refrigerant pipe sizes segregated by building, by system, by pipe size, and by pipe segments. LATS can generate an Excel GERP report that can imported into the LG SOPS pricing and ordering system.

## Proper Design to Install Procedure

LG encourages a two report design-to-install-procedure. After the design engineer determines building / zone loads and other details, the engineer opens the LATS program and inputs the project's information. When the design is complete, the "Auto Piping" and "System Check" functions must be used to verify piping sizes, limitations, and if any design errors are present. If errors are found, engineers must adjust the design, and run Auto Piping and System Check again. When the design passes the checks, then the engineer prints out a project "Shop Drawing" (LATS Tree Diagram) and provides it to the installing contractor. The contractor must follow the LATS Tree Diagram when building the piping system, but oftentimes the design changes on the building site:

- Architect has changed location and/or purpose of room(s).
- Outdoor unit cannot be placed where originally intended.
- Structural elements prevent routing the piping as planned.
- Air conditioning system conflicts with other building systems (plumbing, gas lines, etc.).

The contractor must mark any deviation from the design on the Shop Drawing, including as-built straight lines and elbows. This "Mark Up" drawing must be returned to the design engineer or Rep, who must input contractor changes into the LATS file. (Copy the original LATS software file, save and rename as a separate file, and modify all piping lengths by double-clicking on each length and editing information.) Like the shop drawing, the Auto Piping and System Check must also be run on this new "As Built" drawing. The design engineer or Rep must then provide the final As Built file to the contractor. The Mark Up version must be compared to the As Built version for:

- Differences in pipe diameter(s). If incorrect diameters have been installed, the piping must be changed out. If pipe diameters have changed, check to see if Y-Branches will also need to be changed.
- Changes to outdoor unit and indoor unit capacities. Capacities changes will impact line length changes.
- Additional refrigerant charge quantity ("Trim Charge"). Trim charge will change if piping lengths and diameters change. The As Built version must reflect installed piping lengths to ensure correct trim charge.

All documents submitted by the contractor, as well as the Shop Drawing and the As Built Drawing files must be provided for commissioning purposes. Model and serial numbers for all system components must also be submitted. If the steps previously detailed are not followed, and all documents are not provided to the commissioning agent, the project runs the risk of not being commissioned and voiding any limited warranty LG offers on the equipment.

## Note:

Contact your LG representative for the vest software program for your application.

Figure 21: Example of a LATS Tree Diagram.

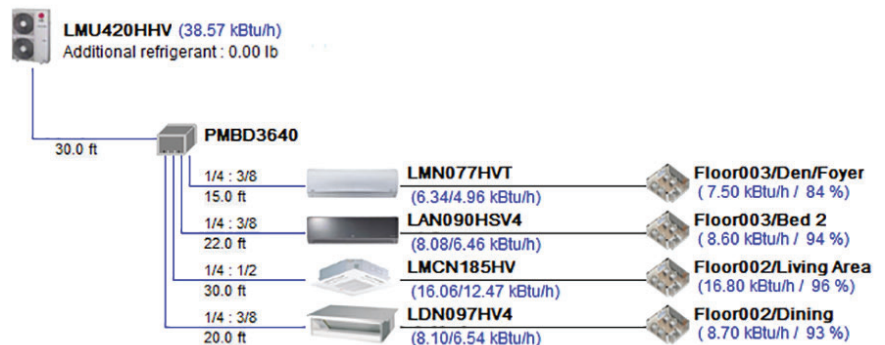



## Refrigerant Safety Standards

ASHRAE Standards 15-2010 and 34-2010 address refrigerant safety and the maximum allowable concentration of refrigerant in an occupied space. Refrigerant will dissipate into the atmosphere, but a certain volume of air is required to safely dissipate the refrigerant. For R410A refrigerant, the maximum allowable concentration of refrigerant is 26 lbs./1,000 cubic feet (Addendum L modified the RCL to 26) of occupied spaces. Buildings with 24-hour occupancy allow half of that concentration.

If a VRF system develops a refrigerant leak, the entire refrigerant charge of the system will dump into the area where the leak occurs. To meet ASHRAE Standards 15 and 34, the smallest room volume on the system must be calculated and compared to the maximum allowable concentration. If the concentration level is higher than allowed, the following are some design suggestions to eliminate the problem:

- Split dual-frame and triple-frame systems into single-frame systems that have lower refrigerant charges.
- Add transfer grilles in the ceiling or walls of the smaller rooms to increase the volume of the room.
- Remove the smallest space from the system and serve it with a smaller mini-split system.

## Device Connection Limitations

• The minimum number of connected and operating indoor units to Multi F / Multi F MAX with LGRED systems is two, taking into consideration the minimum combination ratio.

• The maximum number of indoor units for each Multi F / Multi F MAX with LGRED heat pump system is:

LMU180HHV = 2      LMU240HHV = 3      LMU300HHV = 4      LMU360HHV = 5      LMU420HHV = 6

### Note:

For allocated capacity information, see the combination tables in the "Multi F / Multi F MAX with LGRED Combination Data Manual" on [www.lghvac.com](http://www.lghvac.com). For performance data, see "Multi F / Multi F MAX with LGRED Performance Data Manual" on [www.lghvac.com](http://www.lghvac.com).

One of the most critical elements of multi-zone systems is the refrigerant piping. See below and the following page for pipe length limits that must be followed in the design of Multi F and Multi F MAX with LGRED refrigerant pipe systems:

## Multi F with LGRED Outdoor Unit Piping Length and Elevation Limitations

Figure 22: Multi F Refrigerant Piping System Limitations (LMU18CHV Example).

Table 11: Multi F with LGRED Outdoor Unit Refrigerant Piping System Limitations.

Outdoor Unit Model (Btu/h)	LMU180HHV / 18,000	LMU240HHV / 24,000	LMU300HHV / 30,000
Max. Total System Piping Length (ft.)	164 A+B	246.1 A+B+C	246.1 A+B+C+D
Min. Length for One Branch (ft.)	9.8	9.8	9.8
Max. Length for One Branch (ft.)	82	82	82
Max. Elevation Between Each Indoor Unit and Outdoor Unit (h1)	49.2	49.2	49.2
Max. Elevation Between Indoor Units (h2)	24.6	24.6	24.6
Max. Combination of Indoor Units	24,000	33,000	40,000

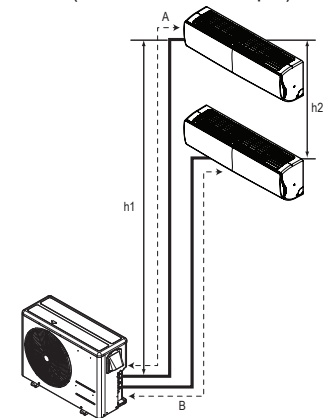

## Example of a Multi F with LGRED System

Example: LMU300HHV outdoor unit with four (4) indoor units connected.

ODU: Outdoor Unit.

IDU: Indoor Unit.

A, B, C, D: Pipes from Outdoor Unit to Indoor Unit.

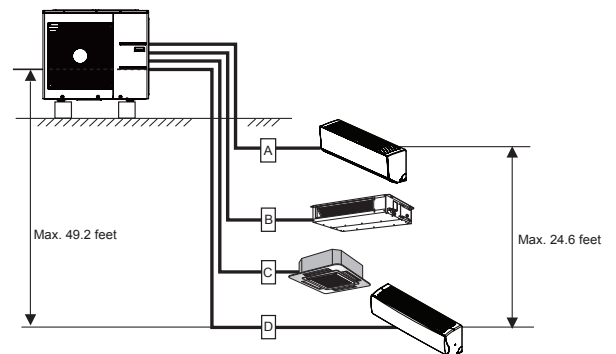

## Multi F MAX with LGRED Outdoor Unit Piping Length and Elevation Limitations

Table 12: Multi F MAX with LGRED Outdoor Unit Refrigerant Piping System Limitations.

Pipe Length (ELF = Equivalent Length of pipe in Feet)	Total piping length ( $\Sigma A + \Sigma B$ )		$\leq 475.7$ feet
	Main pipe (Outdoor Unit to Branch Distribution Units: $\Sigma A$ )	Minimum	9.8 feet
Maximum		$\leq 180.4$ feet	
Total branch piping length ( $\Sigma B$ )			$\leq 295.3$ feet
	Branch pipe (Branch Distribution Units to Indoor Units: B)	Minimum	10 feet
Maximum		$\leq 49.2$ feet	
Elevation Differential (All Elevation Limitations are Measured in Actual Feet)	If outdoor unit is above or below indoor unit ( $h_1$ )		$\leq 98.4$ feet
	Between the farthest two indoor units ( $h_2$ )		$\leq 49.2$ feet
	Between branch distribution unit and farthest connected indoor unit(s) ( $h_3$ )		$\leq 32.8$ feet
	Between branch distribution units ( $h_4$ )		$\leq 49.2$ feet
Max. Combination of IDUs	LMU360HHV = 48,000	LMU420HHV = 56,000	

Table 13: Multi F MAX with LGRED Piping Sizes.

Piping	Main Pipe A (inch)	Branch Pipe B
Liquid	$\varnothing 3/8$	Depends on the size of the indoor unit piping
Gas	$\varnothing 3/4$	

Figure 23: Multi F MAX Refrigerant Piping System Limitations.

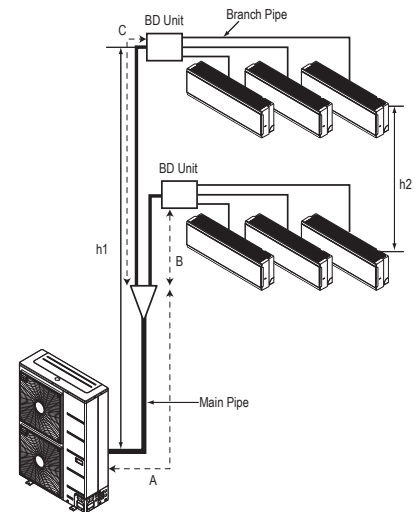

## Example of a Multi F MAX with LGRED System with Two Branch Distribution Units

Example: LMU420HHV outdoor unit with six (6) indoor units and two (2) branch distribution units connected.

ODU: Outdoor Unit.

IDU: Indoor Unit.

BD: Branch Distribution Unit(s).

$\Sigma A$ : Main Pipe.

$\Sigma B$ : Branch Pipe (Branch Distribution Unit[s] to Indoor Unit[s]).

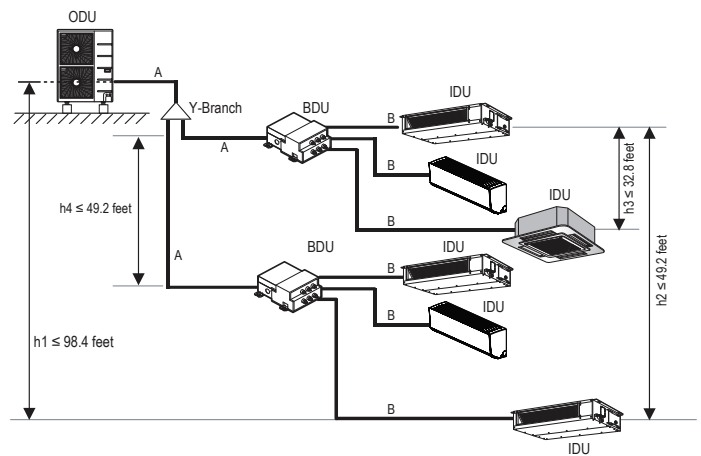

## Using Refrigerant Components

Field-supplied elbows are allowed as long as they are designed for use with R410A refrigerant. The designer, however, must be cautious with the quantity and size of fittings used, and must account for the additional pressure losses in equivalent pipe length calculation for each branch. The equivalent pipe length of each elbow must be added to each pipe segment.

Table 14: Equivalent Piping Length for Elbows, Y-branches, and Branch Distribution Units.

Component	Size (Inches)				
	1/4	3/8	1/2	5/8	3/4
Elbow (ft.)	0.5	0.6	0.7	0.8	1.2
Y-Branch Kit (ft., Multi F MAX with LGRED systems only) <sup>1</sup>	1.6				
Branch Distribution Unit (ft., Multi F MAX with LGRED systems only)	8.2				

## Selecting Field-Supplied Copper Piping

### Note:

Always follow local codes when selecting and installing copper pipe and piping system components.

Approved piping for use with LG HVAC products will be marked "R410 RATED" along the length of the pipe. Piping wall thickness must meet local code requirements and be approved for a maximum operating pressure of 551 psi. When bending piping, try to keep the number of bends to a minimum, and use the largest radii possible to reduce the equivalent length of installed piping; also, bending radii greater than ten (10) piping diameters can minimize pressure drop. Be sure no traps or sags are present.

### For Multi-Zone Split Systems

Use ACR copper piping rated at the system working pressure (rated for R410A refrigerant).

### Note:

Always properly support the piping as per the instructions on page 41.

Table 15: ACR Rated Copper Tubing Material.

Type	Seamless Phosphorous Deoxidized
Class	UNS C12200 DHP
Straight Lengths	H58 Temper
Coils	O60 Temper

Table 16: ACR Rated Piping Wall Thicknesses.

OD (in)	1/4	3/8	1/2	5/8	3/4	7/8	1-1/8	1-3/8	1-5/8
Material	Rigid or Soft ACR Rated for R410A			Rigid or Solid ACR Rated for R410A					
Min. Bend Radius (in)	0.563	0.9375	1.5	2.25	3.0	3.0	3.5	4.0	4.5
Min. Wall Thickness (in)	0.03	0.03	0.03	0.03	0.03	0.03	0.03	0.04	0.050

Table 17: ACR Copper Tubing Dimensions and Physical Characteristics<sup>1-3</sup>.

Nominal Pipe Outside Diameter (in)	Actual Outside Diameter (in)	Tempered (Hard Drawn)			Annealed (Soft)		
		Nominal Wall Thickness (in)	Weight (lb/ft)	Cubic ft per Linear ft	Nominal Wall Thickness (in)	Weight (lb/ft)	Cubic ft per Linear ft
1/4	0.250	--	--	--	0.030	0.081	0.00020
3/8	0.375	0.030	0.126	0.00054	0.032	0.134	0.00053
1/2	0.500	0.035	0.198	0.00101	0.032	0.182	0.00103
5/8	0.625	0.040	0.285	0.00162	0.035	0.251	0.00168
3/4	0.750	0.042	0.362	0.00242	0.042	0.362	0.00242
7/8	0.875	0.045	0.455	0.00336	0.045	0.455	0.00336
1-1/8	1.125	0.050	0.655	0.00573	0.050	0.655	0.00573
1-3/8	1.375	0.055	0.884	0.00875	0.055	0.884	0.00875
1-5/8	1.625	0.060	1.14	0.0124	0.060	1.14	0.0124

<sup>1</sup>All dimensions provided are in accordance with ASTM B280 – Standard.

<sup>2</sup>Design pressure = 551 psig.

<sup>3</sup>The Copper Tube Handbook, 2016, Copper Development Association Inc., 260 Madison Avenue, New York, NY 10016.

### Note:

- Commercially available piping often contains dust and other materials. Always blow it clean with a dry nitrogen.
- Prevent dust, water or other contaminants from entering the piping during installation.

# COPPER EXPANSION AND CONTRACTION

## Copper Expansion and Contraction

Under normal operating conditions, the vapor pipe temperature of a Multi F with LGRED system can vary as much as 180°F. With this large variance in pipe temperature, the designer must consider pipe expansion and contraction to avoid pipe and fitting fatigue failures.

Refrigerant pipe along with the insulation jacket form a cohesive unit that expands and contracts together. During system operation, thermal heat transfer occurs between the pipe and the surrounding insulation.

If the pipe is mounted in free air space, no natural restriction to movement is present if mounting clamps are properly spaced and installed. When the refrigerant pipe is mounted underground in a utility duct stacked among other pipes, natural restriction to linear movement is present. In extreme cases, the restrictive force of surface friction between insulating jackets could become so great that natural expansion ceases and the pipe is “fixed” in place. In this situation, opposing force caused by change in refrigerant fluid/vapor temperature can lead to pipe/fitting stress failure.

The refrigerant pipe support system must be engineered to allow free expansion to occur. When a segment of pipe is mounted between two fixed points, provisions must be provided to allow pipe expansion to naturally occur. The most common method is the inclusion of expansion Loop or U-bends mounted in the horizontal plane. When expansion loops are placed in a vertical riser, the loop is to be formed in a horizontal fashion resulting in a torsional movement during expansion and contraction. Each segment of pipe has a natural fixed point where no movement occurs. This fixed point is located at the center point of the segment assuming the entire pipe is insulated in a similar fashion. The natural fixed point of the pipe segment is typically where the expansion Loop or U-bend must be. Linear pipe expansion can be calculated using the following formula:

$$LE = C \times L \times (T_r - T_a) \times 12$$

LE	=	Anticipated linear tubing expansion (in.)
C	=	Constant (For copper = $9.2 \times 10^{-6}$ in./in.°F)
L	=	Length of pipe (ft.)
$T_r$	=	Refrigerant pipe temperature (°F)
$T_a$	=	Ambient air temperature (°F)
12	=	Inches to feet conversion (12 in./ft.)

1. From the table “Linear Thermal Expansion of Copper Tubing in Inches,” find the row corresponding with the actual length of the straight pipe segment.
2. Estimate the minimum and maximum temperature of the pipe. Typical pipe temperature change ranges: High Pressure Vapor: ambient temperature to 215°F; Low Pressure Vapor: ambient to 35°F; Liquid pipe: ambient, 80°F, 110°F. Choose the two most extreme. In the column showing the minimum pipe temperature, look up the anticipated expansion distance. Do the same for the maximum pipe temperature.
3. Calculate the difference in the two expansion distance values. The result will be the anticipated change in pipe length.

### General Example:

A system is installed and the design shows that there is a 100 foot straight segment of tubing between a Y-branch and a branch distribution unit. The system operates 24 hours per day. In heating, this pipe transports hot gas vapor to the indoor units at 120°F. In cooling, the same tube is a suction line returning refrigerant vapor to the outdoor unit at 40°F. Look up the copper tubing expansion at each temperature and calculate the difference.

### Vapor Line

Transporting Hot Vapor: 100 ft. pipe at 120°F = 1.40 in.  
Transporting Suction Vapor: 100 ft. pipe at 40°F = 0.40 in.  
Anticipated Change in Length: 1.40 in. – 0.40 in. = 1.00 in.

### Liquid Line

The liquid temperature remains relatively the same temperature; only the direction of flow will reverse. Therefore, no significant change in length of the liquid line is anticipated.

When creating an expansion joint, the joint depth must be a minimum of two times the joint width. Although different types of expansion arrangements are available, the data for correctly sizing an expansion loop is provided in the table “Coiled Expansion Loops and Offsets (Plan View).” Use soft copper with long radius bends on longer runs or long radius elbows for shorter pipe segments. Using the anticipated linear expansion (LE) distance calculated, look up the Expansion Loop or U-bend minimum design dimensions. If other types of expansion joints are chosen, design per ASTM B-88 Standards.

**To find the anticipated expansion value:**

1. From the table below, find the row corresponding with the actual feet of the straight pipe segment.
2. Estimate the minimum and maximum temperature of the pipe.
3. In the column showing the minimum pipe temperature, look up the anticipated expansion distance corresponding to the segment length. Do the same for the maximum pipe temperature.
4. Calculate the difference in the two expansion distance values. The result will be the change in pipe length.

Table 18: Linear Thermal Expansion of Copper Tubing in Inches.

Pipe Length <sup>1</sup>	Fluid Temperature °F																			
	35°	40°	45°	50°	55°	60°	65°	70°	75°	80°	85°	90°	95°	100°	105°	110°	115°	120°	125°	130°
10	0.04	0.04	0.05	0.06	0.06	0.07	0.08	0.08	0.09	0.09	0.10	0.10	0.11	0.11	0.11	0.12	0.13	0.14	0.15	0.15
20	0.08	0.08	0.10	0.12	0.13	0.14	0.15	0.16	0.17	0.18	0.19	0.20	0.21	0.22	0.22	0.23	0.26	0.28	0.29	0.30
30	0.12	0.12	0.15	0.18	0.20	0.21	0.23	0.24	0.26	0.27	0.29	0.30	0.32	0.33	0.32	0.35	0.39	0.42	0.44	0.45
40	0.16	0.16	0.20	0.24	0.26	0.28	0.30	0.32	0.34	0.36	0.38	0.40	0.42	0.44	0.43	0.46	0.52	0.56	0.58	0.60
50	0.20	0.20	0.25	0.30	0.33	0.35	0.38	0.40	0.43	0.45	0.48	0.50	0.53	0.55	0.54	0.58	0.65	0.70	0.73	0.75
60	0.24	0.24	0.30	0.36	0.39	0.42	0.45	0.48	0.51	0.54	0.57	0.60	0.63	0.66	0.65	0.69	0.78	0.84	0.87	0.90
70	0.28	0.28	0.35	0.42	0.46	0.49	0.53	0.56	0.60	0.63	0.67	0.70	0.74	0.77	0.76	0.81	0.91	0.98	1.02	1.05
80	0.32	0.32	0.40	0.48	0.52	0.56	0.60	0.64	0.68	0.72	0.76	0.80	0.84	0.88	0.86	0.92	1.04	1.12	1.16	1.20
90	0.36	0.36	0.45	0.54	0.59	0.63	0.68	0.72	0.77	0.81	0.86	0.90	0.95	0.99	0.97	1.04	1.17	1.26	1.31	1.35
100	0.40	0.40	0.50	0.60	0.65	0.70	0.75	0.80	0.85	0.90	0.95	1.00	1.05	1.10	1.08	1.15	1.30	1.40	1.45	1.50
120	0.48	0.48	0.60	0.72	0.78	0.84	0.90	0.96	1.02	1.08	1.14	1.20	1.26	1.32	1.30	1.38	1.56	1.68	1.74	1.80
140	0.56	0.56	0.70	0.84	0.91	0.98	1.05	1.12	1.19	1.26	1.33	1.40	1.47	1.54	1.51	1.61	1.82	1.96	2.03	2.10
160	0.64	0.64	0.80	0.96	1.04	1.12	1.20	1.28	1.36	1.44	1.52	1.60	1.68	1.76	1.73	1.84	2.08	2.24	2.32	2.40
180	0.72	0.72	0.90	1.08	1.17	1.26	1.35	1.44	1.53	1.62	1.71	1.80	1.89	1.98	1.94	2.07	2.34	2.52	2.61	2.70
200	0.80	0.80	1.00	1.20	1.30	1.40	1.50	1.60	1.70	1.80	1.90	2.00	2.10	2.20	2.16	2.30	2.60	2.80	2.90	3.00
220	0.88	0.88	1.10	1.32	1.43	1.54	1.65	1.76	1.87	1.98	2.09	2.20	2.31	2.42	2.38	2.53	2.86	3.08	3.19	3.30
240	0.96	0.96	1.20	1.44	1.56	1.68	1.80	1.92	2.04	2.16	2.28	2.40	2.52	2.64	2.59	2.76	3.12	3.36	3.48	3.60
260	1.04	1.04	1.30	1.56	1.69	1.82	1.95	2.08	2.21	2.34	2.47	2.60	2.73	2.86	2.81	2.99	3.38	3.64	3.77	3.90
280	1.12	1.12	1.40	1.68	1.82	1.96	2.10	2.24	2.38	2.52	2.66	2.80	2.94	3.08	3.02	3.22	3.64	3.92	4.06	4.20
300	1.20	1.20	1.50	1.80	1.95	2.10	2.25	2.40	2.55	2.70	2.85	3.00	3.15	3.30	3.24	3.45	3.90	4.20	4.35	4.50
320	1.28	1.28	1.60	1.92	2.08	2.24	2.40	2.56	2.72	2.88	3.04	3.20	3.36	3.52	3.46	3.68	4.16	4.48	4.64	4.80
340	1.36	1.36	1.70	2.04	2.21	2.38	2.55	2.72	2.89	3.06	3.23	3.40	3.57	3.74	3.67	3.91	4.42	4.76	4.93	5.10
360	1.44	1.44	1.80	2.16	2.34	2.52	2.70	2.88	3.06	3.24	3.42	3.60	3.78	3.96	3.89	4.14	4.68	5.04	5.22	5.40
380	1.52	1.52	1.90	2.28	2.47	2.66	2.85	3.04	3.23	3.42	3.61	3.80	3.99	4.18	4.10	4.37	4.94	5.32	5.51	5.70
400	1.60	1.60	2.00	2.40	2.60	2.80	3.00	3.20	3.40	3.60	3.80	4.00	4.20	4.40	4.32	4.60	5.20	5.60	5.80	6.00
420	1.68	1.68	2.10	2.52	2.73	2.94	3.15	3.36	3.57	3.78	3.99	4.20	4.41	4.62	4.54	4.83	5.46	5.88	6.09	6.30
440	1.76	1.76	2.20	2.64	2.86	3.08	3.30	3.52	3.74	3.96	4.18	4.40	4.62	4.84	4.75	5.06	5.72	6.16	6.38	6.60
460	1.84	1.84	2.30	2.76	2.99	3.22	3.45	3.68	3.91	4.14	4.37	4.60	4.83	5.06	4.97	5.29	5.98	6.44	6.67	6.90
480	1.92	1.92	2.40	2.88	3.12	3.36	3.60	3.84	4.08	4.32	4.56	4.80	5.04	5.28	5.18	5.52	6.24	6.72	6.96	7.20
500	2.00	2.00	2.50	3.00	3.25	3.50	3.75	4.00	4.25	4.50	4.75	5.00	5.25	5.50	5.40	5.75	6.50	7.00	7.25	7.50

<sup>1</sup>Pipe length baseline temperature = 0°F. "Expansion of Carbon, Copper and Stainless Steel Pipe," *The Engineers' Toolbox*, [www.engineeringtoolbox.com](http://www.engineeringtoolbox.com).

# COPPER EXPANSION AND CONTRACTION

Figure 24: Coiled Expansion Loops and Offsets (Plan View).

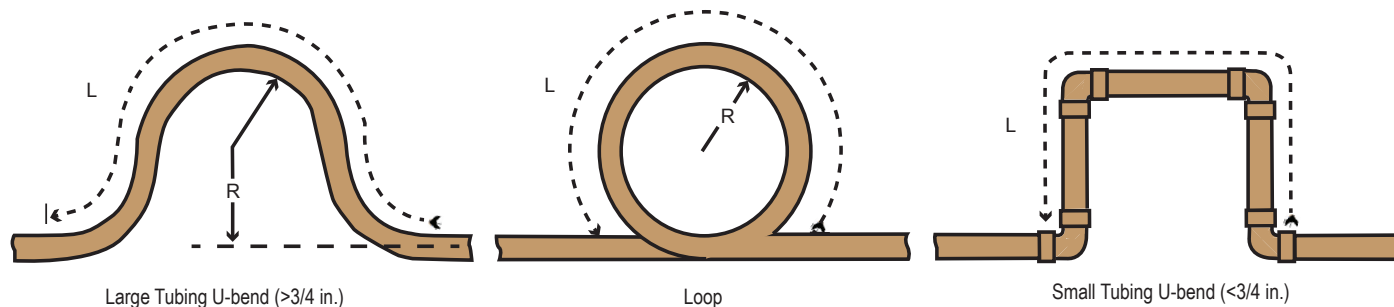

## Note:

All expansion loops and offsets must be installed in the horizontal plane to prevent the possibility of trapping oil. Loops and offsets in vertical risers must also be installed in a horizontal plane.

Table 19: Radii of Coiled Expansion Loops and Developed Lengths of Expansion Offsets.

Anticipated Linear Expansion (LE) (in.)		Nominal Tube Size (OD) inches						
		1/4	3/8	1/2	3/4	1	1-1/4	1-1/2
1/2	R <sup>1</sup>	6	7	8	9	11	12	13
	L <sup>2</sup>	38	44	50	59	67	74	80
1	R <sup>1</sup>	9	10	11	13	15	17	18
	L <sup>2</sup>	54	63	70	83	94	104	113
1-1/2	R <sup>1</sup>	11	12	14	16	18	20	22
	L <sup>2</sup>	66	77	86	101	115	127	138
2	R <sup>1</sup>	12	14	16	19	21	23	25
	L <sup>2</sup>	77	89	99	117	133	147	160
2-1/2	R <sup>1</sup>	14	16	18	21	24	26	29
	L <sup>2</sup>	86	99	111	131	149	165	179
3	R <sup>1</sup>	15	17	19	23	26	29	31
	L <sup>2</sup>	94	109	122	143	163	180	196
3-1/2	R <sup>1</sup>	16	19	21	25	28	31	34
	L <sup>2</sup>	102	117	131	155	176	195	212
4	R <sup>1</sup>	17	20	22	26	30	33	36
	L <sup>2</sup>	109	126	140	166	188	208	226

<sup>1</sup>R = Centerline Length of Pipe.

<sup>2</sup>L = Centerline Minimum Radius (inches).



## Piping Handling

Pipes used for the refrigerant piping system must include the specified thickness, and the interior must be clean.

While handling and storing, do not bend or damage the pipes, and take care not to contaminate the interior with dust, moisture, etc.

Keep Pipes Capped While Storing.

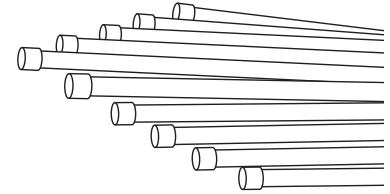

Keep refrigerant pipe dry, clean, and airtight.

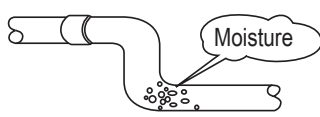
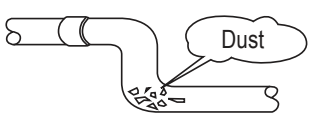
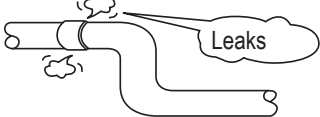
	Dry	Clean	Airtight
	No moisture should be inside the piping. 	No dust should be inside the piping. 	No leaks should occur. 
<b>Possible Problems</b>	<ul style="list-style-type: none"> <li>- Significant hydrolysis of refrigerant oil.</li> <li>- Refrigerant oil degradation.</li> <li>- Poor insulation of the compressor.</li> <li>- System does not operate properly.</li> <li>- EEVs, capillary tubes are clogged.</li> </ul>	<ul style="list-style-type: none"> <li>- Refrigerant oil degradation.</li> <li>- Poor insulation of the compressor.</li> <li>- System does not operate properly.</li> <li>- EEVs and capillary tubes become clogged.</li> </ul>	<ul style="list-style-type: none"> <li>- Refrigerant gas leaks / shortages.</li> <li>- Refrigerant oil degradation.</li> <li>- Poor insulation of the compressor.</li> <li>- System does not operate properly.</li> </ul>
<b>Solutions</b>	<ul style="list-style-type: none"> <li>- Remove moisture from the piping.</li> <li>- Piping ends should remain capped until connections are complete.</li> <li>- Do not install piping on a rainy day.</li> <li>- Connect piping properly at the unit's side.</li> <li>- Remove caps only after the piping is cut, the burrs are removed, and after passing the piping through the walls.</li> <li>- Evacuate system to a minimum of 500 microns and insure the vacuum holds at that level for 1 hour.</li> </ul>	<ul style="list-style-type: none"> <li>- Remove dust from the piping.</li> <li>- Piping ends should remain capped until connections are complete.</li> <li>- Connect piping properly at the side of the unit.</li> <li>- Remove caps only after the piping is cut and burrs are removed.</li> <li>- Retain the cap on the piping when passing it through walls, etc.</li> </ul>	<ul style="list-style-type: none"> <li>- Test system for air tightness.</li> <li>- Perform brazing procedures that comply with all applicable standards.</li> <li>- Perform flaring procedures that comply with all applicable standards.</li> <li>- Perform flanging procedures that comply with all applicable standards.</li> <li>- Ensure that refrigerant lines are pressure tested to 550 psig and hold for 24 hours.</li> </ul>



Proper system operation depends on the installer using utmost care while assembling the piping system. The following pages are an overview of best practices when installing the refrigerant piping system.

## Note:

*LG Electronics U.S.A., Inc., is not responsible for any piping calculations, refrigerant leaks, degradation of performance, any other potential problems or damages caused by the interconnecting piping, their joint connections, isolation valves, or introduced debris inside the piping system.*

## ⊘ No Pipe Size Substitutions

Use only the pipe size selected by the LATS HVAC pipe system design software. Using a different size is prohibited and will result in a system malfunction or failure to work at all.

## ⊘ No In-line Refrigeration Components

Components such as oil traps, solenoid valves, filter-driers, sight glasses, tee fittings, and other after-market accessories are ⊘ not permitted on the refrigerant piping system between the outdoor units and the indoor / heat recovery units. LG HVAC systems are provided with redundant systems that make sure oil is properly returned to the compressor. Sight-glasses and solenoid valves will cause vapor to form in the liquid stream. Over time, driers will deteriorate and introduce debris into the system. The designer and installer must verify the refrigerant piping system is free of traps, sagging pipes, sight glasses, filter driers, etc.

## Field-Provided Isolation Ball Valves

LG maintains a neutral position on using isolation valves in LG HVAC refrigerant piping systems. LG does not endorse any manufacturer of isolation valves. It is recognized that installing isolation valves will simplify future maintenance requirements, and, if used, considerations must be taken including, but not limited to, the following:

- Pressure drops for any component used, including isolation valves, must be known in equivalent pipe length and calculated into the total and segment equivalent piping lengths and compared to product design limitations.
- In all cases, materials must be suitable for the application and any applicable codes, including, but not limited to, diameter and wall thickness continuity per ACR standards.

Failure to do so will cause significant performance degradation. Proper leak checks must be performed. Using isolation valves does not automatically void any LG product warranty, however, a limited warranty will be voided in whole or part must any field supplied accessory fail in any way that causes product failure.

## Using Elbows

Field-supplied elbows are allowed if they are long radius and designed for use with R410A refrigerant. The designer and installer, however, must be cautious with the quantity and size of fittings used, and must account for the additional pressure losses in equivalent pipe length calculation for each branch. The equivalent pipe length of each elbow must be added to each pipe segment in the LATS program.

## Pipe Bends

When bending soft copper, use long radius bends. Refer to the “Radii of Coiled Expansion Loops and Developed Lengths of Expansion Offsets” table for minimum radius specifications.

## Obstacles

When an obstacle, such as an I-beam or concrete T, is in the path of the planned refrigerant pipe run, it is best practice to route the pipe over the obstacle. If adequate space is not available to route the pipe over the obstacle, then route the pipe under the obstacle. In either case, it is imperative the length of the horizontal section of pipe above or below the obstacle be a minimum of three (3) times the longest vertical rise (or fall) at either end of the segment.

Figure 25: Installing Piping Above and Below an Obstacle.

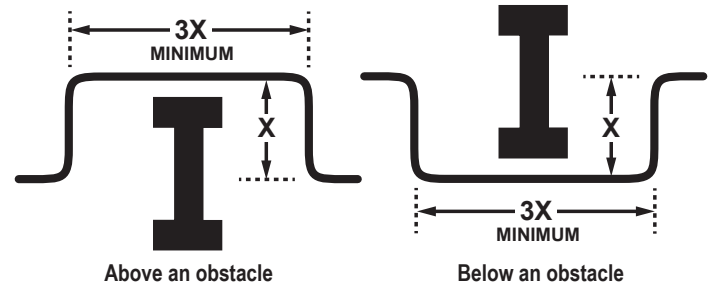

## Pipe Supports

A properly installed pipe system must be adequately supported to avoid pipe sagging. Sagging pipes become oil traps that lead to equipment malfunction.

Pipe supports must never touch the pipe wall; supports must be installed outside (around) the primary pipe insulation jacket. Insulate the pipe first because pipe supports must be installed outside (around) the primary pipe insulation jacket. Clevis hangers must be used with shields between the hangers and insulation. Field provided pipe supports must be designed to meet local codes. If allowed by code, use fiber straps or split-ring hangers suspended from the ceiling on all-thread rods (fiber straps or split ring hangers can be used as long as they do not compress the pipe insulation). Place a second layer of insulation over the pipe insulation jacket to prevent chafing and compression of the primary insulation in the confines of the support clamp.

A properly installed pipe system will have sufficient supports to avoid pipes from sagging during the life of the system. As necessary, place supports closer for segments where potential sagging could occur. Maximum spacing of pipe supports must meet local codes. If local codes do not specify pipe support spacing, pipe must be supported:

- Maximum of five (5) feet on center for straight segments of pipe up to 3/4 inches outside diameter size.
- Maximum of six (6) feet on center for pipe up to one (1) inch outside diameter size.
- Maximum of eight (8) feet on center for pipe up to two (2) inches outside diameter size.

Wherever the pipe changes direction, place a hanger within twelve (12) inches on one side and within twelve (12) to nineteen (19) inches of the bend on the other side. Support piping at indoor units, Y-branch, and Header fittings as shown.

Figure 26: Pipe Hanger Details.

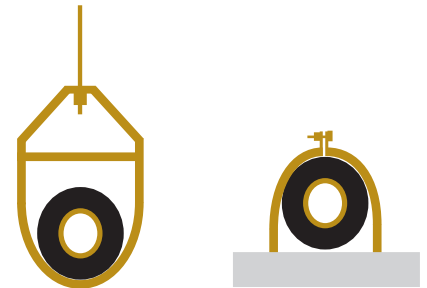

### Note:

Use a 4" + long sheet curved sheet metal saddles between hanger bracket and insulation to promote linear expansion/contraction.

Figure 27: Typical Pipe Support Location—Change in Pipe Direction.

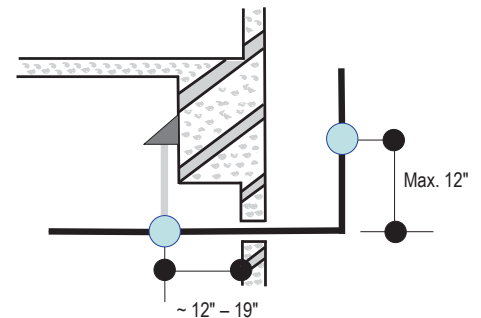

Figure 28: Pipe Support at Indoor Unit.

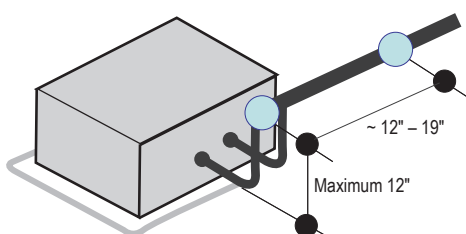

Figure 29: Pipe Support at Y-branch Fitting.

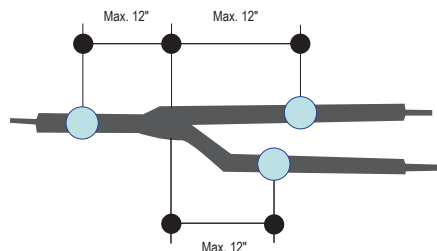
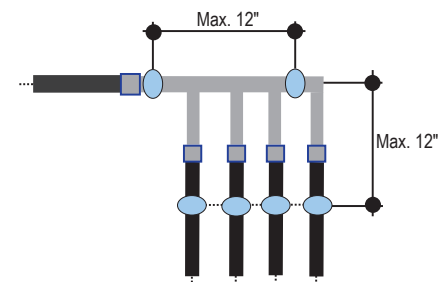

Figure 30: Pipe Support at Header Fitting.



## Examples of Supports

Figure 31: U-Bolt Support with Insulation.

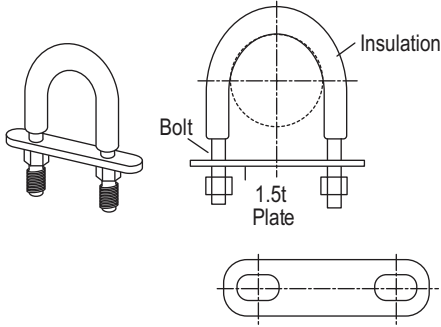

Figure 32: O-Ring Support with Insulation.

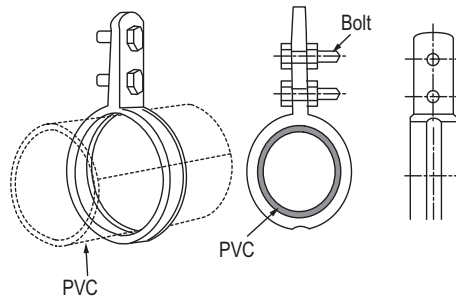
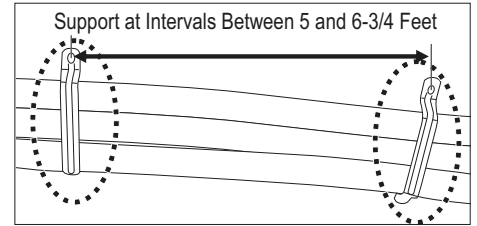

Figure 33: Saddle-Type Support.



*Do not compress the insulation with the saddle-type support. If the insulation is compressed, it will tear open and allow condensation to generate during product operation.*

Figure 34: U-Bolt Support with an Insulated Pipe.

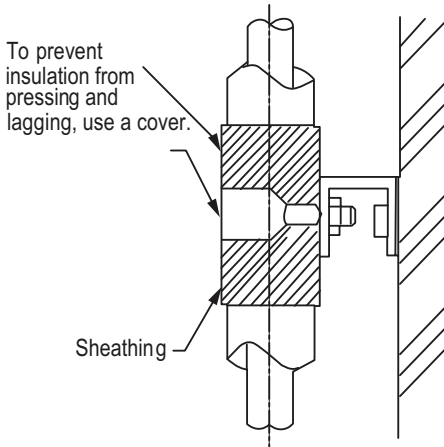

Figure 35: O-Ring Band Support with an Insulated Pipe.

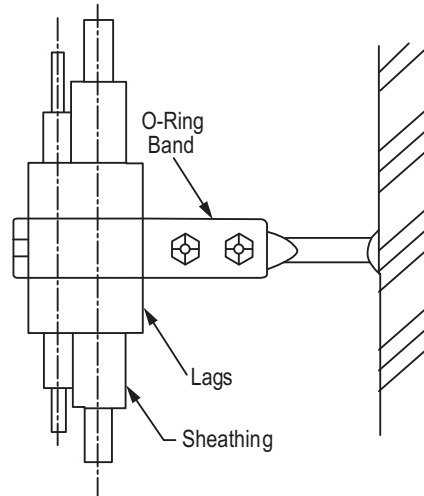

Figure 36: One-Point Down-Stop Support (>441 lbs.).

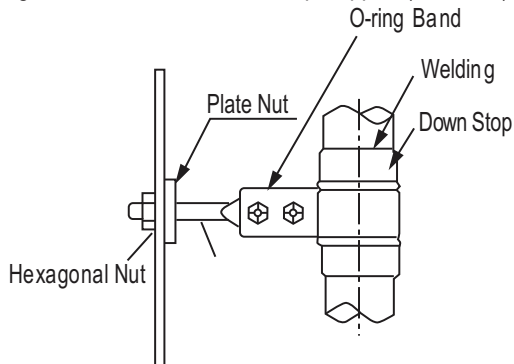
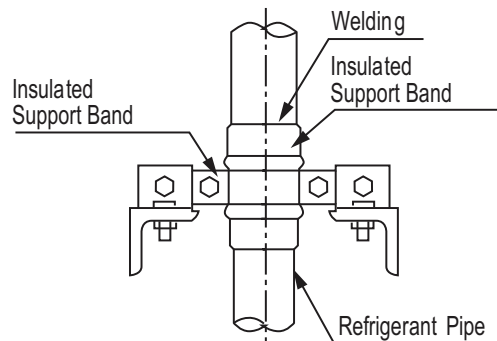

Figure 37: Two-Point Down-Stop Support.



## Pipe Sleeves at Penetrations

LG recommends that all pipe penetrations through walls, floors, and pipes buried underground be properly insulated and routed through an appropriate wall sleeve of sufficient size to prevent compression of refrigerant pipe insulation and promote free movement of the pipe within the sleeve. Use 4"+ curved sheet metal saddles between the bottom surface of the pipe and the bottom surface of the penetration.

Figure 38: Pipe Sleeve Options.

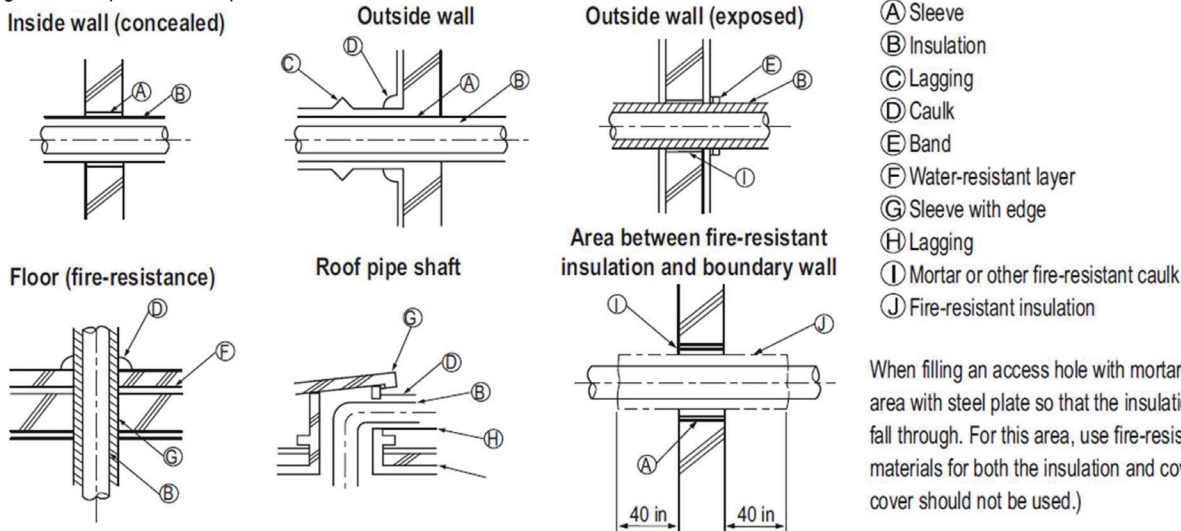

**Note:**

Diameter of penetrations must be determined by pipe diameter plus the thickness of the insulation.

## Underground Refrigerant Piping

Refrigerant pipe installed underground must be routed inside a vapor tight protective sleeve to prevent insulation deterioration and water infiltration. Refrigerant pipe installed inside underground casing must be continuous without any joints. Underground refrigerant pipe must be located at a level **below the frost line**.

Table 20: Utility Conduit Sizes.

Liquid Pipe <sup>1</sup>	Vapor Pipe <sup>1</sup>			
	3/8 (2.0 <sup>2,5</sup> )	1/2 (2.0 <sup>2,5</sup> )	5/8 (2-1/8 <sup>2,5</sup> )	3/4 (2-1/4 <sup>2,5</sup> )
1/4 (1.0) <sup>3</sup>	4	4	4	4
3/8 (1-1/8) <sup>3</sup>	4	4	4	5
1/2 (1-1/2) <sup>4</sup>	5	5	5	5
5/8 (1-5/8) <sup>4</sup>	5	5	5	5
3/4 (1-3/4) <sup>4</sup>	5	5	5	5

<sup>1</sup>OD pipe diameter in inches; Values in parenthesis ( ) indicate OD of pipe with insulation jacket.

<sup>2</sup>Diameter of pipe with insulation. Thickness of pipe insulation is typical. Actual required thickness will vary based on surrounding ambient conditions and must be calculated and specified by the design engineer.

<sup>3</sup>Insulation thickness (value in parenthesis) = 3/8 inch.

<sup>4</sup>Insulation thickness (value in parenthesis) = 1 inch.

<sup>5</sup>Insulation thickness (value in parenthesis) = 3/4 inch.

Figure 39: Typical Arrangement of Refrigerant Pipe and Cable(s) in a Utility Conduit.

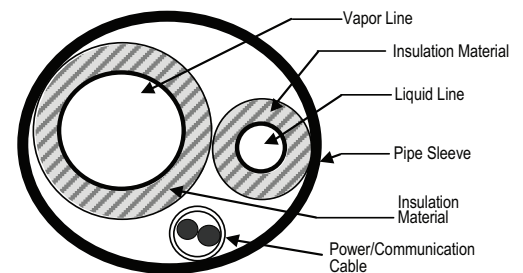

**Note:**

Provide expansion joints in long pipe segments and place in an accessible conduit box for inspection. Use galvanized curved sheet metal saddles at all mounting points. Pipe must be allowed to move freely linearly.

## Flaring and Brazing Procedures

One of the main causes of refrigerant leaks is a defective connection. For LG HVAC systems, the installer needs to know how perform both flared and brazed connections successfully.

### Note:

- During installation, it is imperative to keep the piping system free of contaminants and debris such as copper burrs, slag, or carbon dust.
- ⚠ Do not use kinked pipe caused by excessive bending in one specific area on its length.

## Flaring Procedure

### Note:

When selecting flare fittings, always use a 45° fitting rated for use with high pressure refrigerant R410A. Selected fittings must also comply with local, state, or federal standards.

#### 1. Cut the pipe to length.

- Measure the distance between the indoor unit and the outdoor unit.
- Cut the pipes a little longer than measured distance.

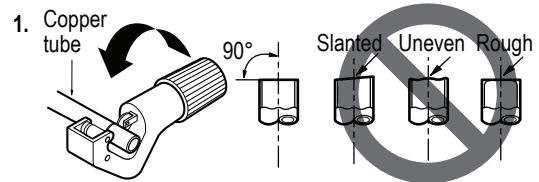

#### 2A. Remove the burrs.

- Completely remove all burrs from pipe ends.
- When removing burrs, point the end of the copper pipe down to avoid introducing foreign materials in the pipe.

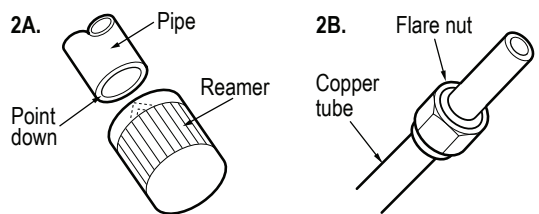

#### 2B. Slide the flare nut onto the copper tube.

#### 3. Flaring the pipe end.

- Use the proper size flaring tool to finish flared connections as shown.
- ALWAYS create a 45° flare when working with R410A.

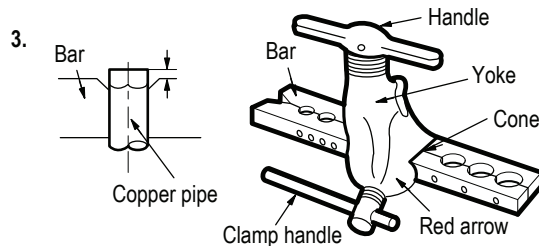

#### 4. Carefully inspect the flared pipe end.

- Compare the geometry with the figure to the right
- If the flare is defective, cut it off and re-do procedure.
- If flare looks good, blow the pipe clean with dry nitrogen.

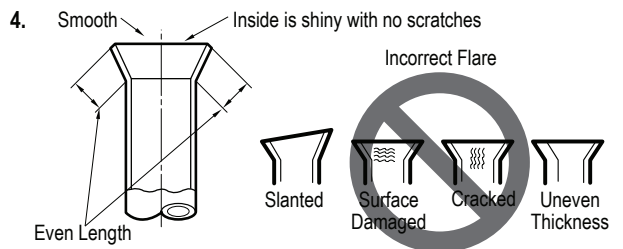

Dimensions of the Flare.

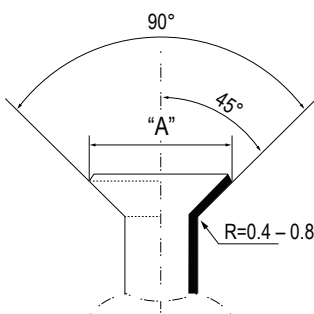

Flared Connection Dimensions / Tightening Torque.

Pipe Size (in. O.D.)	Outside Diameter (mm)	"A" Dimension (mm [in.])
1/4	6.35	~ 9.1 (11/32 - 23/64)
3/8	9.52	~ 13.2 (1/2 - 33/64)
1/2	12.7	~ 16.6 (41/64 - 21/32)
5/8	15.88	~ 19.7 (49/64 - 25/32)
3/4	19.05	-

## Tightening the Flare Nuts

Tightening Torque for Flare Nuts.

Pipe Size (in. O.D.)	Outside Diameter (mm)	Tightening Torque (ft-lbs.)
1/4	6.35	13.0 - 18.0
3/8	9.52	24.6 - 30.4
1/2	12.7	39.8 - 47.7
5/8	15.88	45.4 - 59.3
3/4	19.05	71.5 - 87.5

- When connecting the flare nuts, coat the flare (outside only) with polyvinyl ether (PVE) refrigeration oil only.

### Note:

- ⊘ Do not use polyolyester (POE) or any other type of mineral oil as a thread lubricant. These lubricants are not compatible with the PVE oil used in this system and create oil sludge leading to equipment damage and system malfunction.
  - ⊘ Do not add any contaminants inside the refrigerant piping.
- Initially hand tighten the flare nuts using three (3) or four (4) turns.
  - To finish tightening the flare nuts, use both a torque wrench and a backup wrench.
  - After all the piping has been connected and the caps have been tightened, check for refrigerant gas leaks.

## Loosening the Flare Nuts

Always use two (2) wrenches to loosen the flare nuts.

## Brazing Procedure

### ⚠ WARNING

⊘ Do not braze in an enclosed location. ⊘ Do not allow the refrigerant to leak during brazing. Always test for gas leaks before and after brazing. If the refrigerant combusts, it generates a toxic gas that will cause physical injury or death.

### Note:

Braze the pipes to the service valve pipe stub of the outdoor unit.

- All joints are brazed in the field. LG HVAC refrigeration system components contain very small capillary tubes, small orifices, electronic expansion valves, oil separators, and heat exchangers that can easily become blocked. Proper system operation depends on the installer using best practices and utmost care while assembling the piping system.
- Store pipe stock in a dry place; keep stored pipe capped and clean.
- Blow clean all pipe sections with dry nitrogen prior to assembly.
- Use adapters to assemble different sizes of pipe.
- Always use a non-oxidizing material for brazing. ⊘ Do not use flux, soft solder, or anti-oxidant agents. If the proper material is not used, oxidized film will accumulate and clog or damage the compressors. Flux can harm the copper piping or refrigerant oil.
- Use a tubing cutter, ⊘ do not use a saw to cut pipe. De-bur and clean all cuts before assembly.
- Brazing joints:
  - Use a dry nitrogen purge operating at a minimum pressure of three (3) psig and maintain a steady flow.
  - Use a 15% silver phosphorous copper brazing alloy to avoid overheating and produce good flow.
  - Protect isolation valves, electronic expansion valves, and other heat-sensitive control components from excessive heat with a wet rag or heat barrier spray.

Figure 40: Refrigerant Pipe Brazing.

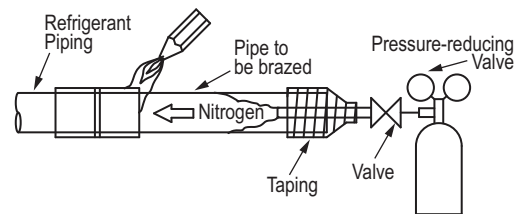



# INSTALLING MULTI F WITH LGRED SYSTEMS

MULTI F WITH LGRED<sup>®</sup>  
MULTI F MAX

## Multi F with LGRED Outdoor Unit to Indoor Unit Piping Connections

### Note:

#### ⊘ Avoid Pipe Damage

- When routing field-provided piping, ⊘ avoid damaging the outdoor unit from excessive vibration.
- Properly insulate the liquid and gas lines separately up to the point of connection at the unit frame.
- See table below for Multi F with LGRED outdoor unit connection types.

- ⊘ Correctly route the piping so it does not make contact with mounting bolts. Allow room for field installation.

Table 21: Multi F with LGRED Outdoor Unit Piping Connections.

Outdoor Unit Piping Connections	LMU180HHV	LMU240HHV	LMU300HHV
Liquid Line Connection (in., OD) x Qty.	Ø1/4 x 2	Ø1/4 x 3	Ø1/4 x 4
Vapor Line Connection (in., OD) x Qty.	Ø3/8 x 2	Ø3/8 x 3	Ø3/8 x 4

Figure 41: Multi F with LGRED Outdoor Unit Refrigerant Pipe Connections (LMU360HHV shown as example).

Multi F with LGRED Outdoor Unit (18, 24, 30kBtu/h)

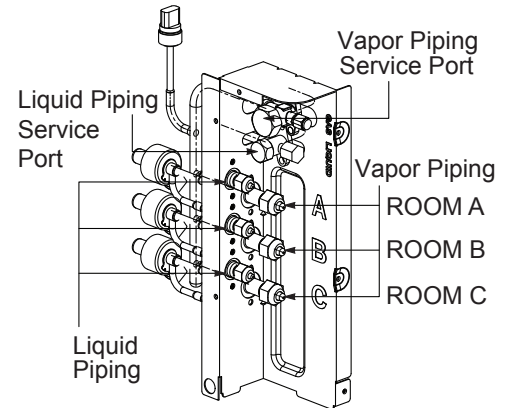

Table 22: Indoor Unit Pipe Sizes.

Indoor Unit Capacity	Vapor Line Piping Size (in., OD)	Liquid Line Piping Size (in., OD)
7,000 Btu/h	Ø3/8	Ø1/4
9,000 Btu/h		
12,000 Btu/h		
15,000 Btu/h		
15,000 Btu/h: Console; 18,000 Btu/h	Ø1/2	
24,000 Btu/h		

Table 24: Indoor Unit Piping Connections.

Indoor Unit Capacity	Vapor Line Conn. (in., OD)	Liquid Line Conn. (in., OD)
7,000 Btu/h	Ø3/8	Ø1/4
9,000 Btu/h		
12,000 Btu/h		
15,000 Btu/h		
18,000 Btu/h: Wall-Mounted	Ø5/8	Ø3/8
15,000 Btu/h: Console; 18,000 Btu/h: Low Static Duct, Four-Way Cassette	Ø1/2	Ø1/4
24,000 Btu/h	Ø1/2	Ø1/4

### Note:

Connection sockets (included as a factory-supplied accessory with the indoor units) will need to be used when piping the indoor units to the outdoor unit. See tables above and below for indoor unit piping connection and connection socket dimensions. See the follow page for the connection socket installation procedure.

Table 23: Connection Socket Dimensions.

Indoor Unit Capacity	Vapor (in., OD)		Liquid (in., OD)	
	A	B	A	B
18,000 Btu/h: Wall-Mounted	Ø3/8 → Ø1/2, Ø1/2 → Ø5/8		Ø1/4 → Ø3/8	
15,000 Btu/h: Console; 18,000 Btu/h: Low Static Duct, Four-Way Cassette	Ø3/8 → Ø1/2		N/A	
24,000 Btu/h	Ø3/8 → Ø1/2		N/A	



## Installing Field Piping to the Outdoor Unit Piping Connections

1. Verify the outdoor unit service ports are closed.
2. Remove the caps on the outdoor unit piping connections.
3. Connect the gas piping first to ROOM A, then to ROOM B, then to ROOM C, in that order. Number of connections will differ depending on outdoor unit.
4. Tighten each gas piping connection individually following the "Tightening the Flare Nuts" procedure below.
5. Connect the liquid piping first to ROOM A, then to ROOM B, then to ROOM C, in that order. Number of connections will differ depending on outdoor unit.
6. Tighten each liquid piping connection individually following the "Tightening the Flare Nuts" procedure below.

Figure 42: Close Up of the Field Piping to the Outdoor Unit Piping Connection.

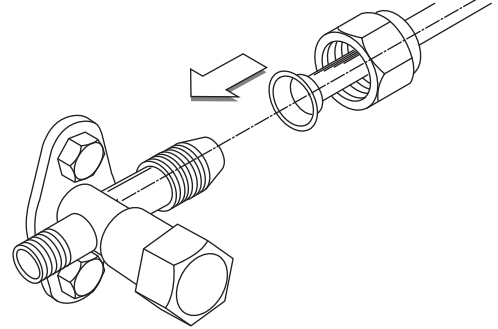

## Tightening the Flare Nuts

Tightening Torque for Flare Nuts.

Pipe Size (in. O.D.)	Outside Diameter (mm)	Tightening Torque (ft.-lbs.)
1/4	6.35	13.0 - 18.0
3/8	9.52	24.6 - 30.4
1/2	12.7	39.8 - 47.7
5/8	15.88	45.4 - 59.3
3/4	19.05	71.5 - 87.5

1. When connecting the flare nuts, coat the flare (outside only) with polyvinyl ether (PVE) refrigeration oil only.

## Note:

- ⊘ Do not use polyolyster (POE) or any other type of mineral oil as a thread lubricant. These lubricants are not compatible with the PVE oil used in this system and create oil sludge leading to equipment damage and system malfunction.
- ⊘ Do not add any contaminants inside the refrigerant piping.

2. Initially hand tighten the flare nuts using three (3) or four (4) turns.
3. To finish tightening the flare nuts, use both a torque wrench and a backup wrench.
4. After all the piping has been connected and the caps have been tightened, check for refrigerant gas leaks.

## Using the Connection Socket

Some indoor units require the use of a connection socket when piping the indoor units to the outdoor unit. (See previous page for information.) The connection sockets are included as a factory-supplied accessory with the indoor units. To install:

1. Align the center of the piping sections as seen in the diagrams at right and below.
2. Follow the "Tightening the Flare Nuts" procedure above.

Figure 43: Connection Socket Installation.

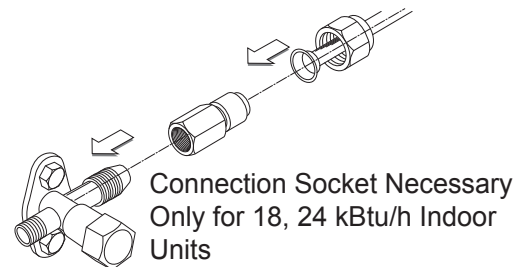

Figure 44: Connection Socket Diagram, External View.

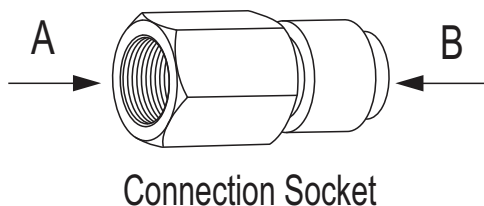
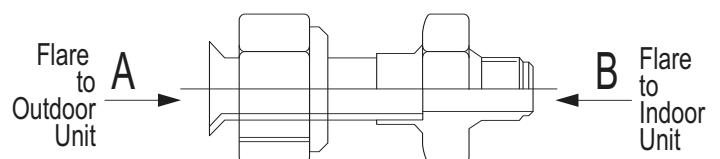

Figure 45: Connection Socket Diagram, Internal View.



# INSTALLING MULTI F MAX WITH LGRED SYSTEMS

MULTI F WITH LGRED<sup>®</sup>  
MULTI F MAX

## Multi F MAX with LGRED Refrigerant Piping Connections / Piping Routes

For Multi F MAX with LGRED outdoor units, piping can be installed in one of four directions: front, rear, right, and bottom. Whatever direction is chosen, plug the access holes with field-provided putty or insulation to fill all gaps.

If the piping is installed in the bottom direction, the access hole of the base pan must be knocked out before piping work begins.

Figure 46: Multi F MAX with LGRED Outdoor Unit Refrigerant Piping Connection Options.

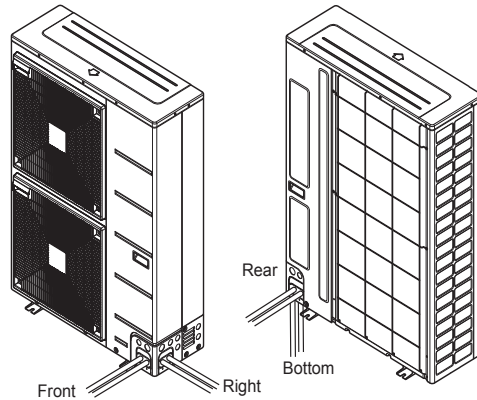

Figure 47: Removing the Base Pan Knock Out Hole.

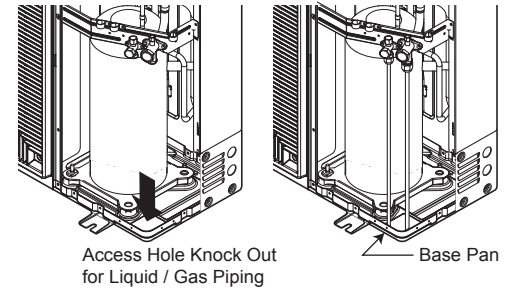
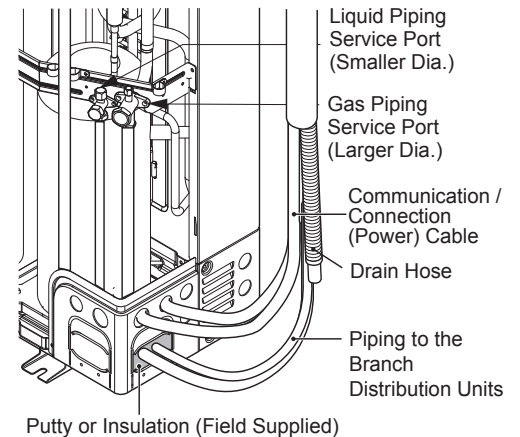

Figure 48: Filling Access Holes in the Outdoor Units.



### ⚠ WARNING

Insects or small animals entering the outdoor unit will cause a short circuit in the electrical box, which will lead to fire, electric shock, physical injury, or death.

### Note:

Insects or small animals entering the outdoor unit will cause a short circuit in the electrical box, which will lead to unit failure.

## Multi F MAX with LGRED Outdoor Unit System Piping Connections

### Note:

#### ⊘ Avoid Pipe Damage

- When routing field-provided piping, ⊘ avoid damaging the outdoor unit from excessive vibration.
- Properly insulate the liquid and gas lines separately up to the point of connection at the unit frame.
- See table below for Multi F MAX outdoor unit connection types.

- ⊘ Correctly route the piping so it does not make contact with mounting bolts. Allow room for field installation.

Table 25: Multi F MAX with LGRED Outdoor Unit Piping Connections.

Outdoor Unit Piping Connections	LMU360HHV, LMU420HHV
Liquid Line Connection (in., OD) x Qty.	Ø3/8 x 1
Vapor Line Connection (in., OD) x Qty.	Ø3/4 x 1

Figure 49: Multi F MAX with LGRED Outdoor Unit Refrigerant Pipe Connections.

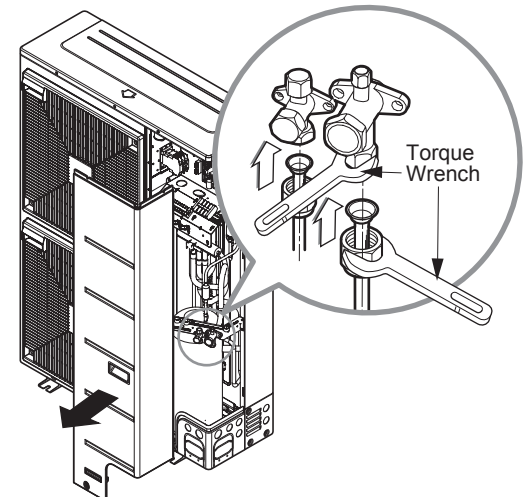

## Branch Distribution to Indoor Unit Piping Connections

- Install indoor unit liquid and vapor refrigerant pipes (and connection wiring) to the appropriate branch distribution ports.
- Clearly note on the indoor unit's refrigerant piping (liquid, vapor) which branch distribution port it is connected to (A, B, C, D).

Table 26: Branch Distribution Unit Piping Connections.

Branch Distribution Unit	Refrigerant Connections Pipe Size (in.)		Connectible Indoor Unit Capacity (Btu/h)
	Liquid	Vapor	
PMBD3620	Ø1/4 x 2	Ø3/8 x 2	7,000, 9,000, 12,000, 15,000, 18,000, 24,000
PMBD3630	Ø1/4 x 3	Ø3/8 x 3	7,000, 9,000, 12,000, 15,000, 18,000, 24,000
PMBD3640	Ø1/4 x 4	Ø3/8 x 4	7,000, 9,000, 12,000, 15,000, 18,000, 24,000
PMBD3641	Ø1/4 x 4	Ø3/8 x 3	7,000, 9,000, 12,000, 15,000, 18,000, 24,000 (A, B, C)
		Ø1/2 x 1	24,000, 36,000 (D)

Figure 51: Branch Distribution Ports to Indoor Units -- Side View.

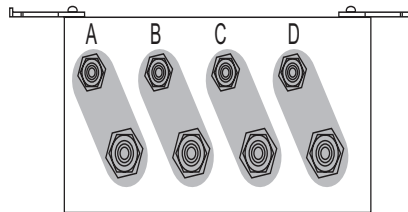
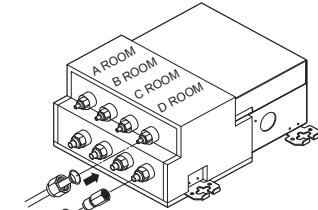

Figure 50: Branch Distribution Piping Connections.

Multi F MAX with LGRED Outdoor Units (36, 42 kBtu/h)

(Branch Distribution Unit: PMBD3640)



(Only for 18, 24 kBtu/h Indoor Units)

(Branch Distribution Unit: PMBD3641)

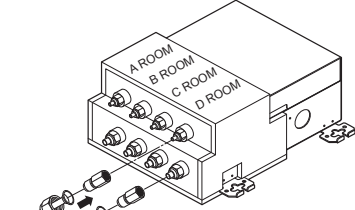

(Only for 36 kBtu/h Indoor Units to Connect to "D ROOM")

Table 27: Indoor Unit Pipe Sizes.

Indoor Unit Capacity	Vapor Line Piping Size (in., OD)	Liquid Line Piping Size (in., OD)
7,000 Btu/h	Ø3/8	Ø1/4
9,000 Btu/h		
12,000 Btu/h		
15,000 Btu/h		
15,000 Btu/h: Console; 18,000 Btu/h	Ø1/2	Ø3/8
24,000 Btu/h		
36,000 Btu/h	Ø5/8	Ø3/8

Table 28: Indoor Unit Piping Connections.

Indoor Unit Capacity	Vapor Line Conn. (in., OD)	Liquid Line Conn. (in., OD)
7,000 Btu/h	Ø3/8	Ø1/4
9,000 Btu/h		
12,000 Btu/h		
15,000 Btu/h		
18,000 Btu/h: Wall-Mounted	Ø5/8	Ø3/8
15,000 Btu/h: Console; 18,000 Btu/h: Low Static Duct, Four-Way Cassette	Ø1/2	Ø1/4
24,000 Btu/h	Ø1/2	Ø1/4
36,000 Btu/h	Ø5/8	Ø3/8

## Note:

Connection sockets (included as a factory-supplied accessory with the indoor units) will need to be used when piping the indoor units to the branch distribution unit. The connection sockets for 36k indoor units are factory supplied with the branch distribution units. See tables above and below for indoor unit piping connection and connection socket dimensions. See the follow page for the connection socket installation procedure.

Table 29: Connection Socket Dimensions.

Indoor Unit Capacity	Vapor (in., OD)		Liquid (in., OD)	
	A	B	A	B
18,000 Btu/h: Wall-Mounted	Ø3/8 → Ø1/2, Ø1/2 → Ø5/8		Ø1/4 → Ø3/8	
15,000 Btu/h: Console; 18,000 Btu/h: Low Static Duct, Four-Way Cassette	Ø3/8 → Ø1/2		N/A	
24,000 Btu/h	Ø3/8 → Ø1/2		N/A	
36,000 Btu/h	Ø1/2 → Ø5/8		Ø1/4 → Ø3/8	

# INSTALLING MULTI F MAX WITH LGRED SYSTEMS

MULTI F WITH LGRED<sup>®</sup>  
MULTI F MAX

## Installing Field Piping to the Branch Distribution Unit Piping Connections

1. Remove any caps, etc., that could be on the branch distribution unit.
2. Tighten each piping connection individually following the "Tightening the Flare Nuts" procedure below.
3. When all piping installation has been completed, perform the triple leak / pressure and evacuation tests (see the Final Installation Procedures Section), verify that the system does not have any leaks, and then fully insulate all joints / connections.

## Using the Connection Socket

Some indoor units require the use of a connection socket when piping the indoor units to the branch distribution unit. (See previous page and below for information.) The connection sockets are included as a factory-supplied accessory with the indoor units, or in the case of the 36k indoor unit, it is factory supplied with the branch distribution units. To install:

1. Remove any caps, etc., that could be on the branch distribution unit.
2. Align the center of the piping sections as seen in the diagram at right.
3. Tighten each piping connection individually following the "Tightening the Flare Nuts" procedure below.
4. When all piping installation has been completed, perform the triple leak / pressure and evacuation tests (see the Final Installation Procedures Section), verify that the system does not have any leaks, and then fully insulate all joints / connections.

Figure 53: Connection Socket Diagram, External View.

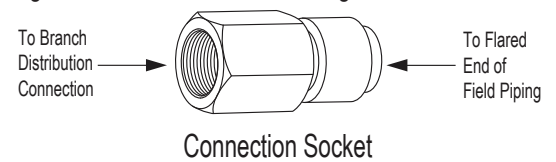
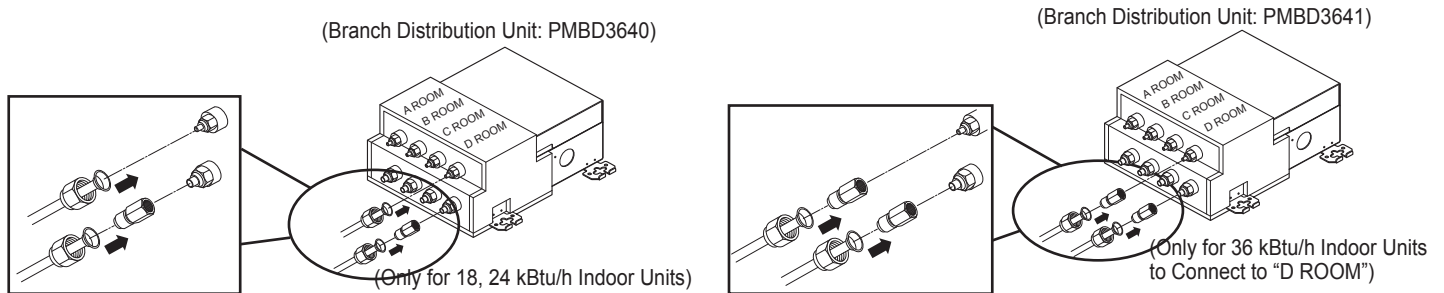

Figure 52: Close Up of Branch Distribution to Indoor Unit Piping Connections.



## Tightening the Flare Nuts

Tightening Torque for Flare Nuts.

Pipe Size (in. O.D.)	Outside Diameter (mm)	Tightening Torque (ft-lbs.)
1/4	6.35	13.0 - 18.0
3/8	9.52	24.6 - 30.4
1/2	12.7	39.8 - 47.7
5/8	15.88	45.4 - 59.3
3/4	19.05	71.5 - 87.5

1. When connecting the flare nuts, coat the flare (outside only) with polyvinyl ether (PVE) refrigeration oil only.

## Note:

- ⊘ Do not use polyolyester (POE) or any other type of mineral oil as a thread lubricant. These lubricants are not compatible with the PVE oil used in this system and create oil sludge leading to equipment damage and system malfunction.
  - ⊘ Do not add any contaminants inside the refrigerant piping.
2. Initially hand tighten the flare nuts using three (3) or four (4) turns.
  3. To finish tightening the flare nuts, use both a torque wrench and a backup wrench.
  4. After all the piping has been connected and the caps have been tightened, check for refrigerant gas leaks.

Figure 54: Socket Connection.

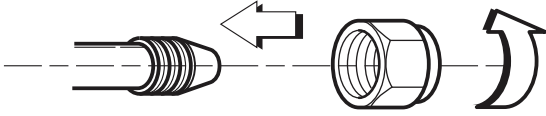
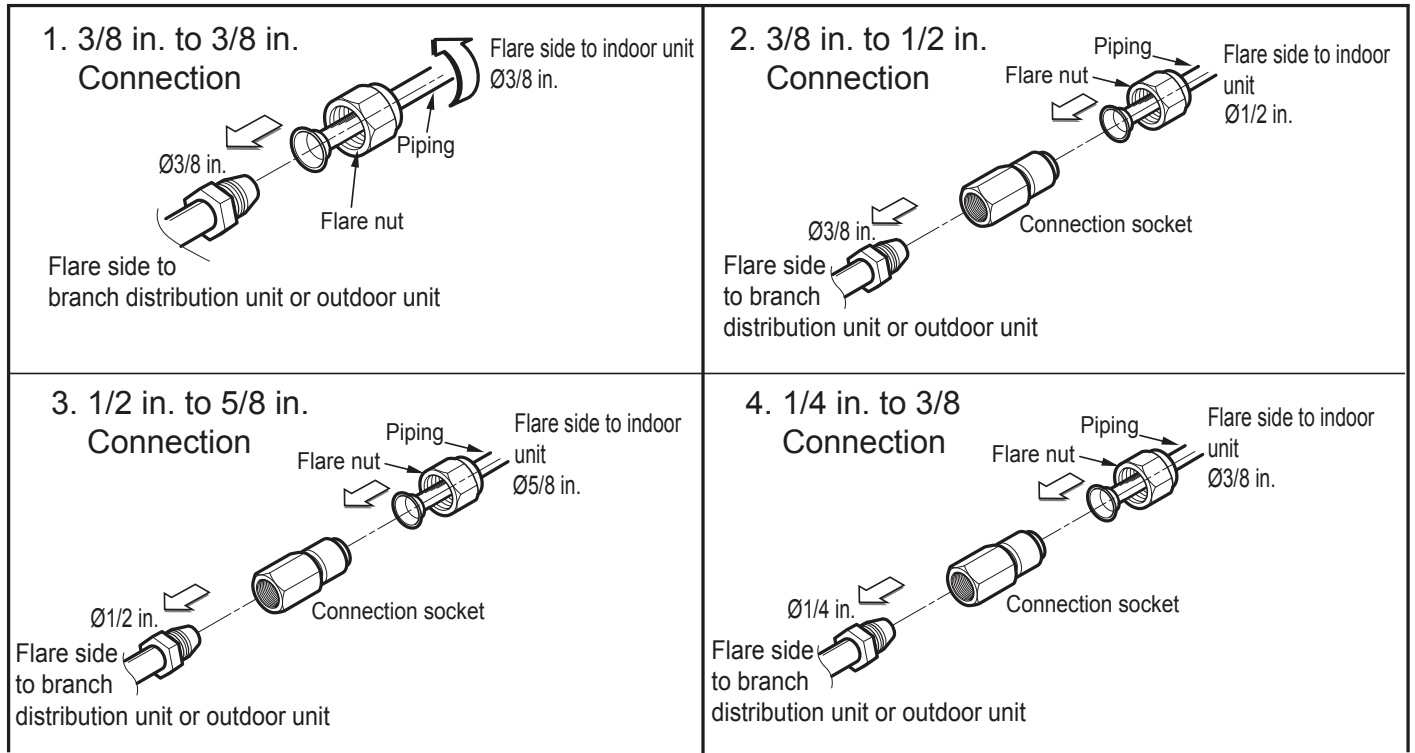

Figure 55: Possible Outdoor Unit or Branch Distribution Unit to Indoor Unit Connections.





# INSTALLING MULTI F MAX WITH LGRED SYSTEMS

MULTI F WITH LGRED<sup>®</sup>  
MULTI F MAX

MULTI F / MULTI F MAX with LGRED Outdoor Unit Installation Manual

## Multi F MAX with LGRED Y-Branch Kit PMBL5620

The LG-supplied Y-Branch kit PMBL5620 MUST be used when installing two (2) branch distribution units in parallel on one (1) Multi F MAX with LGRED system. ⚠ Field-supplied fittings are not permitted. Each Y-Branch kit includes two (2) Y-branches (one for the liquid line and one for the vapor line) and insulation covers.

Y-branches can be installed in horizontal or vertical configurations. When installed vertically, position the Y-branch so the straight through leg is  $\pm 3^\circ$  of plumb. When installed horizontally, position the Y-branch so the take-off leg is level and shares the same horizontal plane as the straight-through leg  $\pm 5^\circ$  rotation.

Y-branches must be properly installed following instructions in the applicable LG manual. Y-branches must always be installed with the single port facing the outdoor unit and the two-port end facing the branch distribution units. ⚠ Do not install Y-branches backwards as refrigerant flow cannot make U-turns. The Y-branch kit must be located at least three (3) feet from the outdoor unit. Provide a minimum of 20 inches between a Y-branch and the branch distribution unit.

When a Y-branch is located in a pipe chase or other concealed space, access doors must be provided for inspection access.

The equivalent pipe length of each Y-branch (1.6') must be added to the main pipe segment entered into LATS piping design software.

### Note:

- Design pressure is 551 psig.
- All dimensions in inches. Tolerance  $\pm 1/4$  inch.
- Images are not to scale.

Figure 58: Horizontal Configuration End View.

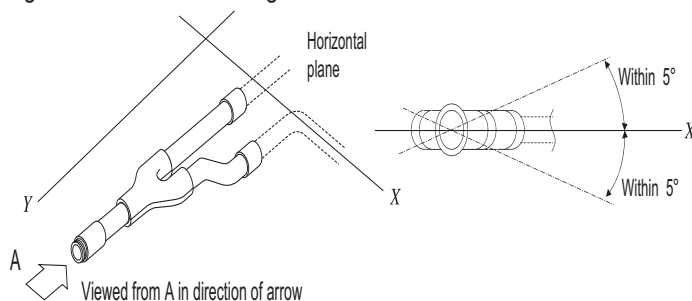

Figure 56: Y-Branch Port Identifier Diagram.

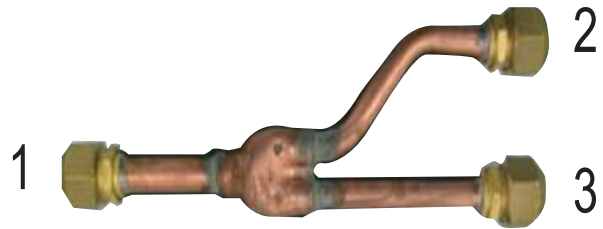
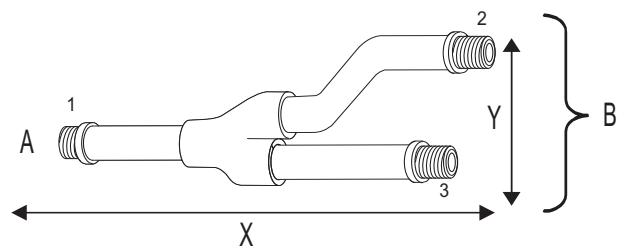

Figure 57: Y-Branch Dimensions Diagram.



A = To Outdoor Unit

B = To Branch Distribution Unit

Table 30: Multi F MAX with LGRED Y-Branch Specifications.

Model	Y-Branch Type	Port Identifier (inch)		
		1	2	3
PMBL5620	Liquid	$\text{\O}3/8$	$\text{\O}3/8$	$\text{\O}3/8$
	Vapor	$\text{\O}3/4$	$\text{\O}3/4$	$\text{\O}3/4$
	Y-Branch Type	Dimensions (inch)		
		X	Y	
	Liquid	13.80	3.24	
	Vapor	12.48	3.02	

Figure 59: Y-branch Installation Alignment Specification.

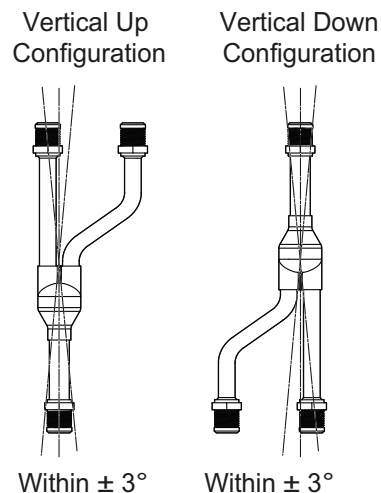



## Bundling

If a conduit or piping set cover is not used on the connection from the outdoor unit to the interior, bundle both insulated refrigerant pipes, the drain hose, and outdoor unit to indoor unit / branch distribution unit communication / connection (power) cable together with wide vinyl tape.

1. Piping must be fully encased in insulation material: Overlap the field installation piping insulation material and the indoor unit piping insulation material.
2. Bind together the two pipes, using vinyl tape. Make sure there are no gaps during the binding.
3. Be sure the cutting line is placed upward.
4. Wrap the rear piping section with narrow vinyl tape.
5. Continue to wrap the indoor unit pipe as connected to the outdoor connection pipe.
6. Using a wider vinyl tape, bundle the piping and drain hose together.
  - Tape must be sufficient to cover the piping in order to fit into the rear piping housing area at the back of the indoor unit.

## Special Applications

If an additional drain hose is necessary, the end of drain outlet must be routed above the ground. Secure the drain hose appropriately.

### When the Outdoor Unit is Installed Below the Indoor Unit:

1. Use a conduit, piping set cover, or bundle the (separately) insulated refrigerant piping, the drain hose, and the communications / connection (power) cable together.
2. Make sure to include some slack in the wiring. Wiring must be installed in an upwards direction to prevent water from accessing into the control box.
3. Secure the conduit, piping set cover, or bundle along the outside wall using saddles or a similar type of piping support.
4. Seal any openings in the wall that are around the piping.

### When the Outdoor Unit is Installed Above the Indoor Unit:

1. Use a conduit, piping set cover, or bundle the (separately) insulated refrigerant piping and the communications / connection (power) cable together up to the outdoor unit service valves.
2. Make sure to include some slack in the wiring. Wiring must be installed in upwards direction to prevent water from traveling into the control box.
3. If necessary, secure the conduit, piping set cover, or bundle along the outside wall using saddles or a similar type of piping support.
4. Ensure the insulated drain hose from the indoor unit is installed away from the outdoor unit, and in a downwards direction. If necessary, secure along the outside wall using saddles or a similar type of support.
5. Seal any openings in the wall that are around the piping.

Figure 60: Bundling the Connection Components (From Outdoor Unit to Indoor Unit / Branch Distribution Unit [Multi F MAX with LGRED systems only]).

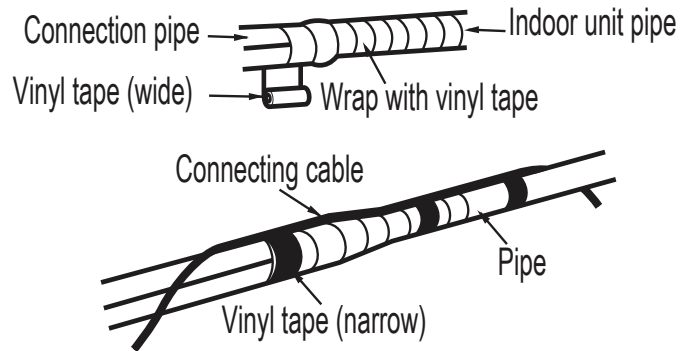
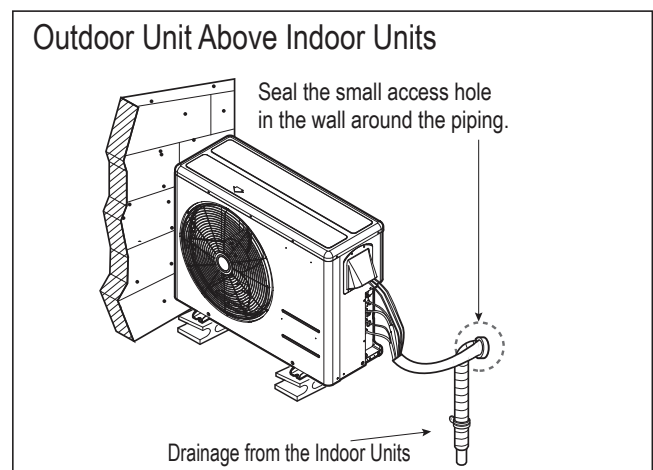
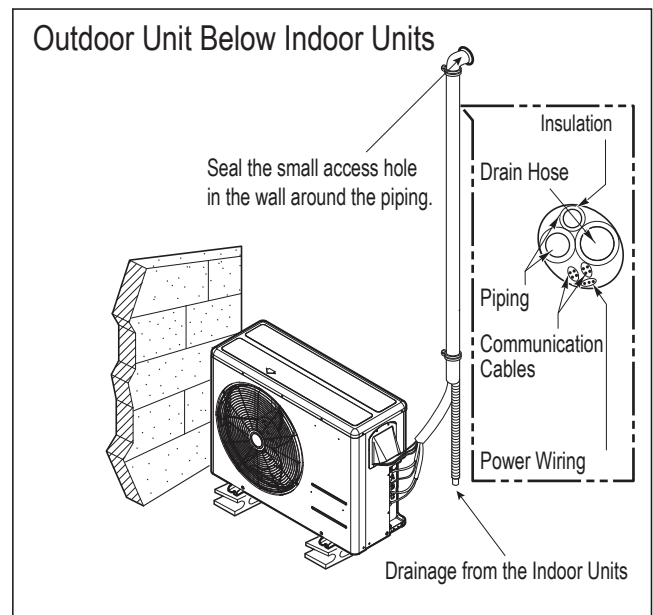

Figure 61: Special Applications.



---

---

## Condensate Drain Piping

Outdoor unit requires condensate drain piping. Condensate drain pipe must be constructed with materials approved by local code. See pages 20 to 22 for information in reference to outdoor unit placement and condensate drainage.

### Drain Leak Test

A leak test must be performed 24 hours after the drainage system has been installed.

### Note:

*For indoor unit condensate drain piping information, see the Multi F / Multi F MAX Indoor Unit Engineering Manual, or the installation manual specific to the indoor unit type.*

**Note:**

For information regarding insulation for underground or penetration situations, see the “General Refrigerant Piping System Information” section.

**General Piping System Insulation**

All refrigerant piping from the outdoor unit to the indoor units / branch distribution units (Multi F MAX with LGRED systems only) must be insulated correctly for safety and usage. Y-branch connections, refrigerant piping, field-provided isolation ball valves (if present), service valves, and elbows must be properly and completely insulated using closed cell pipe insulation (up to the indoor unit piping connections). To prevent heat loss / heat gain through the refrigerant piping, all refrigerant piping including liquid lines and vapor lines must be insulated separately. Insulation must be a minimum 1/2 inches thick, and thickness will need to be increased based on ambient conditions and local codes. Table on the next page lists minimum wall thickness requirements for Ethylene Propylene Diene Methylene (EPDM) insulation.

Inside the outdoor unit, maximum pipe temperature is 248°F and minimum pipe temperature is -40°F. For field insulation of refrigerant piping between outdoor units and indoor units, consider the following pipe temperature ranges for an operating heat pump system:

- Heating mode refrigerant temperature ranges: Liquid, 75-118°F; High Pressure Vapor, 95-220°F.
- Cooling mode refrigerant temperature ranges: Liquid, 75-118°F; Low Pressure Vapor, 40-90°F.

All insulation joints must be glued with no air gaps. Insulation material must fit snugly against the refrigeration pipe with no air space between it and the pipe. Insulation passing through pipe hangers, inside conduit, and/or sleeves must not be compressed. Protect insulation inside hangers and supports with a second layer. All pipe insulation exposed to the sun and outdoor elements must be properly protected with PVC, aluminum vapor barrier, or alternatively placed in a weather-resistant enclosure such as a pipe rack with a top cover; and meet local codes. LG-provided Y-branches are shipped from the factory with pre-formed peel-and-stick foam insulation jackets, with a 1.84 lb./ft.<sup>3</sup> density, 1/2 inch thickness, and meet UL94 MF-1 flammability.

The design engineer must perform calculations to determine if the factory-supplied insulation jackets are sufficient to meet local codes and avoid sweating. Add additional insulation if necessary. Check the fit of the insulation jacket after the Y-branch fitting and all run-out pipes are installed.

Figure 62: Typical Pipe Insulation, Power Wire and Communications Cable Arrangement

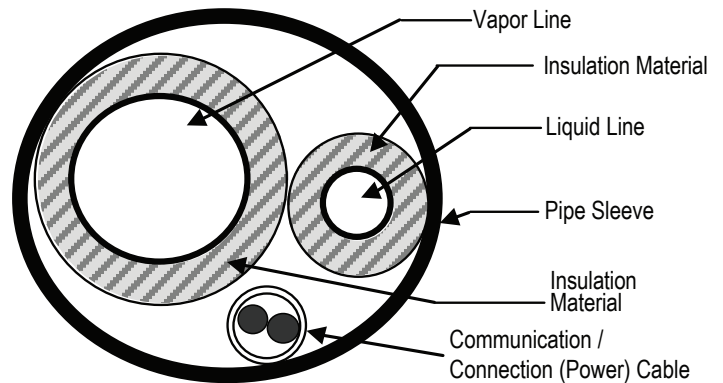

Figure 63: Typical Insulation Butt-Joint at Indoor Unit Casing.

Figure 64: Typical Refrigerant Flare Fitting Insulation Detail.

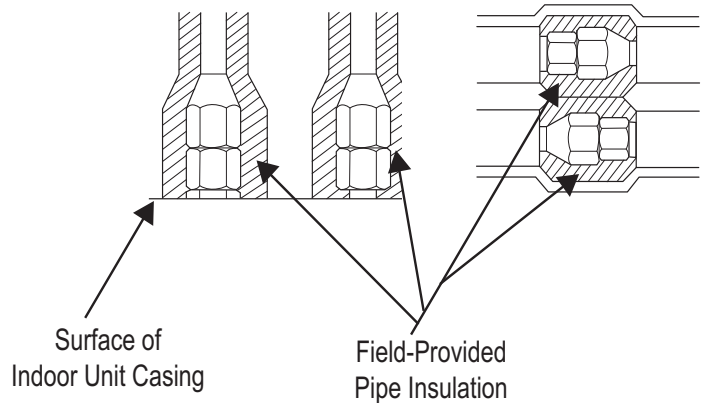
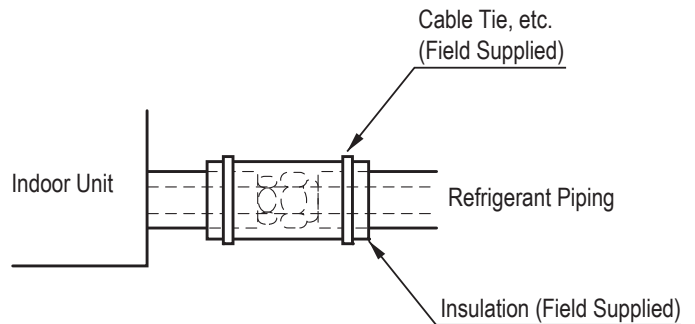

Figure 65: Insulating the Shut Off / Isolation Ball Valve (If Present).



## Minimum Refrigerant Pipe Ethylene Propylene Diene Methylene (EPDM) Insulation Wall Thickness Requirements

### Note:

- Do not insulate gas and liquid pipes together as this can result in pipe leakage and malfunction due to extreme temperature fluctuations.
- Always properly insulate the piping. Insufficient insulation will result in condensation, reduced heating/cooling performance, etc. Also, if the pipes aren't insulated properly, condensation could potentially cause damage to building finishes. Pay special attention to insulating the pipes installed in the ceiling plenum.
- Fully insulate the piping connections.
- Follow local codes and the designer's instructions when selecting ethylene propylene diene methylene (EPDM) insulation wall thickness.

Table 31: Minimum Refrigerant Pipe EPDM Insulation Wall Thickness Requirements.<sup>1</sup>

Classification		Air-conditioned location		Non-air conditioned location	
		1. Typical Conditioned Location	2. Special Conditioned Location	3. Typical Unconditioned Location	4. Special Unconditioned Location
Liquid pipe	ø1/4 inch	>1/2 inch	>1/2 inch	>1/2 inch	>1/2 inch
	ø3/8 inch	>1/2 inch	>1/2 inch	>1/2 inch	>1/2 inch
	≥ø1/2 inch	>1/2 inch	>1/2 inch	>1/2 inch	>1/2 inch
Vapor pipe	ø3/8 inch	>1/2 inch	>3/4 inch	>3/4 inch	>1 inch
	ø1/2 inch				
	ø5/8 inch				
	ø3/4 inch				
	ø7/8 inch				
	ø1 inch	>3/4 inch	>1 inch	>1 inch	
	ø1-1/8 inches				
	ø1-1/4 inches				
	ø1-3/8 inches				
	ø1-1/2 inches				
ø1-3/4 inches					

<sup>1</sup>The thickness of the above insulation material is based on heat conductivity of 0.61 Btu/in/h/ft<sup>2</sup>/°F.

### 1. Typical Conditioned Location

A building plenum or space that contains conditioned air that does not exceed 80°F DB.

### 2. Special Conditioned Location

1. When the location is air conditioned, but there is severe temperature/humidity difference due to high ceilings.
  - Church, auditorium, theater, lobby, etc.
2. When the location is air conditioned, but internal temperature/humidity are high.
  - Bathroom, swimming pool, locker room, etc.

### 3. Typical Unconditioned Location

An unconditioned space inside a building.

### 4. Special Unconditioned Location: If conditions 1 and 2 below are present.

1. An unconditioned space or plenum of a building.
2. An area where there is an elevated humidity level.

### 5. Additional Insulation for Indoor Units Will be Required in Humid Environments.

The air conditioner factory insulation has been tested according to "ISO Conditions with Mist," and it satisfies the requirements. If the system has been operating for a long time in a high humidity environment (dew point temperature: more than 73°F), condensate is likely to form. If this happens, install 3/8 inch thick EPDM insulation that is plenum-rated with a heat-resistance factor of more than 248°F.

**Note:**

- Do not insulate gas and liquid pipes together as this can result in pipe leakage and malfunction due to extreme temperature fluctuations.
- Be sure to fully insulate the piping connections.

**Installing the Insulation**

1. Insulation material must be longer than the refrigerant piping. Each vapor and liquid piping must be insulated separately.
2. Place the closed-cell ethylene propylene diene methylene (EPDM) insulation material carefully around each refrigerant pipe so as not to damage it. Be sure the insulation material cutting line is placed upward.
3. Apply adhesive to both cut surfaces of the insulation and press together. Allow adhesive to dry so that the bond is secure and does not come apart.

**Insulating Piping Joints**

1. Push the EPDM insulation from the straight piping surrounding the joint (elbow, outdoor unit to indoor unit piping connection point, etc.) as close together as possible.
2. Cut a piece of insulation to fit the joint, overlapping the insulation on the surrounding piping by at least one (1) inch.
3. Apply adhesive to bond all the ends.
4. Secure by completely wrapping narrow vinyl tape around the insulation / joint so that there are no gaps.
5. Tape must be sufficient to cover the piping so it can fit into the rear piping housing area at the back of the indoor unit or branch distribution unit (Multi F MAX with LGRED systems only).

**Y-Branch Kit Insulation**

Each Y-branch kit comes with clam-shell type peel-and-stick insulation jackets molded to fit the Y-branch fittings—one for the liquid line, one for the vapor line.

- Check the fit of the Y-branch clam-shell insulation jacket after the Y-branch is installed.
- Mark all the pipes at the points where the insulation jacket ends.
- Remove the jacket.
- Install field-provided insulation on the run-out and main pipes first.
- Peel the adhesive glue protector slip from the insulation jacket, and install the clam-shell jacket over the fitting.

Figure 68: Y-branch Insulation Detail.

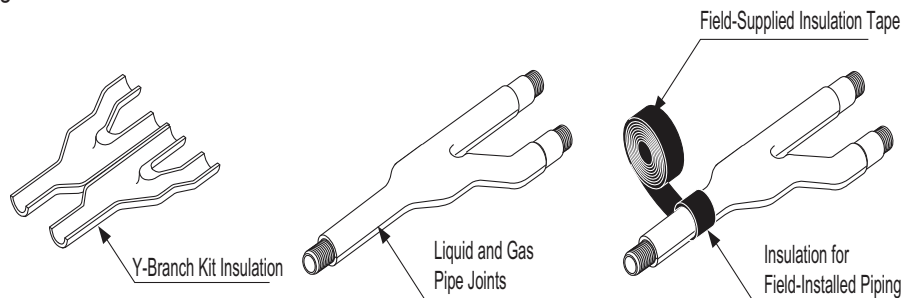

**Note:**

**Additional Insulation for Y-Branches Will be Required in Humid Environments.**

If the system has been operating for a long time in a high humidity environment (dew point temperature: more than 73°F), condensate is likely to form. If this happens, install 3/8 inch thick ethylene propylene diene methylene (EPDM) insulation that is plenum-rated with a heat-resistance factor that follows applicable local, state, and federal codes.

Figure 66: Correct Cutting Line Placement.

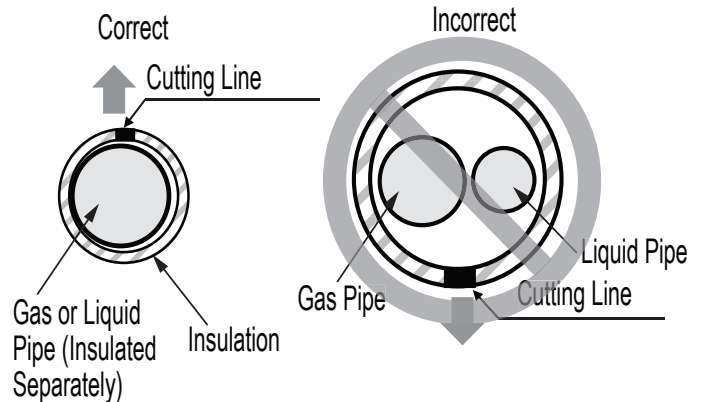
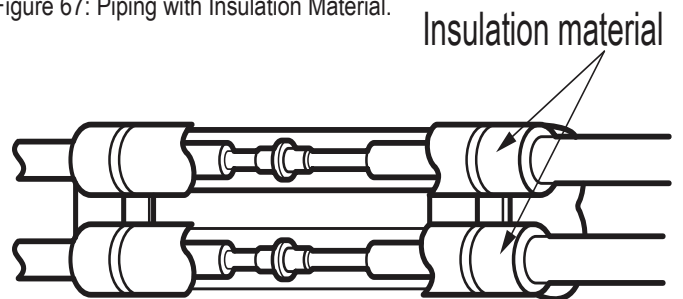

Figure 67: Piping with Insulation Material.





# ELECTRICAL

## General Information

### ⚠ WARNING

- All power (line voltage) wiring and communication cable installation must be performed by trained service providers working in accordance with all local, state, and National Electrical Code (NEC) / UL / ETL federal regulations related to electrical equipment and wiring, and following the manufacturer product diagrams, requirements, and instructions in this manual. Electric shock can cause physical injury or death.
- Be sure that main power to the unit is completely off before proceeding. Follow all safety and warning information outlined at the beginning of this manual. Failure to do so will cause electric shock and bodily injury.
- Install a main shutoff switch or circuit breaker that interrupts all power sources simultaneously (circuit breaker must be resistant to electromagnetic currents). Be sure that the circuit breaker or some other emergency power cutoff device is in place before any power wiring is done to the system. Failure to do so will cause bodily injury or death.
- ⚡ Never touch any power lines or live cables before all power is cutoff to the system. To do so will cause bodily injury or death.
- Power wiring and communication cable sizes must comply with all applicable federal, state, and local codes. Undersized wiring will lead to unacceptable voltage at the unit and will cause a fire, which will cause bodily injury or death.
- Properly ground the outdoor unit, indoor units, and branch distribution units. Ground wiring must always be installed by a trained technician. Ground wiring is required to prevent accidental electrical shock during current leakage, which will cause bodily injury or death.
- Verify that the circuit breaker is set to OFF before installing the wiring system. Electric shock can cause physical injury or death.
- Install appropriately sized breakers / fuses / overcurrent protection switches and wiring in accordance with local, state, and NEC regulations related to electrical equipment and wiring, and following the instructions in this manual. Generated overcurrent will include some amount of direct current. Using an oversized breaker or fuse will result in electric shock, physical injury or death.
- ⚡ Do not connect ground wire to refrigerant, gas, sewage, or water piping; to lightning rods; to telephone ground wiring; or to the building plumbing system. Failure to properly provide a NEC-approved earth ground can result in electric shock, fire, physical injury or death.

### Note:

- Consider ambient conditions (temperature, direct sunlight, inclement weather, etc.) when selecting, installing, and connecting the power wiring.
- Properly ground the outdoor unit, indoor units, and branch distribution units. Ground wiring must always be installed by a trained technician. Improperly grounded wire can cause communication problems from electrical noise, and motor current leakage.
- Install appropriately sized breakers / fuses / overcurrent protection switches and wiring in accordance with local, state, and NEC regulations related to electrical equipment and wiring, and following the instructions in this manual. Generated overcurrent will include some amount of direct current. Using an oversized breaker or fuse will result in equipment malfunction and property damage.
- ⚡ Do not connect ground wire to refrigerant, gas, or water piping; to lightning rods; to telephone ground wiring; or to the building plumbing system. Failure to properly provide a NEC-approved earth ground can result in property damage and equipment malfunction.
- ⚡ Do not operate the air conditioning system until the refrigerant piping installation is complete. Operating the system before refrigerant piping is finalized will damage the compressor.

## Location / Accessing the Power Wiring and Communications Cable Connections

1. Detach the outdoor unit panel by loosening the screws.
2. Remove the control cover (if applicable) by loosening the screws.
3. When all connections are complete, re-attach the cover control to its original position using the screws, then re-attach the outdoor unit panel.

Figure 69: Power Wiring and Communication / Connection (Power) Cable Paths (LMU180-240-300HHV Example).

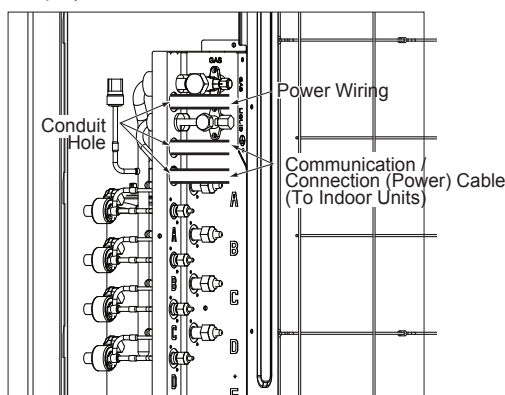
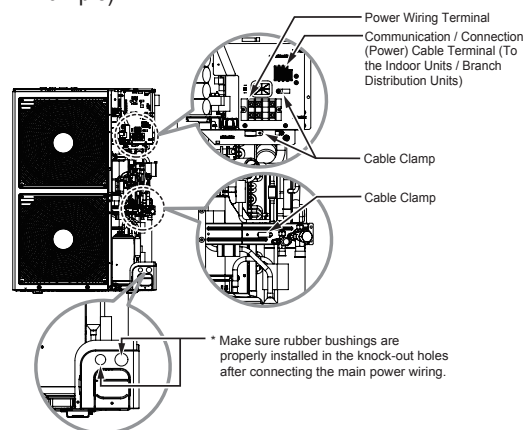

Figure 70: Location of the Power Wiring and Communication Cable Terminals (LMU360-420HHV Example).





### Power Wiring / Communication Cable Connections

Best practice dictates using solderless ring or fork terminals at all power wiring and communication cable terminations. Use copper bearing ring or fork terminals; do not use galvanized or nickel plate over steel. Use appropriate crimping tool to attach the ring or fork terminals at all power wiring and control cable terminations.

#### To Install a Ring or Fork Terminal:

1. Trim the wiring with wire cutters or pliers, then strip the insulation to expose the strand wiring to about 3/8 inches.
2. Using a ring terminal fastener or pliers, securely clamp a ring terminal to each stripped wire end.

#### To Connect the Wiring to the Terminals:

1. Remove the JIS terminal screws from the (outdoor unit, branch distribution unit, or indoor unit) terminal plate with a JIS screwdriver. (See information about LG terminal connections on the next page.)
2. Position the ring terminal around the terminal, place the terminal screw in the ring, and tighten to the terminal plate using a JIS screwdriver.
  - Firmly attach the wire; secure in a way to prevent external forces from being imparted to the terminal block.
  - Use an appropriately sized JIS screwdriver for tightening the terminals.
  - Do not over tighten the connections; over tightening will damage the terminals.

If ring terminals or fork terminals are not available, then:

- Do not terminate different gauge wires to the power terminal block. (Slack in the wiring will generate heat.)
- When terminating wires of the same thickness, follow the instructions demonstrated in the figures below.

Figure 74: Proper and Improper Power Wiring Connections.

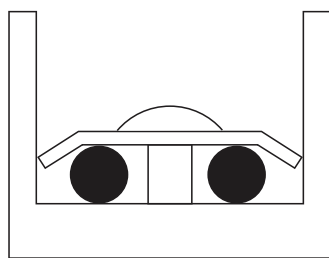

Terminate multiple power wires of the same gauge to both sides.

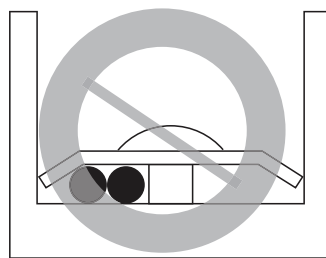

Do not terminate two wires on one side.

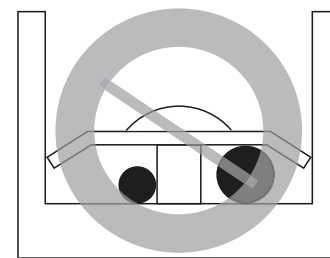

Do not terminate different gauge wires to a terminal block.

### WARNING

If power wires are not properly terminated and firmly attached, there is risk of fire, electric shock, and physical injury or death.

#### Note:

- Never apply line voltage power to the communications cable terminal block. If contact is made, the PCBs will be damaged.
- Always include some allowance in the wiring length when terminating. Firmly attach the wiring or cable, but provide some slack to facilitate removing the electrical panels while servicing, and to prevent external forces from damaging the terminal block.

Figure 71: Close up of a Typical Ring Terminal.

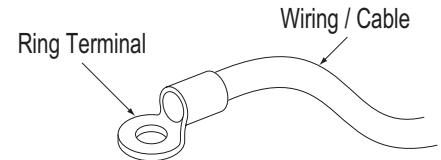

Figure 72: Adding a Ring Terminal to the Wiring.

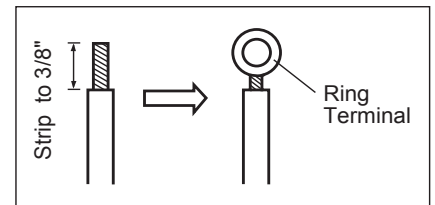
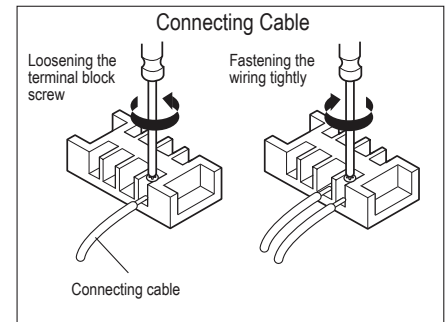

Figure 73: Tightening the Ring Terminal to the Terminal Plate.



:Copper Wire

# ELECTRICAL

## Connections and Specifications

### LG Terminal Connections

LG uses a “JIS” type of screw for all terminals; use a JIS screwdriver to tighten and loosen these screws and avoid damaging the terminal. ⚠ Do not over tighten the connections — over tightening will damage the terminals — but firmly and securely attach the wiring in a way to prevent external forces from being imparted to the terminal block.

#### Note:

- The terminals labeled “GND” are NOT ground terminals. The terminals labeled  ARE ground terminals.
- Polarity matters. Always connect “A” to “A” and “B” to “B.”
- Always create a wiring diagram that contains the exact sequence in which all the indoor units and branch distribution units (Multi F MAX with LGRED systems only) are wired in relation to the outdoor unit.
- ⚠ Do not include splices or wire nuts in the communication cable.

Figure 75: JIS Screws.



JIS DIMPLES

### Power Supply / Power Wiring Specifications

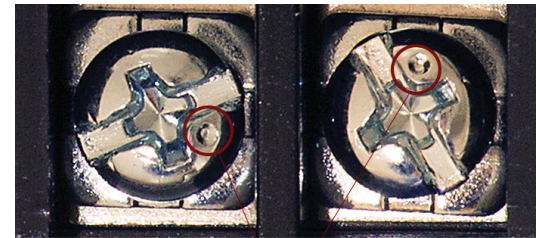
- Multi F and Multi F MAX with LGRED systems operate at 1Ø, 208-230V, 60Hz, and power is wired to the outdoor unit only. The outdoor unit will supply power to the indoor units and the branch distribution units (Multi F MAX with LGRED systems only) through the communication / connection (power) cable.
- Power supply to the outdoor unit must be selected based on NEC and local codes. Maximum allowable voltage fluctuation  $\pm 10\%$  or nameplate rated value.
- Power wiring to the outdoor unit(s) must be solid or stranded, and must comply with all local and national electrical codes.
- Properly ground the outdoor unit and indoor unit per NEC and local codes.
- Ground wire must be longer than the common power / communication wires.
- Connect the wiring firmly so the wires cannot be easily pulled out.
- Refer to the inside of the chassis cover or control cover for circuit and terminal block diagrams.
- Always match color codes of each wire and follow wiring diagram.
- ⚠ Do not install power wiring to the outdoor unit and the communication / connection (power) cable to the indoor unit in the same conduit. Use separate conduits.

Figure 77: Multi F / Multi F MAX with LGRED Outdoor Unit Power Wiring.

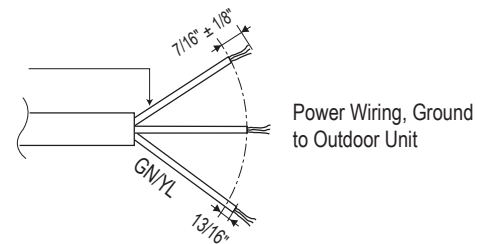
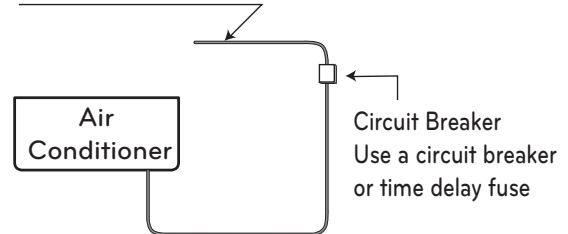

Table 32: Circuit Breaker / Fuse Size.

Outdoor Unit Model	Power Source	Maximum Overcurrent Protection	Recommended Fuse Amps
LMU180HHV	1Ø, 208-230V	30A	25A
LMU240HHV	1Ø, 208-230V	30A	25A
LMU300HHV	1Ø, 208-230V	30A	25A
LMU360HHV	1Ø, 208-230V	45A	-
LMU420HHV	1Ø, 208-230V	45A	-

Figure 76: Circuit Breaker Main Power Source



### ⚠ WARNING

- Always have a trained service provider properly ground the outdoor unit. If the outdoor unit is not properly grounded, there is a risk of electric shock, physical injury, or death.
- Provide a circuit breaker between the power source and the outdoor unit. Failure to do so will cause bodily injury or death.

### Communication / Connection (Power) Cable Specifications

- Multi F with LGRED Systems:

- Communication / connection (power) cable from the outdoor unit to the indoor unit for lengths up to 130 feet must use a minimum of 14 AWG, four (4) conductor, stranded, shielded or unshielded (if shielded, it must be grounded to the chassis of the outdoor unit only), and must comply with applicable local and national codes.
- When the communication / connection (power) wires between the indoor unit and outdoor unit is GREATER THAN 130 feet, use:
  - A two (2) conductor wire for power (for each indoor unit).
  - A two (2) conductor wire for communication / ground (for each indoor unit).
  - Separate the power AT LEAST two (2) inches away from the communication / ground wire (for each indoor unit).
  - All wiring is still minimum 14 gauge, stranded, shielded, or unshielded as cited above (for each indoor unit).

- Multi F MAX with LGRED Systems:

- All communication / connection (power) cable from the outdoor unit to the branch distribution unit(s) must be a minimum of 14 AWG, four (4) conductor, stranded, shielded or unshielded (if shielded, it must be grounded to the chassis of the outdoor unit only), and must comply with applicable local and national codes.
- Communication / connection (power) cable from the branch distribution unit(s) to the indoor units for lengths up to 130 feet must use a minimum of 14 AWG, four (4) conductor, stranded, shielded or unshielded (if shielded, it must be grounded to the chassis of the outdoor unit only), and must comply with applicable local and national codes.
- When the communication / connection (power) wires between the branch distribution unit and indoor unit is GREATER THAN 130 feet, use:
  - A two (2) conductor wire for power (for each indoor unit).
  - A two (2) conductor wire for communication / ground (for each indoor unit).
  - Separate the power AT LEAST two (2) inches away from the communication / ground wire (for each indoor unit).
  - All wiring is still minimum 14 gauge, stranded, shielded, or unshielded as cited above (for each indoor unit).

- Insulation material as required by local code.
- Rated for continuous exposure of temperatures up to 140°F.
- Firmly attach the cable; provide slack but secure in a way to prevent external forces from being imparted on the terminal block.
- Wiring must be completed without splices.

### Note:

- Use a conduit for the communications / connection (power) cable from the outdoor unit to the indoor units and branch distribution unit(s). Electrical interference may cause product malfunction.
- Never ground the shield of the communications cable to the indoor unit frame or other grounded entities of the building. Ground the communications cable shield only at the outdoor unit. Improperly grounding this cable can cause communications errors.
- The communications / connection (power) cable from the outdoor unit to the indoor units / branch distribution unit(s) must be separated and isolated from power wiring to the outdoor unit, computers, radio and television broadcasting facilities, as well as medical imaging equipment. Electrical interference may cause product malfunction.

Figure 78: Typical Multi F / Multi F MAX with LGRED Outdoor and Indoor / Branch Distribution Unit Wiring and Communications Cable Diagram For Wiring Lengths Up to 130 Feet.

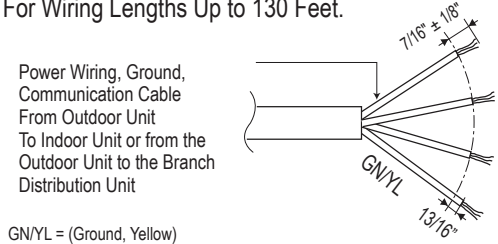

GN/YL = (Ground, Yellow)

Figure 79: Multi F with LGRED Outdoor Unit to Indoor Unit, and Multi F MAX with LGRED Branch Distribution Unit to Indoor Unit Wiring Diagram for Wiring Lengths GREATER THAN 130 Feet.

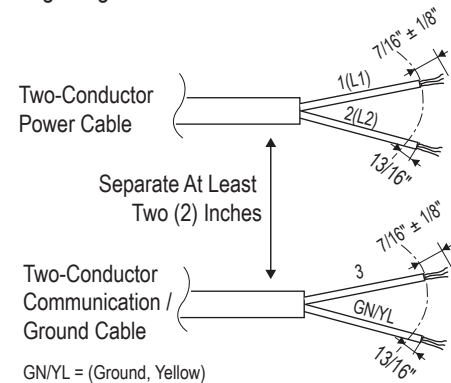

GN/YL = (Ground, Yellow)

# ELECTRICAL

## Connections and Specifications

Figure 80: Typical Multi F with LGRED System General Power / Communications System Schematic When Wiring is Less Than 130 Feet.

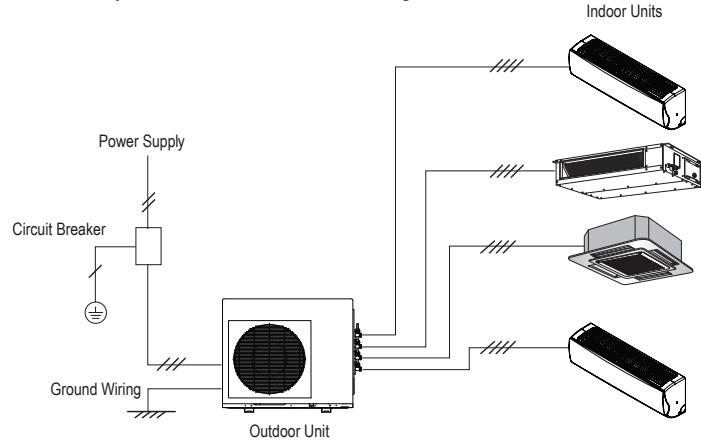

Figure 81: Typical Multi F MAX with LGRED System General Power / Communications System Schematic When Wiring is Less Than 130 Feet.

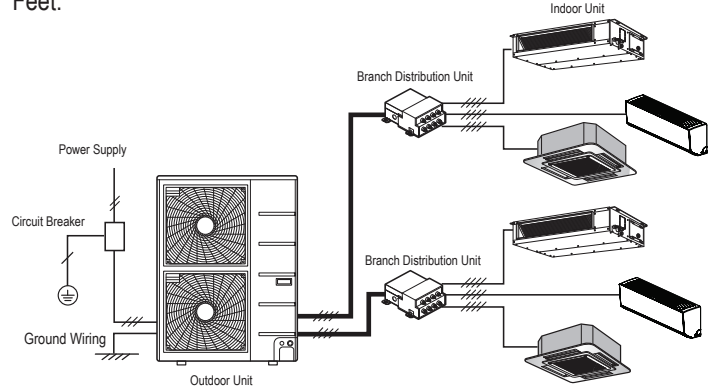

Figure 82: Schematic of a Multi F with LGRED System When the Wiring is GREATER THAN 130 Feet.

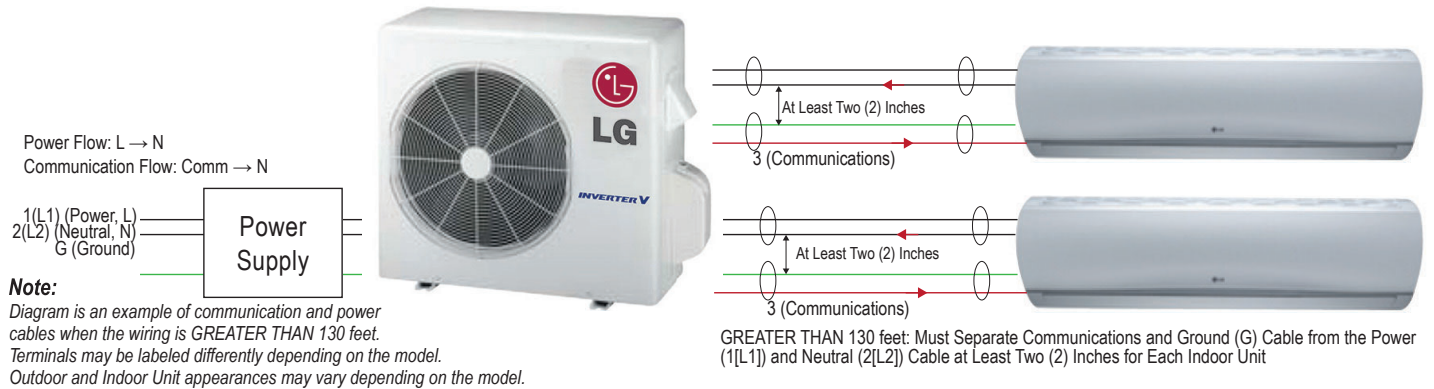

Figure 83: Schematic of a Multi F MAX with LGRED System When the Wiring is GREATER THAN 130 Feet.

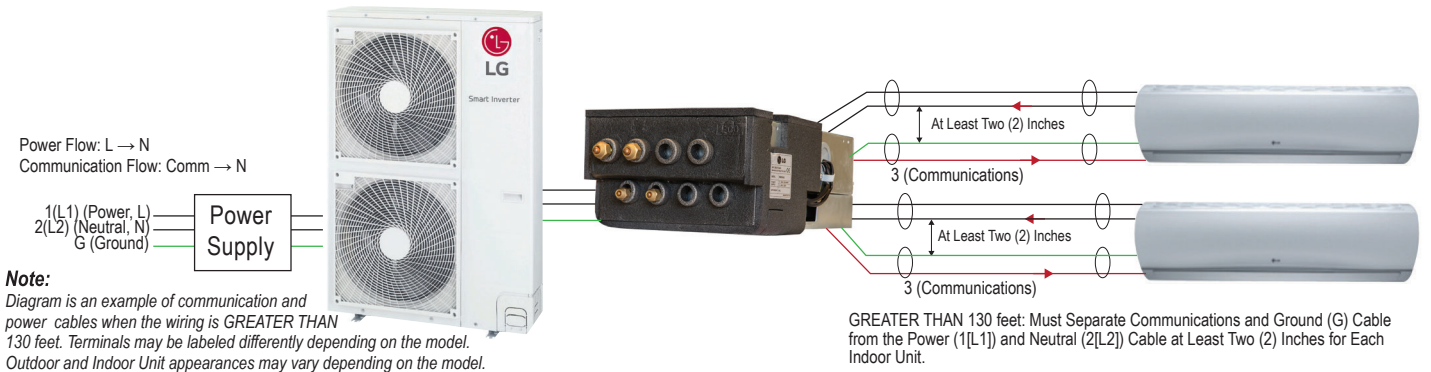
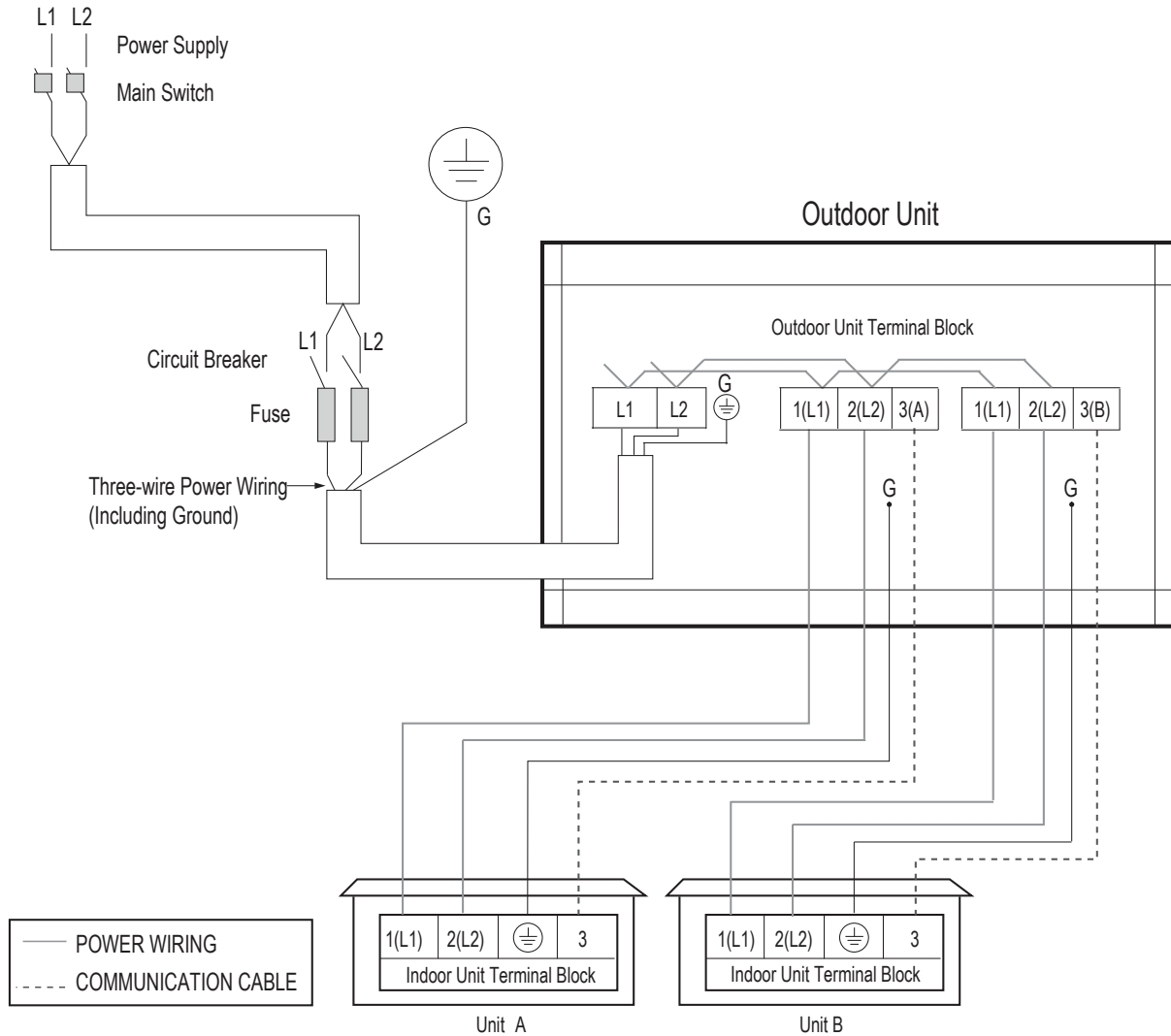

Figure 84: Multi F with LGRED LMU180HHV System Power Wiring and Communications Cable Connections.



### ⚠ WARNING

- All field-supplied wiring, components, sizes, and materials must comply with all applicable national, state, and local codes and requirements. Improper wiring will result in fire, electric shock, physical injury or death.
- Ground wiring is required to prevent accidental electrical shock during current leakage, communication problems from electrical noise, and motor current leakage. ⚡ Do not connect the ground line to the pipes. There is a risk of fire, electric shock, explosion, physical injury or death.
- Install a main shutoff switch or circuit breaker that interrupts all power sources simultaneously. There is a risk of fire, electric shock, explosion, physical injury or death.

### Note:

- All field-supplied wiring, components, sizes, and materials must comply with all applicable national, state, and local codes and requirements. Failure to install proper electrical components can result in property damage and equipment malfunction.
- Ground wiring is required to prevent communication problems from electrical noise, and motor current leakage. Failure to provide proper ground wiring can result in property damage and equipment malfunction.
- Install a main shutoff switch or circuit breaker that interrupts all power sources simultaneously. Failure to install proper electric components can result in property damage and equipment malfunction.
- Maintain polarity throughout the communication network. The system will malfunction if not properly wired.



# ELECTRICAL

## Installation

Figure 85: Multi F with LGRED LMU240HHV System Power Wiring and Communications Cable Connections.

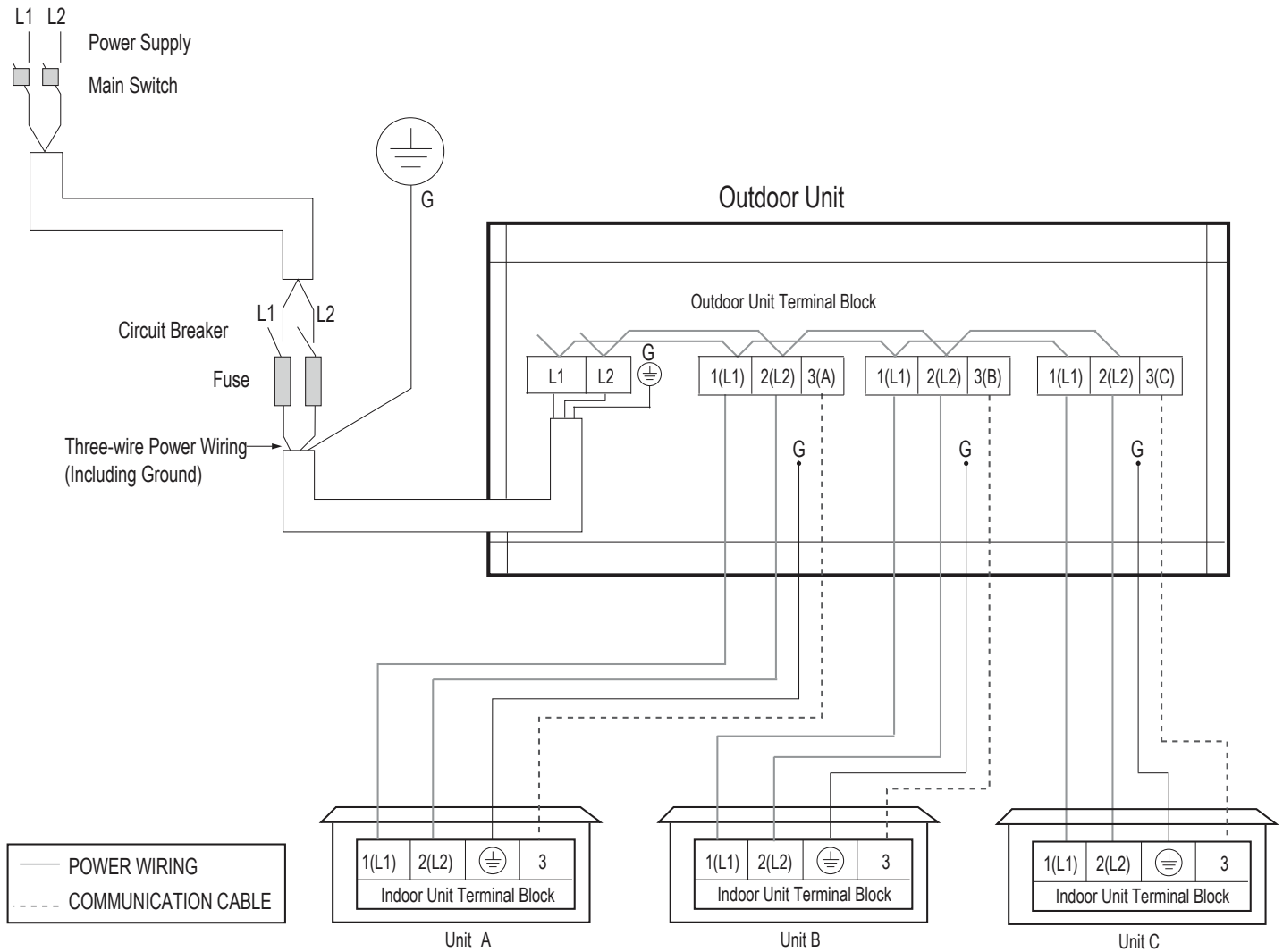

### ⚠ WARNING

- All field-supplied wiring, components, sizes, and materials must comply with all applicable national, state, and local codes and requirements. Improper wiring will result in fire, electric shock, physical injury or death.
- Ground wiring is required to prevent accidental electrical shock during current leakage, communication problems from electrical noise, and motor current leakage. ⚡ Do not connect the ground line to the pipes. There is a risk of fire, electric shock, explosion, physical injury or death.
- Install a main shutoff switch or circuit breaker that interrupts all power sources simultaneously. There is a risk of fire, electric shock, explosion, physical injury or death.

### Note:

- All field-supplied wiring, components, sizes, and materials must comply with all applicable national, state, and local codes and requirements. Failure to install proper electrical components can result in property damage and equipment malfunction.
- Ground wiring is required to prevent communication problems from electrical noise, and motor current leakage. Failure to provide proper ground wiring can result in property damage and equipment malfunction.
- Install a main shutoff switch or circuit breaker that interrupts all power sources simultaneously. Failure to install proper electric components can result in property damage and equipment malfunction.
- Maintain polarity throughout the communication network. The system will malfunction if not properly wired.



Figure 86: Multi F with LGRED LMU300HHV System Power Wiring and Communications Cable Connections.

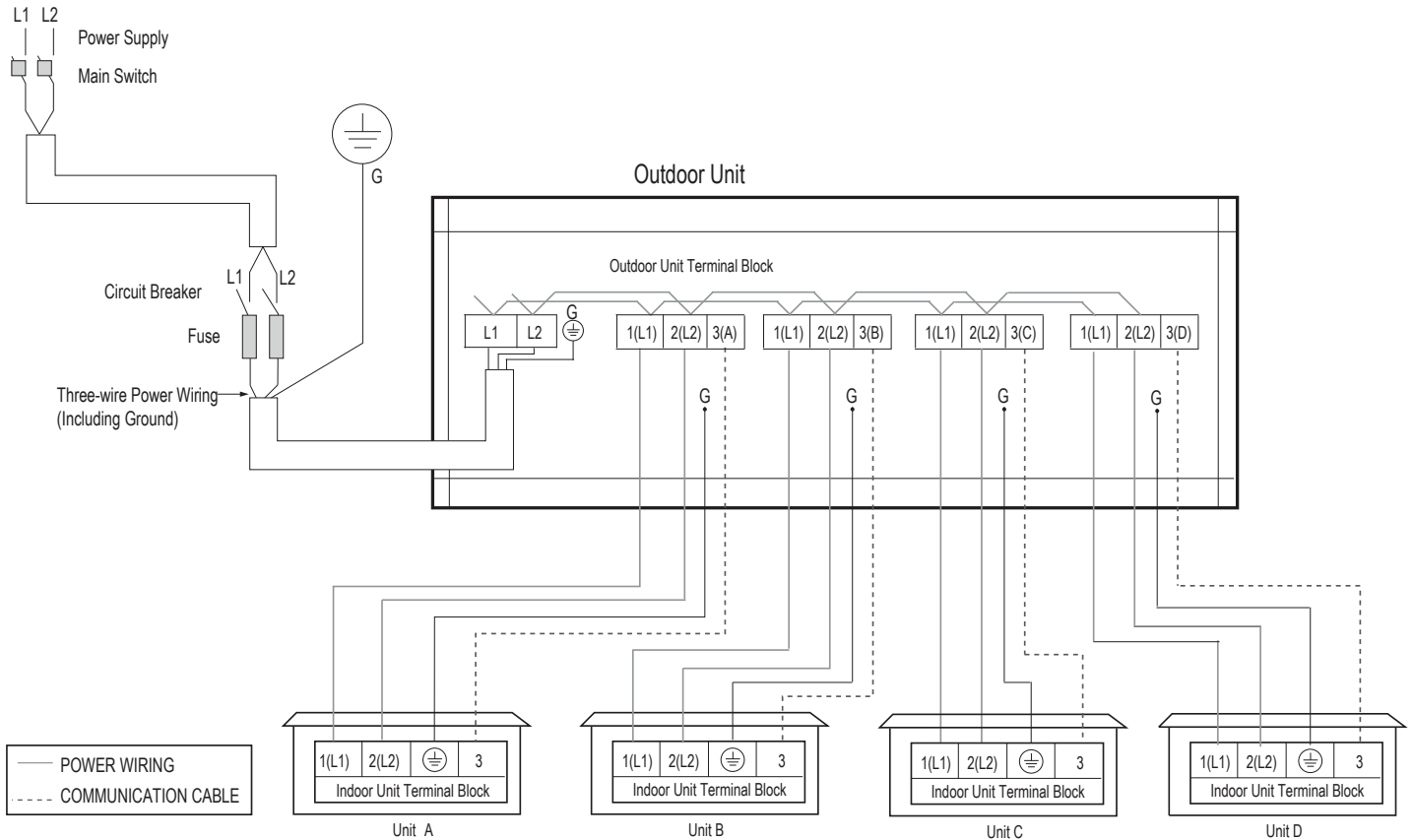

### ⚠ WARNING

- All field-supplied wiring, components, sizes, and materials must comply with all applicable national, state, and local codes and requirements. Improper wiring will result in fire, electric shock, physical injury or death.
- Ground wiring is required to prevent accidental electrical shock during current leakage, communication problems from electrical noise, and motor current leakage. ⚡ Do not connect the ground line to the pipes. There is a risk of fire, electric shock, explosion, physical injury or death.
- Install a main shutoff switch or circuit breaker that interrupts all power sources simultaneously. There is a risk of fire, electric shock, explosion, physical injury or death.

### Note:

- All field-supplied wiring, components, sizes, and materials must comply with all applicable national, state, and local codes and requirements. Failure to install proper electrical components can result in property damage and equipment malfunction.
- Ground wiring is required to prevent communication problems from electrical noise, and motor current leakage. Failure to provide proper ground wiring can result in property damage and equipment malfunction.
- Install a main shutoff switch or circuit breaker that interrupts all power sources simultaneously. Failure to install proper electric components can result in property damage and equipment malfunction.
- Maintain polarity throughout the communication network. The system will malfunction if not properly wired.

# ELECTRICAL

## Installation

Figure 87: Multi F MAX with LGRED LMU360HHV and LMU420HHV System Power Wiring and Communications Cable Connections.

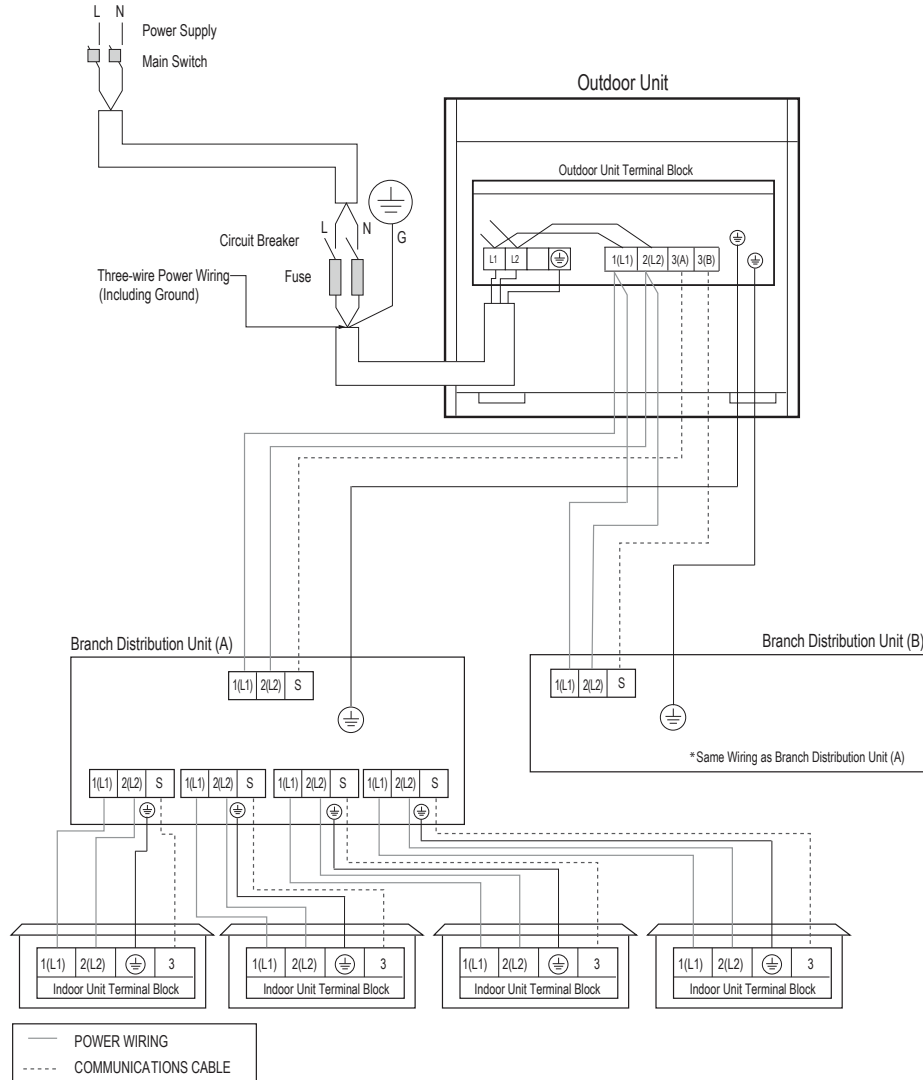

### ⚠ WARNING

- All field-supplied wiring, components, sizes, and materials must comply with all applicable national, state, and local codes and requirements. Improper wiring will result in fire, electric shock, physical injury or death.
- Ground wiring is required to prevent accidental electrical shock during current leakage, communication problems from electrical noise, and motor current leakage. ⚡ Do not connect the ground line to the pipes. There is a risk of fire, electric shock, explosion, physical injury or death.
- Install a main shutoff switch or circuit breaker that interrupts all power sources simultaneously. There is a risk of fire, electric shock, explosion, physical injury or death.

### Note:

- All field-supplied wiring, components, sizes, and materials must comply with all applicable national, state, and local codes and requirements. Failure to install proper electrical components can result in property damage and equipment malfunction.
- Ground wiring is required to prevent communication problems from electrical noise, and motor current leakage. Failure to provide proper ground wiring can result in property damage and equipment malfunction.
- Install a main shutoff switch or circuit breaker that interrupts all power sources simultaneously. Failure to install proper electric components can result in property damage and equipment malfunction.
- Maintain polarity throughout the communication network. The system will malfunction if not properly wired.

### Connecting the Communications / Connection (Power) Cables

1. Detach the outdoor unit panels by loosening the screws.
2. Remove the control cover (if applicable) by loosening the screws.
3. Remove the conduit knock outs or access holes.
4. Pull the power wiring, and the communications / connection (power) cable into the outdoor unit (through the conduits, if applicable). Ensure there is enough length to connect to the terminals on the outdoor unit. Secure any conduits with field-supplied lock nuts.
5. Connect the power wiring, and the communications / connection (power) cable to the correct terminals on the outdoor unit.
6. Connect communications / connection (power) cable to the correct control board terminals on the indoor unit (or branch distribution unit[s] if Multi F MAX with LGRED system).
7. Follow the wiring diagrams on the outdoor unit and indoor units (or branch distribution unit[s]) control covers. Ensure that the terminal board numbers and wiring color on the outdoor unit matches the terminal number and wiring color on the indoor unit or branch distribution unit(s).
8. Provide strain relief and help protect the connections by (separately) securing the wiring / cable to the outdoor unit with the factory-supplied clamps (up to 35 lbs.). Clamps are included near the terminal block. Zip ties can also be used to hold all cables in place.
9. For more installation information for specific indoor units, refer to the separate indoor unit installation manuals on [www.lghvac.com](http://www.lghvac.com).
10. When all connections are complete, reattach the control cover to its original position using the screws, then reinstall the outdoor unit panel.
11. After installation is complete, seal any gaps around the wiring in the panel access holes or the conduits.

### ⚠ WARNING

- Always have a trained technician properly ground the outdoor unit. If the outdoor unit is not properly grounded, there is a risk of electric shock, physical injury, or death.
- Failure to properly install wiring can result in electric shock, fire, physical injury or death.
- Failure to properly provide a NEC-approved earth ground can result in electric shock, fire, physical injury or death.
- Comply with local and national codes while running the wire from the indoor unit (and branch distribution units if Multi F MAX with LGRED system) to the outdoor unit (size of wire and wiring method, etc). Incorrectly sized wiring will cause the terminal to overheat, generate a fire, and risk physical injury or death.
- All wiring / cable must be firmly connected to its terminals. Loose wiring will cause the terminal to overheat, generate a fire, and risk physical injury or death.
- ⚡ Do not allow the wiring / cable to touch refrigerant tubing, the compressor, or any moving parts. It can result in electric shock, fire, physical injury or death.
- Replace all control box and panel covers. If cover panels are not installed securely, dust, water and animals may enter the outdoor unit, causing fire, electric shock, and physical injury or death.

### Note:

- Ensure the communications / connection (power) cable from the outdoor units to the indoor / branch distribution units, and the power wiring to the outdoor unit are separate; otherwise, the outdoor unit operation will be affected by electrical noise and will malfunction or fail.
- The communications / connection (power) cable from the outdoor unit to the indoor / branch distribution units must be separated and isolated from power wiring to the outdoor unit, computers, elevators, radio and television broadcasting facilities, as well as medical imaging equipment; otherwise, the outdoor unit operation will be affected by electrical noise and will malfunction or fail.
- All wiring / cable must be firmly connected to its terminals. Loose wiring will result in unit malfunction.

Figure 88: Multi F with LGRED Outdoor Unit Wiring Connections (LMU300HHV Example).

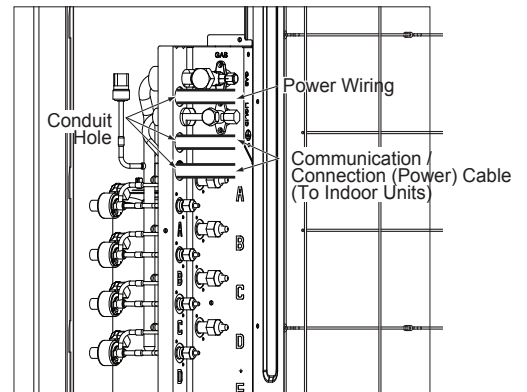

Figure 89: Multi F MAX with LGRED Outdoor Unit Wiring Connections Close Up View (LMU300HHV Example).

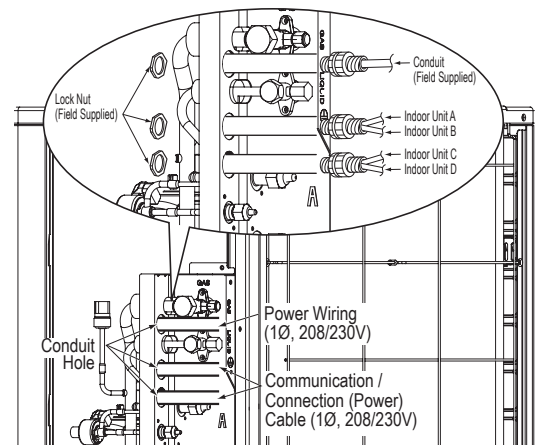
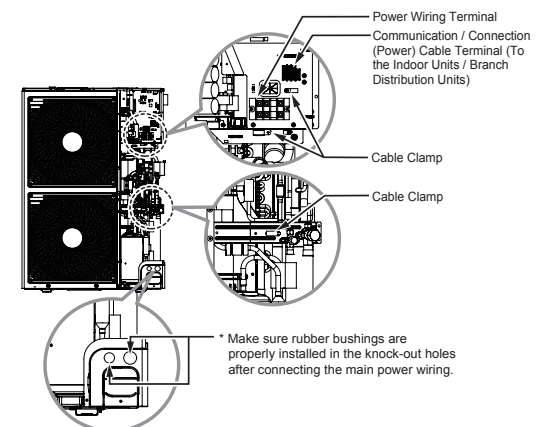

Figure 90: Multi F MAX with LGRED Outdoor Unit Wiring Connections (LMU360HHV Example).



# ELECTRICAL

## Installation

Figure 91: Detailed Diagrams of Outdoor Unit PCB Terminal Connections.

LMU180HHV (18kBtu/h)

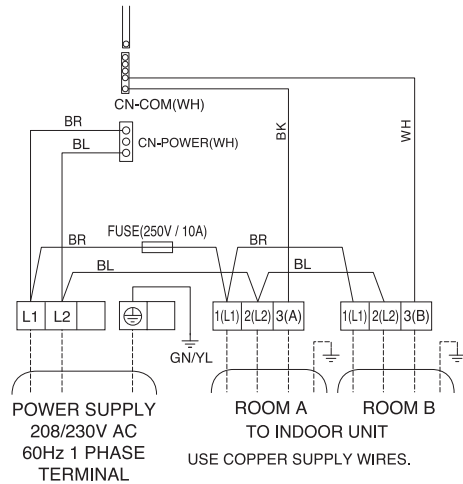

LMU240HHV (24kBtu/h)

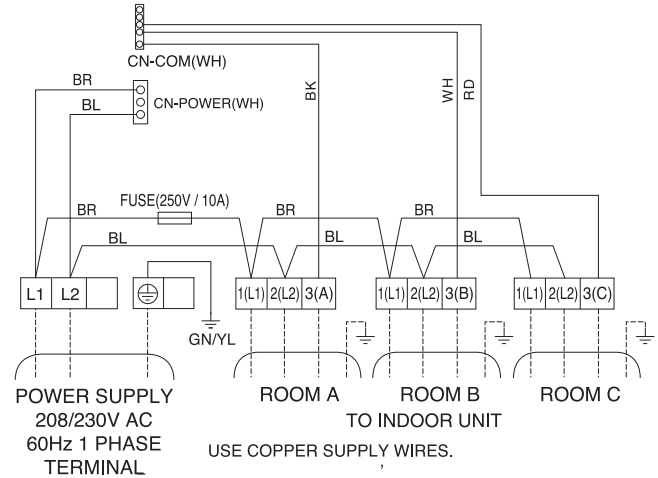

LMU300HHV (30kBtu/h)

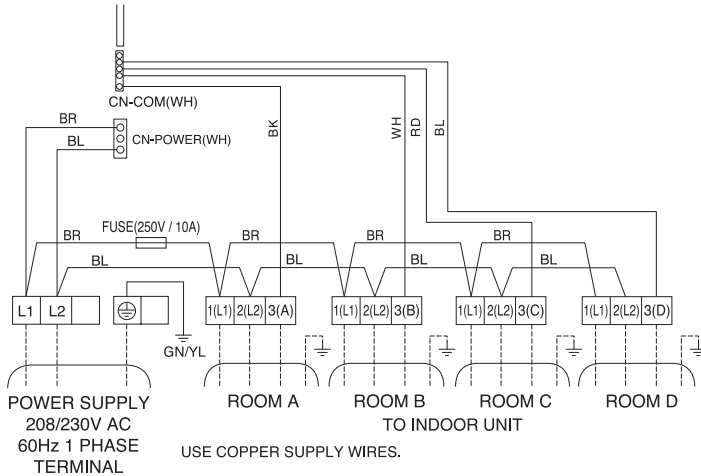

LMU360HHV (36kBtu/h) and LMU420HHV (42kBtu/h)

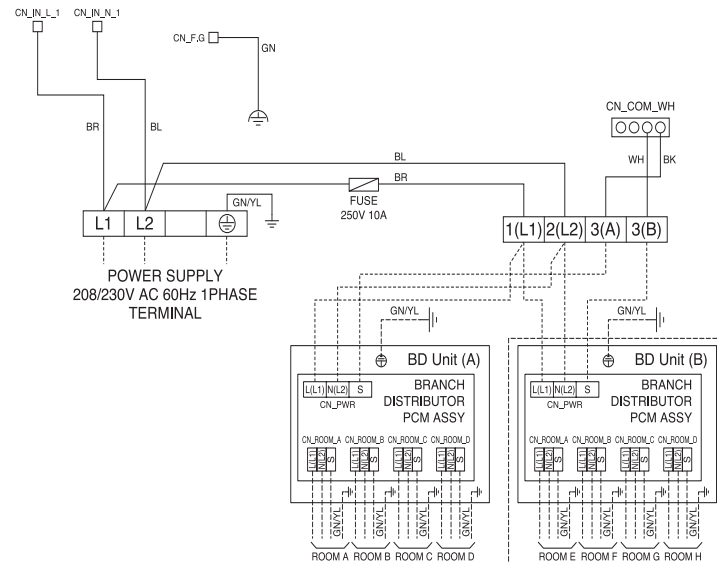

MULTIF / MULTIF MAX with LGRED Outdoor Unit Installation Manual

### Connecting the Communications / Connection (Power) Cable to the Branch Distributor Unit (Multi F MAX with LGRED Systems Only)

#### General Instructions

- Always connect power wiring / communications cable matching the branch distribution unit terminals to their respective indoor units (Example for three-port branch distribution unit PMBD3630: A, B, and C).
- Follow the instructions on the nameplates and connect wiring / cables of the outdoor unit and indoor units to the correct terminals. Always attach each ground wire separately to a grounding screw.
- After completion, secure wiring with wire clamps. Secure wiring firmly to the indoor unit.

Figure 92: Interior View of a Branch Distribution Unit (Three-Port PMBD3630 Example Shown).

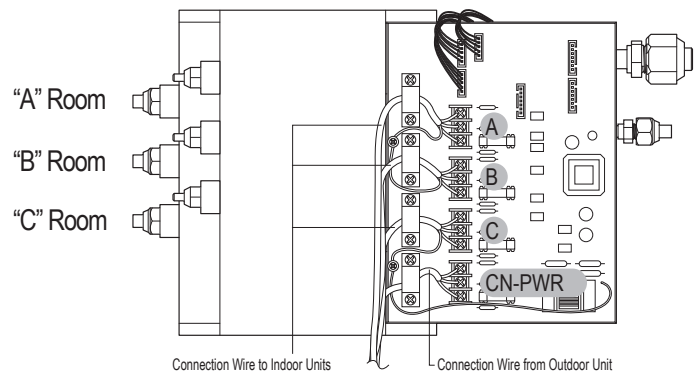

#### Branch Distribution Unit Wiring Connection Procedure

1. Remove the branch distribution unit control cover. Unscrew the two (2) screws, and slide the cover off the branch distribution frame following the arrows in the diagram (Step 1).
2. Draw the communications / connection (power) cable from the outdoor unit so there is enough length to connect to the terminals on the branch distribution unit. Secure a field-supplied conduit to the branch distribution unit using a field-supplied lock nut on the interior of the branch distribution unit frame (Step 2). Pull the communication / connection (power) cable through the conduit into the branch distribution unit.
3. Connect communications / connection (power) cable from the outdoor unit to the branch distribution unit terminals, and from the branch distribution unit terminals to the indoor unit terminals following the wiring diagram on the outdoor unit control cover (Step 3). Allow 11-13/16 inches of slack in the wire harness. Attach communications / connection (power) cable to the branch distribution unit with clamps at four (4) locations.
4. Replace the branch distribution unit control cover following the arrows in the diagram. Tighten the two (2) screws to finish (Step 4).

Figure 93: Branch Distribution Unit Wiring Steps.

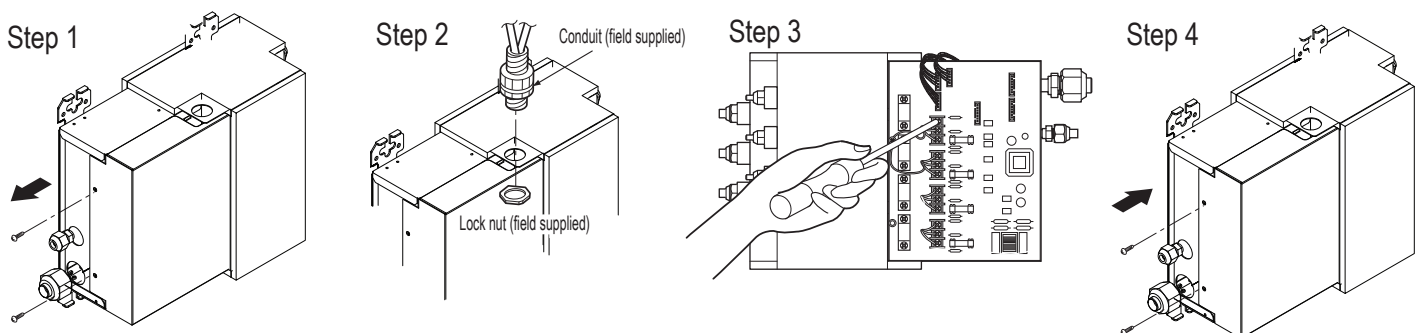

#### ⚠ WARNING

⊘ Do not use tapped wires, stand wires, extension cords, or starburst-type connections as they will cause overheating, fire, electric shock, physical injury or death.

#### Note:

Always refer to the circuit diagram on the inside of the outdoor unit control cover.

# ELECTRICAL

## Installation

### PI-485

PI-485 V-net Control Integration Board for Outdoor Units adapt Multi F / Multi F MAX with LGRED systems to a LG VRF system central protocol for integration with LG central controllers. The PI-485 is installed in the Multi F / Multi F MAX with LGRED outdoor unit. For more information on PI-485 installation, see the PI-485 installation manual.

Figure 95: PI-485 Installation Area in Multi F and Multi F MAX with LGRED Outdoor Units.

LMU180HHV, LMU240HHV, LMU300HHV

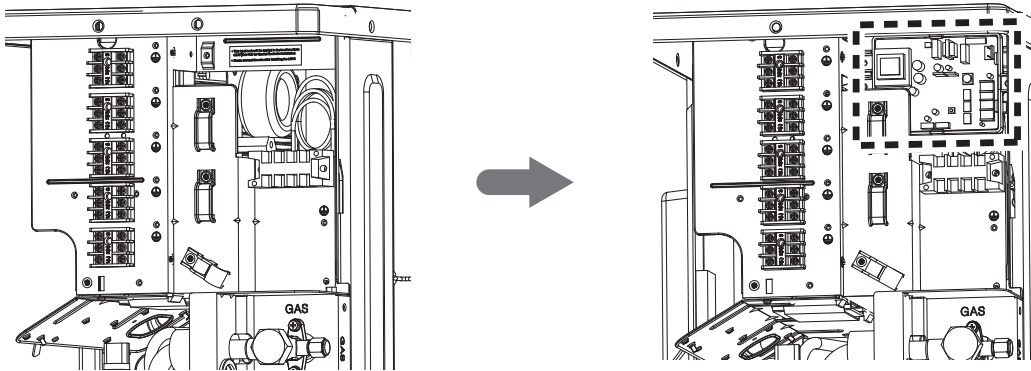

LMU360HHV, LMU420HHV

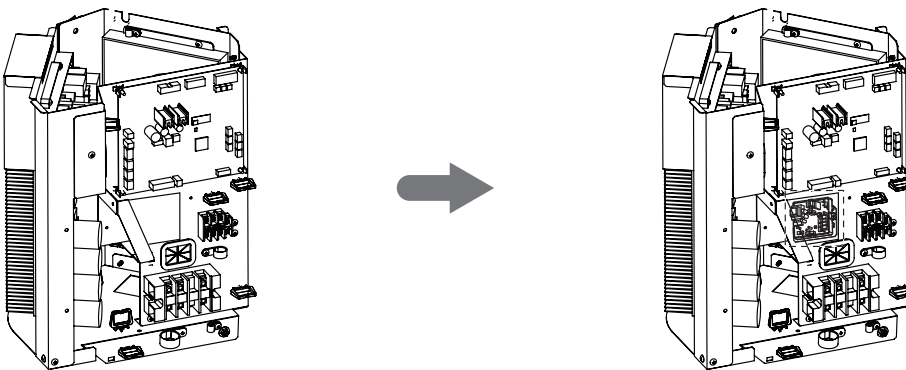
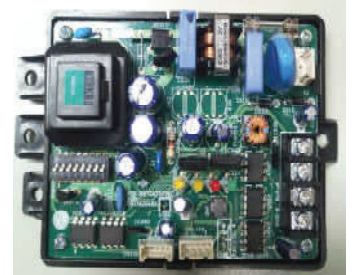

Figure 94: PI-485 Board (Appearance will differ depending on model).





### From Indoor Units to Remote Controllers

- Communication cable from indoor unit to remote controller(s) is to be LG supplied or field supplied 22 AWG, 3-conductor, twisted, stranded, unshielded. Wiring must comply with all applicable local and national codes.
- If using the LG supplied cable and the length needs to be extended, the LG Extension Kit (sold separately) must be used. A maximum of four (4) kits (up to 165 feet) can be used.
- Remote controllers have hardwired connections: SIG - 12V - GND (Comm.) terminals.
- Indoor unit controller connections depend on type of indoor unit being installed. Some indoor units use terminal block connections; other indoor units use Molex connections. See diagrams below for the two options. Refer to the wiring diagram schematic found in the indoor unit itself, or to the indoor unit wiring diagrams in the Engineering Manuals for more information.
- ⚠ NEVER splice, cut, or extend LG supplied cable with field provided cable. Always include enough cable to cover distance between the indoor unit and the remote controller.
- Set the indoor unit operating parameters using DIP switches, or by setting up the remote controller. Refer to the indoor unit installation manuals for more details.

Figure 96: One Example of Indoor Unit to Zone Controller Connection.

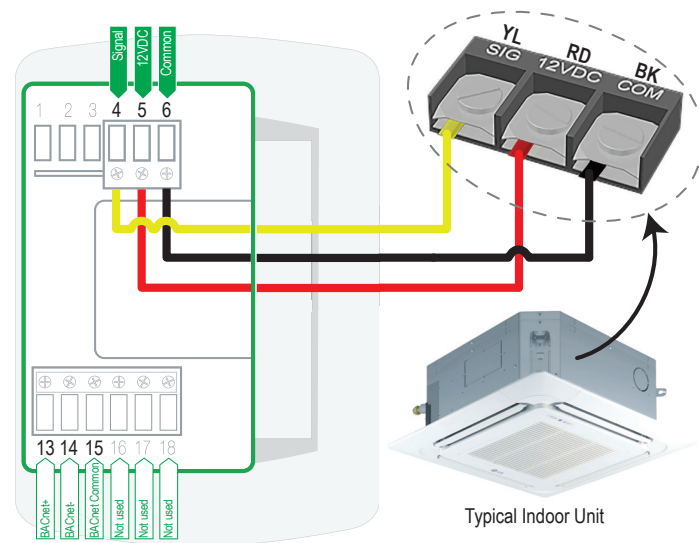

**Note:**

Cable connected to Zone Controller is the factory default connection.

Figure 97: Another Example of Indoor Unit to Zone Controller Connection.

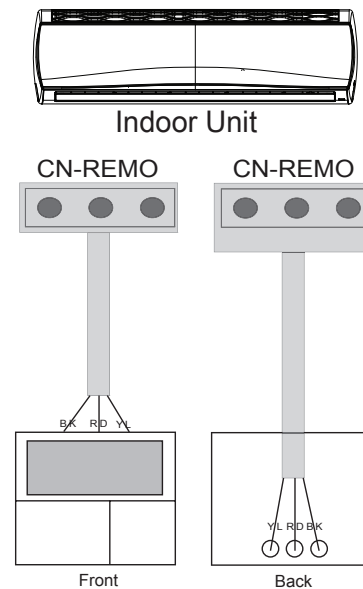

# ELECTRICAL

## Installation

### Between Multiple Indoor Units Operating as a Group (Group Control)

#### If any indoor units were specified to operate in unison:

- Before running cable, decide which indoor unit will be the “Master.” The other indoor units in that group will be designated as “Slave(s).” The zone controller will be connected to the “Master.”
- Set the pertinent DIP switch at each indoor unit to identify the Master and Slave(s). On wall mounted indoor unit models, set the assignment using the handheld remote controller.
- Use a daisy chain configuration and connect all of the group’s indoor units together starting at the “Master” unit.
- ⚠ NEVER splice, cut, or extend cable length with field provided cable. Always include enough cable to cover distance between all components.

#### For indoor units with hardwired connections SIG - 12V - GND (Comm.) terminals:

- From the controller to the master indoor unit, use 22 AWG, 3-conductor, twisted, stranded, unshielded. All wiring must comply with all applicable local / national codes.
- From the master indoor unit to the slave indoor unit(s), daisy chain using 22 AWG, 3-conductor, twisted, stranded, unshielded. All wiring must comply with all applicable local / national codes.
- (⚠ Do not attach wire to 12VDC terminal to the slave indoor units). All wiring must comply with all applicable local and national codes.
- ⚠ NEVER splice, cut, or extend cable length; always include enough cable to cover distance between all components.

#### For indoor units with CN-REMO connections:

Use one (or multiple) Group Control Kit(s) (sold separately) containing extension and Y-splitter cables. Use one (1) group control cable kit for each indoor unit in the group except for the last indoor unit. ⚠ NEVER splice, cut, or extend cable length with field provided cable.

#### Note:

- Cable connected to zone controller is the factory default connection.
- Indoor unit connections depend on indoor unit type.

#### General Specifications

- Wired remote controllers can be connected to all indoor unit types.
- Wireless controllers can be used in conjunction with wired remote controllers.
- A dry contact unit can be connected with a central controller simultaneously.
  - The master indoor unit is recognized by the dry contact unit and the central controller.
  - Group Control only available for indoor units manufactured after February 2009.
  - The central controller can control indoor units after setting the address of the master indoor unit only.
  - Slave indoor unit cannot be individually controlled by central controller.
  - Slave indoor unit will operate like master indoor unit.
- If an error occurs with the indoor unit, the error will be displayed on the wired remote controller.
- The following functions are available with group control:
  - Selection of operation options (operation/mode/set temperature)
  - Control of air flow rate (High/Medium/Low)

Figure 98: Example of Indoor Unit Group to Zone Controller Connections (Sig-12V-GND [Comm.] Terminal).

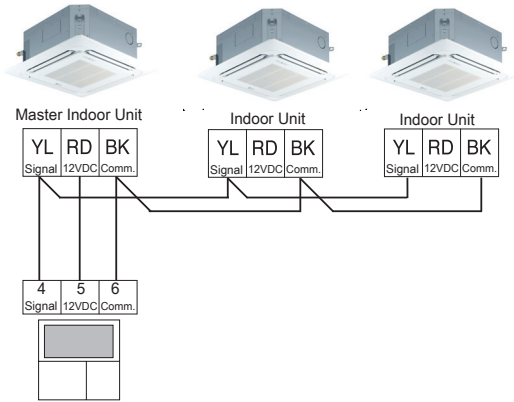

Figure 99: Example of Indoor Unit Group to Zone Controller Connections (CN-REMO).

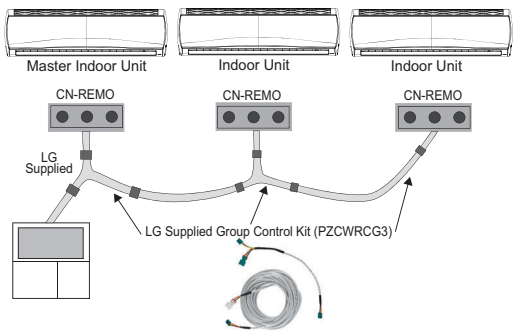

Table 33: Accessories for Some Group Control Applications.

Accessory	Model Number	Image
Wired Remote Group Control Cable Assembly, Required for connecting multiple indoor units to a control group	PZCWRG3	
Wired Remote/Wired Remote Extension Cable, Required for extending the distance between indoor units or remote controllers in a control group	PZCWRC1	

### Triple Leak / Pressure Test

After the refrigerant piping installation is complete, perform a triple leak / pressure test. Triple leak / pressure test is performed between the outdoor unit and indoor units (and branch distribution units [Multi F MAX with LGRED only]) to verify that refrigerant can flow through the system without danger of leaks or pressure losses. Air and moisture that is left in the piping can lead to undesirable results and can cause damage to the system. It is important to go through a complete leak / pressure cycle to be sure that the refrigerant piping is cleared out. This process will have to be repeated if any air or moisture be is found to remain in the piping.

#### Note:

Insufficient or incorrectly done air purging will lead to the following:

- Pressure in the system can rise.
- Operating current can rise.
- Inefficient cooling or heating mode capability.
- Moisture in the refrigerant circuit will freeze and block capillary tubing.
- Water can lead to corrosion of parts in the system.

#### ⚠ DANGER

Using combustible gases, including oxygen will result in fire or explosion, resulting in personal injury or death. Use inert gas (medical-grade dry nitrogen) when checking leaks, cleaning, installing/repairing pipes, etc. The use of at least 800 psig nitrogen regulator is required for safety.

#### Note:

- ⚠ Do not apply power to the system before performing a system leak test. There is a possibility that the EEV valve may close and isolate sections of the piping system, making the leak test inconclusive.
- ⚠ Never perform the leak test using refrigerant.
- To avoid nitrogen entering the refrigerant system in a liquid state, the top of the cylinder must be higher than its bottom (used in a vertical standing position) when the system is pressurized.
- Use only a leak-free gauge manifold set.
- Piping system must not be pressured to more than 550 psi. Pressures greater than 550 psi will damage the piping system and cause unit malfunction.

#### Triple Leak / Pressure Check Procedure

1. After the refrigerant piping installation is complete, open the isolation ball valves, if any, that may have been included in the piping system.
2. Verify that both the liquid and gas (vapor) suction line outdoor unit service ports are closed, and the stem head access caps are tight. The leak / pressure check is to be performed only to the refrigerant piping system, and all connected indoor units and branch distribution units (Multi F MAX with LGRED units only).
3. Remove the caps on both the liquid and gas (vapor) suction Schrader ports. Connect the (medical-grade dry) nitrogen cylinder regulator to a gauge manifold, then connect the gauge manifold to the Schrader ports on the service ports.
4. Perform the leak / pressure check at 150 psig for fifteen (15) minutes (standing pressure check).
5. Perform the leak / pressure check at 300 psig for thirty (30) minutes (standing pressure check).
6. Perform the leak / pressure check at 550 psig for one (1) hour to make sure the piping system is leak-free. After the gauge reading reaches 550 psig, isolate the system by first closing the gauge manifold, then close the nitrogen cylinder valve. Check the flared (and any brazed connections) for leaks by applying a bubble solution to all joints. Also test for leaks at both service valves.

Figure 100: Triple Leak / Pressure Test Diagram.

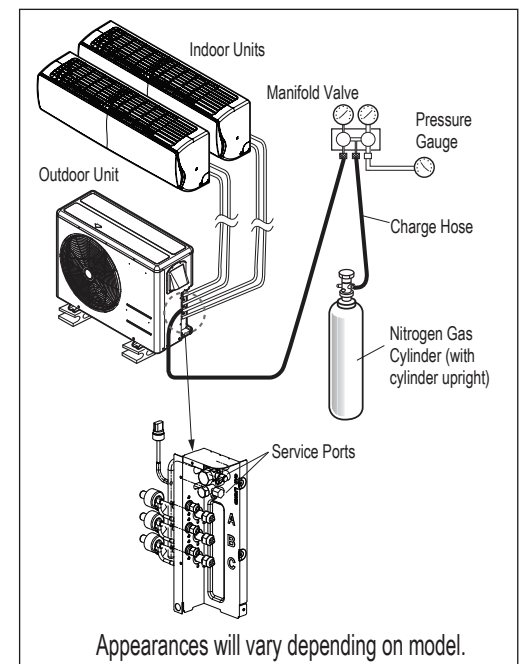

# FINAL INSTALLATION PROCEDURES

MULTI F WITH LGRED°  
MULTI F MAX

## Triple Leak / Pressure and Deep Evacuation Tests

### Triple Leak / Pressure Check Procedure, continued.

**Note:**

The bubble solution must be a solution designed for refrigerant leak testing. Common soap solution must  never be used on refrigerant piping as those contain chemicals that could corrode copper and brass, and cause product malfunction.

7. If the pressure does NOT drop for one (1) hour, the system passes the test.
8. If the pressure drops, there is a leak and it must be found. Remove the bubble solution with a clean cloth, repair the leak(s), and perform the leak / pressure check again.
9. After the system has been thoroughly tested and no leaks are found, depressurize by loosening the charging hose connector at the nitrogen cylinder regulator. When system pressure returns to normal, completely disconnect the charging hose from the cylinder, and release the nitrogen charge from all refrigerant piping. Wipe off any remaining bubble solution with a clean cloth.

### Deep Evacuation Procedure

On Multi F systems, after the leak / pressure check is complete, the deep evacuation procedure must be performed to the refrigerant piping and all connected indoor units. On Multi F MAX systems, the triple evacuation procedure (seen on page 75) must be performed. Deep evacuation must be performed through the Schrader ports on the outdoor unit service ports.

**Note:**



The triple evacuation procedure seen on page 75 is a best practices recommendation for Multi F systems, but mandatory for Multi F MAX systems.

**Note:**

For faster evacuation, the Schrader core can be removed, and an auxiliary service port can be used. Make sure to re-install the original Schrader core before operating the system.

- Deep evacuate through both the liquid and gas (vapor) suction Schrader ports on the outdoor unit service ports.
- The outdoor unit service valves must remain closed and the stem head access caps tight.  Do not open the outdoor unit service valves and release the factory refrigerant charge until trim charge is complete, and the system is ready to operate.
- Any field-installed ball valves in the refrigerant system (if used) must be open to ensure all piping is free and clear for deep evacuation on all piping and connected indoor units.

**Note:**

-  Do not apply power to the system before performing the deep evacuation procedure. There is a possibility that the EEV valve will close and isolate sections of the piping system, making the deep evacuation procedure inconclusive.
-  Never perform evacuation using refrigerant.
- Use only a vacuum pump that can reach 500 microns, vacuum rated hoses or copper tubing, and a leak-free gauge manifold set.
- Use only new vacuum pump oil from a properly sealed (unopened) container, and change oil in pump before EVERY use.
- Subsequent oil changes will be necessary after several hours of continuous operation; have extra oil on hand.
- Use a quality micron gauge in good operating order and install as far away from pump as possible.

### Deep Evacuation Procedure Steps

1. If this procedure is performed shortly after the leak / pressure test, the cap and core on the liquid and gas (vapor) suction Schrader ports must have already been removed, and the manifold must already be connected. If the procedure was not performed shortly after the leak / pressure test, make sure to remove the cap and core on the liquid and gas (vapor) suction Schrader ports. Verify that the service valves on the outdoor unit are closed, and the stem head access caps are tight.
2. Connect the gauge manifold along with the vacuum pump to the liquid and gas (vapor) suction Schrader ports (with core removed) using a vacuum hose. Open the gauge manifold and the vacuum pump valves.

### Deep Evacuation Procedure, continued.

3. Evacuate to static micron level  $\leq 500$  for at least one (1) hour.
4. Micron level must remain  $\leq 500$  for two (2) hours. If the vacuum gauge rises and stops, the system may contain moisture; therefore, it will be necessary to repeat the steps of vacuum break and drying.
5. After maintaining the system in vacuum for two (2) hours, check if the vacuum gauge rises or not. If it doesn't rise, then the system is properly evacuated.
6. Close manifold gauges.
7. Shut the valves before turning off and disconnecting the vacuum pump.

Figure 101: Evacuation Procedure Diagram.

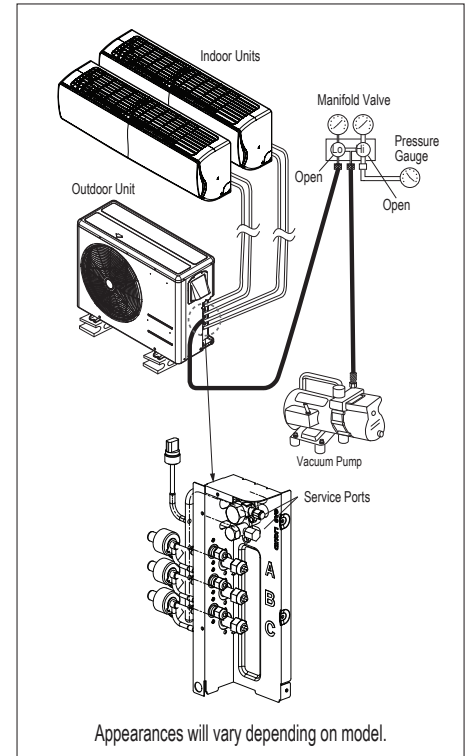

### Triple Evacuation Procedure

On Multi F MAX systems, after the leak / pressure check is complete, the triple evacuation procedure must be performed to the refrigerant piping and all connected indoor units / branch distribution units. ⚠ Do not just perform the deep evacuation procedure on Multi F MAX systems. The deep evacuation procedure is insufficient to fully evacuate the extensive piping systems on Multi F MAX products. Triple evacuation must be performed through the Schrader ports on the outdoor unit service ports.

#### Note:

The triple evacuation procedure is a best practices recommendation for Multi F systems, but mandatory for Multi F MAX systems.

#### Note:

For faster evacuation, the Schrader core can be removed, and an auxiliary service port can be used. Make sure to re-install the original Schrader core before operating the system.

- Evacuate through both the liquid and gas (vapor) suction Schrader ports on the outdoor unit service ports.
- The outdoor unit service valves must remain closed and the stem head access caps tight. ⚠ Do not open the outdoor unit service valves and release the factory refrigerant charge until trim charge is complete, and the system is ready to operate.
- Any field-installed ball valves in the refrigerant system (if used) must be open to ensure all piping is free and clear for evacuation on all piping and connected indoor units / branch distribution units.

#### Note:

- ⚠ Do not apply power to the system before performing the evacuation procedure. There is a possibility that the EEV valve may close and isolate sections of the piping system, making the evacuation procedure inconclusive.
- ⚠ Never perform evacuation using refrigerant.
- Use only a vacuum pump that can reach 500 microns, vacuum rated hoses or copper tubing, and a leak-free gauge manifold set.
- Use only new vacuum pump oil from a properly sealed (unopened) container, and change oil in pump before EVERY use.
- Subsequent oil changes will be necessary after several hours of continuous operation; have extra oil on hand.
- Use a quality micron gauge in good operating order and install as far away from pump as possible.



## Triple Evacuation Test

### Triple Evacuation Procedure Steps

1. If this procedure is performed shortly after the leak / pressure test, the cap and core on the liquid and gas (vapor) suction Schrader ports must have already been removed, and the manifold must already be connected. If the procedure was not performed shortly after the leak / pressure test, make sure to remove the cap and core on the liquid and gas (vapor) suction Schrader ports. Verify that the service valves on the outdoor unit are closed, and the stem head access caps are tight.
2. Connect the gauge manifold along with the vacuum pump to the liquid and gas (vapor) suction Schrader ports (with core removed) using a vacuum hose. Open the gauge manifold and the vacuum pump valves.

#### Note:

- After the vacuum pump is first operated, if hoses, manifold, and vacuum valves are leak free (and oil is not moisture laden), the gauge must read <100 microns within one (1) minute.
  -  Do not proceed if the gauge does not read <100 microns within one (1) minute. There is a leak in the hose, gauge manifold, or vacuum valve, and the equipment must be replaced.
3. Operate the vacuum pump and evacuate the system to the 2,000 micron level. Isolate the pump by closing the manifold gauges and the vacuum pump valve, and then watch the micron level. Micron level will rise a bit, but MUST eventually stop rising for fifteen (15) minutes.
    - If the micron level DOES NOT stop rising, there is a leak, and the leak test must be performed again.
    - If the micron level DOES rise above 2,000 micron, re-open the manifold gauges and the vacuum pump valve and continue evacuation back down to 2,000 micron level.
    - If the micron level holds at 2,000 micron, continue to step 4.
  4. Break vacuum with 50 psig nitrogen purge for an appropriate amount of time (this is to “sweep” moisture from piping).
  5. Purge nitrogen from the system until the pressure drops down to 1 to 3 psig.
  6. Evacuate to 1,000 micron level. Isolate the pump by closing the manifold gauges and the vacuum pump valve, and then watch the micron level. Micron level will rise a bit, but MUST eventually stop rising for fifteen (15) minutes.
    - If the micron level DOES NOT stop rising, there is a leak, and the leak test must be performed again.
    - If the micron level DOES rise above 1,000 micron, re-open the manifold gauges and the vacuum pump valve, and continue evacuation back down to 1,000 micron level.
    - If the micron level holds at 1,000 micron, continue to step 7.
  7. Break vacuum with 50 psig nitrogen purge for an appropriate amount of time.
  8. Purge nitrogen from the system until the pressure drops down to 1 to 3 psig.
  9. Evacuate to static micron level  $\leq 500$  for at least one (1) hour.
  10. Micron level must remain  $\leq 500$  for one (1) hour. If the vacuum gauge rises and stops, the system may contain moisture; therefore, it will be necessary to repeat the steps of vacuum break and drying.
  11. After maintaining the system in vacuum for one (1) hour, check if the vacuum gauge rises or not. If it doesn't rise, then the system is properly evacuated.
  12. Close manifold gauges.
  13. Shut the valves before turning off and disconnecting the vacuum pump.



LG Multi F and Multi F MAX with LGRED outdoor units ship from the factory with a charge of R410A refrigerant. A trim charge may need to be added to take into account additional piping length.

To determine the additional refrigerant that is needed, apply the formulas below, and record the results. If the total additional refrigerant charge value is a negative number, then an additional trim charge does not need to be added to the system.

Table 34: Outdoor Unit Factory Charge.

Outdoor Unit	Factory Charge oz. of R410A
LMU180HHV	98.8
LMU240HHV	112.8
LMU300HHV	112.8
LMU360HHV	197.5
LMU420HHV	197.5

### Multi F with LGRED Systems

$$\begin{aligned} \text{Additional charge (lbs.)} &= (\text{Installed Length of Branch [A]} - \text{Chargeless Pipe Length [L]}) \times a \\ &+ (\text{Installed Length of Branch [B]} - \text{Chargeless Pipe Length [L]}) \times a \\ &+ (\text{Installed Length of Branch [C]} - \text{Chargeless Pipe Length [L]}) \times a \\ &+ (\text{Installed Length of Branch [D]} - \text{Chargeless Pipe Length [L]}) \times a \\ &- \text{CF (Correction Factor)} \times 5.29 \end{aligned}$$

#### Note:

- Number of installed length of branches depends on the specifications of the outdoor unit model.
- CF = Maximum number of connectible indoor units – Total number of connected indoor units.

Table 35: Multi F with LGRED Outdoor Unit Piping Specifications.

Outdoor Unit Model	Min. to Max. Piping Length for One Branch (ft.)	Max. Total System Piping Length (ft.)	Chargeless Pipe Length per Branch (L) (ft.)	Piping Length (No Additional Refrigerant [ft])	Additional Charge Needed (a) (oz./ft.)
LMU180HHV	9.8 to 82	164	24.6	49.2	0.22
LMU240HHV	9.8 to 82	246.1	24.6	73.8	0.22
LMU300HHV	9.8 to 82	246.1	24.6	98.4	0.22

Figure 102: Multi F with LGRED Additional Refrigerant Charge Example.

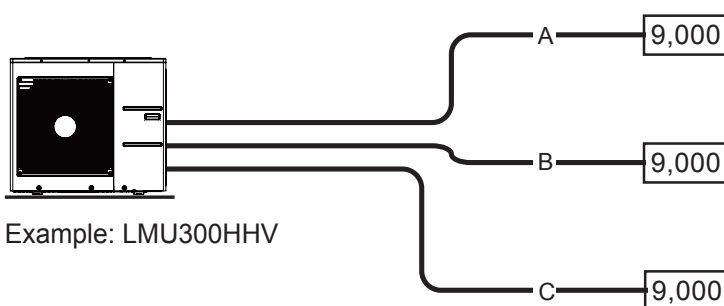

Each branch pipe  
A = 82 ft.  
B = 16 ft.  
C = 49 ft.

$$\begin{aligned} \text{Additional Charge} &= (82 - 24.6) \times 0.22 \\ &+ (16 - 24.6) \times 0.22 \\ &+ (49 - 24.6) \times 0.22 \\ &- (4 - 3) \times 5.29 \\ &= 10.82 \text{ oz.} \end{aligned}$$

# FINAL INSTALLATION PROCEDURES

MULTI F WITH LGRED<sup>®</sup>  
MULTI F MAX

## Refrigerant Charge

### Multi F MAX with LGRED Systems

Additional charge (lbs.) = (Total Main Piping Length [A] - Chargeless Pipe Length of Main Pipe [L]) x a  
 + (Installed Length of Branch [B1] - Chargeless Pipe Length [B]) x b  
 + (Installed Length of Branch [B2] - Chargeless Pipe Length [B]) x b  
 + (Installed Length of Branch [B3] - Chargeless Pipe Length [B]) x b ...  
 - CF (Correction Factor) x 3.53

#### Note:

- Number of installed length of branches depends on system specifications.
- CF = Maximum number of connectible indoor units - Total number of connected indoor units

Table 36: Multi F MAX with LGRED Outdoor Unit Piping Specifications.

Outdoor Unit Model	Main Piping Length		Branch Piping Length	
	Chargeless Pipe Length of Main Pipe (L) (ft.)	Additional Charge Needed (a) (oz./ft.)	Chargeless Pipe Length per Branch Pipe (B) (ft.)	Additional Charge Needed (b) (oz./ft.)
LMU360HHV	16.4	0.54	16.4	0.22
LMU420HHV	16.4	0.54	16.4	0.22

Figure 103: Multi F MAX with LGRED Additional Refrigerant Charge Example.

LMU420HHV

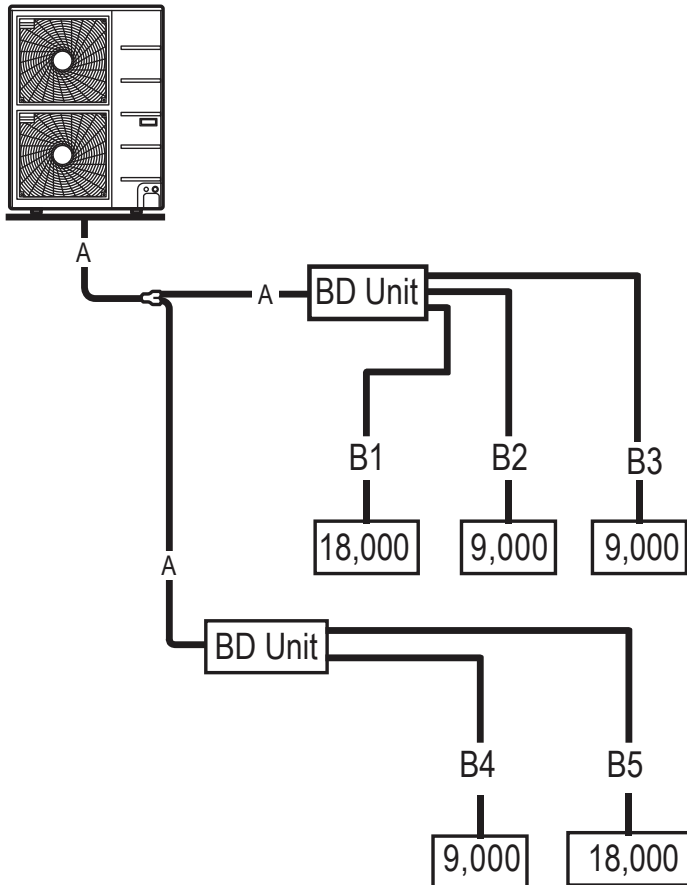

- Total main pipe (A) = 60 ft.
- Each branch pipe  
 B1 = 49 ft.  
 B2 = 17 ft.  
 B3 = 17 ft.  
 B4 = 10 ft.  
 B5 = 23 ft.

$$\begin{aligned}
 \text{Additional Charge} &= (60 - 16.4) \times 0.54 \\
 &+ (49 - 16.4) \times 0.22 \\
 &+ (17 - 16.4) \times 0.22 \\
 &+ (17 - 16.4) \times 0.22 \\
 &+ (10 - 16.4) \times 0.22 \\
 &+ (23 - 16.4) \times 0.22 \\
 &- (8 - 5) \times 3.53 \\
 &= 20.43 \text{ oz.}
 \end{aligned}$$

### Refrigerant Charge

1. Determine the refrigerant that is needed, applying the necessary formulas as outlined in the previous pages.
2. Connect the charging cylinder to the charge hose on the manifold valve.
3. Purge air from the charge hose by opening the valve at the bottom of the cylinder, and press the check valve on the manifold valve.
4. Confirm that the "Lo" knob of the manifold valve is open and charge the system with liquid refrigerant. (Because R-410A is a non-azeotrope refrigerant, it must be charged in the liquid state.)
  - If the required amount of refrigerant cannot be charged all at once, the refrigerant can be charged a little at a time (approximately 5.29 ounces) while the system operates in cooling. This procedure must be repeated until the entire amount of refrigerant gets charged into the system; perform once, then wait approximately one [1] minute before resuming.
5. Immediately disconnect the charge hose from the service port on the three-way valve. Stopping halfway allows the refrigerant to discharge.
  - If the system has been charged with liquid refrigerant while it operates, turn the system off before disconnecting the hose.
6. Mount the valve stem nuts and the service port nut. Use torque wrench to tighten the service port nut to a torque of 1.8 kg.m and check for leaks.

#### ⚠ WARNING

When installing or relocating the outdoor unit, make sure that no substance other than the specified refrigerant (R410A) enters the refrigerant circuit. The presence of foreign substances such as air can cause an abnormal pressure rise and will result in explosion and physical injury.

Figure 104: Charging the Refrigerant.

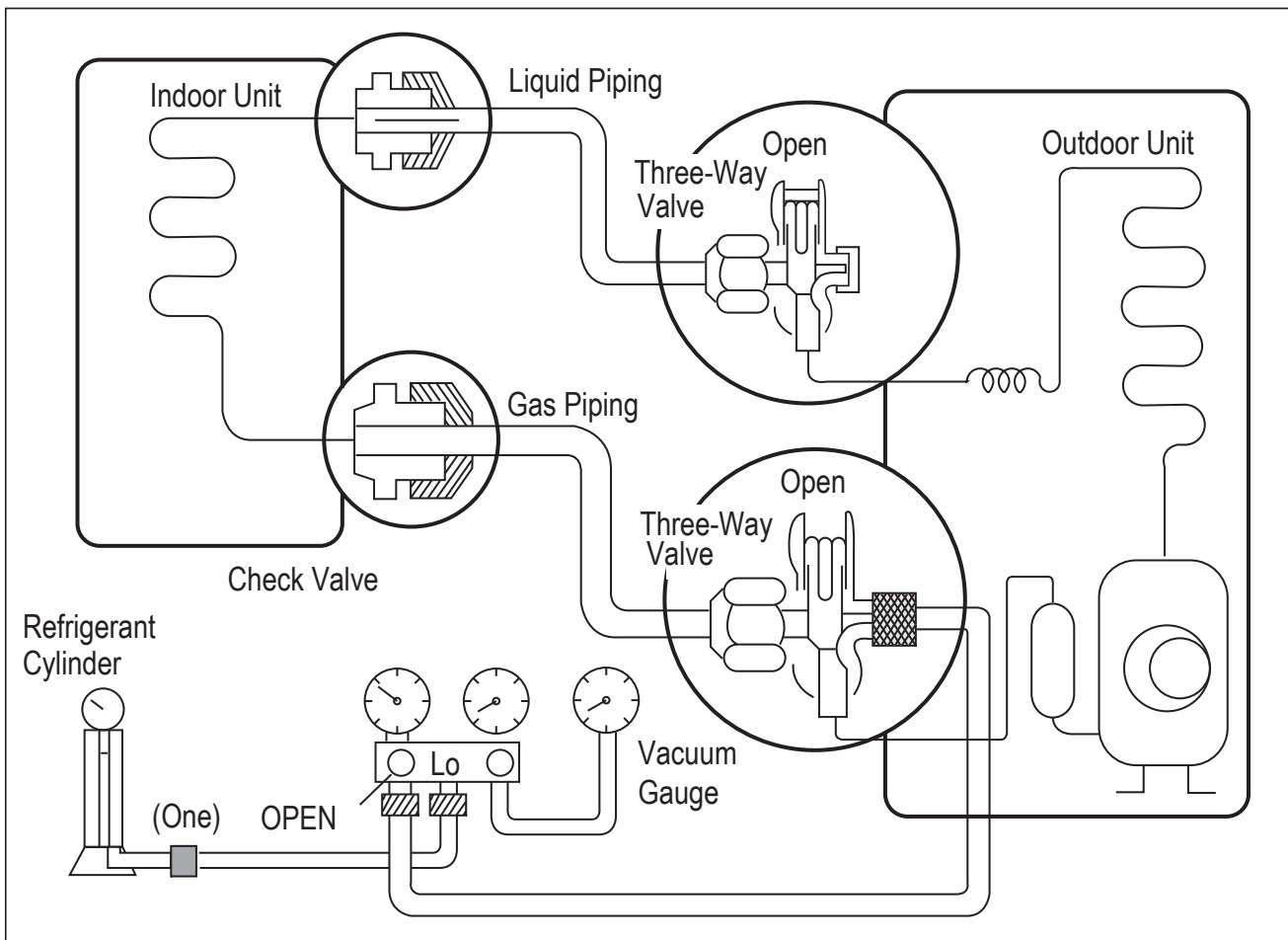

### Cautions for Refrigerant Leaks / Introduction

ASHRAE Standards 15 and 34 offer guidelines that address refrigerant safety and the maximum allowable concentration of refrigerant in an occupied space. Refrigerant will dissipate into the atmosphere, but a certain volume of air is required for this to occur safely. For R410A refrigerant, the maximum allowable concentration is 0.026 lbs./ft<sup>3</sup> per 1,000 ft<sup>3</sup> of air in an occupied space. Buildings with twenty-four (24) hour occupancy allow half of that concentration.<sup>1</sup>

ASHRAE Standards 15 and 34 assume that if a system develops a leak, its entire refrigerant charge will dump into the area where the leak occurs. To meet ASHRAE Standards 15 and 34, calculate the refrigerant concentration that will occur in the smallest room volume on the system, and compare the results to the maximum allowable concentration number (see below for information on how to calculate the refrigerant concentration).<sup>1</sup> Also consult state and local codes in regards to refrigerant safety.

#### **⚠ WARNING**

Verify the maximum refrigerant concentration level in the space where the indoor unit will be mounted meets the concentration limit for the application. If the refrigerant leaks and safety limits are exceeded, it could result in personal injuries or death from oxygen depletion.

#### **Note:**

Take appropriate actions at the end of HVAC equipment life to recover, recycle, reclaim or destroy R410A refrigerant according to applicable US EPA rules.

To calculate the potential refrigerant concentration level (RCL):

1. Measure the occupied space dimensions (in feet).
2. Calculate the cubic foot volume of air in the smallest occupied space. (To obtain a detailed overview of the RCL, perform the same calculations to the second smallest zone, the third smallest zone until the RCL is obtained for all zones. Also, pay special attention to areas such as basements, etc., where refrigerant cannot dissipate easily.)
3. Divide the refrigerant charge of the Multi Zone system serving the area in pounds by the results of step 1.
4. If the calculation indicates that the potential refrigerant concentration level is higher than the allowed RCL, increase the cubic volume of the smallest occupied space or modify the piping system design.
5. The allowable RCL limit for most applications must be equal to or less than 0.026 lbs./ft<sup>3</sup>. However, in special occupied spaces, such as hospitals and nursing homes, where occupants will have limited mobility, the allowable RCL limit is cut in half. See ASHRAE Standard 34 and local codes for detailed information.<sup>1</sup>

Figure 105: Example of R410A Refrigerant Leak Location.

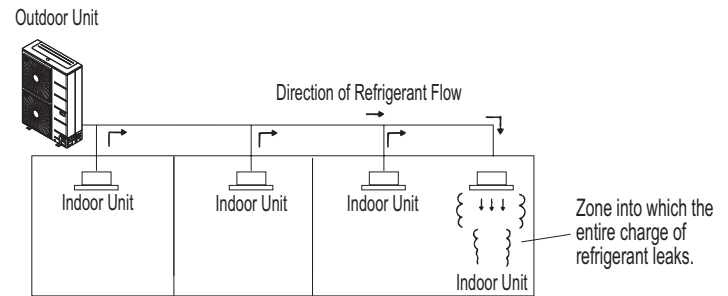

### Refrigerant Concentration Limit (RCL) Calculations

To calculate total refrigerant amount per system:

<b>Amount of Factory-Charged Refrigerant per Outdoor Unit</b>	<b>+</b>	<b>Amount of Additional Refrigerant Trim Charge</b>	<b>=</b>	<b>Total System Refrigerant Charge</b>
---	----------	---	----------	--

$$\text{RCL (lbs./ft}^3\text{)} = \frac{\text{Total System Refrigerant Charge (lbs.)}}{\text{Volume of Smallest Occupied Space (ft}^3\text{)}}$$

<sup>1</sup>American Society of Heating, Refrigeration and Air Conditioning Engineers, Inc. (ASHRAE). Atlanta, GA. ASHRAE, Inc. Information about ASHRAE Standard 15 / 34 and addenda current as of the date of this publication.

To determine the volume of an occupied space, the designer must also determine which ones are connected, not connected, or ventilated (refer to Standard 34).

If the calculated RCL is above the allowable limit, there are two primary methods used to lower the RCL:

1. Increase the volume of the occupied space.
2. Decrease the size of the refrigerant charge.

Per Standard 34-2007, acceptable methods used to increase the volume of an occupied space include:

- Install transfer ducts between rooms.
- Undercut and overcut doors (partitions  $\leq 0.15\%$  of cubic volume of space within a zone).
- Add an opening without a door (partitions  $\leq 0.15\%$  of cubic volume of space within a zone).
- Include ventilation grilles in doors; include ventilation inlets / outlets (partitions  $\leq 0.15\%$  of cubic volume of space within a zone).
- Include the area above the ceiling as part of the return or supply air path (partitions  $\leq 0.15\%$  of cubic volume of space within a zone).
- Install a mechanical ventilator linked to a gas leak detector.
- Change the indoor unit type (wall mounted to ceiling cassette) / position.

Figure 106: Examples of Zones.

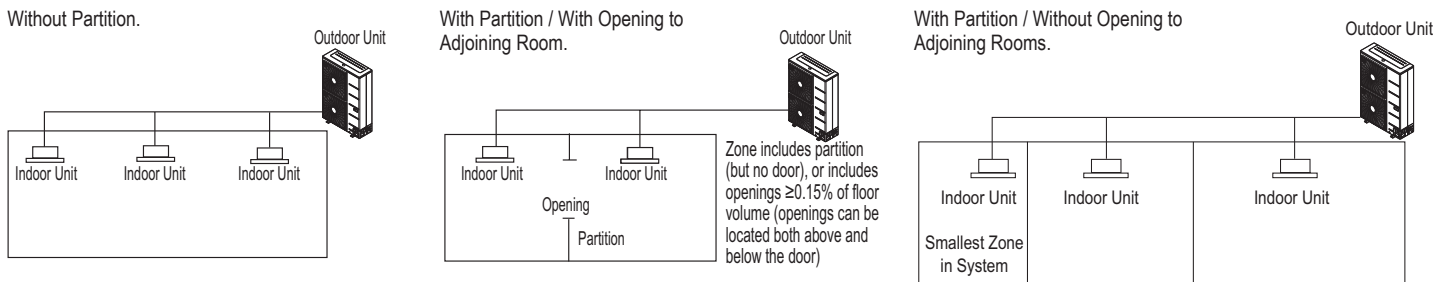
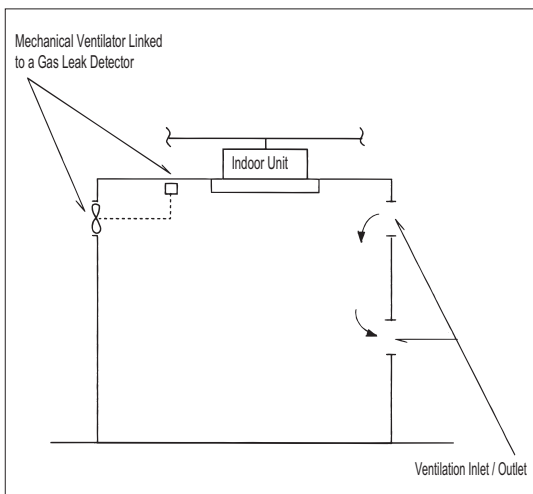

Figure 107: Example of Acceptable Ventilation Methods.



### Note:

See also the LG HVAC Building Ventilation Guide on [www.lghvac.com](http://www.lghvac.com).

## Test Run

### Test Run

After the triple leak / pressure and evacuation procedures are complete, perform a test run.

### Before the Test Run

1. Check that all condensate tubing, refrigerant piping and power wiring, and communication / connection (power) cables are properly connected.
2. Make sure that the gas and liquid service valves are fully open.

### Test Run Procedure

1. Operate the system in cooling mode for 15 to 20 minutes.
2. Evaluate performance as the system runs, verifying the outdoor unit, and all indoor units and branch distribution units (Multi F MAX with LGRED systems only) are working properly. Make notes as needed to address any issues that might be found.
  - Check the system refrigerant charge:
    - Measure the pressure from the gas side service valve.
    - Measure the indoor unit inlet and outlet air temperatures. Verify the difference between the intake temperature and the discharge is more than 15°F.
    - See table below for the optimum condition of the gas side pressure (again, system is in cooling mode).

Table 37: Optimum Conditions of the Gas Side Pressure.

Refrigerant Type	Outside Ambient Temperature	Gas Side Service Valve Pressure
R410A	95°F	120~135 psig

### Note:

If the pressure is >135 psig, the system is most likely overcharged, and refrigerant must be removed. If the pressure is <120 psig, the system is most likely undercharged and refrigerant must be added.

### Installing the Remote Controller Batteries

As part of the test run, the batteries need to be inserted into the remote controller, and the remote controller will need to be powered on to operate the indoor units (depending on the indoor units included in the system). To insert the batteries follow the steps below. For information on using the remote controller, refer to its owner's manual.

1. The remote controller needs two (2) AAA (1.5V) batteries for operation. ⚠ Do not use rechargeable batteries. Remove the battery cover from the back of the remote controller by pushing downward on the tab at the top of the battery cover and then lift up to remove.
2. Insert the two new batteries. Align batteries by the (+) and (-) sides (the interior battery compartment of the remote controller will have clear markings for the (+) and (-) placement).
3. Verify that the batteries have "clicked" into the compartment and are firmly engaged with the contacts on either side.
4. Reattach the back cover of the remote controller.
5. Proceed with powering on the remote controller and usage as needed.

Figure 108: Piping Connection on the Outdoor Unit (Will Differ Depending on Outdoor Unit Model).

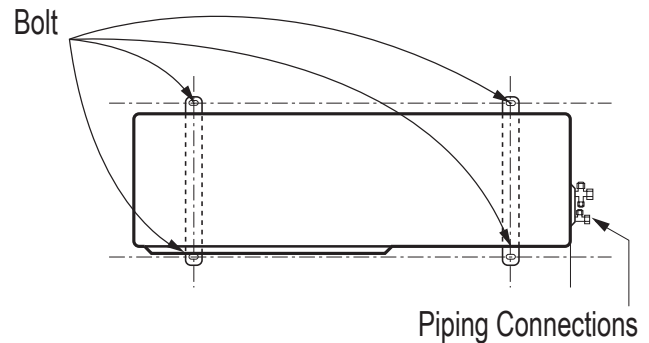

Figure 109: Inlet and Outlet Temperature Locations on Various Indoor Units.

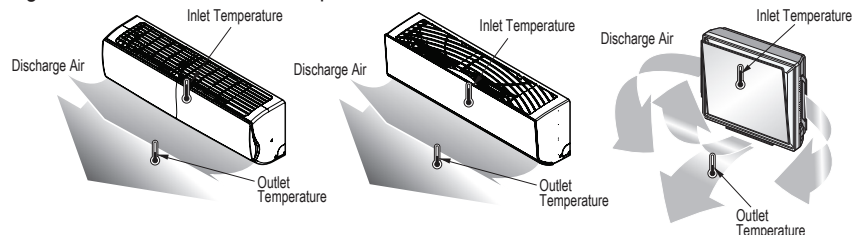
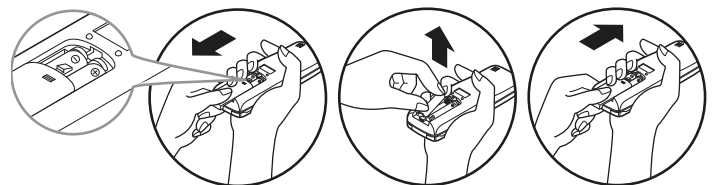

Figure 110: Installing the Remote Controller Batteries.





### Outdoor Unit DIP Switch Settings

System must be powered off, and then turned back on to apply DIP switch settings.

#### ⚠ WARNING

Turn off the circuit breaker or shut off the power source of the product before setting the DIP switch. There is risk of physical injury or death due to electric shock.

#### Note:

- Unless the applicable DIP switch is set properly, the system will not work.
- If a specific function is desired, request that the installer set the appropriate DIP switch during installation.
- Only the first four DIP switches are functional on the LMU360 and 420HHV.

Figure 111: LMU180, 240, 300HHV Outdoor Unit DIP Switches (in Normal Operation Setting).

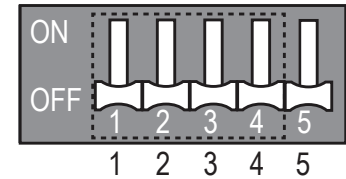

Figure 112: LMU360, 420HHV Outdoor Unit DIP Switches (in Normal Operation Setting).

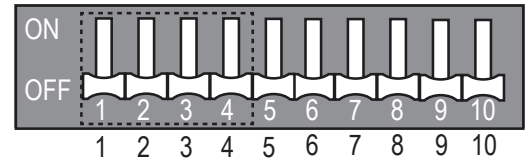

Table 38: DIP Switch Settings and Functionalities.

DIP Switch Setting	Function
	Normal Operation (No Function)
	Forced Cooling Operation
	Wiring Error Check
	Reducing Power Consumption (Step 1)
	Reducing Power Consumption (Step 2)
	Mode Lock (Cooling)
	Mode Lock (Heating)
	Night Quiet Mode (Step 1)
	Night Quiet Mode (Step 2)
	Mode Lock (Cooling) + Night Quiet Mode (Step 1)
	Mode Lock (Cooling) + Night Quiet Mode (Step 2)
	Reducing Power Consumption (Step 1) with Mode Lock (Cooling)
	Reducing Power Consumption (Step 2) with Mode Lock (Cooling)
	Reducing Power Consumption (Step 1) with Mode Lock (Heating)
	Reducing Power Consumption (Step 2) with Mode Lock (Heating)

### Location of DIP Switches on Multi F and Multi F MAX Outdoor Units

Figure 113: Multi F with LGRED (LMU180-240-300HHV) Outdoor Unit DIP Switch Locations.

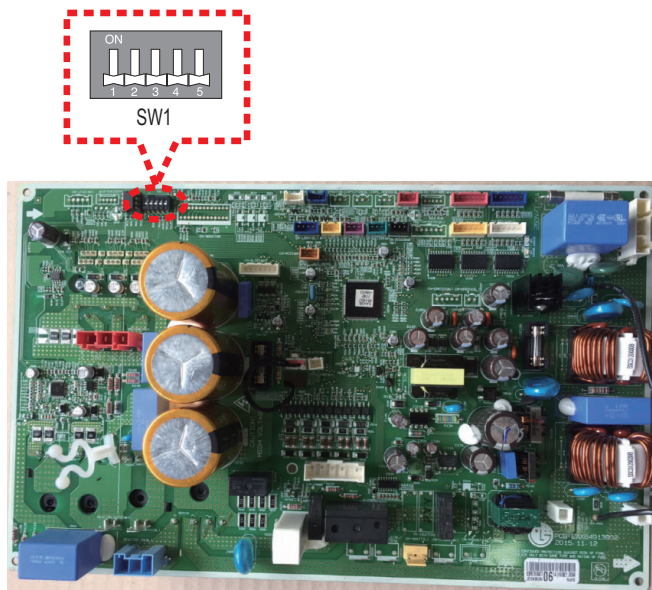
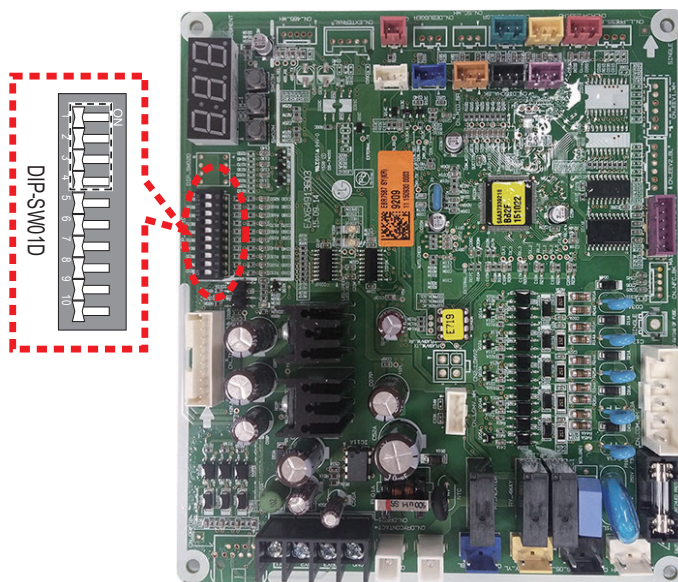

Figure 114: Multi F MAX with LGRED (LMU360-420HHV) Outdoor Unit DIP Switch Locations.



### Forced Cooling Operation Function

Use to add refrigerant to the system when outside ambient temperatures are cool (ex.: winter).

1. Shut power down to the system.
2. Set DIP Switch 1 to ON.
3. Turn power on to the system.
4. Verify that the Red LED on the outdoor unit PCB is ON (indicates indoor units are in forced cooling operation).
5. Add refrigerant.

#### Note:

- If the green LED light on the outdoor unit PCB is ON, it indicates the compressor is OFF due to low pressure in the system.
- Turn DIP Switch 1 to OFF after finishing (Normal Operation setting).
- Only the first four DIP switches are functional on the LMU360, 420HHV.

Figure 115: LMU180-240-300HHV Forced Cooling DIP Switch Setting.

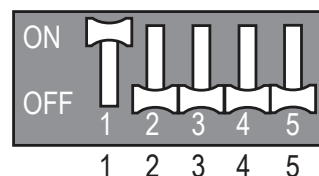
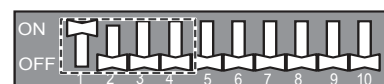

Figure 116: LMU360-420HHV Forced Cooling DIP Switch Setting.



### Wiring Error Check

Use to verify if wiring is properly installed.

1. Shut power down to the system.
2. Set DIP Switch 2 to ON.
3. Turn power on to the system.
4. Check if the Red and Green LEDs on the outdoor unit PCB are ON (indicate indoor units are in forced operation mode).
5. If the wiring is correctly installed, the Green LED will light up. If the wiring is incorrectly installed, the Red and Green LEDs will blink, indicating which part of the system is in error.
  - Red LED = Piping Number
  - Green LED = Wiring Number (Room)

Example: If the Red LED blinks twice and the Green LED blinks three times, the second piping to the third room is in error (see right).

#### Note:

- If the indoor unit(s) are not communicating properly to the outdoor unit, the Wiring Error Check cannot operate correctly.
- Only the part of the system in error will be displayed. System will operate correctly after the error is fixed.
- If outdoor and indoor temperatures are too low (ex.: winter), the wiring error check function will not operate (Red LED is ON).
- Turn DIP Switch 2 to OFF after finishing (Normal Operation setting).
- Only the first four DIP switches are functional on the LMU360, 420HHV.

### Reducing Power Consumption

Enables more efficient system operation by reducing the maximum power consumption value (reducing the MCA).

1. Shut power down to the system.
2. For Step 1, set only DIP Switch 3 to ON.
3. For Step 2, set only DIP Switch 4 to ON.
4. Turn power on to the system.

Table 39: Reducing Power Consumption Current Levels.

Phase	1Ø	
Model	Multi F with LGRED LMU180HHV, LMU240HHV, LMU300HHV	Multi F MAX with LGRED LMU360HHV, LMU420HHV
Step 1 (A)	12	22
Step 2 (A)	10	21

#### Note:

- Reduced Power Consumption reduces outdoor unit capacity.
- Only the first four DIP switches are functional on the LMU360, 420HHV.

Figure 117: LMU180-240-300HHV Wiring Error Check DIP Switch Setting.

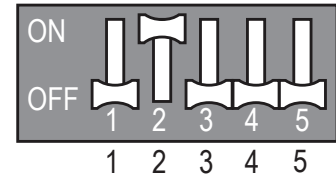

Figure 118: LMU360-420HHV Wiring Error Check Example.

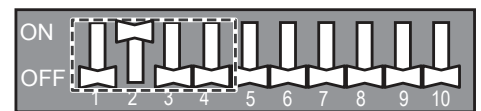

Figure 119: Wiring Error Check Example.

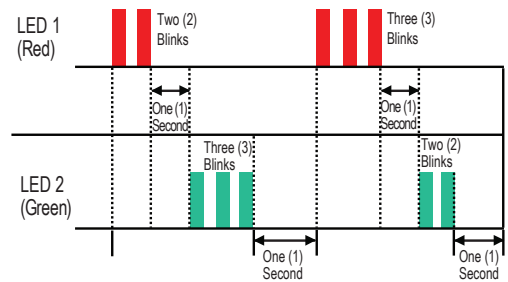

Figure 120: Reducing Power Consumption Chart.

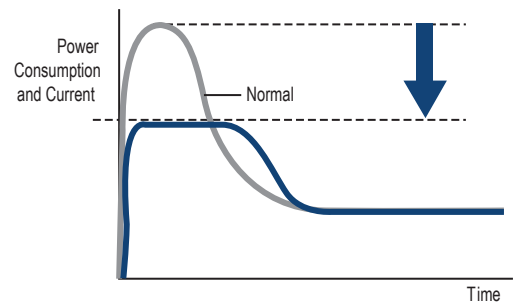

Figure 121: LMU180-240-300HHV Reducing Power Consumption DIP Switch Settings.

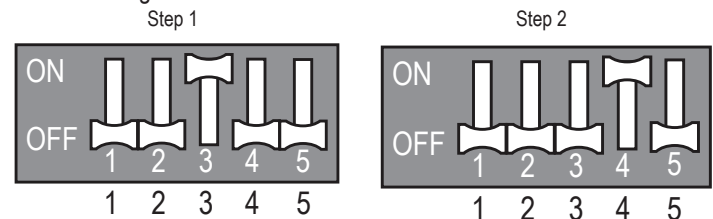
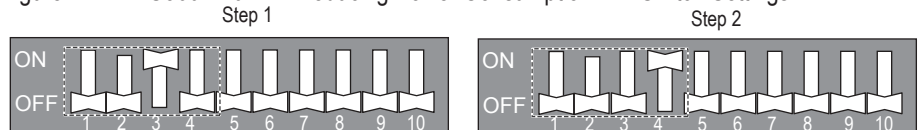

Figure 122: LMU360-420HHV Reducing Power Consumption DIP Switch Settings.



# FINAL INSTALLATION PROCEDURES

## DIP Switch Settings for Optional Modes

### Reducing Power Consumption with Mode Lock

Enables more efficient system operation by lowering the maximum power consumption value, as well as locks the mode of operation (Example: In a cooling-only server room application where permission to adjust the system mode is highly limited). Changing modes can cause a change in compressor frequency, which would cause problems with the setting. As such, if this mode is used, it is locked in either cooling or heating. The function is rarely, if ever, used.

1. Shut power down to the system.
2. Set DIP Switches as indicated below, following the steps and chosen mode.
3. Turn power on to the system.

**Note:**

Only the first four DIP switches are functional on the LMU360, 420HHV.

Figure 123: LMU180-240-300HHV Saving Power Consumption with Mode Lock DIP Switch Settings.

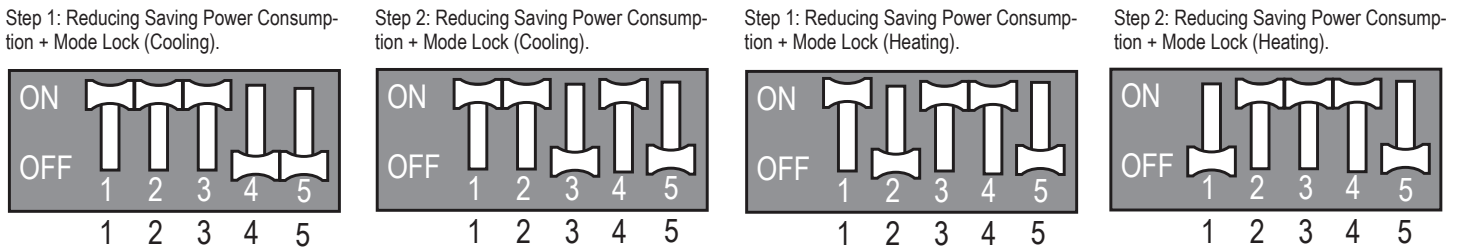
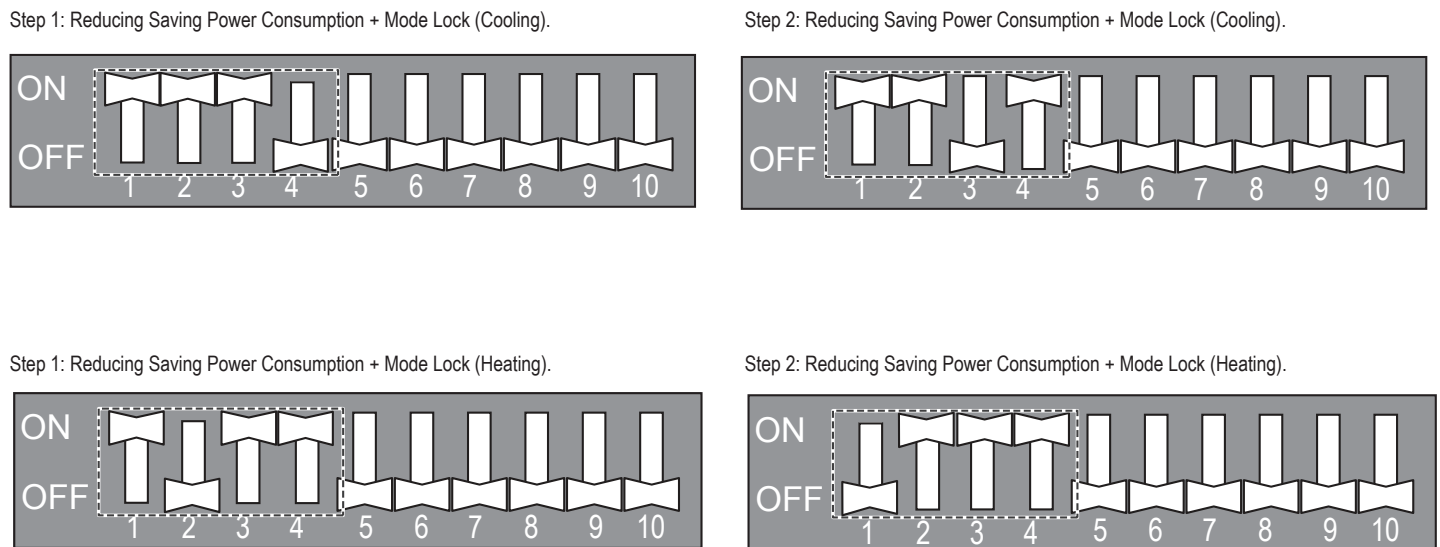

Figure 124: LMU360-420HHV Saving Power Consumption with Mode Lock DIP Switch Settings.



### Night Quiet Mode

Lowers the operation sound of the outdoor unit by changing the compressor frequency and fan speeds. Night quiet mode initiates eight (8) hours after the highest outdoor air temperature is measured, then is active for nine (9) hours.

1. Shut power down to the system.
2. For Step 1, set only DIP Switches 1 and 4 to ON.
3. For Step 2, set only DIP Switches 2 and 3 to ON.
4. Turn power on to the system.

**Note:**

Operation sound: Step 1 > Step 2.

Figure 125: LMU180-240-300HHV Night Quiet Mode DIP Switch Settings.

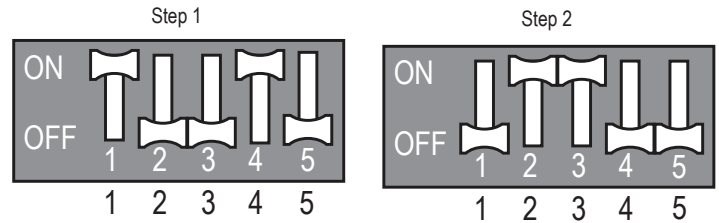
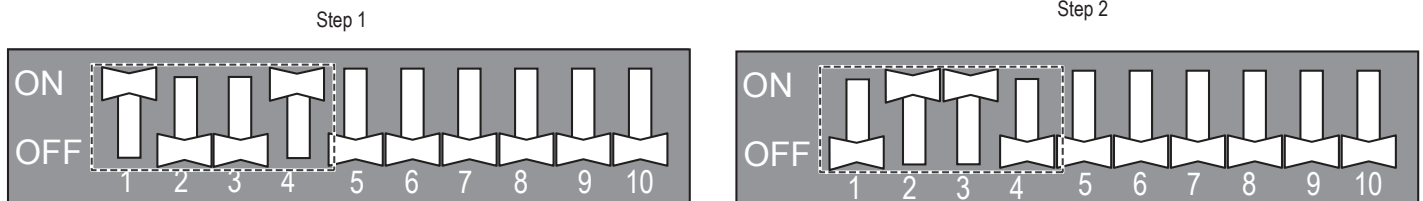

Figure 126: LMU360-420HHV Night Quiet Mode DIP Switch Settings.



### Mode Lock

Prevents mixed mode operation (mode change) in applications where only one mode is necessary.

1. Shut power down to the system.
2. For Only Cooling Mode Lock, set only DIP Switches 1 and 2 to ON. For Only Heating Mode Lock, set only DIP Switches 3 and 4 to ON.
3. Turn power on to the system.

Figure 127: LMU180-240-300HHV Mode Lock DIP Switch Settings.

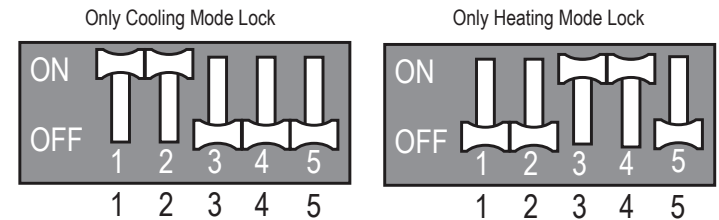
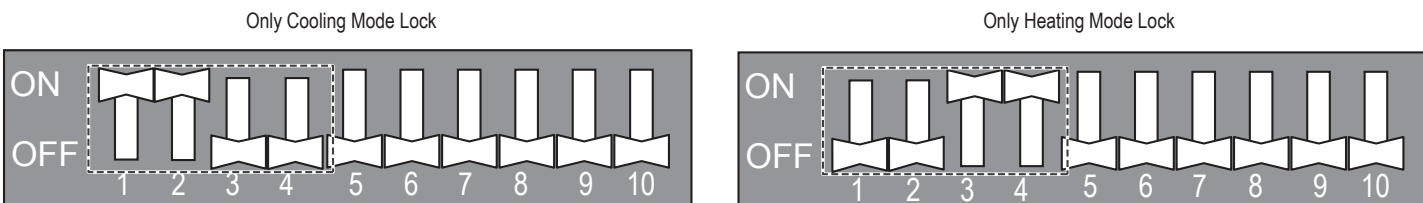

Figure 128: LMU360-420HHV Mode Lock DIP Switch Settings.



**Note:**

Only the first four DIP switches are functional on the LMU360-420HHV.



# FINAL INSTALLATION PROCEDURES

MULTI F WITH LGRED<sup>®</sup>  
MULTI F MAX

## DIP Switch Settings for Optional Modes

MULTI F / MULTI F MAX with LGRED Outdoor Unit Installation Manual

### Night Quiet Mode with Mode Lock

Lowers the operation sound of the outdoor unit by changing the compressor frequency and fan speeds, as well as locks the mode of operation. Changing modes can cause a change in compressor frequency, which would cause problems with the setting. As such, if this mode is used, it is locked in either cooling or heating. The function is rarely, if ever, used. Night quiet mode initiates eight (8) hours after the highest outdoor air temperature is measured, then is active for nine (9) hours.

1. Shut power down to the system.
2. For Step 1, set only DIP Switches 2 and 4 to ON.
3. For Step 2, set DIP Switches 1 and 3 to ON.
4. Turn power on to the system.

Figure 129: LMU180-240-300HHV Night Quiet Mode with Mode Lock DIP Switch Settings.

Step 1: Night Quiet Mode + Mode Lock (Cooling)

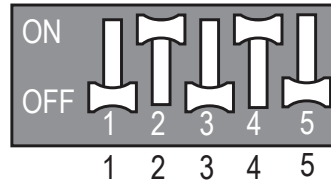

Step 2: Reducing Saving Power Consumption + Mode Lock (Cooling)

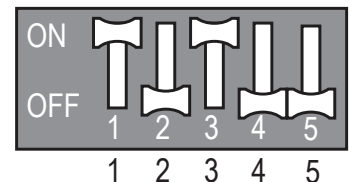
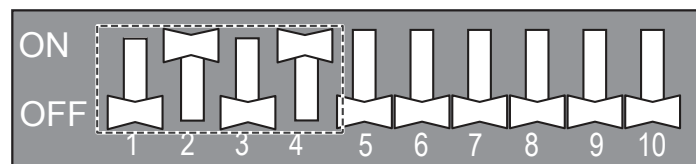
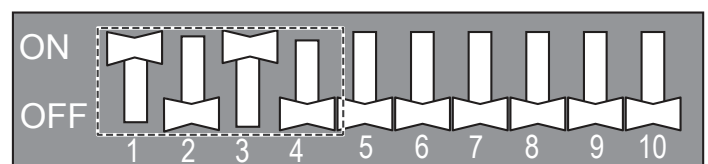

Figure 130: LMU360-420HHV Night Quiet Mode with Mode Lock DIP Switch Settings.

Step 1: Night Quiet Mode + Mode Lock (Cooling)



Step 2: Reducing Saving Power Consumption + Mode Lock (Cooling)



**Note:**

- If compressor frequency and fan speed are decreased, cooling capacity may also decrease.
- Night Quiet Mode can only be used when system is in cooling operation.
- Change the DIP switches if Night Quiet Mode is no longer desired.
- If indoor unit operation is set by the fan speed "Power", Night Quiet Mode will not function until fan speed "Power" is changed.
- Only the first four DIP switches are functional on the LMU360-420HHV.

### PCB Display (Multi F with LGRED LMU360HHV and LMU420HHV Models Only)

For Multi F MAX with LGRED LMU360HHV and LMU420HHV outdoor units, the cycle data can be checked without using LG Monitoring View (LGMV) Diagnostic Software by pushing TACT-SW1. See below for the types of cycle information that will be displayed in LGMV. After first page is displayed, the second page will be subsequently displayed.

**⚠ WARNING**

Protect fingers / hands with a non-conducting material before pushing TACT-SW1. There is risk of physical injury or death due to electric shock.

Figure 131: Location of TACT-SW1.

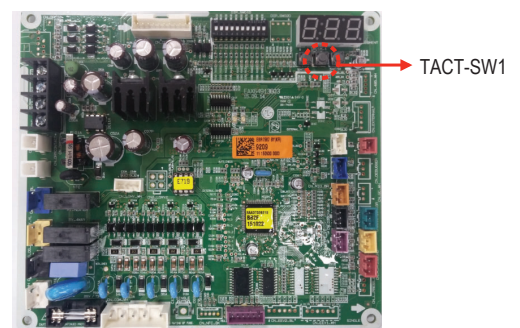

Table 40: PCB Display Information.

TACT-SW1 No. of Pushes	Description	Display		
		Example	First Page	Second Page
One (1) Time	Low Pressure	890kpa	"LP"	"89"
Two (2) Times	High Pressure	2,900kpa	"HP"	"290"
Three (3) Times	Discharge Temperature	85°C	"DS"	"85"
Four (4) Times	Condenser Outlet Temperature	-10°C	"CS"	"-10"
Five (5) Times	Suction Temperature	-10°C	"SS"	"-10"
Six (6) Times	Outdoor Unit Air Temperature	-10°C	"AS"	"-10"
Seven (7) Times	Current	15A	"A"	"15"
Eight (8) Times	Voltage	230V	"V"	"230"
Nine (9) Times	Compressor Hz	100Hz	"F"	"100"
Ten (10) Times	DC Link Voltage	230V	"dc"	"230"





**WARNING** Please refer to the Safety Precautions on pages 4-7 for more detail to prevent injury or death regarding the operation and service troubleshooting of the Multi F / Multi F MAX with LGRED product.

## Troubleshooting Using Error Codes

Refer to the tables below and on the next page for error codes that are generated from the indoor and outdoor units. These codes indicate different types of unit failures, assist in self-diagnosis, are the most common that will manifest through these units. Error codes are displayed on indoor unit LEDs, wired remote controllers, the outdoor unit PCB, and through LG Monitoring View (LGMV) diagnostic software.

Systems may generate additional codes not listed here. Contact LG Support if these types of errors are seen and a simple power down and boot up has not corrected the issue. ⚠ Do not attempt to fix the system yourself.

- If two or more errors occur simultaneously, the highest error code number is displayed first.
- After error is resolved, the error code does not display.

### Decoding the Error Display

See images and table below for indoor unit error codes, location of LEDs, and operation status.

The first and second number on the LED indicates error number. Example: 21 = LED1 (Red light) 2x blink, LED2 (Green light) 1x blink.

### Error Code Nomenclature Definitions

- MICOM: Non-volatile memory chip where unit setup information is stored.
- EEPROM: Non-volatile memory chip where device identification, size, and factory defined default component operating parameters are stored.

Figure 132: Example of Standard Wall-Mounted Indoor Unit LEDs.

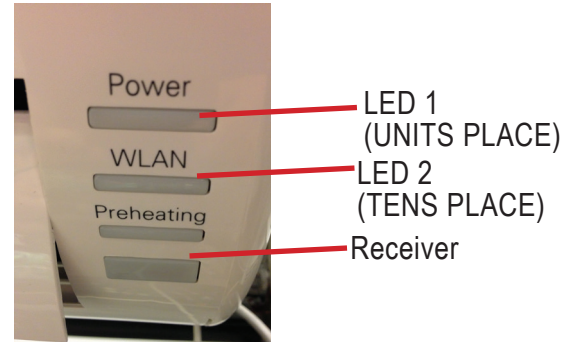

Figure 133: Example of Art Cool Mirror Wall-Mounted Indoor Unit LEDs.

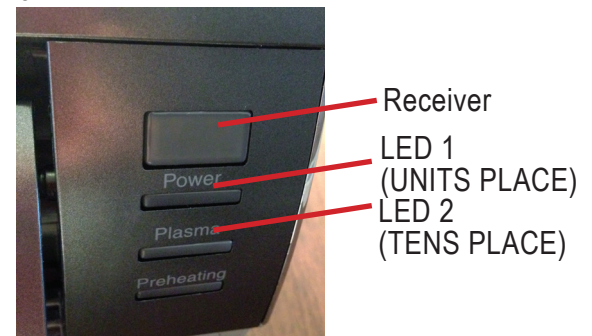
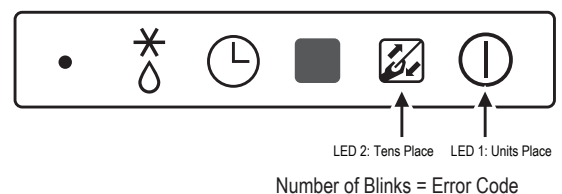

Figure 134: Example of Ceiling Cassette Indoor Unit LEDs.



### Note:

Appearances will vary depending on model.

Table 41: Indoor Unit Error Codes.

Error Code	Description	Indoor Unit Operation Status
00	No error	ON
01	Indoor unit room temperature sensor error	OFF
02	Indoor unit inlet pipe sensor error	OFF
03	Controller error	OFF
04	Drain pump error (optional)	OFF
05	Communication error between indoor unit and outdoor units	OFF
06	Indoor unit outlet pipe sensor error	OFF
07	Different mode operation error	OFF
09	Indoor unit EEPROM error	OFF
10	Indoor unit BLDC motor fan lock	OFF

# ERROR CODE TABLES

**⚠ WARNING** Please refer to the Safety Precautions on pages 4-7 for more detail to prevent injury or death regarding the operation and service troubleshooting of the Multi F / Multi F MAX with LGRED product.

Table 42: Outdoor Unit Error Codes.

Error Code	Description	No. of Times Outdoor Unit LEDs Blink		Outdoor Operation Status
		LED01 (Red)	LED02 (Green)	
21	DC Peak (IPM Fault); Compressor DC voltage was too high	2X	1X	OFF
22	Current Transformer2 (CT2) error; Alternating current (AC) input too high	2X	2X	OFF
23	DC Link Low Voltage (DC Link Voltage is <140VDC)	2X	3X	OFF
	DC Link High Voltage (DC Link Voltage is >420VDC)			
25	AC Low / High Voltage	2X	5X	OFF
26	DC Compressor Position Error (Compressor failed to start properly)	2X	6X	OFF
27	PSC / PFC Fault; Input current to inverter compressor PCB is too high	2X	7X	OFF
29	Current to inverter compressor is too high	2X	9X	OFF
32	Inverter compressor discharge pipe (D-Pipe) temperature is too high	3X	2X	OFF
35	Low Pressure Error; Pressure dropped below recommended limits	3X	5X	OFF
39	Communication Error between PFC MICOM and Inverter MICOM	3X	9X	OFF
40	CT Sensor Error; Thermistor is disconnected or has shorted out	4X	-	OFF
41	Inverter compressor discharge pipe (D-Pipe) sensor is disconnected or has shorted out	4X	1X	OFF
43	High pressure sensor is disconnected or has shorted out	4X	3X	OFF
44	Outdoor air sensor is disconnected or has shorted out	4X	4X	OFF
45	Mid-pipe thermistor of outdoor unit condenser is disconnected or has shorted out	4X	5X	OFF
46	Outdoor unit suction piping thermistor is disconnected or has shorted out	4X	6X	OFF
48	Outlet piping (liquid) of condenser is disconnected or has shorted out	4X	8X	OFF
51	Combination ratio (capacity) is out of range; Total nominal indoor unit capacity is <50% or >130% of the outdoor unit capacity	5X	1X	OFF
53	Communication failure between outdoor unit and indoor unit(s)	5X	3X	OFF
54	Outdoor unit is not wired properly (ex: reversed phase)	5X	4X	OFF
60	Outdoor unit printed circuit board (PCB) EEPROM check sum error	6X	-	OFF
61	Condenser coil thermistor temperature is too high	6X	1X	OFF
62	Outdoor unit inverter compressor PCB heat sink temperature is too high	6X	2X	OFF
65	Heat sink thermistor is disconnected or has shorted out	6X	5X	OFF
67	Outdoor unit brushless direct current (BLDC) fan motor lock error	6X	7X	OFF
73	Outdoor unit PFC overcurrent (peak) error	7X	3X	OFF

## LG Monitoring View (LGMV) Diagnostic Software

LG Monitoring View (LGMV) software allows the service technician or commissioning agent to connect a computer USB port to the Multi F / Multi F MAX with LGRED system's main printed circuit board (PCB) using an accessory cable without the need for a separate interface device.

LGMV is available in different formats, including Mobile LGMV, which is an app for use on wireless devices. Contact your LG Sales Representative for more information, including recommended PC or mobile device configurations.

Figure 135: LGMV Monitoring Screen.

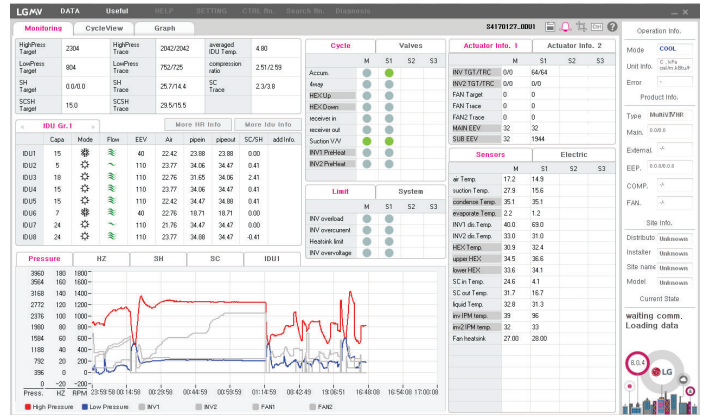

### Note:

- Images on these pages are examples of LGMV screenshots. Actual images will differ depending on the version of the software and the units installed.
- Information displayed also depends on which unit is installed.

### LGMV Display

LGMV displays the following real-time data:

- Actual inverter compressor speed
- Target inverter compressor speed
- Actual outdoor fan speed
- Target outdoor unit fan speed
- Actual superheat
- Target superheat
- Actual subcooler circuit superheat
- Target subcooler circuit superheat
- Main EEV position
- Subcooling EEV position
- Inverter compressor current transducer value
- Outdoor air temperature
- Actual high pressure/saturation temperature
- Actual low pressure/saturation temperature
- Suction temperature
- Inverter compressor discharge temperature
- Constant speed compressor discharge temperature
- Front outdoor coil pipe temperature
- Back outdoor coil pipe temperature
- Liquid line pipe temperature
- Subcooler inlet temperature
- Subcooler outlet temperature
- Average indoor unit (IDU) pipe temperature
- Inverter compressor operation indicator light
- Four-way reversing valve operation indicator light
- Pressure graph showing actual low pressure and actual high pressure levels
- Error code display
- Operating mode indicator
- Target high pressure
- Target low pressure
- PCB (printed circuit board) version
- Software version
- Installer name
- Model no. of outdoor units
- Site name
- Total number of connected indoor units
- Communication indicator lights
- Indoor unit capacity
- Indoor unit operating mode
- Indoor unit fan speed
- Indoor unit EEV position
- Indoor unit room temperature
- Indoor unit inlet pipe temperature
- Indoor unit outlet pipe temperature
- Indoor unit error code

# LG MONITORING VIEW (LGMV) DIAGNOSTIC SOFTWARE

MULTI F WITH LGRED<sup>®</sup>  
MULTI F MAX

Additional screens can be accessed by tabs on the main screen.  
Additional screens include:

1. Cycleview: Graphic of internal components including:

- Compressors showing actual speeds
- EEVs
- Indoor units
- Liquid injection valves
- Temperature and pressure sensors
- Four-way reversing valve
- Outdoor fans showing status and speeds

2. Graph: Full screen graph of actual high and low pressures and high and low pressure limits. A sliding bar allows viewing of previously recorded data.

3. Control IDU: Enables user to turn on IDU's default setpoints of 86°F in heat mode or 64°F in cool mode.

4. Setting: Converts metric values to imperial values.

5. Making Data: Recording of real time data to a separate file created to be stored on the user's computer.

6. Loading Data: Recorded data from a saved ".CSV" file can be loaded to create an LGMV session.

7. Electrical Data: The Electric tab on the main screen is changed to show the following:

- Inverter compressor
  - Amps
  - Volts
  - Power Hz
  - Inverter control board fan Hz
- Constant compressor
  - Current transducer value
  - Phase

**Note:**

- Images on these pages are examples of LGMV screenshots. Actual images will differ depending on the version of the software and the units installed.
- Information displayed also depends on which unit is installed.

Figure 137: LGMV Cycleview Screen.

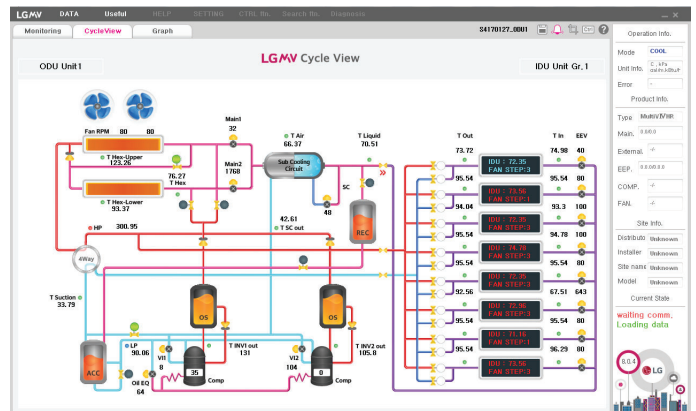
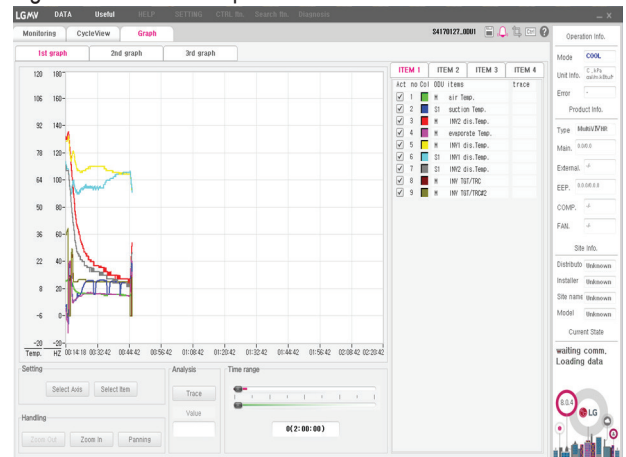

Figure 136: LGMV Graph Screen.



## LG SIMS

The LG Smart Inverter Monitoring System (SIMS) WLAN module and the smart phone app together provide monitoring and troubleshooting capability for LG Multi F / Multi F MAX with LGRED systems. SIMS functions only with LG Duct Free products, and can also be used with Single Zone one-to-one configurations such as the Single Zone Wall Mount systems.

SIMS can display and graph operational data for the air conditioner system including the indoor unit and the outdoor unit. SIMS also displays error codes and a troubleshooting guide. A full copy of the LG SIMS User's Manual is available on the [www.lghvac.com](http://www.lghvac.com) website.

To use SIMS you must be a trained HVAC service technician familiar with LG's Duct Free Systems. You must understand the inverter air conditioning operation cycle, the meaning of the data displayed by SIMS, and how to use the data to troubleshoot the system.

### Note:

- Images on these pages are examples of SIMS screenshots. Actual images will differ depending on the version of the software and the units installed.
- Information displayed also depends on which unit is installed.

### ⚠ WARNING

High voltages capable of causing death are used in this equipment. Outdoor unit power remains connected during this procedure. Take extreme caution not to touch electrical components or connections. Failure to observe this warning can result in death or severe injury.

### Note:

- The Duct Free System air conditioning system must run for at least 15–20 minutes before data collected by SIMS 2.0 is valid for troubleshooting.
- The free SIMS app must be correctly installed on a smart phone before using SIMS.
- Some outdoor units have an LGMV extension cable accessed by removing the side handle cover. If the outdoor unit does not have this extension cable, access the LGMV connector by removing the top cover of the outdoor unit.

### SIMs App Main Info Screen

The main screen is the first screen displayed after wireless connection is established. Tap the Main Info tab to display current readings regarding your indoor and outdoor unit(s). The Operational Info area of the screen will show active functions or modes by illuminating the light to the right of the function.

Additional Help information can be accessed by tapping the Help Menu buttons at the bottom of this screen.

Figure 138: LG SIMS App and WLAN Module.



Figure 139: Example of a SIMS WLAN Module Used with a Typical DFS System.

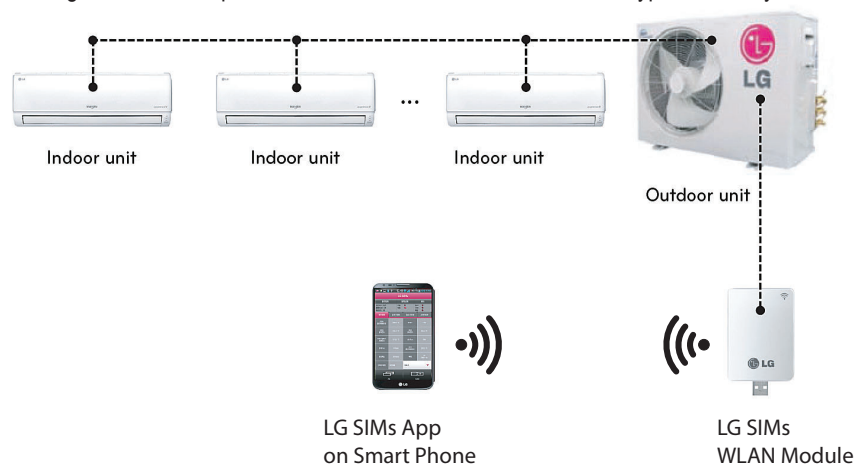

Figure 140: SIMs App Main Info Screen.

Main Info	Outdoor Info	Indoor Info	Graph Info
ODU Mid Temp	72.0 °F	Freq.	0 Hz
ODU Air Temp	72.0 °F	IDU Air Temp	72.0 °F
ODU Dis. Temp	72.0 °F	IDU FAN	Low
ODU FAN	0 Rpm	Pipe Mid	72.0 °F
EEV	460 Pulse	Error	00 (count : 0)
Max Limit	[0] None	IDU 1	



# LG SMART INVERTER MONITORING SYSTEM (SIMS)

MULTI F WITH LGRED°  
MULTI F MAX

## SIMS App Screens

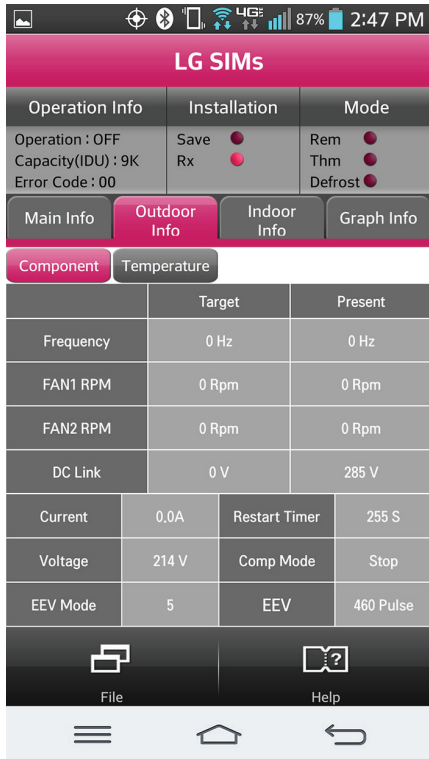

### Outdoor Info / Component Screen

Displays the following information:

- Frequency
- FAN1 RPM
- FAN2 RPM
- DC Link
- Current
- Voltage
- EEV Mode
- Restart Timer
- Comp Mode
- EEV

### Outdoor Info/ Temperature Screen

Displays the following information:

- Inv TD
- Suction
- Discharge
- Cond Mid
- Cond Out
- Heatsink
- Air Temp

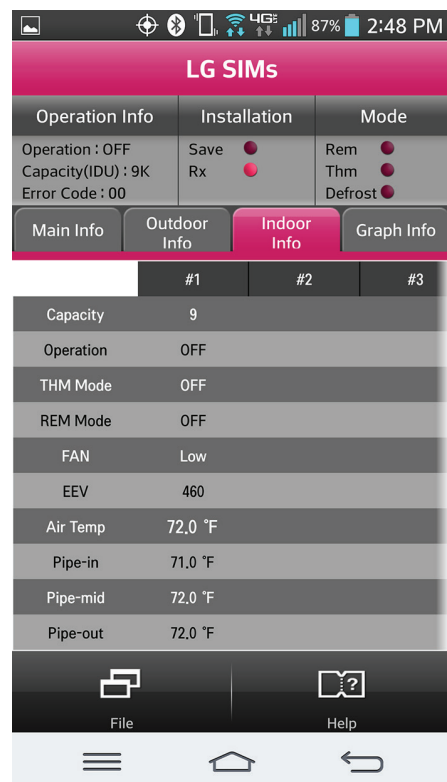
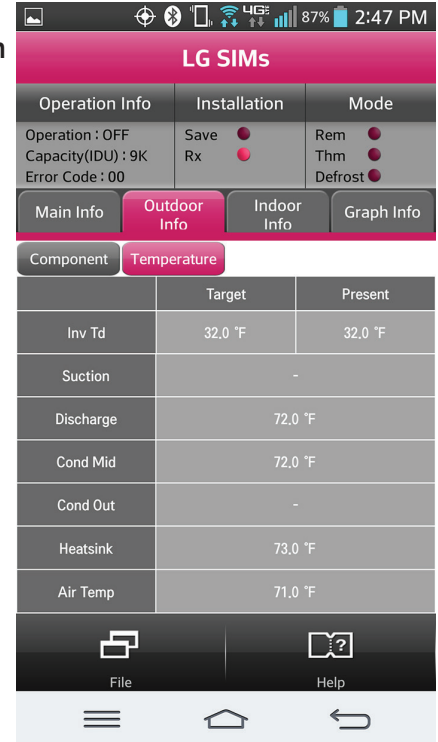

### Indoor Info Tab

Displays the following information:

- Frequency
- Operation
- THM Mode
- REM Mode
- FAN
- EEV
- Air Temp
- Pipe-in
- Pipe-mid
- Pipe-out

### Graph Info Tab

This tab, has three sub sections:

- IDU - Indoor Unit Temperature graph. Displays IDU information in graph format. Information displayed is for the IDU # selected on the Main screen.
- ODU - Outdoor Unit Temperature and Frequency graph. Displays ODU information in graph format.
- ODU Electric - Outdoor Unit Electric data graph is displayed.

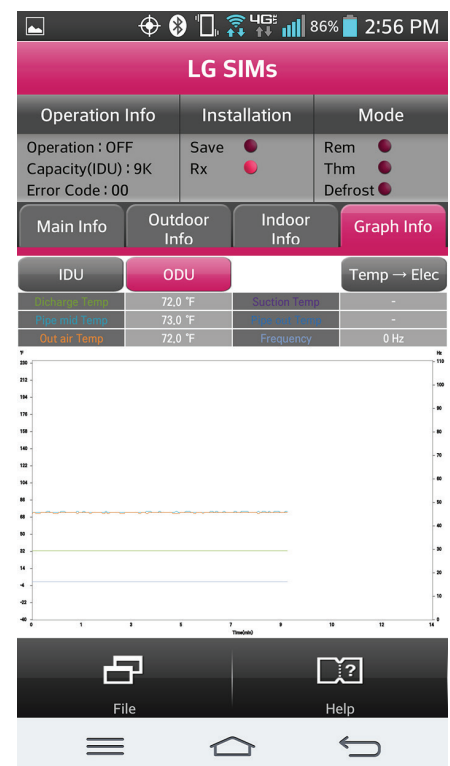

### Note:

- Images on these pages are examples of SIMS screenshots. Actual images will differ depending on the version of the software and the units installed.
- Information displayed also depends on which unit is installed.



Table 43: Maintenance Recommendations.

Component	Maintenance	Occurrence (Minimum)
Indoor Units	Wash filters	On a regular basis / as needed
	Clean coils	Once a year
	Clean / check unit base pan	Once a year
Outdoor Unit(s)	Clean coils	Once or twice a year
Communications Cable and Power Wiring	Verify that all cables and wiring are properly connected	Once or twice a year

**Note:**

*It is also recommended to monitor system operation using LGMV and / or SIMS Software at least once a year.*



# INSTALLATION CHECKLIST

PAGE 1

## Major Component Rough-In

Description	Check
Multi F / Multi F MAX with LGRED outdoor unit was connected properly per local code and the product installation procedures.	
All literature and bagged accessories have been removed from the fan discharge (ducted and cassette model indoor units).	
All indoor units and branch distribution unit(s) (Multi F MAX with LGRED only) are installed, properly supported, and located indoors in a non-corrosive environment.	
Duct work installation completed (ducted indoor units only).	

## Piping Material, Components, and Insulation

Description	Check
Multi-zone duct-free split systems: ACR copper piping rated at the system working pressure was used.	
LG Y-branch fitting was used per manufacturer's recommendations.	
All refrigerant pipes and valves were insulated separately. Insulation is positioned up against the walls of the indoor units and branch distribution units (Multi F MAX with LGRED only). No gaps shown. Insulation was not compressed at clamps and hangers.	

## Brazing Practices

Description	Check
Use medical grade dry nitrogen for purging during brazing (constant 3 psig while brazing).	
15% silver brazing material only.	

## Refrigerant Piping Design and System

Description	Check
You must have in your possession a copy of the "As-Designed" LATS Multi V piping tree diagram. BEFORE ANY FIELD PIPE SIZE OR LENGTH CHANGES ARE MADE, PROPOSED CHANGES MUST BE FORWARDED TO THE DESIGN ENGINEER SO THAT THEY CAN INPUT THE CHANGES INTO LATS and RE-ISSUE A NEW LATS MULTI V PIPING TREE DIAGRAM. Installer must receive change authorization from the design engineer, because any change made requires the review of the entire tree diagram and verification that the change did not impact the size of piping segments in other parts of the system.	
All pipe materials were properly stored, capped, and clean. All burrs were removed after cutting and pipe ends were reamed before brazing.	
During refrigerant pipe installation, for each segment of pipe, a record was made of the pipe length (including expansion loops, offsets, double-back sections), and sizes, as well as the quantity and type of elbows used.	
Expansion loops, coils or other acceptable measures are provided where necessary to absorb temperature-change based pipe movement.	
A torque wrench and backup wrench were used to tighten all flare connections.	
The back side of all flares were lubricated with a small drop of PVE refrigeration oil before tightening flare fittings.	
Ensure all field made flares are 45°. Use factory-supplied flare nuts only.	
Pipe segments and Y-branch fittings are secured to the structure using a combination of fixed and floating clamps, and all wall penetrations were sleeved.	
Pipe insulation was not compressed at any point.	
Y-branch fittings were properly INSTALLED per details provided in the Multi F / Multi F MAX with LGRED Outdoor Unit Installation Manual.	
Y-branch fittings were properly SUPPORTED per details provided in the Multi F / Multi F MAX with LGRED Outdoor Unit Installation Manual.	
No oil traps, solenoid valves, sight glasses, filter driers, or any other unauthorized refrigerant specialties were present.	
(Optional) High quality R-410A rated full port ball valves (Schrader between the valve body and the indoor units) used at all indoor units and at will in the refrigerant piping network.	



# INSTALLATION CHECKLIST

PAGE 2

## Condensate Pump / Drain Installation

Description	Check
Condensate piping installed correctly on indoor units. Material used is acceptable under local code. Insulated as necessary to prevent condensation.	
All condensate vertical risers are equal to or less than 27-1/2 inches from the bottom of the indoor unit.	
Indoor units with condensate pumps were level. Units with gravity drains were level or slightly canted toward the drain connection and are supported properly.	
Pumped condensate drain lines were properly connected (do not have traps, and connect to the top surface of the main drain line).	
Multi F / Multi F MAX with LGRED gravity condensate drain line was connected and routed where it properly drains away or, if installed in a mechanical room, was connected and properly routed to a drain terminal.	
All condensate lines were properly insulated to prevent condensation.	

## Power Wire and Communications Cables

Description	Check
Ground wire was installed and properly terminated at the unit.	
Power wiring was connected to a single phase 208-230V source.	
The power supplied was clean with voltage fluctuations within specifications ( $\pm 10\%$ of nameplate).	
Power wiring to the Multi F / Multi F MAX with LGRED outdoor unit was field supplied, solid or stranded, and installed per all local, state, and NEC requirements.	
<p>For Multi F with LGRED Systems</p> <ul style="list-style-type: none"> <li>• When the wiring length is up to 130 feet, communication / connection (power) wiring from the outdoor unit to the indoor unit is minimum 14 gauge, four-conductor, stranded, shielded or unshielded. If shielded, must be grounded to chassis at the outdoor unit only.</li> <li>• When the wiring length is GREATER THAN 130 feet, communication / connection (power) wiring from the outdoor unit to the indoor unit is minimum 14 gauge, stranded, shielded or unshielded. If shielded, must be grounded to chassis at the outdoor unit only. Use a two (2) conductor wire for power; use a two (2) conductor wire for communication / ground. Separate the power AT LEAST two (2) inches away from the communication / ground wire.</li> </ul>	
<p>For Multi F MAX with LGRED Systems</p> <p>All power wiring / communication cable to be minimum 14 AWG from the Multi F MAX with LGRED outdoor unit to the BD unit stranded, shielded or unshielded (if shielded, it must be grounded to the chassis of the outdoor unit only), and must comply with applicable local and national codes.</p> <ul style="list-style-type: none"> <li>• When the wiring length is up to 130 feet, communication / connection (power) wiring from the BD unit to the indoor unit is minimum 14 gauge, four-conductor, stranded, shielded or unshielded. If shielded, must be grounded to chassis at the outdoor unit only.</li> <li>• When the wiring length is GREATER THAN 130 feet, communication / connection (power) wiring from the BD unit to the indoor unit is minimum 14 gauge, stranded, shielded or unshielded. If shielded, must be grounded to chassis at the outdoor unit only. Use a two (2) conductor wire for power; use a two (2) conductor wire for communication / ground. Separate the power AT LEAST two (2) inches away from the communication / ground wire.</li> </ul>	
Power wiring to the outdoor unit and communication / connection (power) cable from the outdoor unit to the indoor units or branch distribution units (Multi F MAX with LGRED only) were separated per manufacturer's guidelines. These cannot be run in the same conduit.	
Communications / connection (power) cable were run in the same conduit (outdoor unit to indoor unit or branch distribution unit [Multi F MAX with LGRED only] as provided in the product installation manual.	
Proper communications cable was used between each indoor unit and its zone controller where applicable. No cables were spliced and no wire nuts are present.	
Communication type RS-485-BUS type.	
Used appropriate crimping tool to attach ring or fork terminals at all power wiring and control cable terminations.	
Only LG-supplied Y-cables were used between grouped indoor units, if applicable.	



# INSTALLATION CHECKLIST

PAGE 3

## Major Component Rough-In

## Piping and Insulation

## Brazing Practices



# INSTALLATION CHECKLIST

PAGE 4

## Installation—Refrigerant Piping

## Installation—Branch Distribution Unit (Multi F MAX with LGRED Systems Only)

## Installation—Condensate Pump / Drain Installation

## Installation—Power Wire and Communications Cables



# MULTI F WITH LGRED REFRIGERANT CHARGE WORKSHEET

LG Multi F with LGRED outdoor units ship from the factory with a charge of R410A refrigerant. A trim charge may need to be added to take into account additional piping length.

To determine the additional refrigerant that is needed, apply the formula below, and record the results. If the total additional refrigerant charge value is a negative number, then an additional trim charge does not need to be added to the system.

### Multi F with LGRED Outdoor Unit Factory Charge

Outdoor Unit	Factory Charge oz. of R410A
LMU180HHV	98.8
LMU240HHV	112.8
LMU300HHV	112.8

### Multi F with LGRED Outdoor Unit Additional Refrigerant Charge Formula

$$\begin{aligned} \text{Additional charge (lbs.)} &= (\text{Installed Length of Branch [A]} - \text{Chargeless Pipe Length [L]}) \times a \\ &+ (\text{Installed Length of Branch [B]} - \text{Chargeless Pipe Length [L]}) \times a \\ &+ (\text{Installed Length of Branch [C]} - \text{Chargeless Pipe Length [L]}) \times a \\ &+ (\text{Installed Length of Branch [D]} - \text{Chargeless Pipe Length [L]}) \times a \\ &- \text{CF (Correction Factor)} \times 5.29 \end{aligned}$$

### Note:

- Number of installed length of branches depends on the specifications of the outdoor unit model.
- CF = Maximum number of connectible indoor units – Total number of connected indoor units.

### Multi F with LGRED Outdoor Unit Piping Specifications

Multi F Outdoor Unit Model	Min. to Max. Piping Length for One Branch (ft.)	Max. Total System Piping Length (ft.)	Chargeless Pipe Length per Branch (L) (ft.)	Additional Charge Needed (a) (oz./ft.)
LMU180HHV	9.8 to 82	164	24.6	0.22
LMU240HHV	9.8 to 82	246.1	24.6	0.22
LMU300HHV	9.8 to 82	246.1	24.6	0.22

### Multi F with LGRED Refrigerant Charge Calculations

$$\begin{aligned} &(\text{_____ [A]} - 24.6) \times 0.22 && (\text{_____}) \\ + &(\text{_____ [B]} - 24.6) \times 0.22 && + (\text{_____}) \\ + &(\text{_____ [C]} - 24.6) \times 0.22 && + (\text{_____}) \\ + &(\text{_____ [D]} - 24.6) \times 0.22 && + (\text{_____}) \\ - &\text{_____ CF} \times 5.29 && - (\text{_____}) \\ = &\text{_____ Additional Charge (oz.)} \end{aligned}$$





# MULTI F MAX WITH LGRED REFRIGERANT CHARGE WORKSHEET

LG Multi F MAX with LGRED outdoor units ship from the factory with a charge of R410A refrigerant. A trim charge may need to be added to take into account additional piping length.

To determine the additional refrigerant that is needed, apply the formula below, and record the results. If the total additional refrigerant charge value is a negative number, then an additional trim charge does not need to be added to the system.

## Multi F MAX with LGRED Outdoor Unit Factory Charge

Outdoor Unit	Factory Charge oz. of R410A
LMU360HHV	197.5
LMU420HHV	197.5

$$\begin{aligned} \text{Additional charge (lbs.)} &= (\text{Total Main Piping Length [A]} - \text{Chargeless Pipe Length of Main Pipe [L]}) \times a \\ &+ (\text{Installed Length of Branch [B1]} - \text{Chargeless Pipe Length [B]}) \times b \\ &+ (\text{Installed Length of Branch [B2]} - \text{Chargeless Pipe Length [B]}) \times b \\ &+ (\text{Installed Length of Branch [B3]} - \text{Chargeless Pipe Length [B]}) \times b \dots \\ &- \text{CF (Correction Factor)} \times 3.53 \end{aligned}$$

### Note:

- Number of installed length of branches depends on system specifications.
- CF = Maximum number of connectible indoor units – Total number of connected indoor units

## Multi F MAX with LGRED Outdoor Unit Piping Specifications

Outdoor Unit Model	Main Piping Length		Branch Piping Length	
	Chargeless Pipe Length of Main Pipe (L) (ft.)	Additional Charge Needed (a) (oz./ft.)	Chargeless Pipe Length per Branch Pipe (B) (ft.)	Additional Charge Needed (b) (oz./ft.)
LMU360HHV	16.4	0.54	16.4	0.22
LMU420HHV	16.4	0.54	16.4	0.22

## Multi F MAX with LGRED Refrigerant Charge Calculations

$$\begin{aligned} &(\text{_____ [A]} - 16.4) \times 0.54 && (\text{_____}) \\ + &(\text{_____ [B1]} - 16.4) \times 0.22 && + (\text{_____}) \\ + &(\text{_____ [B2]} - 16.4) \times 0.22 && + (\text{_____}) \\ + &(\text{_____ [B3]} - 16.4) \times 0.22 && + (\text{_____}) \\ + &(\text{_____ [B4]} - 16.4) \times 0.22 && + (\text{_____}) \\ + &(\text{_____ [B5]} - 16.4) \times 0.22 && + (\text{_____}) \\ + &(\text{_____ [B6]} - 16.4) \times 0.22 && + (\text{_____}) \\ + &(\text{_____ [B7]} - 16.4) \times 0.22 && + (\text{_____}) \\ + &(\text{_____ [B8]} - 16.4) \times 0.22 && + (\text{_____}) \\ - &\text{_____ CF} \times 3.53 && - (\text{_____}) \end{aligned}$$

$$= \text{_____ Additional Charge (oz.)}$$

*Inverter*



LG Electronics, U.S.A., Inc.  
Air Conditioning Technologies  
4300 North Point Parkway  
Alpharetta, Georgia 30022  
www.lghvac.com

IM\_MultiF\_MAX\_LGRED\_ODU\_04\_20  
Supersedes: IM\_MultiF\_MAX\_LGRED\_ODU\_05\_18



# SINGLE ZONE HIGH EFFICIENCY, STANDARD, EXTENDED PIPE, AND MEGA WALL MOUNTED INSTALLATION MANUAL



Single Zone High Efficiency:

LS091HSV3, LS121HSV3, LS181HSV3, LS240HSV3

Single Zone Standard: LS307HV3, LS360HV3

Single Zone Extended Pipe: LS240HLV, LS300HLV, LS360HLV

Single Zone Mega: LS090HEV, LS120HEV, LS180HEV, LS240HEV;

LS090HEV1, LS120HEV1, LS180HEV1, LS240HEV1

Single Zone Mega 115V: LS090HXV, LS120HXV

## **PROPRIETARY DATA NOTICE**

This document, as well as all reports, illustrations, data, information, and other materials are the property of LG Electronics U.S.A., Inc., and are disclosed by LG Electronics U.S.A., Inc., only in confidence.

This document is for design purposes only.

**Do not throw away, destroy, or lose this manual.**

Please read carefully and store in a safe place for future reference.

Content familiarity required for proper installation.

The instructions included in this manual must be followed to prevent product malfunction, property damage, injury, or death to the user or other people. Incorrect operation due to ignoring any instructions will cause harm or damage. The level of seriousness is classified by the symbols described below.

A summary list of safety precautions begins on page 3.

IM\_WallMounted\_All\_11\_15

For more technical materials such as submittals, engineering databooks, and catalogs, visit [www.lghvac.com](http://www.lghvac.com).

For continual product development, LG Electronics U.S.A., Inc., reserves the right to change specifications without notice.





©LG Electronics U.S.A., Inc.

*This document, as well as all reports, illustrations, data, information, and other materials are the property of LG Electronics U.S.A., Inc.*

# SAFETY INSTRUCTIONS

The instructions below must be followed to prevent product malfunction, property damage, injury or death to the user or other people. Incorrect operation due to ignoring any instructions will cause harm or damage. The level of seriousness is classified by the symbols described below.

## TABLE OF SYMBOLS

 <b>DANGER</b>	<i>This symbol indicates an imminently hazardous situation which, if not avoided, will result in death or serious injury.</i>
 <b>WARNING</b>	<i>This symbol indicates a potentially hazardous situation which, if not avoided, could result in death or serious injury.</i>
 <b>CAUTION</b>	<i>This symbol indicates a potentially hazardous situation which, if not avoided, may result in minor or moderate injury.</i>
<b>Note</b>	<i>This symbol indicates situations that may result in equipment or property damage accidents only.</i>
	<i>This symbol indicates an action should not be completed.</i>

## INSTALLATION

### **DANGER**

 **Don't store or use flammable gas / combustibles near the unit.**

*There is risk of fire, explosion, and physical injury or death.*

### **WARNING**

 **Do not install, remove, or re-install the unit by yourself (end user). Ask the dealer or an authorized technician to install the unit.**

*Improper installation by the user may result in water leakage, fire, explosion, electric shock, physical injury or death.*

**For replacement of an installed unit, always contact an LG trained service provider.**

*There is risk of fire, electric shock, explosion, and physical injury or death.*

**The unit is shipped with refrigerant and the service valves closed.  Do not open service valves on the unit until all non-condensibles have been removed from the piping system and authorization to do so has been obtained from the commissioning agent.**

*There is a risk of physical injury or death.*

 **Do not run the compressor with the service valves closed.**

*There is a risk of explosion, physical injury, or death.*

**Periodically check that the outdoor frame is not damaged.**

*There is a risk of explosion, physical injury, or death.*

**Replace all control box and panel covers.**

*If cover panels are not installed securely, dust, water and animals may enter the unit, causing fire, electric shock, and physical injury or death.*

**Always check for system refrigerant leaks after the unit has been installed or serviced.**

*Exposure to high concentration levels of refrigerant gas may lead to illness or death.*

**Wear protective gloves when handling equipment. Sharp edges may cause personal injury.**

**Dispose the packing materials safely.**

• *Packing materials, such as nails and other metal or wooden parts, may cause puncture wounds or other injuries.*

• *Tear apart and throw away plastic packaging bags so that children may not play with them and risk suffocation and death.*

**Install the unit considering the potential for strong winds or earthquakes.**

*Improper installation may cause the unit to fall over, resulting in physical injury or death.*

 **Do not change the settings of the protection devices.**

*If the pressure switch, thermal switch, or other protection device is shorted and forced to operate improperly, or parts other than those specified by LG are used, there is risk of fire, electric shock, explosion, and physical injury or death.*

 **Do not install the unit on a defective stand.**

*There is a risk of physical injury.*

# SAFETY INSTRUCTIONS

## INSTALLATION - CONTINUED

### ⚠ WARNING

If the air conditioner is installed in a small space, take measures to prevent the refrigerant concentration from exceeding safety limits in the event of a refrigerant leak.

Consult the latest edition of ASHRAE (American Society of Heating, Refrigerating, and Air Conditioning Engineers) Standard 15. If the refrigerant leaks and safety limits are exceeded, it could result in personal injuries or death from oxygen depletion.

Install the unit in a safe location where nobody can step on or fall onto it.



*There is risk of physical injury or death.*

**Properly insulate all cold surfaces to prevent “sweating.”**

*Cold surfaces such as uninsulated piping can generate condensate that could drip, causing a slippery surface that creates a risk of slipping, falling, and personal injury.*

### ⚠ CAUTION

Be very careful when transporting the product.

-  Do not attempt to carry the product without assistance.
- Some products use polypropylene bands for packaging.  Do not use polypropylene bands to lift the unit.
- Suspend the unit from the base at specified positions.
- Support the unit a minimum of four points to avoid slippage from rigging apparatus.

#### Note:

 **Don't install the unit where it's directly exposed to ocean winds.**

*Ocean winds may cause corrosion, particularly on the condenser and evaporator fins, which, in turn could cause product malfunction or inefficient performance.*

**When installing the unit in a low-lying area, or a location that is not level, use a raised concrete pad or concrete blocks to provide a solid, level foundation.**

*This may prevent water damage and reduce abnormal vibration.*

**Properly insulate all cold surfaces to prevent “sweating.”**

*Cold surfaces such as uninsulated piping can generate condensate that may drip and cause a slippery surface condition and/or water damage to walls.*

**When installing the unit in a hospital, mechanical room, or similar electromagnetic field (EMF) sensitive environment, provide sufficient protection against electrical noise.**

*Inverter equipment, power generators, high-frequency medical equipment, or radio communication equipment may cause the air conditioner to operate improperly. The unit may also affect such equipment by creating electrical noise that disturbs medical treatment or image broadcasting.*

 **Do not use the product for special purposes such as preserving foods, works of art, wine coolers, or other precision air conditioning applications. The equipment is designed to provide comfort cooling and heating.**

*There is risk of property damage.*

 **Do not make refrigerant substitutions. Use R410A only.**

*If a different refrigerant is used, or air mixes with original refrigerant, the unit will malfunction and be damaged.*

**Keep the unit upright during installation to avoid vibration or water leakage.**

 **Do not install the unit in a noise sensitive area.**

**When connecting refrigerant tubing, remember to allow for pipe expansion.**

*Improper piping may cause refrigerant leaks and system malfunction.*

**Take appropriate actions at the end of HVAC equipment life to recover, recycle, reclaim or destroy R410A refrigerant according to applicable U.S. Environmental Protection Agency (EPA) rules.**

**Periodically check that the outdoor frame is not damaged.**

*There is a risk of equipment damage.*

**Install the unit in a safe location where nobody can step on or fall onto it.  Do not install the unit on a defective stand.**

*There is risk of unit and property damage.*

**Install the drain hose to ensure adequate drainage.**

*There is a risk of water leakage and property damage.*

 **Don't store or use flammable gas / combustibles near the unit.**

*There is risk of product failure.*

**Always check for system refrigerant leaks after the unit has been installed or serviced.**

*Low refrigerant levels may cause product failure*

**The unit is shipped with refrigerant and the service valves closed.  Do not open service valves on the unit until all non-condensibles have been removed from the piping system and authorization to do so has been obtained from the commissioning agent.**

*There is a risk of refrigerant contamination, refrigerant loss and equipment damage.*

 **Do not run the compressor with the service valves closed.**

*There is a risk of equipment damage.*



# SAFETY INSTRUCTIONS

---

---

## WIRING

### **⚠ DANGER**

**High voltage electricity is required to operate this system. Adhere to the National Electrical Codes and these instructions when wiring.**

*Improper connections and inadequate grounding can cause accidental injury or death.*

**Always ground the unit following local, state, and National Electrical Codes.**

**Turn the power off at the nearest disconnect before servicing the equipment.**

*Electrical shock can cause physical injury or death.*

**Properly size all circuit breakers or fuses.**

*There is risk of fire, electric shock, explosion, physical injury or death.*

### **⚠ WARNING**

**The information contained in this manual is intended for use by an industry-qualified, experienced, certified electrician familiar with the U.S. National Electric Code (NEC) who is equipped with the proper tools and test instruments.**

*Failure to carefully read and follow all instructions in this manual can result in equipment malfunction, property damage, personal injury or death.*

**All electric work must be performed by a licensed electrician and conform to local building codes or, in the absence of local codes, with the National Electrical Code, and the instructions given in this manual.**

*If the power source capacity is inadequate or the electric work is not performed properly, it may result in fire, electric shock, physical injury or death.*

**Refer to local, state, and federal codes, and use power wires of sufficient current capacity and rating.**

*Wires that are too small may generate heat and cause a fire.*

**Secure all field wiring connections with appropriate wire strain relief.**

*Improperly securing wires will create undue stress on equipment power lugs. Inadequate connections may generate heat, cause a fire and physical injury or death.*

# SAFETY INSTRUCTIONS

## OPERATION

### **⚠ DANGER**

- ⊘ Do not provide power to or operate the unit if it is flooded or submerged.

*There is risk of fire, electric shock, physical injury or death.*

**Use a dedicated power source for this product.**

*There is risk of fire, electric shock, physical injury or death.*

### **⚠ WARNING**

- ⊘ Do not allow water, dirt, or animals to enter the unit.

*There is risk of fire, electric shock, physical injury or death.*

**Avoid excessive cooling and periodically perform ventilation to the unit.**

*Inadequate ventilation is a health hazard.*

- ⊘ Do not touch the refrigerant piping during or after operation.

*It can cause burns or frostbite.*

- ⊘ Do not operate the unit with the panel(s) or protective cover(s) removed; keep fingers and clothing away from moving parts.

*The rotating, hot, cold, and high-voltage parts of the unit can cause physical injury or death.*

**Periodically verify the equipment mounts have not deteriorated.**

*If the base collapses, the unit could fall and cause physical injury or death.*

### **⚠ CAUTION**

**To avoid physical injury, use caution when cleaning or servicing the air conditioner.**

#### **Note:**

**Clean up the site after installation is finished, and check that no metal scraps, screws, or bits of wiring have been left inside or surrounding the unit.**

- ⊘ Do not use this equipment in mission critical or special-purpose applications such as preserving foods, works of art, wine coolers or refrigeration. The equipment is designed to provide comfort cooling and heating.

*Oil, steam, sulfuric smoke, etc., can significantly reduce the performance of the unit, or damage its parts.*

**Provide power to the compressor crankcase heaters at least six (6) hours before operation begins.**

*Starting operation with a cold compressor sump(s) may result in severe bearing damage to the compressor(s). Keep the power switch on during the operational season.*

- ⊘ Do not operate the disconnect switch with wet hands.

*There is risk of fire, electric shock, physical injury or death.*

**If gas leaks out, ventilate the area before operating the unit.**

*If the unit is mounted in an enclosed, low-lying, or poorly ventilated area, and the system develops a refrigerant leak, it may cause fire electric shock, explosion, physical injury or death.*

**Periodically, check power cord and plug for damage.**

*Cord must be replaced by the manufacturer, its service agent, or similar qualified persons in order to avoid physical injury and/or electric shock.*

- ⊘ Do not open the inlet grille of the unit during operation.

- ⊘ Do not operate the unit with the panels or guards removed. ⊘ Do not insert hands or other objects through the inlet or outlet when the unit is plugged in. ⊘ Do not touch the electrostatic filter, if the unit includes one.

*The unit contains sharp, rotating, hot, and high voltage parts that can cause personal injury and/or electric shock.*

**Securely attach the electrical part cover to the indoor unit and the service panel to the outdoor unit.**

*Non-secured covers can result in burns or electric shock due to dust or water in the service panel.*

- ⊘ Do not block the inlet or outlet.

*Unit may malfunction.*

**Securely attach the electrical part cover to the indoor unit and the service panel to the outdoor unit.**

*Non-secured covers can result in malfunction due to dust or water in the service panel.*

**Periodically verify the equipment mounts have not deteriorated.**

*If the base collapses, the unit could fall and cause property damage or product failure.*

- ⊘ Do not allow water, dirt, or animals to enter the unit.

*There is risk of unit failure.*

# TABLE OF CONTENTS

Safety Instructions .....	3	Refrigerant Piping Connections.....	36
General Data .....	8	<i>Refrigerant Piping System Limitations</i> .....	36
<i>Unit Nomenclature</i> .....	8	<i>Installation Overview</i> .....	38
<i>Single Zone High Efficiency Unit Specifications</i> .....	9	<i>Directional Pipe Formation</i> .....	39
<i>Single Zone Standard Unit Specifications</i> .....	10	<i>Drain Hose</i> .....	40
<i>Single Zone Extended Pipe Unit Specifications</i> .....	11	<i>Outdoor Unit Connections</i> .....	41-42
<i>Single Zone Mega Unit Specifications</i> .....	12-13	<i>Indoor Unit Connections</i> .....	43
<i>Single Zone Mega 115V Unit Specifications</i> .....	14	<i>Indoor Unit Connections - Conduit Bracket Placement</i> .....	44
<i>Electrical</i> .....	15	<i>Bundling and Cutting Line</i> .....	45
<i>R410A Refrigerant</i> .....	16	<i>Refrigerant Piping Insulation</i> .....	46-48
General Installation Guidelines.....	17	<i>Air Purging</i> .....	49
<i>Location Selection</i> .....	17	<i>Leak Test/Soap Method Check</i> .....	50
<i>Oceanside Applications</i> .....	18	<i>Evacuation of Lines</i> .....	51
<i>Mounting Bolt Location</i> .....	19	<i>Finishing Up</i> .....	51
<i>Required Clearances</i> .....	19-20	<i>Remote Controller</i> .....	51
<i>Mounting of Indoor Unit Installation Plate</i> .....	21-25	<i>Pump Down, Cooling Only Mode</i> .....	52
<i>Mounting of Indoor Unit</i> .....	26	Electrical Wiring .....	53
<i>Piping Preparation</i> .....	27	<i>General Information and Safety Guidelines</i> .....	53
<i>Piping Materials and Handling</i> .....	28-33	<i>Power Wiring Specifications and Best Practices</i> .....	53-55
<i>Piping Support, Elbow Usage</i> .....	33	<i>Controllers</i> .....	55
<i>Refrigerant Piping System Layout</i> .....	35	<i>Indoor Unit Electrical Connections</i> .....	56-60
		<i>Outdoor Unit Electrical Connections</i> .....	61-65
		<i>Self Diagnosis Functions</i> .....	66-67
		<i>LG SIMS - Self Diagnosis Functions</i> .....	68-69
		Troubleshooting .....	70
		<i>Error Codes</i> .....	70-72
		<i>Refrigerant Leaks</i> .....	73
		Installation Checklist.....	74

# GENERAL DATA

## Unit Nomenclature

### Single Zone Wall Mount Indoor and Outdoor Units

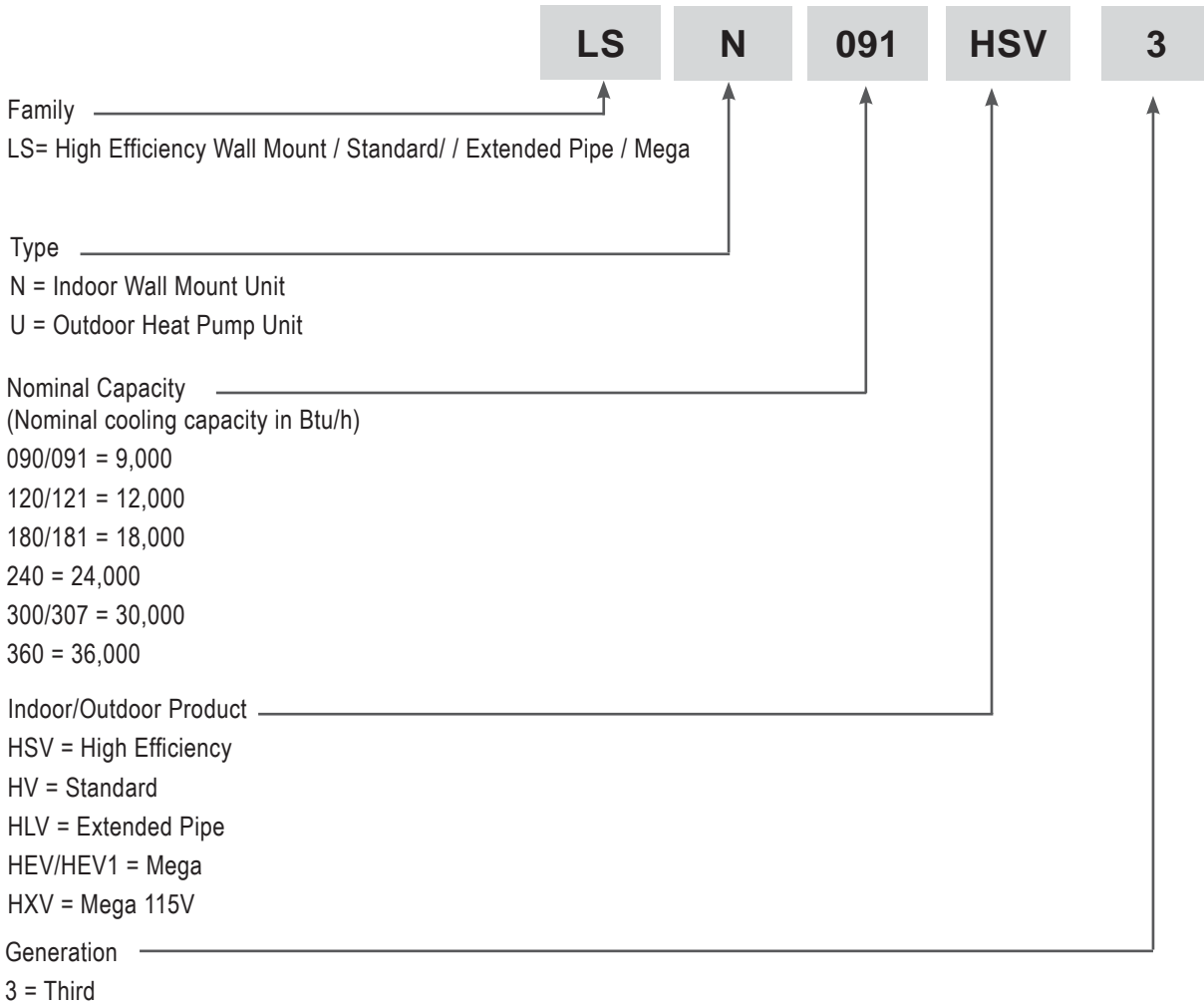

# GENERAL DATA

## Single Zone High Efficiency Unit Specifications

Table 1: Single Zone High Efficiency Unit Specifications

Type	Single Zone High Efficiency Units			
System Model Number (IDU/ODU)	LS091HSV3 (LSN091HSV3/ LSU091HSV3)	LS121HSV3 (LSN121HSV3/ LSU121HSV3)	LS181HSV3 (LSN181HSV3/ LSU181HSV3)	LS240HSV3 (LSN240HSV3/ LSU240HSV3)
Nominal Cooling Capacity (Btu/h)	9,000	11,200	18,200	22,000
Cooling Power Input <sup>1</sup> (kW)	0.67	0.89	1.4	1.7
Nominal Heating Capacity (Btu/h) <sup>1</sup>	10,800	13,300	22,000	27,600
Heating Power Input <sup>1</sup> (kW)	0.70	1.0	1.7	2.3
COP	4.53	3.90	3.66	3.4
EER	13.3	12.5	12.6	12.5
SEER	21.5	21.5	20.5	20.0
HSPF	11.0	11.0	9.7	10.2
Power Supply (V/Hz/Ø)	208-230/60/1			
<b>Outdoor Unit Operating Range<sup>2</sup></b>				
Cooling (°F DB)	14-118			
Heating (°F WB)	-4-75			
<b>Indoor Unit Operating Range<sup>2</sup></b>				
Cooling (°F)	64-90			
Heating (°F)	60-86			
<b>Unit Data</b>				
Refrigerant Type <sup>3</sup>	R410A			
Refrigerant Control	EEV			
IDU Sound Pressure <sup>4</sup> dB(A) (H/M/L)	38/33/24	39/33/24	45/40/35	46/43/39
ODU Sound Pressure <sup>4</sup> dB(A)	45	45	53	54
Power/Communication Cable <sup>5</sup> (No. x AWG)	4 x 18			
IDU Net/Shipping Weight (lbs)	23/28	23/28	32/41	36/42
ODU Net/Shipping Weight (lbs)	75/79	75/79	123/131	128/137
<b>Compressor</b>				
Compressor Type (Qty)	Rotary (1)	Rotary (1)	Twin Rotary (1)	Twin Rotary (1)
<b>Fan</b>				
IDU Type (Qty)	Cross Flow (1)			
ODU Type (Qty)	Propeller (1)			
Motor/Drive	Brushless Digitally Controlled/Direct			
<b>Airflow Rate</b>				
IDU Max/H/M/L (CFM)	388/335/272/212	423/353/272/212	735/622/509/399	883/742/629/424
ODU Max (CFM)	1,165	1,165	2,119	2,119
<b>Piping</b>				
Liquid Line (in, OD)	1/4	1/4	3/8	3/8
Vapor Line (in, OD)	3/8	3/8	5/8	5/8
Condensation Line (OD, ID)	27/32, 5/8	27/32, 5/8	27/32, 5/8	27/32, 5/8
Additional Refrigerant Charge (oz/ft)	0.22	0.22	0.38	0.38
Pipe Length <sup>6</sup> (ft) (Min./Max.)	6.6/65.6	6.6/65.6	9.8/98.4	9.8/98.4
Piping Length <sup>6</sup> (no add'l refrigerant, ft)	41.0	41.0	24.6	24.6
Max Elevation Difference (ft)	32.8	32.8	49.2	49.2

EEV: Electronic Expansion Valve IDU: Indoor Unit ODU: Outdoor Unit

<sup>1</sup>Power Input is rated at high speed.

<sup>2</sup>Low Ambient Wind Baffle Kit allows operation down to 0°F in cooling mode.

<sup>3</sup>Take appropriate actions at the end of HVAC equipment life to recover, recycle, reclaim or destroy R410A refrigerant according to applicable regulations (40 CFR Part 82, Subpart F) under section 608 of CAA.

<sup>4</sup>Sound Pressure levels are tested in an anechoic chamber under ISO Standard 1996.

<sup>5</sup>Power/communication cables from the outdoor unit to the indoor unit to be minimum 18 AWG, 4-conductor, stranded, shielded or unshielded (if shielded, it must be grounded to the chassis at the outdoor unit only) and must comply with applicable and national code.

<sup>6</sup>Piping lengths are equivalent.

Power wiring to the outdoor unit is field supplied, solid or stranded, and must comply with the applicable local and national codes.

This unit comes with a dry helium charge.

This data is rated 0 ft above sea level with 24.6 of refrigerant line per indoor unit and a 0 ft level difference outdoor and indoor units.

Cooling capacity rating obtained with air entering the indoor unit at 80°F dry bulb (DB) and 67°F wet bulb (WB) and outdoor ambient conditions of 95°F dry bulb (DB) and 75°F wet bulb (WB).

Heating capacity rating obtained with air entering the indoor unit at 70°F dry bulb (DB) and 59°F wet bulb (WB) and outdoor ambient conditions of 47°F dry bulb (DB) and 43°F wet bulb (WB).



# GENERAL DATA

## Single Zone Standard Unit Specifications

Table 2: Single Zone Standard Unit Specifications

Type System Model Number (IDU/ODU)	Single Zone Standard Units	
	LS307HV3 (LSN307HV3/LSU307HV3)	LS360HV3 (LSN360HV3/LSU360HV3)
Nominal Cooling Capacity (Btu/h)	30,000	33,000
Cooling Power Input <sup>1</sup> (kW)	3.0	4.0
Nominal Heating Capacity (Btu/h) <sup>1</sup>	32,000	35,200
Heating Power Input <sup>1</sup> (kW)	3.1	3.8
COP	3.0	2.7
EER	10.0	8.2
SEER	18.0	16.1
HSPF	9.5	9.9
Power Supply (V/Hz/Ø)	208-230/60/1	208-230/60/1
<b>Outdoor Unit Operating Range</b>		
Cooling (°F DB)	14-118	14-118
Heating (°F WB)	-4-75	-4-75
<b>Indoor Unit Operating Range</b>		
Cooling (°F)	64-90	64-90
Heating (°F)	60-86	60-86
<b>Unit Data</b>		
Refrigerant Type <sup>2</sup>	R410A	R410A
Refrigerant Control	EEV	EEV
IDU Sound Pressure <sup>3</sup> dB(A) (H/M/L)	49/44/39	49/44/39
ODU Sound Pressure <sup>3</sup> dB(A)	55	55
Power/Communication Cable <sup>4</sup> (No. x AWG)	4 x 18	4 x 18
IDU Net/Shipping Weight (lbs)	36/42	36/42
ODU Net/Shipping Weight (lbs)	128/137	128/137
<b>Compressor</b>		
Compressor Type (Qty)	Twin Rotary (1)	Twin Rotary (1)
<b>Fan</b>		
IDU Type (Qty)	Cross Flow	Cross Flow
ODU Type (Qty)	Propeller	Propeller
Motor/Drive	Brushless Digitally Controlled/Direct	
<b>Airflow Rate</b>		
IDU Max/H/M/L (CFM)	883/770/629/424	883/795/629/424
ODU Max (CFM)	2,119	2,119
<b>Piping</b>		
Liquid Line (in, OD)	3/8	3/8
Vapor Line (in, OD)	5/8	5/8
Condensation Line (OD/ID)	27/32, 5/8	27/32, 5/8
Additional Refrigerant Charge (oz/ft)	0.38	0.38
Pipe Length <sup>5</sup> (ft) (Min./Max.)	9.8/98.4	9.8/98.4
Piping Length <sup>5</sup> (no add'l refrigerant, ft)	24.6	24.6
Max Elevation Difference (ft)	49.2	49.2

EEV: Electronic Expansion Valve IDU: Indoor Unit ODU: Outdoor Unit

<sup>1</sup>Power Input is rated at high speed.

<sup>2</sup>Take appropriate actions at the end of HVAC equipment life to recover, recycle, reclaim or destroy R410A refrigerant according to applicable regulations (40 CFR Part 82, Subpart F) under section 608 of CAA.

<sup>3</sup>Sound Pressure levels are tested in an anechoic chamber under ISO Standard 1996.

<sup>4</sup>Power/communication cables from the outdoor unit to the indoor unit to be minimum 18 AWG, 4-conductor, stranded, shielded or unshielded (if shielded, it must be grounded to the chassis at the outdoor unit only) and must comply with applicable and national code.

<sup>5</sup>Piping lengths are equivalent.

Power wiring to the outdoor unit is field supplied, solid or stranded, and must comply with the applicable local and national codes.

This unit comes with a dry helium charge.

This data is rated 0 ft above sea level with 24.6 of refrigerant line per indoor unit and a 0 ft level difference outdoor and indoor units.

Cooling capacity rating obtained with air entering the indoor unit at 80°F dry bulb (DB) and 67°F wet bulb (WB) and outdoor ambient conditions of 95°F dry bulb (DB) and 75°F wet bulb (WB).

Heating capacity rating obtained with air entering the indoor unit at 70°F dry bulb (DB) and 59°F wet bulb (WB) and outdoor ambient conditions of 47°F dry bulb (DB) and 43°F wet bulb (WB).



# GENERAL DATA

## Single Zone Extended Pipe Unit Specifications

Table 3: Single Zone Extended Pipe Unit Specifications

Type	Single Zone Extended Pipe Units		
System Model Number (IDU/ODU)	LS240HLV (LSN240HLV/LSU240HLV)	LS300HLV (LSN300HLV/LSU300HLV)	LS360HLV (LSN360HLV/LSU360HLV)
Nominal Cooling Capacity (Btu/h)	22,000	30,000	33,000
Cooling Power Input <sup>1</sup> (kW)	1.7	3.0	4.0
Nominal Heating Capacity (Btu/h) <sup>1</sup>	27,000	32,000	35,200
Heating Power Input <sup>1</sup> (kW)	2.3	3.1	3.8
COP	3.32	3.03	2.69
EER	12.5	10.0	8.2
SEER	21.0	18.5	16.5
HSPF	11	10	10
Power Supply (V/Hz/Ø)	208-230/60/1		
<b>Outdoor Unit Operating Range</b>			
Cooling (°F DB)	14-118		
Heating (°F WB)	-4-65		
<b>Indoor Unit Operating Range</b>			
Cooling (°F)	53-75		
Heating (°F)	60-86		
<b>Unit Data</b>			
Refrigerant Type <sup>2</sup>	R410A		
Refrigerant Control	EEV		
IDU Sound Pressure <sup>3</sup> dB(A) (H/M/L)	49/44/40	49/44/40	49/44/40
ODU Sound Pressure <sup>3</sup> dB(A)	55	55	55
Power/Communication Cable <sup>4</sup> (No. x AWG)	4 x 18		
IDU Net/Shipping Weight (lbs)	40/46	40/46	40/46
ODU Net/Shipping Weight (lbs)	125/133	125/133	125/133
<b>Compressor</b>			
Compressor Type (Qty)	Twin Rotary (1)	Twin Rotary (1)	Twin Rotary (1)
<b>Fan</b>			
IDU Type (Qty)	Cross Flow		
ODU Type (Qty)	Propeller		
Motor/Drive	Brushless Digitally Controlled/Direct		
<b>Airflow Rate</b>			
IDU Max/H/M/L (CFM)	848/706/530/459	848/706/530/459	848/706/530/459
ODU Max (CFM)	2,119	2,119	2,119
<b>Piping</b>			
Liquid Line (in, OD)	3/8	3/8	3/8
Vapor Line (in, OD)	5/8	5/8	5/8
Condensation Line (OD, ID)	27/32, 5/8	27/32, 5/8	27/32, 5/8
Additional Refrigerant Charge (oz/ft)	0.38	0.38	0.38
Pipe Length <sup>5</sup> (ft) (Min./Max.)	9.8/164	9.8/164	9.8/164
Piping Length <sup>5</sup> (no add'l refrigerant, ft)	24.6	24.6	24.6
Max Elevation Difference (ft)	98.4	98.4	98.4

EEV: Electronic Expansion Valve IDU: Indoor Unit ODU: Outdoor Unit

<sup>1</sup>Power Input is rated at high speed.

<sup>2</sup>Take appropriate actions at the end of HVAC equipment life to recover, recycle, reclaim or destroy R410A refrigerant according to applicable regulations (40 CFR Part 82, Subpart F) under section 608 of CAA.

<sup>3</sup>Sound Pressure levels are tested in an anechoic chamber under ISO Standard 1996.

<sup>4</sup>Power/communication cables from the outdoor unit to the indoor unit to be minimum 18 AWG, 4-conductor, stranded, shielded or unshielded (if shielded, it must be grounded to the chassis at the outdoor unit only) and must comply with applicable and national code.

<sup>5</sup>Piping lengths are equivalent.

Power wiring to the outdoor unit is field supplied, solid or stranded, and must comply with the applicable local and national codes.

This unit comes with a dry helium charge.

This data is rated 0 ft above sea level with 24.6 of refrigerant line per indoor unit and a 0 ft level difference outdoor and indoor units.

Cooling capacity rating obtained with air entering the indoor unit at 80°F dry bulb (DB) and 67°F wet bulb (WB) and outdoor ambient conditions of 95°F dry bulb (DB) and 75°F wet bulb (WB). Heating capacity rating obtained with air entering the indoor unit at 70°F dry bulb (DB) and 59°F wet bulb (WB) and outdoor ambient conditions of 47°F dry bulb (DB) and 43°F wet bulb (WB).

# GENERAL DATA

## Single Zone Mega Unit (HEV) Specifications

Table 4: Single Zone Mega Unit (HEV) Specifications

Type System (Model IDU/ODU)	Single Zone Mega (HEV) Inverter			
	LS090HEV (LSN090HEV/ LSU090HEV)	LS120HEV (LSN120HEV/ LSU120HEV)	LS180HEV (LSN180HEV/ LSU180HEV)	LS240HEV (LSN240HEV/ LSU240HEV)
Nominal Cooling Capacity (Btu/h)	8,500	12,000	17,000	22,000
Cooling Power Input <sup>1</sup> (kW)	0.78	1.17	1.55	2.04
Nominal Heating Capacity (Btu/h)	9,000	12,000	19,000	22,000
Heating Power Input <sup>1</sup> (kW)	0.78	0.98	1.59	1.93
COP	3.19	3.00	3.19	3.00
EER	10.90	10.26	10.95	10.75
SEER	16.3	16.3	17.0	17.0
HSPF	8.3	8.5	8.7	8.5
Power Supply (V / Hz / Ø)	208-230/60/1			
<i>ODU Operating Range</i>				
Cooling (°F DB)	64-118			
Heating (°F WB)	23-75			
<i>IDU Operating Range</i>				
Cooling (°F WB)	64-90			
Heating (°F DB)	60-86			
<i>Indoor Temperature Setting Range</i>				
Cooling (°F)	65-86			
Heating (°F)	61-86			
<i>Unit Data</i>				
Refrigerant Type <sup>2</sup>	R410A			
Refrigerant Control	Capillary Tube			
IDU Sound Pressure <sup>3</sup> ± 3 dB(A) (H/M/L)	39/33/25	39/33/25	42/40/35	45/40/35
ODU Sound Pressure ± 3 dB(A)	47	47	51	53
Indoor Unit (Net/Shipping Weight lbs.)	16/21	20/25	28/30	28/34
Outdoor Unit (Net/Shipping Weight lbs.)	52/56	49/53	72/77	92/104
Power/Communication Cable <sup>4</sup> (No. x AWG)	4 x 18			
<i>Compressor</i>				
Compressor Type (Qty)	Single Rotary (1)	Single Rotary (1)	Twin Rotary (1)	Twin Rotary (1)
<i>Fan</i>				
Indoor Type (Qty)	Cross Flow (1)			
Outdoor Type (Qty)	Propeller (1)			
Motor/Drive	Brushless Digitally Controlled/Direct			
<i>Airflow Rate</i>				
Indoor - Max/H/M/L (CFM)	318/276/226/177	424/353/272/212	629/512/441/353	689/600/494/388
Outdoor - Max (CFM)	953	953	1,342	1,766
<i>Piping</i>				
Liquid Line (in, OD)	1/4	1/4	1/4	1/4
Vapor Line (in, OD)	3/8	3/8	1/2	5/8
Condensation Line (OD   ID)	27/32   5/8	27/32   5/8	27/32   5/8	27/32   5/8
Additional Refrigerant Charge (oz/ft)	0.22	0.22	0.33	0.33
Pipe Length <sup>5</sup> (ft) (Min./Max.)	9.8/49.2	9.8/49.2	9.8/65.6	9.8/65.6
Piping Length (no add'l refrigerant, ft) <sup>5</sup>	24.6	24.6	24.6	24.6
Max Elevation Difference (ft)	22.9	22.9	32.8	32.8

EEV: Electronic Expansion Valve IDU: Indoor Unit ODU: Outdoor Unit

<sup>1</sup>Power Input is rated at high speed.

<sup>2</sup>Take appropriate actions at the end of HVAC equipment life to recover, recycle, reclaim or destroy R410A refrigerant according to applicable regulations (40 CFR Part 82, Subpart F) under section 608 of CAA.

<sup>3</sup>Sound Pressure levels are tested in an anechoic chamber under ISO Standard 1996.

<sup>4</sup>Power/communication cables from the outdoor unit to the indoor unit to be minimum 18 AWG, 4-conductor, stranded, shielded or unshielded (if shielded, it must be grounded to the chassis at the outdoor unit only) and must comply with applicable and national code.

<sup>5</sup>Piping lengths are equivalent.

Power wiring to the outdoor unit is field supplied, solid or stranded, and must comply with the applicable local and national codes. This unit comes with a dry helium charge.

This data is rated 0 ft above sea level with 24.6 of refrigerant line per indoor unit and a 0 ft level difference outdoor and indoor units.

Cooling capacity rating obtained with air entering the indoor unit at 80°F dry bulb (DB) and 67°F wet bulb (WB) and outdoor ambient conditions of 95°F dry bulb (DB) and 75°F wet bulb (WB).

Heating capacity rating obtained with air entering the indoor unit at 70°F dry bulb (DB) and 59°F wet bulb (WB) and outdoor ambient conditions of 47°F dry bulb (DB) and 43°F wet bulb (WB).

# GENERAL DATA

## Single Zone Mega Unit (HEV1) Specifications

Table 5: Single Zone Mega Unit (HEV1) Specifications

Type System (Model IDU/ODU)	Single Zone Mega (HEV1) Inverter			
	LS090HEV1 (LSN090HEV1/ LSU090HEV1)	LS120HEV1 (LSN120HEV1/ LSU120HEV1)	LS180HEV1 (LSN180HEV1/ LSU180HEV1)	LS240HEV1 (LSN240HEV1/ LSU240HEV1)
Nominal Cooling Capacity (Btu/h)	8,500	12,000	17,000	22,000
Cooling Power Input <sup>1</sup> (kW)	0.68	1.14	1.55	2.045
Nominal Heating Capacity (Btu/h)	9,000	12,000	19,000	22,000
Heating Power Input <sup>1</sup> (kW)	0.78	0.98	1.59	1.935
COP	11.54	12.24	11.95	11.37
EER	12.5	10.52	10.97	10.76
SEER	19.0	17.0	18.0	17.0
HSPF	9.0	9.2	9.0	9.0
Power Supply (V / Hz / Ø)	208-230/60/1			
<i>ODU Operating Range</i>				
Cooling (°F DB)	14-118			
Heating (°F WB)	14-65			
<i>IDU Operating Range</i>				
Cooling (°F WB)	53-75			
Heating (°F DB)	60-86			
<i>Indoor Temperature Setting Range</i>				
Cooling (°F)	64-86			
Heating (°F)	60-86			
<i>Unit Data</i>				
Refrigerant Type <sup>2</sup>	R410A			
Refrigerant Control	EEV			
IDU Sound Pressure <sup>3</sup> ± 3 dB(A) (H/M/L)	39/33/25/19	39/33/25/19	42/40/35/29	45/40/35/29
ODU Sound Pressure ± 3 dB(A)	47	47	51	53
Indoor Unit (Net/Shipping Weight lbs.)	17/20	23/28	28/33	28/44
Outdoor Unit (Net/Shipping Weight lbs.)	62/67	62/67	76/81	95/104
Power/Communication Cable <sup>4</sup> (No. x AWG)	4 x 18			
<i>Compressor</i>				
Compressor Type (Qty)	Single Rotary (1)	Single Rotary (1)	Twin Rotary (1)	Twin Rotary (1)
<i>Fan</i>				
Indoor Type (Qty)	Cross Flow (1)			
Outdoor Type (Qty)	Propeller (1)			
Motor/Drive	Brushless Digital Controlled/Direct			
<i>Airflow Rate</i>				
Indoor - Max/H/M/L (CFM)	318/276/226/177	424/353/272/212	629/512/441/353	689/600/494/388
Outdoor - Max (CFM)	953	953	1,342	1,766
<i>Piping</i>				
Liquid Line (in, OD)	1/4	1/4	1/4	1/4
Vapor Line (in, OD)	3/8	3/8	1/2	5/8
Condensation Line (OD   ID)	27/32, 5/8	27/32, 5/8	27/32, 5/8	27/32, 5/8
Additional Refrigerant Charge (oz/ft)	0.22	0.22	0.33	0.33
Pipe Length <sup>5</sup> (ft) (Min./Max.)	9.8/49.2	9.8/49.2	9.8/65.6	9.8/65.6
Piping Length (no add'l refrigerant, ft) <sup>5</sup>	24.6	24.6	24.6	24.6
Max Elevation Difference (ft)	22.9	22.9	32.8	32.8

EEV: Electronic Expansion Valve IDU: Indoor Unit ODU: Outdoor Unit

<sup>1</sup>Power Input is rated at high speed.

<sup>2</sup>Take appropriate actions at the end of HVAC equipment life to recover, recycle, reclaim or destroy R410A refrigerant according to applicable regulations (40 CFR Part 82, Subpart F) under section 608 of CAA.

<sup>3</sup>Sound Pressure levels are tested in an anechoic chamber under ISO Standard 1996.

<sup>4</sup>Power/communication cables from the outdoor unit to the indoor unit to be minimum 18 AWG, 4-conductor, stranded, shielded or unshielded (if shielded, it must be grounded to the chassis at the outdoor unit only) and must comply with applicable and national code.

<sup>5</sup>Piping lengths are equivalent.

Power wiring to the outdoor unit is field supplied, solid or stranded, and must comply with the applicable local and national codes.

This unit comes with a dry helium charge.

This data is rated 0 ft above sea level with 24.6 of refrigerant line per indoor unit and a 0 ft level difference outdoor and indoor units.

Cooling capacity rating obtained with air entering the indoor unit at 80°F dry bulb (DB) and 67°F wet bulb (WB) and outdoor ambient conditions of 95°F dry bulb (DB) and 75°F wet bulb (WB). Heating capacity rating obtained with air entering the indoor unit at 70°F dry bulb (DB) and 59°F wet bulb (WB) and outdoor ambient conditions of 47°F dry bulb (DB) and 43°F wet bulb (WB).



# GENERAL DATA

## Single Zone Mega115V Unit Specifications

Table 6: Single Zone Mega 115V Unit Specifications

Type	Single Zone Mega Inverter	
System (Model IDU/ODU)	LS090HXV (LSN090HXV/LSU090HXV)	LS120HXV (LSN120HXV/LSU120HXV)
Nominal Cooling Capacity (Btu/h)	8,500	12,000
Cooling Power Input <sup>1</sup> (kW)	0.71	1.14
Nominal Heating Capacity (Btu/h)	10,900	13,000
Heating Power Input <sup>1</sup> (kW)	0.88	1.09
COP	3.63	3.50
EER	12.01	10.5
SEER	17.0	17.0
HSPF	9.0	9.0
Power Supply (V / Hz / Ø)	115/60/1	
<i>ODU Operating Range</i>		
Cooling (°F DB)	14-118	
Heating (°F WB)	14-75	
<i>IDU Operating Range</i>		
Cooling (°F WB)	64-90	
Heating (°F DB)	60-86	
<i>Indoor Temperature Setting Range</i>		
Cooling (°F)	65-86	
Heating (°F)	61-86	
<i>Unit Data</i>		
Refrigerant Type <sup>2</sup>	R410A	
Refrigerant Control	EEV	
IDU Sound Pressure <sup>3</sup> ± 3 dB(A) (H/M/L)	39/33/25	39/33/25
ODU Sound Pressure ± 3 dB(A)	47	47
Indoor Unit (Net/Shipping Weight lbs.)	23/26	23/26
Outdoor Unit (Net/Shipping Weight lbs.)	67/79	67/79
Power/Communication Cable <sup>4</sup> (No. x AWG)	4 x 18	
<i>Compressor</i>		
Compressor Type (Qty)	Single Rotary (1)	Single Rotary (1)
<i>Fan</i>		
Indoor Type (Qty)	Cross Flow (1)	
Outdoor Type (Qty)	Propeller (1)	
Motor/Drive	Brushless Digitally Controlled/Direct	
<i>Airflow Rate</i>		
Indoor - Max/H/M/L (CFM)	335/272/212/124	335/272/212/124
Outdoor - Max (CFM)	1,000	1,000
<i>Piping</i>		
Liquid Line (in, OD)	1/4	1/4
Vapor Line (in, OD)	3/8	3/8
Condensation Line (OD   ID)	27/32   5/8	27/32   5/8
Additional Refrigerant Charge (oz/ft)	0.22	0.22
Pipe Length <sup>5</sup> (ft) (Min./Max.)	6.6/49.2	6.6/49.2
Piping Length (no add'l refrigerant, ft) <sup>5</sup>	24.6	24.6
Max Elevation Difference (ft)	23	23

EEV: Electronic Expansion Valve IDU: Indoor Unit ODU: Outdoor Unit

<sup>1</sup>Power Input is rated at high speed.

<sup>2</sup>Take appropriate actions at the end of HVAC equipment life to recover, recycle, reclaim or destroy R410A refrigerant according to applicable regulations (40 CFR Part 82, Subpart F) under section 608 of CAA.

<sup>3</sup>Sound Pressure levels are tested in an anechoic chamber under ISO Standard 1996.

<sup>4</sup>Power/communication cables from the outdoor unit to the indoor unit to be minimum 18 AWG, 4-conductor, stranded, shielded or unshielded (if shielded, it must be grounded to the chassis at the outdoor unit only) and must comply with applicable and national code.

<sup>5</sup>Piping lengths are equivalent.

Power wiring to the outdoor unit is field supplied, solid or stranded, and must comply with the applicable local and national codes.

This unit comes with a dry helium charge.

This data is rated 0 ft above sea level with 24.6 of refrigerant line per indoor unit and a 0 ft level difference outdoor and indoor units.

Cooling capacity rating obtained with air entering the indoor unit at 80°F dry bulb (DB) and 67°F wet bulb (WB) and outdoor ambient conditions of 95°F dry bulb (DB) and 75°F wet bulb (WB).

Heating capacity rating obtained with air entering the indoor unit at 70°F dry bulb (DB) and 59°F wet bulb (WB) and outdoor ambient conditions of 47°F dry bulb (DB) and 43°F wet bulb (WB).

# GENERAL DATA

## Electrical

Table 7: Single Zone High Efficiency Indoor Unit Electrical Data

Model Number	Nom. Tons	Compressor Qty	Compressor (A) Cool/Heat	Fan Qty	ODU Fan (A)	IDU Fan (A)	MCA (A)	MOP (A)
LSU091HSV3	3/4	1	8.7/8.7	1	0.40	0.4	10	15
LSU121HSV3	1	1	8.7/8.7	1	0.40	0.4	10	15
LSU181HSV3	1-1/2	1	15.4/15.4	1	0.25	0.4	19	25
LSU240HSV3	1-3/4	1	15.4/15.4	1	0.25	0.5	19	25

Table 8: Single Zone Standard Indoor Unit Electrical Data

Model Number	Nom. Tons	Compressor Qty	Compressor (A) Cool/Heat	Fan Qty	ODU Fan (A)	IDU Fan (A)	MCA (A)	MOP (A)
LSU307HV3	2-1/2	1	15.4/15.4	1	0.25	0.5	19	25
LSU360HV3	2-3/4	1	15.4/15.4	1	0.25	0.5	19	25

Table 9: Single Zone Extended Pipe Indoor Unit Electrical Data

Model Number	Nom. Tons	Compressor Qty	Compressor (A) Cool/Heat	Fan Qty	ODU Fan (A)	IDU Fan (A)	MCA (A)	MOP (A)
LSU240HLV	1-3/4	1	17.3/17.3	1	0.25	0.5	23	35
LSU300HLV	2-1/2	1	17.3/17.3	1	0.25	0.5	23	35
LSU360HLV	2-3/4	1	17.3/17.3	1	0.25	0.5	23	35

Table 10: 208-230V, 60Hz, 1-Phase Single Zone Mega (HEV) Indoor Unit Electrical Data

Unit Model Nos.	Nom. Tons	Compressor Qty	Compressor (A) Cool/Heat	Fan Qty	ODU Fan (A)	IDU Fan (A)	MCA (A)	MOP (A)
LSU090HEV	3/4	1	6.8/6.8	1	0.5	0.5	9	15
LSU120HEV	1	1	6.8/6.8	1	0.5	0.5	9	15
LSU180HEV	1-1/2	1	8.68/9.28	1	0.4	0.4	12	20
LSU240HEV	2	1	10.8/9.6	1	0.48	0.48	14	20

Table 11: 208-230V, 60Hz, 1-Phase Single Zone Mega (HEV1) Indoor Unit Electrical Data

Unit Model Nos.	Nom. Tons	Compressor Qty	Compressor (A) Cool/Heat	Fan Qty	ODU Fan (A)	IDU Fan (A)	MCA (A)	MOP (A)
LSU090HEV1	3/4	1	7.0/7.0	1	0.5	0.5	10	15
LSU120HEV1	1	1	7.0/7.0	1	0.5	0.5	10	15
LSU180HEV1	1-1/2	1	8.81/8.61	1	0.4	0.4	12	20
LSU240HEV1	2	1	10.72/10.28	1	0.4	0.4	15	20

Table 12: 115V, 60Hz, 1-Phase Single Zone Mega 115V Indoor Unit Electrical Data

Unit Model Nos.	Nom. Tons	Compressor Qty	Compressor (A) Cool/Heat	Fan Qty	ODU Fan (A)	IDU Fan (A)	MCA (A)	MOP (A)
LSU090HXV	3/4	1	10/10	1	0.4	0.5	13.5	20
LSU120HXV	1	1	10/10	1	0.4	0.5	13.5	20

Voltage tolerance is  $\pm 10\%$ .

Maximum allowable voltage unbalance is 2%.

MSC = Maximum Starting Current.

MCA = Minimum Circuit Ampacity.

Maximum Overcurrent Protection (MOP) is calculated as follows: (Largest motor FLA x 2.25) + (Sum of other motor FLA) rounded down to the nearest standard fuse size.

# GENERAL DATA

## R410A Refrigerant

---

---

### R410A Refrigerant

R410A refrigerant has a higher operating pressure in comparison to R22 refrigerant and, therefore, all piping system materials installed must have a higher resisting pressure than the materials traditionally used in R22 systems.

R410A refrigerant is an azeotrope of R32 and R125, mixed at 50:50, so the ozone depletion potential (ODP) is 0. Many countries have approved of and encouraged R410A for use as an alternate refrigerant.

#### **⚠ DANGER**

⊘ Do not use any piping that has not been approved for use in high-pressure refrigerant systems. There is risk of fire, explosion and physical injury or death. Improper piping may also cause refrigerant leaks. If the refrigerant leaks and safety limits are exceeded, it could result in personal injuries or death from oxygen depletion.

#### **⚠ WARNING**

⊘ Do not place the refrigerant cylinder in direct sunlight. There is risk of fire, explosion, and physical injury or death.

#### **Note:**

- ⊘ Do not use any piping that has not been approved for use in high-pressure refrigerant systems. Improper piping may cause refrigerant leaks and system malfunction.
- Piping wall thickness must comply with the applicable local, state, and federal codes for the 551 psi design pressure of R410A.
- Because R410A is a combination of R32 and R125, the required additional refrigerant must be charged in its liquid state. If the refrigerant is charged in its gaseous state, its composition changes and the system will not work properly.



# GENERAL INSTALLATION GUIDELINES

## Location Selection

---

---

### Selecting the Best Location

#### **⚠ DANGER**

- To avoid the possibility of fire, Ⓣ do not install the unit in an area where combustible gas may generate, flow, stagnate, or leak.
- Ⓣ Do not install the unit in a location where acidic solution and spray (sulfur) are often used as it can cause bodily injury or death.
- Ⓣ Do not use the unit in environments where oil, steam, or sulfuric gas are present as it can cause bodily injury or death.

#### **⚠ WARNING**

Install a fence to prevent vermin from crawling into the unit or unauthorized individuals from accessing it.

#### **Note:**

Select a location for installing the outdoor unit that will meet the following conditions:

- Where the unit will not be subjected to direct thermal radiation from other heat sources.
- Where operating sound from the unit will not disturb inhabitants of surrounding buildings.
- Where the unit will not be exposed to direct, strong winds.
- Where there is enough strength to bear the weight of the unit.
- Include space for drainage to ensure condensate flows properly out of the unit when it is in heating mode.
- Include enough space for air flow and for service access.

#### **Note:**

To ensure the outdoor unit operates properly, certain measures are required in locations where there is a possibility of heavy snowfall or severe wind-chill or cold:

1. Prepare for severe winter wind chills and heavy snowfall, even in areas of the country where these are unusual phenomena.
2. Position the outdoor unit so that its airflow fans are not buried by direct, heavy snowfall. If snow piles up and blocks the airflow, the system may malfunction.
3. Remove any snow that has accumulated 3-15/16 inches or more on the top of the outdoor unit.
4. Place the outdoor unit on a raised platform at least 19-11/16 inches higher than the average annual snowfall for the area. In environments where there is a possibility of heavy snow, the frame height must be more than two (2) times the amount of average annual snowfall, and should not exceed the width of the outdoor unit. If the frame width is wider than the outdoor unit, snow may accumulate.
5. Install a snow protection hood.
6. To prevent snow and heavy rain from entering the outdoor unit, install the suction and discharge ducts facing away from direct winds.
7. Additionally, the following conditions should be taken into consideration when the unit operates in defrost mode:
  - If the outdoor unit is installed in a highly humid environment (near an ocean, lake, etc.), ensure that the site is well-ventilated and has a lot of natural light. (Example: Install on a rooftop.)
  - Sidewalks or parking lots near the outdoor unit may accumulate moisture after unit operates in defrost mode that can turn to ice.

#### **Note:**

The indoor unit may take longer to provide heat, or heating performance will be reduced in winter if the unit is installed:

1. In a narrow, shady location.
2. Near a location that has a lot of ground moisture.
3. In a highly humid environment.
4. In an area in which condensate does not drain properly.

### Ambient Air Conditions

#### **Note:**

- Avoid exposing the outdoor unit to steam, combustible gases, or other corrosive elements.
- Avoid exposing the unit to discharge from boiler stacks, chimneys, steam relief ports, other air conditioning units, kitchen vents, plumbing vents, or substances that may degrade performance or cause damage to the unit.
- When installing multiple outdoor units, avoid placing the units where discharge of one outdoor unit will blow into the inlet side of an adjacent unit.

#### **⚠ WARNING**

Avoid exposing the unit to sources of extreme temperature or gases to prevent serious bodily injury.

# GENERAL INSTALLATION GUIDELINES

## Oceanside Applications

### Oceanside Applications

#### Use of a Windbreak to Shield from Sea Wind

**Note:**

Ocean winds may cause corrosion, particularly on the condenser and evaporator fins, which, in turn could cause product malfunction or inefficient performance.

- Avoid installing the outdoor unit where it would be directly exposed to ocean winds.
- Install the outdoor unit on the side of the building opposite from direct ocean winds.
- Select a location with good drainage.
- Periodically clean dust or salt particles off of the heat exchanger with water.
- If the outdoor unit must be placed in a location where it would be subjected to direct ocean winds, install a concrete windbreak strong enough to block any winds.
- Windbreak should be more than 150% of the outdoor unit's height. There must be 2 to 3-1/2 inches of clearance between the outdoor unit and the windbreaker for purposes of air flow.

#### Use of a Building to Shield from Sea Wind

If a windbreak is not possible, a building or larger structure must be used to shield the outdoor unit from direct exposure to the sea wind. The unit should be placed on the side of the building directly opposite to the direction of the wind as shown in Figure 2.

Figure 1: Oceanside Placement Using Windbreak

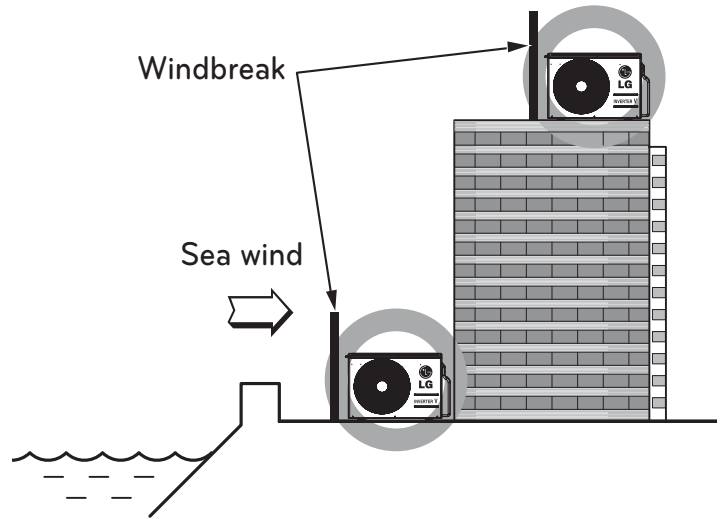

**Note:**

Additional anti-corrosion treatment may need to be applied to the outdoor unit at oceanside locations.

Figure 2: Placement Using Building as Shield

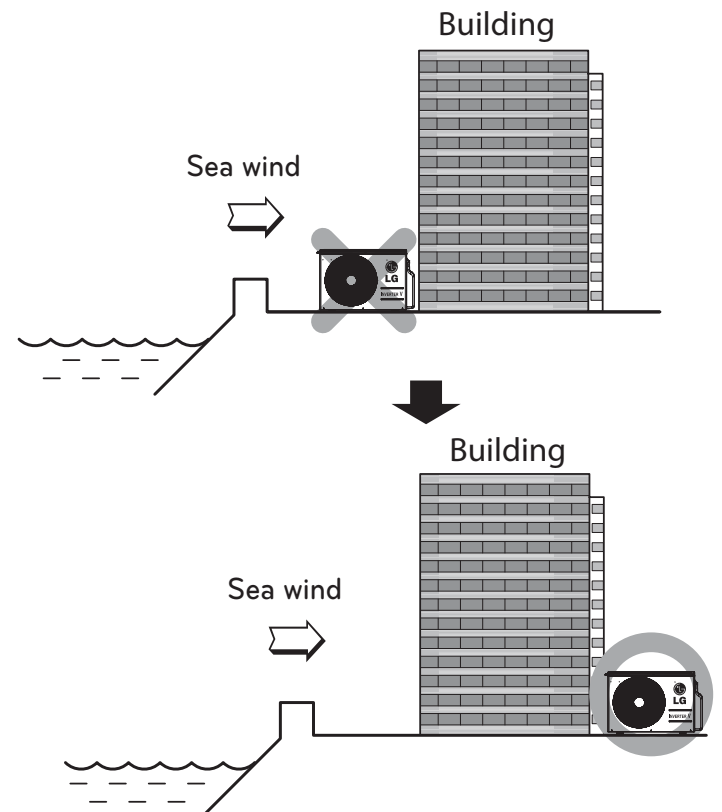

# GENERAL INSTALLATION GUIDELINES

## Mounting Bolt Location

### General Mounting

Securely attach the outdoor unit to a condenser pad, base rails, or another mounting platform that is securely anchored to the ground or building structure. Attach the outdoor unit with a bolt and nut on a concrete or rigid mount. See Figure 3. Follow applicable local codes for clearance, mounting, anchor and vibration attenuation requirements.

**Note:**

All referenced materials are to be field-supplied. Images are not to scale.

### Mounting Platform

The underlying structure or foundation must be designed to support the weight of the unit. Avoid placing the unit in a low lying area where water may accumulate. When installing the outdoor unit on the wall or roof top, anchor the mounting base securely to account for wind, earthquakes or vibration.

Figure 3: Outdoor Unit Mounting Methods

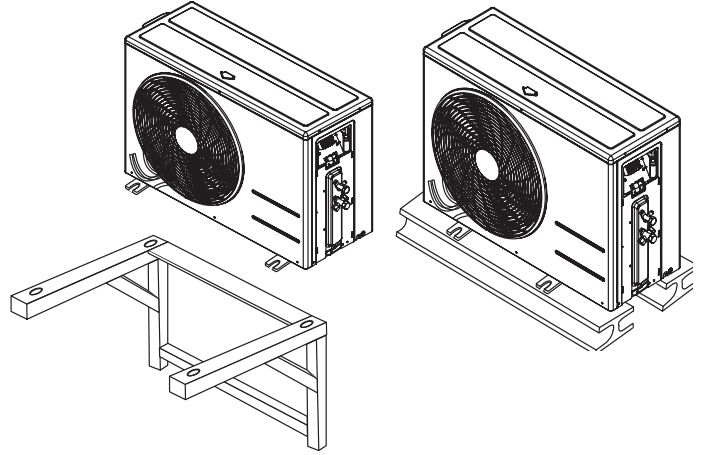

### Tie-Downs and Wind Restraints

The strength of the Single Zone system frame is adequate to be used with field-provided wind restraint tie-downs. The overall tie-down configuration must be approved by a local professional engineer.

**Note:**

Always refer to local code when designing a wind restraint system.

### Snow and Ice Conditions

In climates that experience snow build-up, place the unit on a raised platform to ensure condenser airflow. The raised support platform must be high enough to allow the unit to remain above possible snow drifts. Mount the unit on a field-provided snow stand at a minimum height that is equal to the average annual snowfall plus 20 inches. Design the mounting base to prevent snow accumulation on the platform in front or back of the unit case. If necessary, provide a field fabricated hood to keep snow and ice and/or drifting snow from accumulating on the coil surfaces. Use inlet and discharge duct or hoods to prevent snow or rain from accumulating on the fan inlet and outlet guards. Best practice prevents snow from accumulating on top of the unit. Consider tie-down requirements in case of high winds or where required by local codes.

### CAUTION

When deciding on a location to place the outdoor unit, be sure to choose an area where run-off from defrost will not accumulate and freeze on sidewalks or driveways which may create unsafe conditions.

Proper airflow through the Single Zone outdoor unit coil is critical for correct unit operation. When installing, consider service, inlet and outlet, and minimum allowable space requirements as illustrated in the diagrams to follow.

### Minimum Clearance Requirements for Single Zone Systems

#### Outdoor Unit Clearance

Specific clearance requirements in the diagrams on the next page are for the single zone wall mount systems. Figure 4 shows the overall minimum clearances that must be observed for safe operation and adequate airflow around the outdoor unit.

When placing the outdoor unit under an overhang, awning, sunroof or other “roof-like structure, observe the clearance requirements (as shown in Figure 5) for height in relation to the unit. This clearance ensures that heat radiation from the condenser is not restricted around the unit. See Figures 6 and 7 for recommendations when other obstacles are present.

Adhere to all clearance requirements if installing the unit on a roof. Be sure to level the unit and ensure that the unit is adequately anchored. Consult local codes for rooftop mounting requirements.

# GENERAL INSTALLATION GUIDELINES

## Required Clearances

Figure 4: Outdoor Unit Clearances

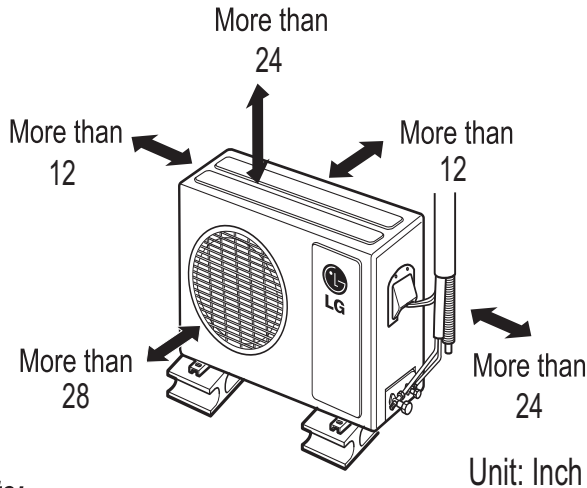
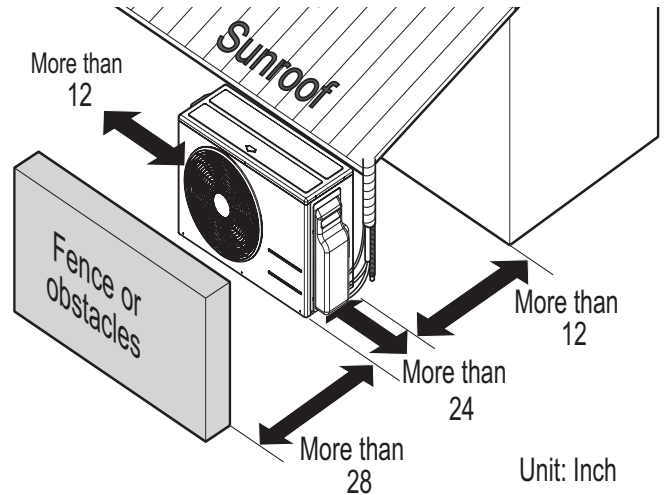

Figure 5: Outdoor Unit Sunroof/Awning Clearances



**Note:**

⊘ Do not place the unit where animals and/or plants will be in the path of the warm air, or where the warm air and/or noise will disturb neighbors.

Figure 6: Clearances Where There Are Obstacles on Both Air Inlet and Outlet Sides (Obstacle on the Outlet Side is Lower Than the Outdoor Unit)

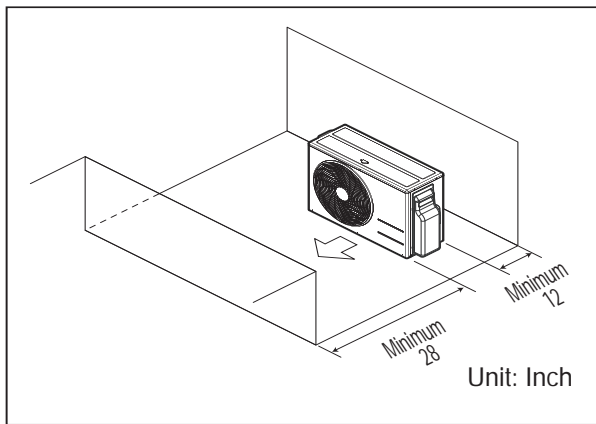
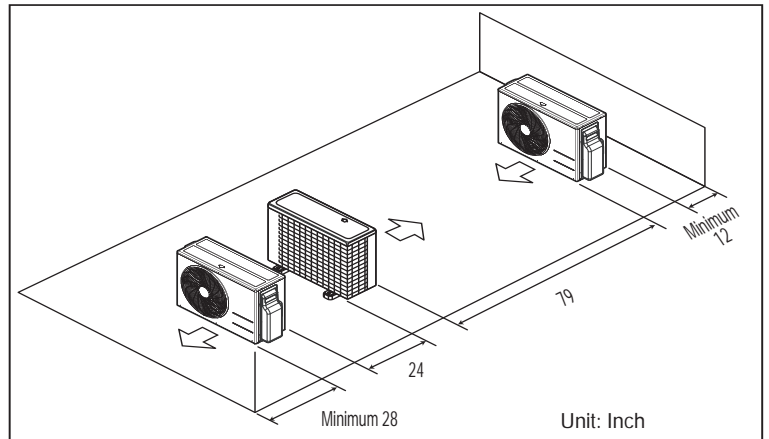

Figure 7: Clearances Where There are Obstacles Above and on Both Air Inlet and Outlet Sides (Obstacle on the Outlet Side is Lower Than the Outdoor Unit)



**Indoor Unit Clearance**

Follow recommended best practices when choosing an indoor location for the Single Zone Wall-Mounted indoor unit.

- Keep unit away from any indoor steam or excessive heat.
- ⊘ No obstacles should be placed around unit.
- Condensation drain (leakage piping) should be routed away from the unit.
- ⊘ Do not install near a doorway.
- Clearance gap between any wall or enclosure and the left or right side of the unit must be greater than 4 inches.
- From the top of the unit to the ceiling there must be greater than 5 or 8 inches of clearance (depending on indoor unit model).
- Unit should be at least 6.5 feet from the floor for adequate clearance.

Figure 8: Single Zone Indoor Unit Clearance Requirements

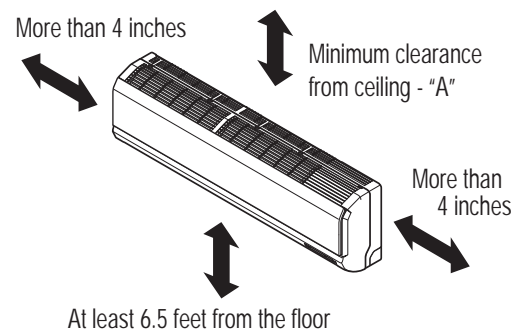

Table 13: Indoor Unit Ceiling Clearance

"A" Ceiling Clearance (inches)	Indoor Unit Model(s)
5	LSN090-120HEV1, LSN091~121HSV3
8	LSN181~240HSV3, LS307-360HV3, LSN240~360HLV, LSN90~240HEV, LSN180-240HEV1, LSN090-120HXV

Due to our policy of continuous product innovation, some specifications may change without notification.  
©LG Electronics U.S.A., Inc., Englewood Cliffs, NJ. All rights reserved. "LG" is a registered trademark of LG Corp.

# GENERAL INSTALLATION GUIDELINES

## Mounting of Indoor Unit Installation Plate

### Mounting Installation Plate to Wall (091HSV3, 121HSV3, 181HSV3)

Follow the procedure and best practices below when mounting the Wall-Mounted indoor unit's plate to a wall.

#### Procedure

1. Before installation of the plate, confirm the position the screw types (A or B) between chassis and installation plate.
2. Mount the installation plate horizontally by aligning the centerline using a leveling tool.
3. Use provided screws when mounting the plating.
  - If mounting the unit on concrete wall, use field supplied anchor bolts.
4. Choose what side (left or right) to install the piping, and then observe the left and right rear piping clearances when drilling into the wall, as shown in Figures 9, 11, 12.

#### Note:

Select location carefully. Unit should be anchored to a strong wall to prevent unnecessary vibration.

#### ⚠ WARNING

- When choosing a location for the wall mount plate, be sure to take into consideration routing of wiring for power outlets within the wall. Contacting wiring can cause serious bodily injury, or death.
- Use caution when drilling holes through the walls for the purposes of piping connections. Power wiring can cause serious bodily injury, or death.

Refer to "Drilling Piping Hole in the Wall" on page 22 as you follow procedure to install the plate.

Figure 9: Installation Plate Screws - 091HSV3, 121HSV3

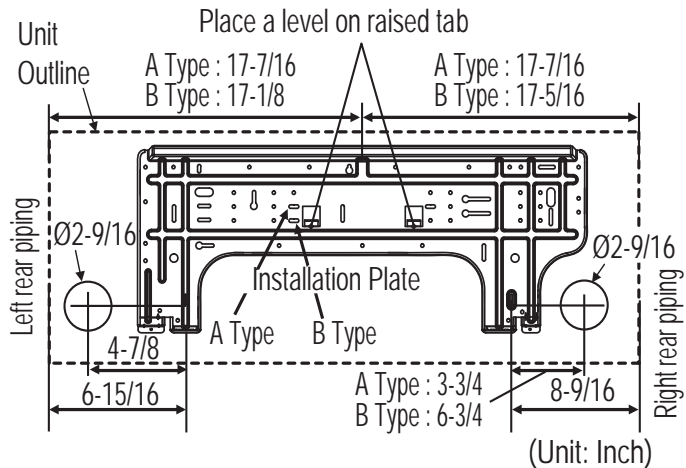

Figure 10: Installation Plate Screws

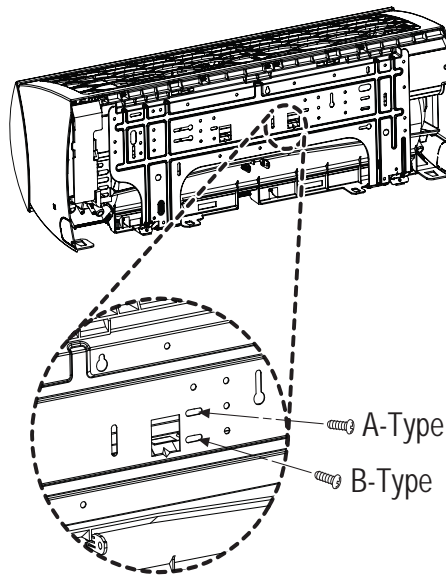

Figure 11: Installation Plate - 091HSV3, 121HSV3

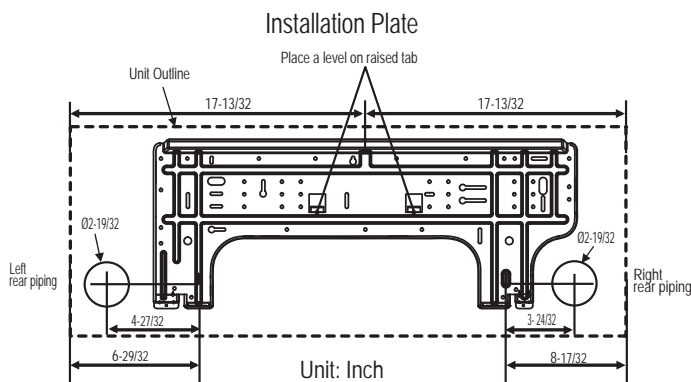
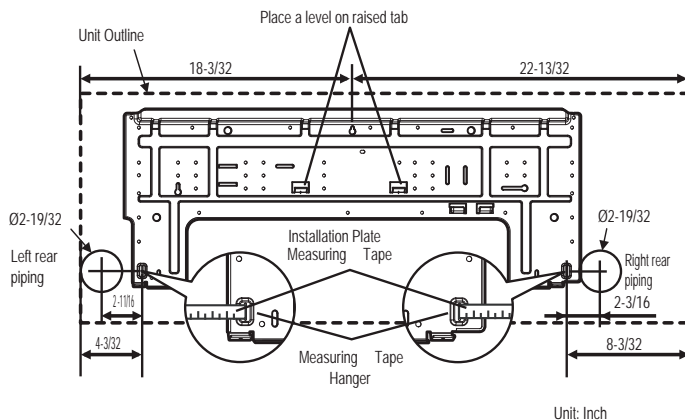

Figure 12: Installation Plate - 181HSV3





# GENERAL INSTALLATION GUIDELINES

## Mounting of Indoor Unit Installation Plate

### Mounting Installation Plate to Wall (240HSV3, HV3, HLV)

Follow the procedure and best practices when mounting the indoor unit's plate to a wall.

#### Procedure

1. Mount the installation plate horizontally by aligning the centerline using a leveling tool (Figure 13).
2. Use type "A" screws when mounting the plating (these screws come with the plate).
  - If mounting the unit on concrete wall, use field supplied anchor bolts.
3. Observe the left and right rear piping clearance when drilling into the wall, as shown in Figure 14.

#### Note:

Select location carefully. Unit should be anchored to a strong wall to prevent unnecessary vibration.

#### ⚠ WARNING

- When choosing a location for the wall mount plate, be sure to take into consideration routing of wiring for power outlets within the wall. Contacting wiring can cause serious bodily injury, or death.
- Use caution when drilling holes through the walls for the purposes of piping connections. Power wiring can cause serious bodily injury, or death.

### Drilling Piping Hole in the Wall

Follow the left or right piping clearance recommendations.

1. Using a 2-5/8 (Ø 65mm) inch hole core drill bit, drill a hole at either the right or left side of the wall mounting (Figure 15).
- The slant of the hole should be 3/16" to 5/16" from level with the slant being upward on the indoor unit side and downward on the outdoor unit side.
2. Finish off the newly drilled hole as shown with bushing and sleeve covering.
- Sleeve and bushing prevents damage to the tubing/bundling of the piping.

See *Refrigerant Piping Connections for Indoor Unit* on page 43 to proceed with piping.

Figure 13: Installation Plate - Mounting

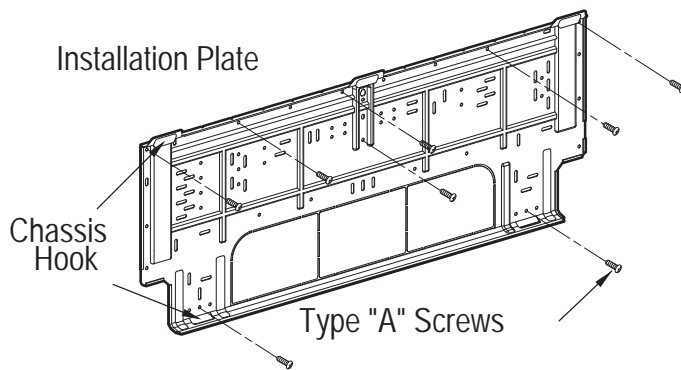

Figure 14: Installation Plate - Mounting

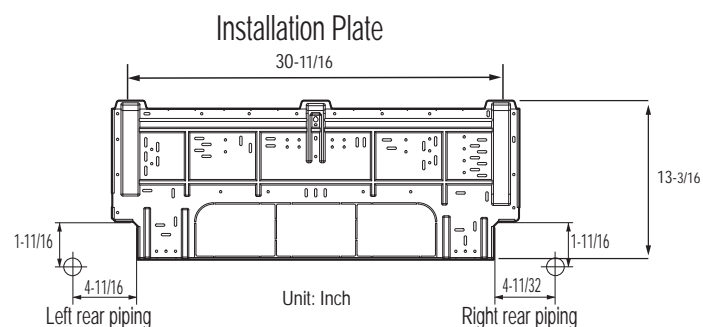
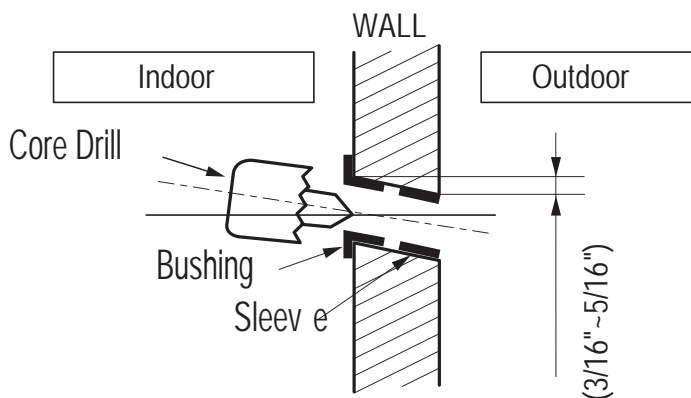

Figure 15: Drilling Piping Hole





# GENERAL INSTALLATION GUIDELINES

## Mounting of Indoor Unit Installation Plate

### Mounting Installation Plate to Wall (Mega 090HEV, 090HEV1, 120HEV, 120HEV1)

1. Confirm the position of screws between chassis and installation plate (Figure 16 and Figure 17).
2. Mount the installation plate horizontally by aligning the centerline using a leveling tool (Figure 18 and Figure 19).
3. Use provided screws when mounting the plating.
  - If mounting the unit on concrete wall, use field supplied anchor bolts.
4. Observe the left and right rear piping clearance when drilling into the wall as shown in Figure 18 (090HEV) and Figure 19 (120HEV).

**Note:**

Select location carefully. Unit should be anchored to a strong wall to prevent unnecessary vibration.

**⚠ WARNING**

- When choosing a location for the wall mount plate, be sure to take into consideration routing of wiring for power outlets within the wall. Contacting wiring can cause serious bodily injury, or death.
- Use caution when drilling holes through the walls for the purposes of piping connections. Power wiring can cause serious bodily injury, or death.

Refer to "Drilling Piping Hole in the Wall" on page 22 as you follow procedure to install plate.

Figure 16: Installation Plate Screw Type A - 090HEV, 090HEV1, 120HEV, 120HEV1

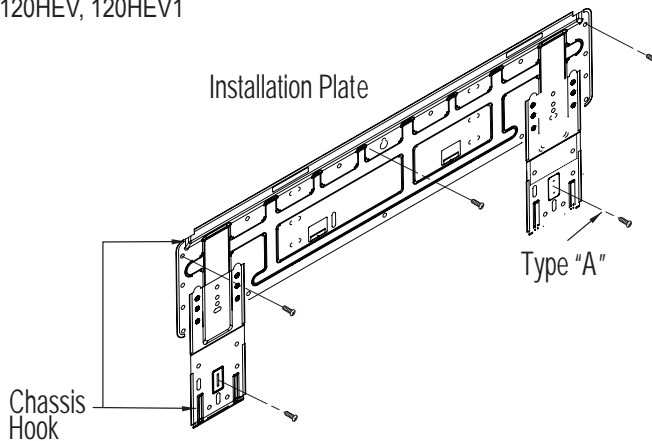

Figure 17: Installation Plate Screws Type A, Type B - 120HEV, 120HEV1

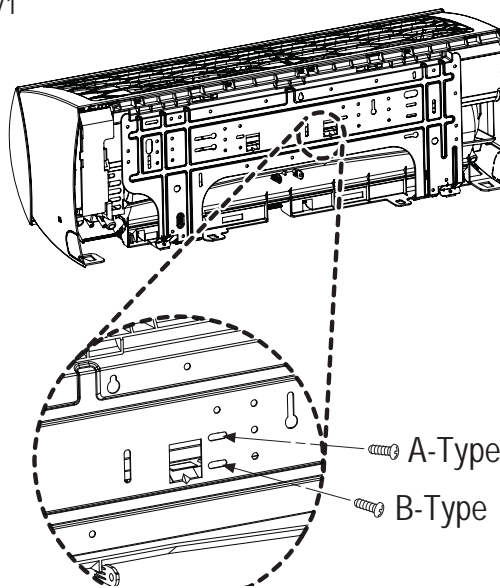

Figure 18: Installation Plate - 090HEV and 090HEV1

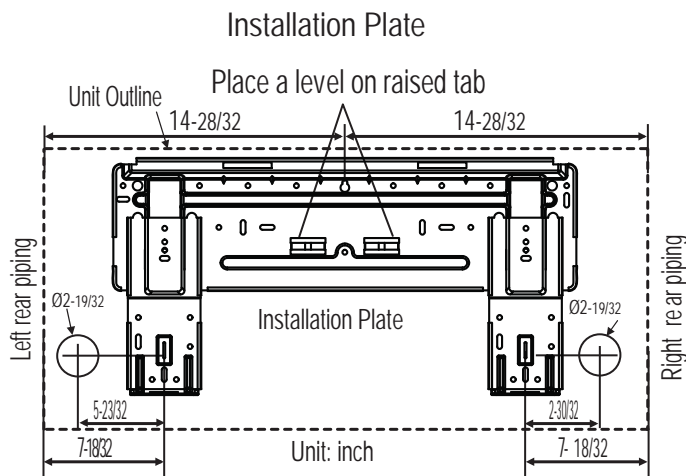
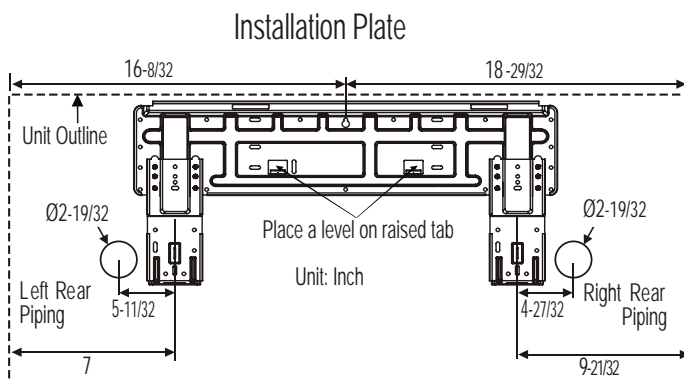

Figure 19: Installation Plate - 120HEV and 120HEV1



# GENERAL INSTALLATION GUIDELINES

## Mounting of Indoor Unit Installation Plate

### Mounting Installation Plate to Wall (Mega 180HEV, 180HEV1, 240HEV, 240HEV1)

1. Confirm the position of screws between chassis and installation plate (Figures 20 and 23).
2. Mount the installation plate horizontally by aligning the centerline using a leveling tool (Figures 21 and 22).
3. Use provided screws when mounting the plating.
  - If mounting the unit on concrete wall, use field supplied anchor bolts.
4. Observe the left and right rear piping clearance when drilling into the wall, as shown in Figures 21 and 22.

**Note:**

Select location carefully. Unit should be anchored to a strong wall to prevent unnecessary vibration.

**⚠ WARNING**

- When choosing a location for the wall mount plate, be sure to take into consideration routing of wiring for power outlets within the wall. Contacting wiring can cause serious bodily injury, or death.
- Use caution when drilling holes through the walls for the purposes of piping connections. Power wiring can cause serious bodily injury, or death.

Refer to "Drilling Piping Hole in the Wall" on page 22 as you follow procedure to install plate.

Figure 20: Installation Plate Showing Screw Locations - 180HEV, 240HEV

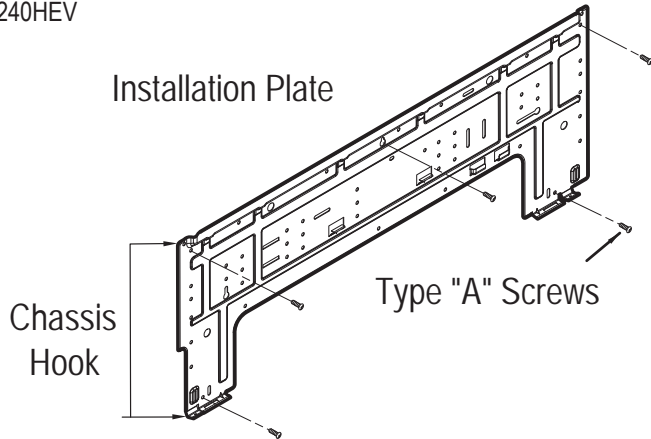

Figure 23: Installation Plate Showing Screw Locations - 180HEV1, 240HEV1

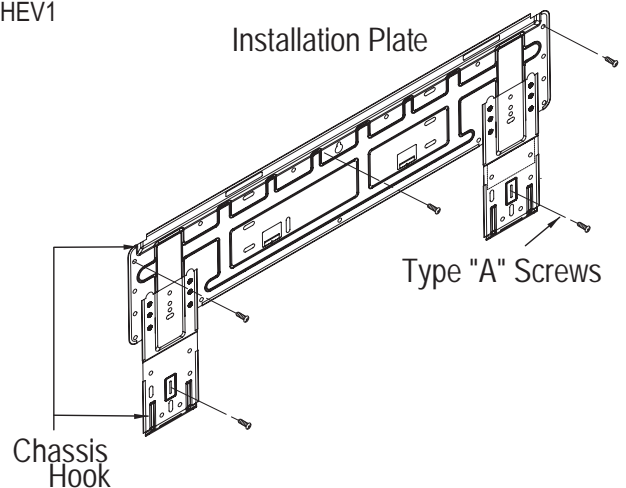

Figure 21: Installation Plate - 180HEV, 240HEV

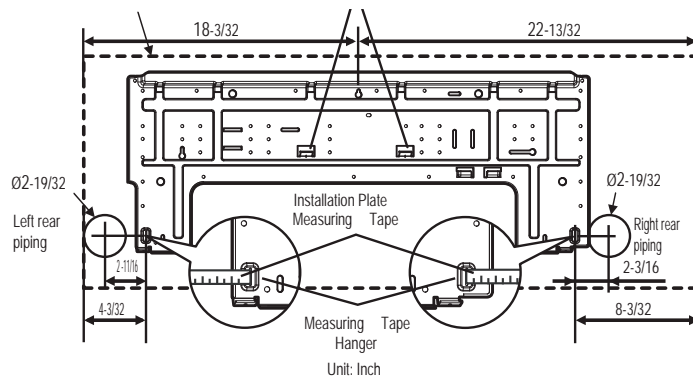
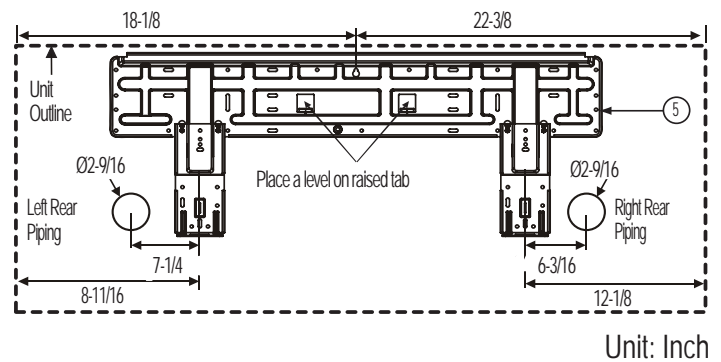

Figure 22: Installation Plate - 180HEV1, 240HEV1



**Note:**

Installation plate for 180HEV, 240HEV can also be used for 180HEV1 and 240HEV1.

# GENERAL INSTALLATION GUIDELINES

## Mounting of Indoor Unit Installation Plate

### Mounting Installation Plate to Wall (Mega 115V - HXV Models)

Follow the procedure and best practices when mounting the indoor unit's plate to a wall.

#### Procedure

1. Mount the installation plate horizontally by aligning the centerline using a leveling tool (Figure 24).
2. Use type "A" screws when mounting the plating (these screws come with the plate).
  - If mounting the unit on concrete wall, use field supplied anchor bolts.
3. Observe the left and right rear piping clearance when drilling into the wall, as shown in Figure 25.

#### Note:

Select location carefully. Unit should be anchored to a strong wall to prevent unnecessary vibration.

#### ⚠ WARNING

- When choosing a location for the wall mount plate, be sure to take into consideration routing of wiring for power outlets within the wall. Contacting wiring can cause serious bodily injury, or death.
- Use caution when drilling holes through the walls for the purposes of piping connections. Power wiring can cause serious bodily injury, or death.

Figure 24: Installation Plate - Mounting Mega 115V

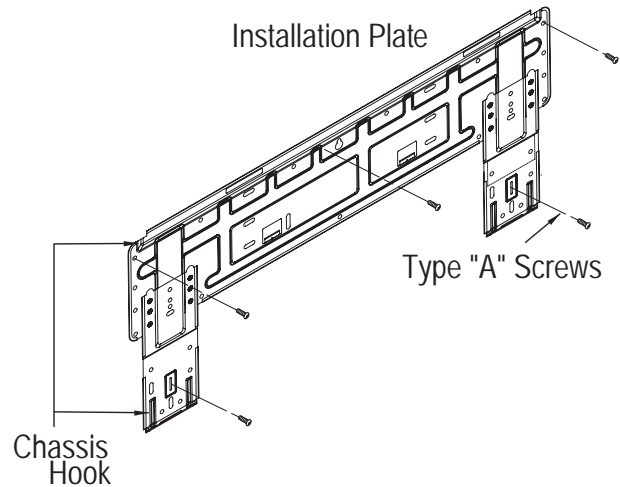

Refer to "Drilling Piping Hole in the Wall" on page 22 as you follow procedure to install plate.

Figure 25: Installation Plate - Mega 115V

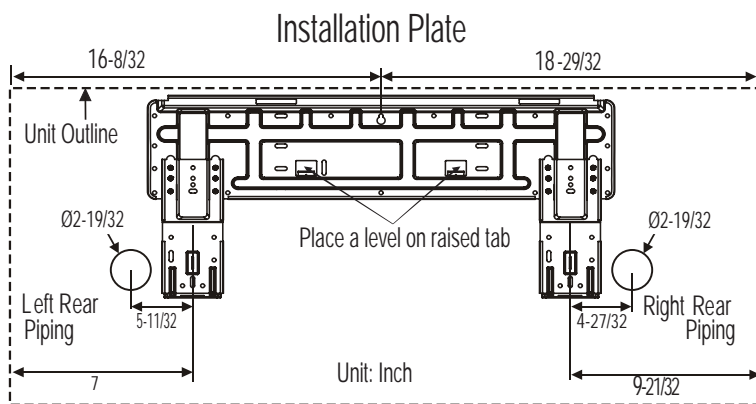

# GENERAL INSTALLATION GUIDELINES

## Mounting of Indoor Unit

### Mounting the Indoor Unit to the Installation Plate

1. Hook the indoor unit onto the upper portion of the installation plate ([1] Figure 26).
2. Engage the hooks at the top of the indoor unit with the upper edge of the installation plate.
  - Ensure that the hooks are properly seated on the installation plate by moving it left and right.
3. Move the bottom of indoor unit towards the installation plate to anchor to wall ([2] Figure 26).
  - It helps to press the lower left and right sides of the unit against the installation plate until the hooks engage into their slots.
  - You will hear a clicking sound as the bottom attaches to the installation plate successfully.
4. Finish by inserting and tightening two type "C" screws into the bottom of the installation plate (Figure 28).
  - Pay attention to the positioning of the piping through any wall as shown in the figure, as you insert the screws to the indoor unit.

#### Preparing for Piping/ Electrical Connection

1. To prepare indoor unit for piping, disengage bottom on indoor unit from installation plate by reversing step 3 from previous procedure.
  - This step will separate the indoor unit's bottom side from the wall mount in order to route drain hose correctly. See Figure 29 for a reference of the rear view of the indoor unit.
2. Swing drain hose holder (L-bracket) out and anchor as shown in Figure 27, against installation plate.
3. Optionally, go to *Refrigerant Piping Connections* section of this manual to continue with piping connections to the indoor unit.
4. Optionally, go to *Electrical Connections* section of this manual to continue with conduit/electrical wiring to the indoor unit.

Figure 29: Rear View of IDU

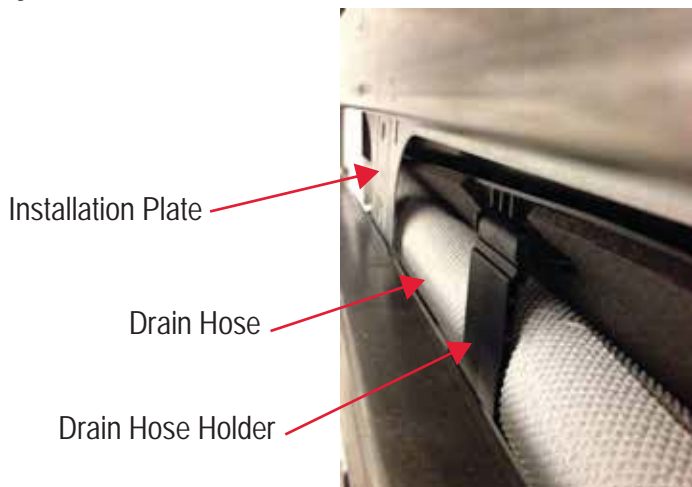

Figure 26: Mounting Unit on Installation Plate

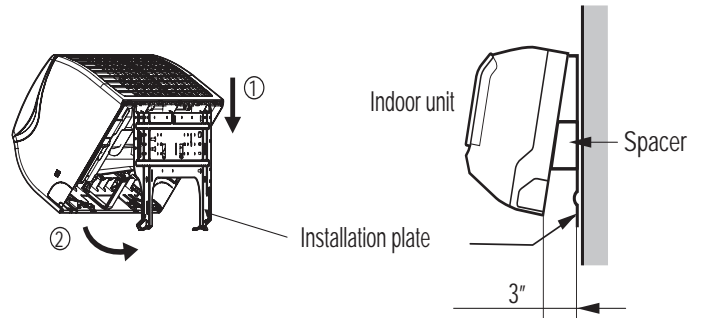

Figure 27: Mounting Unit on Installation Plate

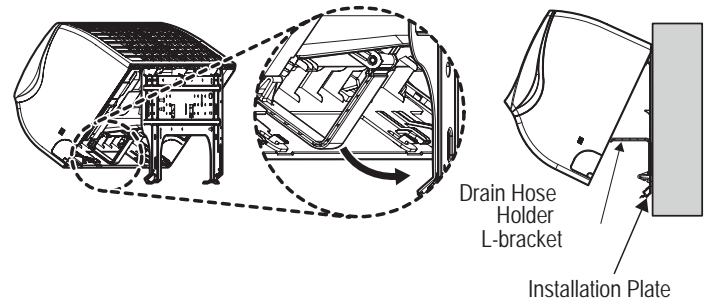
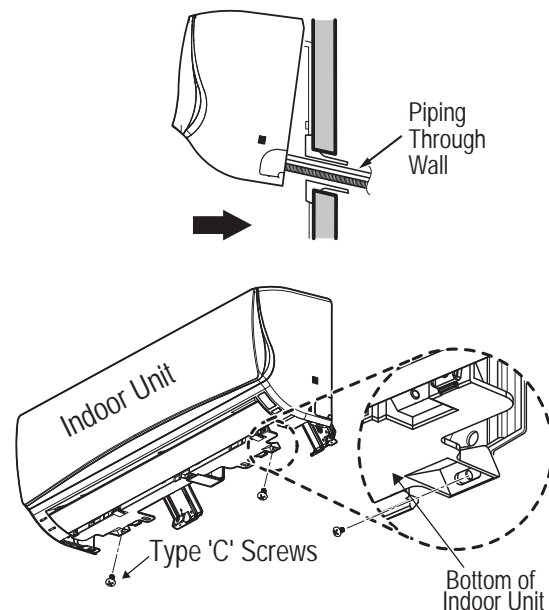

Figure 28: Mounting Bottom of Unit to Installation Plate



# GENERAL INSTALLATION GUIDELINES

## Piping Preparation

### Piping Preparation

#### ⚠ WARNING

- Do not allow the refrigerant to leak during brazing; if the refrigerant combusts, it generates a toxic gas which can cause physical injury or death.
- Do not braze in an enclosed location, and always test for gas leaks before / after brazing. Gas leaks can cause physical injury or death.
- After brazing, check for refrigerant gas leaks. Refrigerant gas leaks can cause physical injury or death.

### Single Zone Pipe Connections

#### Note:

1. Do not use kinked pipe caused by excessive bending in one specific area on its length.
2. Braze the pipes to the service valve pipe stub of the outdoor unit.

### Creating a Flare Fitting

#### Note:

One of the main causes of refrigerant leaks is defective flared connections. Create flared connections using the procedure at right (Figure 31).

1. Cut the pipe to length.
  - Measure the distance between the indoor unit and the outdoor unit.
  - Cut the pipes a little longer than measured distance.
  - Cut the cable 4.9 ft longer than the pipe length.
- 2A. Remove the burrs.
  - Completely remove all burrs from pipe ends.
  - When removing burrs, point the end of the copper pipe down to avoid introducing foreign materials in the pipe.
- 2B. Slide the flare nut onto the copper tube.
3. Flaring the pipe end.
  - Use the proper size flaring tool to finish flared connections as shown.
  - ALWAYS create a 45° flare when working with R410A. See Warning on this page.
4. Carefully inspect the flared pipe end.
  - Compare the geometry with the figure to the right and dimensions as detailed in Figure 30.
  - If the flare is defective, cut it off and re-do procedure.
  - If flare looks good, blow clean the pipe with dry nitrogen.

Figure 30: Dimensions of the Flare

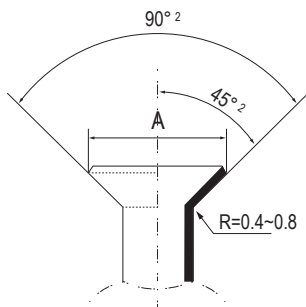

#### ⚠ WARNING

When selecting flare fittings, always use a 45° fitting rated for use with high pressure refrigerant R410A. Failure to do so may result in refrigerant leaks which in turn could result in personal injuries or death from oxygen depletion. Selected fittings must also comply with local, state, or federal standards.

Figure 31: Creating a Flare Fitting

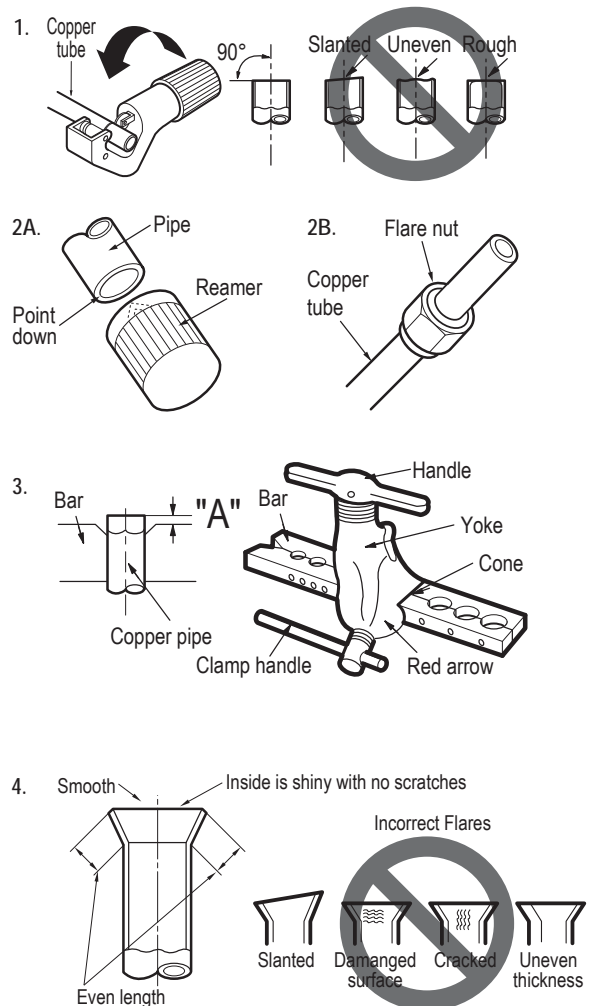

Table 14: Flared Connection Dimensions

Pipe		"A"		Thickness	
Vapor (in. O.D.)	Liquid (in. O.D.)	Vapor (in.)	Liquid (in.)	Vapor (in.)	Liquid (in.)
1/2	1/4	1/8	1/16	1/8	1/8
5/8	3/8	1/8	1/16	1/16	1/8



# GENERAL INSTALLATION GUIDELINES

## Piping Preparation / Piping Materials and Handling

### Tightening the Flare Nuts

Table 15: Tightening Torque for Flare Nuts.

Pipe size (Inches O.D.)	Tightening torque (ft-lbs)	Width of the flare (A [inches])
1/4Ø	13.9 - 18	1/8
3/8Ø	24.5 - 30.3	1/8
1/2Ø	39.7 - 47.7	1/8
5/8Ø	45.5 - 59.2	1/16

1. When connecting the flare nuts, coat the flare (inside and outside) with polyvinyl ether (PVE) refrigeration oil only.
2. Initially hand tighten the flare nuts using three (3) or four (4) turns.
3. To finish tightening the flare nuts, use both a torque wrench and a backup wrench.
4. After all the piping has been connected and the caps have been tightened, check for refrigerant gas leaks.

### Note:

⚠ Do not use polyolyester (POE) or any other type of mineral oil as a thread lubricant. These lubricants are not compatible with PVE oil used in this system and will create oil sludge leading to equipment damage and system malfunction.

### Loosening the Flare Nuts

Always use two (2) wrenches to loosen the flare nuts.

## Piping Materials and Handling

Pipes used for the refrigerant piping system must include the specified thickness, and the interior must be clean.

While handling and storing, do not bend or damage the pipes, and take care not to contaminate the interior with dust, moisture, etc. See Table 16 for care of piping.

Figure 32: Keep Piping Capped While Storing

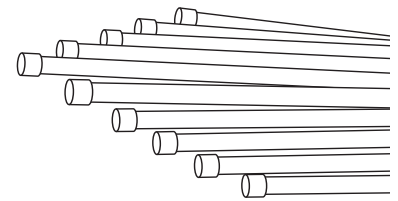
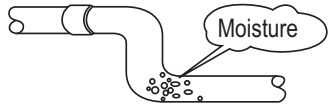

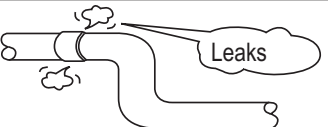

Table 16: Three Principles of Refrigerant Piping

	Dry	Clean	Airtight
Principles	No moisture should be inside the piping.	No dust should be inside the piping.	No leaks should occur.
			
Problems Caused	<ul style="list-style-type: none"> <li>- Significant hydrolysis of refrigerant oil.</li> <li>- Refrigerant oil degradation.</li> <li>- Poor insulation of the compressor.</li> <li>- System does not operate properly.</li> <li>- EEVs, capillary tubes are clogged.</li> </ul>	<ul style="list-style-type: none"> <li>- Refrigerant oil degradation.</li> <li>- Poor insulation of the compressor.</li> <li>- System does not operate properly.</li> <li>- EEVs and capillary tubes become clogged.</li> </ul>	<ul style="list-style-type: none"> <li>- Refrigerant gas leaks / shortages.</li> <li>- Refrigerant oil degradation.</li> <li>- Poor insulation of the compressor.</li> <li>- System does not operate properly.</li> </ul>
Solutions	<ul style="list-style-type: none"> <li>- Remove moisture from the piping.</li> <li>- Piping ends should remain capped until connections are complete.</li> <li>- Do not install piping on a rainy day.</li> <li>- Connect piping properly at the unit's side.</li> <li>- Remove caps only after the piping is cut, the burrs are removed, and after passing the piping through the walls.</li> <li>- Evacuate system to a minimum of 500 microns and insure the vacuum holds at that level for 24 hours</li> </ul>	<ul style="list-style-type: none"> <li>- Remove dust from the piping.</li> <li>- Piping ends should remain capped until connections are complete.</li> <li>- Connect piping properly at the side of the unit.</li> <li>- Remove caps only after the piping is cut and burrs are removed.</li> <li>- Retain the cap on the piping when passing it through walls, etc.</li> </ul>	<ul style="list-style-type: none"> <li>- Test system for air tightness.</li> <li>- Perform brazing procedures that comply with all applicable standards.</li> <li>- Perform flaring procedures that comply with all applicable standards.</li> <li>- Perform flanging procedures that comply with all applicable standards.</li> <li>- Ensure that refrigerant lines are pressure tested to 550 psig.</li> </ul>



# GENERAL INSTALLATION GUIDELINES

## Piping Materials and Handling

### Brazing Practices

**Note:**

Keep the piping system free of contaminants and debris such as copper burrs, slag, or carbon dust during installation. Contaminants can result in mechanical failure of the system.

Figure 33: Refrigerant Pipe Brazing.

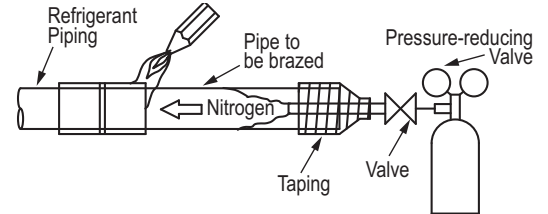

All joints are brazed in the field. Single Zone refrigeration system components contain very small capillary tubes, small orifices, electronic expansion valves, oil separators, and heat exchangers that can easily become blocked. Proper system operation depends on the installer using best practices and utmost care while assembling the piping system.

- While brazing, use a dry nitrogen purge operating at a minimum pressure of three (3) psig and maintain a steady flow.
- Blow clean all pipe sections with dry nitrogen prior to assembly.
- Use a tubing cutter, do not use a saw to cut pipe. De-burr and clean all cuts before assembly.
- Store pipe stock in a dry place. Keep pipe capped and clean.
- Use adapters to assemble different sizes of pipe.
- ⚠ Do not use flux, soft solder, or anti-oxidant agents.
- Use a 15% silver phosphorous copper brazing alloy to avoid overheating and produce good flow.
- Protect isolation valves, electronic expansion valves, and other heat-sensitive control components from excessive heat with a wet rag or a heat barrier spray product.

### Refrigerant Piping System Insulation

All refrigerant piping from the outdoor unit to the indoor unit must be insulated correctly for safety and usage. Refrigerant piping, service valves, and elbows must be properly and completely insulated using closed cell pipe insulation (up to the indoor unit piping connections). To prevent heat loss / heat gain through the refrigerant piping, all refrigerant piping including liquid lines and vapor lines shall be insulated separately. Insulation shall be a minimum 1/2" thick, and thickness may need to be increased based on ambient conditions and local codes.

Inside the outdoor unit, maximum pipe temperature is 248°F and minimum pipe temperature is -40°F. For field insulation of refrigerant piping between outdoor units and indoor units, consider the following pipe temperature ranges for an operating heat pump system:

- Heating mode refrigerant temperature ranges:    Liquid 75-118°F; High Pressure Vapor    95-220°F
- Cooling mode refrigerant temperature ranges:    Liquid 75-118°F; Low Pressure Vapor        40-90°F

# GENERAL INSTALLATION GUIDELINES

## Piping Materials and Handling

### Selecting Field-Supplied Copper Tubing

Copper is the only approved refrigerant pipe material for use with Single Zone systems products, and LG recommends seamless phosphorous deoxidized ACR type copper pipe, hard-drawn rigid type “K” or “L”, or annealed-tempered, copper pipe.

- Drawn temper (rigid) ACR copper tubing is available in sizes 3/8 through 2-1/8 inches (ASTM B 280, clean, dry, and capped).
- Annealed temper (soft) ACR copper tubing is available in sizes 1/4 through 2-1/8 inches (ASTM B 280, clean, dry, and capped).

**Note:**

Tube wall thickness should meet local code requirements and be approved for an operating pressure of 551 psi. If local code does not specify wall thickness, LG suggests using tube thickness per table below. When bending tubing, try to keep the number of bends to a minimum, and use the largest radii possible to reduce the equivalent length of installed pipe; also, bending radii greater than ten (10) pipe diameters can minimize pressure drop. Be sure no traps or sags are present when rolling out soft copper tubing coils.

Table 17: ACR Copper Tubing Material

Type	Seamless Phosphorous Deoxidized
Class	UNS C12200 DHP
Straight Lengths	H58 Temper
Coils	O60 Temper

Table 18: Piping Tube Thicknesses

OD (in)	1/4	3/8	1/2	5/8	3/4	7/8	1-1/8	1-3/8	1-5/8
Material	Rigid Type “K” or “L” and Soft ACR Acceptable			Rigid Type “K” or “L” Only					
Min. Bend Radius (in)	.563	.9375	1.5	2.25	3.0	3.0	3.5	4.0	4.5
Min. Wall Thickness (in)	.03	.03	.035	.040	.042	.045	.050	.050	.050

Table 19: ACR Copper Tubing Dimensions and Physical Characteristics<sup>1-4</sup>

Nominal Pipe Outside Diameter (in)	Actual Outside Diameter (in)	Drawn Temper			Annealed Temper		
		Nominal Wall Thickness (in)	Weight (lb/ft)	Cubic ft per Linear ft	Nominal Wall Thickness (in)	Weight (lb/ft)	Cubic ft per Linear ft
1/4	0.250	--	--	--	0.030	0.081	.00020
3/8	0.375	0.030	0.126	.00054	0.032	0.134	.00053
1/2	0.500	0.035	0.198	.00101	0.032	0.182	.00103
5/8	0.625	0.040	0.285	.00162	0.035	0.251	.00168
3/4	0.750	0.042	0.362	.00242	0.042	0.362	.00242
7/8	0.875	0.045	0.455	.00336	0.045	0.455	.00336
1-1/8	1.125	0.050	0.655	.00573	0.050	0.655	.00573

<sup>1</sup>All dimensions provided are in accordance with ASTM B280 – Standard.

<sup>2</sup>Design pressure = 551 psig.

<sup>3</sup>ACR Tubing is available as hard drawn or annealed (soft) and are suitable for use with R410A refrigerant.

<sup>4</sup>The Copper Tube Handbook, 2010, Copper Development Association Inc., 260 Madison Avenue, New York, NY 10016.

**Note:**

- Commercially available piping often contains dust and other materials. Always blow it clean with a dry inert gas.
- Prevent dust, water or other contaminants from entering the piping during installation. Contaminants can cause mechanical failure.

# GENERAL INSTALLATION GUIDELINES

## Piping Materials and Handling

### No Pipe Size Substitutions

#### Note:

Use only the pipe size recommended by this installation manual. Using a different size is prohibited and may result in a system malfunction or failure to work at all.

### Obstacles

When an obstacle, such as an I-beam or concrete T, is in the path of the planned refrigerant pipe run, it is best practice to route the pipe over the obstacle. If adequate space is not available to route the insulated pipe over the obstacle, then route the pipe under the obstacle. In either case, it is imperative the length of the horizontal section of pipe above or below the obstacle be a minimum of three (3) times the longest vertical rise (or fall) at either end of the segment.

### Copper Expansion and Contraction

Under normal operating conditions, the vapor pipe temperature of a Duct Free System can vary as much as 280°F. With this large variance in pipe temperature, the designer must consider pipe expansion and contraction to avoid pipe and fitting fatigue failures.

Refrigerant pipe along with the insulation jacket form a cohesive unit that expands and contracts together. During system operation, thermal heat transfer occurs between the pipe and the surrounding insulation.

If the pipe is mounted in free air space, no natural restriction to movement is present if mounting clamps are properly spaced and installed. When the refrigerant pipe is mounted underground in a utility duct stacked among other pipes, natural restriction to linear movement is present. In extreme cases, the restrictive force of surface friction between insulating jackets could become so great that natural expansion ceases and the pipe is “fixed” in place. In this situation, opposing force caused by change in refrigerant fluid/vapor temperature can lead to pipe/fitting stress failure.

The refrigerant pipe support system must be engineered to allow free expansion to occur. When a segment of pipe is mounted between two fixed points, provisions must be provided to allow pipe expansion to naturally occur. The most common method is the inclusion of expansion Loop or U-bends. Each segment of pipe has a natural fixed point where no movement occurs. This fixed point is located at the center point of the segment assuming the entire pipe is insulated in a similar fashion. The natural fixed point of the pipe segment is typically where the expansion Loop or U-bend should be.

Linear pipe expansion can be calculated using the following formula:  
 $LE = C \times L \times (T_r - T_a) \times 12$

LE	=	Anticipated linear tubing expansion (in.)
C	=	Constant (For copper = $9.2 \times 10^{-6}$ in./in.°F)
L	=	Length of pipe (ft.)
$T_r$	=	Refrigerant pipe temperature (°F)
$T_a$	=	Ambient air temperature (°F)
12	=	Inches to feet conversion (12 in./ft.)

Figure 34: Installing Piping Above and Below an Obstacle.

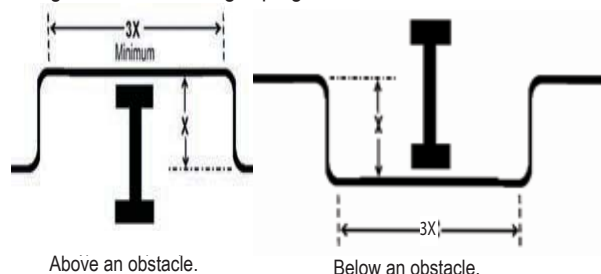

1. From Table 20 find the row corresponding with the actual length of the straight pipe segment.
2. Estimate the minimum and maximum temperature of the pipe. In the column showing the minimum pipe temperature, look up the anticipated expansion distance. Do the same for the maximum pipe temperature.
3. Calculate the difference in the two expansion distance values. The result will be the anticipated change in pipe length.

#### Example:

A system is installed and the design shows that there is a 100 foot straight segment of tubing between an indoor unit and the outdoor unit. In heating, this pipe transports hot gas vapor to the indoor units at 120 °F. In cooling, the same tube is a suction line returning refrigerant vapor to the outdoor unit at 40 °F. Look up the copper tubing expansion at each temperature and calculate the difference.

#### Vapor Line

Transporting Hot Vapor: 100 ft. pipe at 120 °F = 1.40 in.  
 Transporting Suction Vapor: 100 ft. pipe at 40 °F = 0.40 in.  
 Anticipated Change in Length: 1.40 in. – 0.40 in. = 1.00 in.

#### Liquid Line

The liquid temperature remains relatively the same temperature; only the direction of flow will reverse. Therefore, no significant change in length of the liquid line is anticipated.

When creating an expansion joint, the joint height should be a minimum of two times the joint width. Although different types of expansion arrangements are available, the data for correctly sizing an Expansion Loop is provided in Table 21. Use soft copper with long radius bends on longer runs or long radius elbows for shorter pipe segments. Using the anticipated linear expansion (LE) distance calculated, look up the Expansion Loop or U-bend minimum design dimensions. If other types of expansion joints are chosen, design per ASTM B-88 Standards.

# GENERAL INSTALLATION GUIDELINES

## Piping Materials and Handling

See table below for precalculated anticipated expansion for various pipe sizes and lengths of refrigerant tubing.

To find the anticipated expansion value:

1. From the table below, find the row corresponding with the actual feet of the straight pipe segment.
2. Estimate the minimum and maximum temperature of the pipe.
3. In the column showing the minimum pipe temperature, look up the anticipated expansion distance corresponding to the segment length. Do the same for the maximum pipe temperature.
4. Calculate the difference in the two expansion distance values. The result will be the change in pipe length.

Table 20: Linear Thermal Expansion of Copper Tubing in Inches

Pipe Length <sup>1</sup>	Fluid Temperature °F																			
	35°	40°	45°	50°	55°	60°	65°	70°	75°	80°	85°	90°	95°	100°	105°	110°	115°	120°	125°	130°
10	0.04	0.04	0.05	0.06	0.06	0.07	0.08	0.08	0.09	0.09	0.10	0.10	0.11	0.11	0.11	0.12	0.13	0.14	0.15	0.15
20	0.08	0.08	0.10	0.12	0.13	0.14	0.15	0.16	0.17	0.18	0.19	0.20	0.21	0.22	0.22	0.23	0.26	0.28	0.29	0.30
30	0.12	0.12	0.15	0.18	0.20	0.21	0.23	0.24	0.26	0.27	0.29	0.30	0.32	0.33	0.32	0.35	0.39	0.42	0.44	0.45
40	0.16	0.16	0.20	0.24	0.26	0.28	0.30	0.32	0.34	0.36	0.38	0.40	0.42	0.44	0.43	0.46	0.52	0.56	0.58	0.60
50	0.20	0.20	0.25	0.30	0.33	0.35	0.38	0.40	0.43	0.45	0.48	0.50	0.53	0.55	0.54	0.58	0.65	0.70	0.73	0.75
60	0.24	0.24	0.30	0.36	0.39	0.42	0.45	0.48	0.51	0.54	0.57	0.60	0.63	0.66	0.65	0.69	0.78	0.84	0.87	0.90

<sup>1</sup>Pipe length baseline temperature = 0°F. "Expansion of Carbon, Copper and Stainless Steel Pipe," *The Engineers' Toolbox*, www.engineeringtoolbox.com.

Figure 35: Coiled Expansion Loops and Offsets

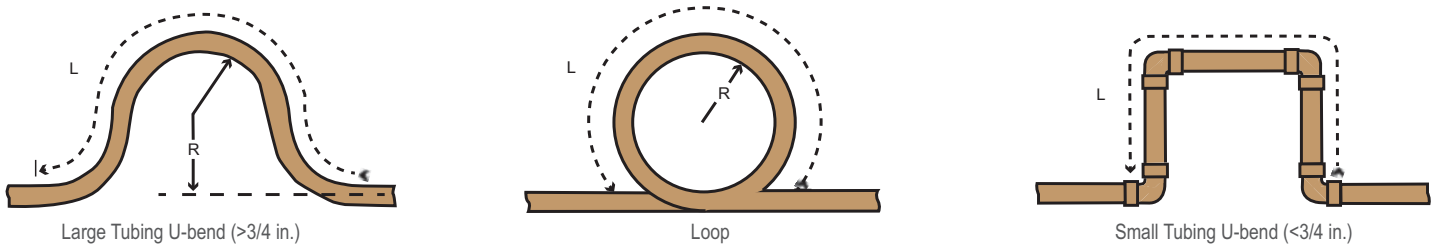

Table 21: Radii of Coiled Expansion Loops and Developed Lengths of Expansion Offsets

Anticipated Linear Expansion (LE) (inches)		Nominal Tube Size (OD) inches			
		1/4	3/8	1/2	3/4
1/2	R <sup>1</sup>	6	7	8	9
	L <sup>2</sup>	38	44	50	59
1	R <sup>1</sup>	9	10	11	13
	L <sup>2</sup>	54	63	70	83
1-1/2	R <sup>1</sup>	11	12	14	16
	L <sup>2</sup>	66	77	86	101
2	R <sup>1</sup>	12	14	16	19
	L <sup>2</sup>	77	89	99	117
2-1/2	R <sup>1</sup>	14	16	18	21
	L <sup>2</sup>	86	99	111	131
3	R <sup>1</sup>	15	17	19	23
	L <sup>2</sup>	94	109	122	143
3-1/2	R <sup>1</sup>	16	19	21	25
	L <sup>2</sup>	102	117	131	155
4	R <sup>1</sup>	17	20	22	26
	L <sup>2</sup>	109	126	140	166

# GENERAL INSTALLATION GUIDELINES

## Piping Materials and Handling

### Pipe Bends

When bending soft copper, use long radius bends. Refer to the “Radii of Coiled Expansion Loops and Developed Lengths of Expansion Offsets” table for minimum radius specifications, as shown on previous page.

### In-line Refrigeration Components



Components such as oil traps, solenoid valves, filter-dryers, sight glasses, tee fittings, and other after-market accessories are not permitted on the refrigerant piping system between the outdoor unit and the indoor unit.

Single Zone systems are provided with redundant systems that assure oil is properly returned to the compressor. Sight-glasses and solenoid valves may cause vapor to form in the liquid stream.

#### Note:

Over time, dryers may deteriorate and introduce debris into the system. The designer and installer should verify the refrigerant piping system is free of traps, sagging pipes, sight glasses, filter dryers, etc.

### Using Elbows

Field-supplied elbows are allowed as long as they are designed for use with R410A refrigerant. The designer, however, should be cautious with the quantity and size of fittings used, and must account for the additional pressure losses in equivalent pipe length calculation. The equivalent pipe length of each elbow must be added to each pipe segment (Table 22).

Table 22: Equivalent Piping Length for Piping Components

Component	Size (Inches)				
Elbow (ft.)	1/4	3/8	1/2	5/8	3/4
	0.5	0.6	0.7	0.8	1.2

### Pipe Supports

#### Note:

A properly installed pipe system should be adequately supported to avoid pipe sagging. Sagging pipes become oil traps that lead to equipment malfunction.

Pipe supports should never touch the pipe wall; supports shall be installed outside (around) the primary pipe insulation jacket (see Figure 36). Insulate the pipe first because pipe supports shall be installed outside (around) the primary pipe insulation jacket. Clevis hangers should be used with shields between the hangers and insulation. Field provided pipe supports should be designed to meet local codes. If allowed by code, use fiber straps or split-ring hangers suspended from the ceiling on all-thread rods (fiber straps or split ring hangers can be used as long as they do not compress the pipe insulation). Place a second layer of insulation over the pipe insulation jacket to prevent chafing and compression of the primary insulation within the confines of the support pipe clamp.

Figure 36: Pipe Hanger Details

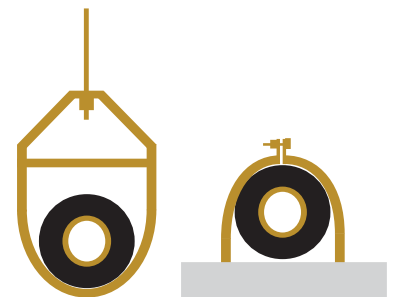

# GENERAL INSTALLATION GUIDELINES

## Piping Support, Elbow Usage

### Pipe Supports, continued.

A properly installed pipe system will have sufficient supports to avoid pipes from sagging during the life of the system. As necessary, place supports closer for segments where potential sagging could occur. Maximum spacing of pipe supports shall meet local codes.

If local codes do not specify pipe support spacing, pipe shall be supported:

- Maximum of five feet (5') on center for straight segments of pipe up to 3/4" outside diameter size.
- Maximum of six feet (6') on center for pipe up to one inch (1") outside diameter size.
- Maximum of eight feet (8') on center for pipe up to two inches (2") outside diameter size.

Wherever the pipe changes direction, place pipe clamps within twelve (12) inches on one side and within twelve to nineteen (12 to 19) inches of the bend on the other side as shown in Figure 37.

Figure 37: Typical Pipe Support Location—Change in Pipe Direction

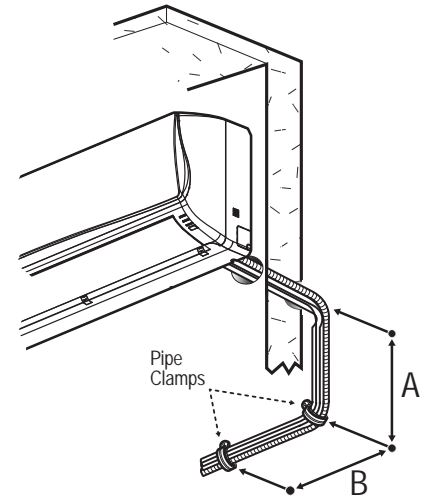

### Pipe Sleeves at Penetrations

LG requires that all pipe penetrations through walls, floors, and pipes buried underground be properly insulated and routed through an appropriate wall sleeve of sufficient size to prevent compression of refrigerant pipe insulation and free movement of the pipe within the sleeve (Figure 38). Underground refrigerant pipe shall be routed inside a protective sleeve to prevent insulation deterioration. Refer to Figure 39.

Figure 38: Pipe Sleeve Options.

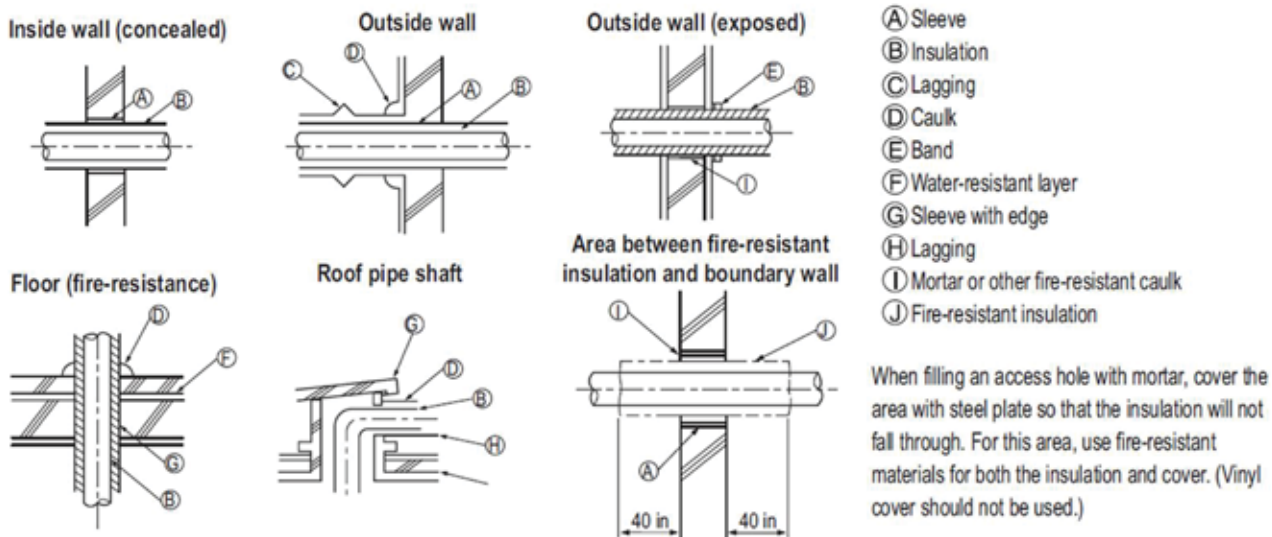

### Note

Diameter of penetrations shall be determined by pipe diameter plus the thickness of the insulation.



# GENERAL INSTALLATION GUIDELINES

## Refrigerant Piping System Layout

### Underground Refrigerant Piping

Refrigerant pipe installed underground should be routed inside a vapor tight protective sleeve to prevent insulation deterioration and water infiltration. Refrigerant pipe installed inside underground casing must be continuous without any joints. Underground refrigerant pipe must be located at a level below the frost line.

Table 23: Utility Conduit Sizes.

Liquid Pipe <sup>1</sup>	Vapor Pipe <sup>1</sup>		
	3/8 (1-1/8 <sup>2,3</sup> )	1/2 (2.0 <sup>2,4</sup> )	5/8 (2-1/8 <sup>2,4</sup> )
1/4 (1.0) <sup>3</sup>	4	4	4
3/8 (1-1/8) <sup>3</sup>	4	4	4

<sup>1</sup>OD pipe diameter in inches; Values in parenthesis () indicate OD of pipe with insulation jacket.

<sup>2</sup>Diameter of pipe with insulation. Thickness of pipe insulation is typical. Actual required thickness may vary based on surrounding ambient conditions and should be calculated and specified by the design engineer.

<sup>3</sup>Insulation thickness (value in parenthesis) = 3/8 inch.

<sup>4</sup>Insulation thickness (value in parenthesis) = 1 inch.

Figure 39: Typical Arrangement of Refrigerant Pipe and Cable(s) in a Utility Conduit.

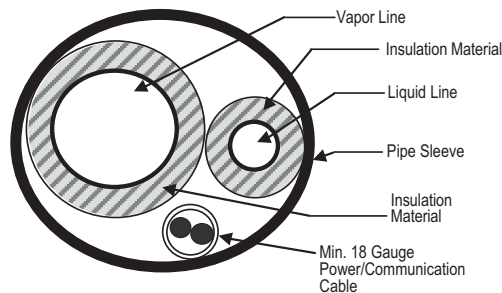

Table 24: Heat Pump Unit Refrigerant Pipe Connections (All Brazed Type)

Model	Liquid Conn. (inches)	Vapor Conn. (inches)
LSU091HSV3, LSU121HSV3	1/4	3/8
LSU181HSV3, LSU240HSV3	3/8	5/8
LSU307HV3, LSU360HV3	3/8	5/8
LSU240HLV, LSU300HLV, LSU360HLV	3/8	5/8
LSU090HEV, LSU120HEV, LSU090HEV1, LSU120HEV1, LSU090HXV, LSU120HXV	1/4	3/8
LSU180HEV, LSU180HEV1	1/4	1/2
LSU240HEV, LSU240HEV1	1/4	5/8

# REFRIGERANT PIPING CONNECTIONS

## Refrigerant Piping System Limitations

### Connection Limitations

Single zone systems consist of one outdoor unit and one indoor unit. One of the most critical elements of a single zone system is the refrigerant piping. Tables 25 to 28 list pipe length limits that must be followed in the design of a Single Zone Wall Mount refrigerant pipe system. Refer to Figure 40 for maximum length and elevation of piping.

Table 25: Single Zone High Efficiency Refrigerant Piping System Limitations

Pipe Length (ELF = Equivalent Length of pipe in Feet)	Longest total equivalent piping length	LS091HSV3	LS121HSV3	LS181HSV3	LS240HSV3
		Shortest total equivalent piping length	65.6	65.6	98.4
	Distance between fittings and indoor units or outdoor units	≥20 inches	≥20 inches	≥20 inches	≥20 inches
Elevation (All Elevation Limitations are Measured in Actual Feet)	If outdoor unit is above indoor unit	32.8	32.8	49.2	49.2
	If outdoor unit is below indoor unit	32.8	32.8	49.2	49.2
Additional Refrigerant Needed (oz/ft)		0.22	0.22	0.38	0.38

Table 26: Single Zone Standard Refrigerant Piping System Limitations

Pipe Length (ELF = Equivalent Length of pipe in Feet)	Longest total equivalent piping length	LS307HV3	LS360HV3
		Shortest total equivalent piping length	98.4
	Distance between fittings and indoor units or outdoor units	≥20 inches	≥20 inches
Elevation (All Elevation Limitations are Measured in Actual Feet)	If outdoor unit is above indoor unit	49.2	49.2
	If outdoor unit is below indoor unit	49.2	49.2
Additional Refrigerant Needed (oz/ft)		0.38	0.38

Figure 40: Single Zone System Layout

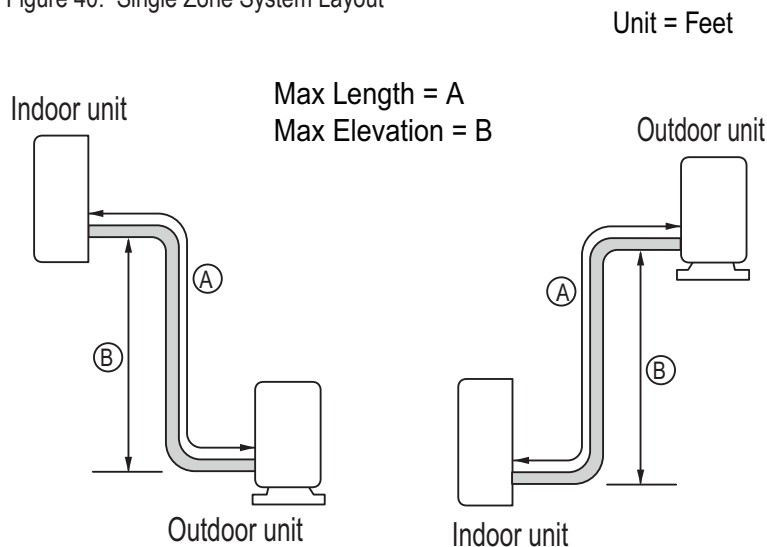

# REFRIGERANT PIPING CONNECTIONS

## Refrigerant Piping System Limitations

### Connection Limitations - Continued

Table 27: Single Zone Extended Pipe Refrigerant Piping System Limitations

Pipe Length (ELF = Equivalent Length of pipe in Feet)	Longest total equivalent piping length	LS240HLV	LS300HLV	LS360HLV
		164.0	164.0	164.0
	Shortest total equivalent piping length	9.8	9.8	9.8
	Distance between fittings and indoor units or outdoor units	≥20 inches	≥20 inches	≥20 inches
Elevation (All Elevation Limitations are Measured in Actual Feet)	If outdoor unit is above indoor unit	98.4	98.4	98.4
	If outdoor unit is below indoor unit	98.4	98.4	98.4
Additional Refrigerant Needed (oz/ft)		0.38	0.38	0.38

Table 28: Single Zone Mega (HEV and HEV1) / Mega 115V Pipe Refrigerant Piping System Limitations

Pipe Length (ELF = Equivalent Length of pipe in Feet)	Longest total equivalent piping length	LS090HEV, LS090HEV1/ LS120HEV, LS120HEV1	LS180HEV, LS180HEV1/ LS240HEV, LS240HEV1	LS090HXV/ LS120HXV
		49.2	65.6	49.2
	Shortest total equivalent piping length	9.8	9.8	9.8
	Distance between fittings and indoor or outdoor units	≥20 inches	≥20 inches	≥20 inches
Elevation (All Elevation Limitations are Measured in Actual Feet)	If outdoor unit is above indoor unit	22.9	32.8	23
	If outdoor unit is below indoor unit	22.9	32.8	23
Additional Refrigerant Needed (oz/ft)		0.22	0.33	0.22

# REFRIGERANT PIPING CONNECTIONS

## Installation Overview

### Installation

Single Zone Wall-Mounted systems are one-to-one systems. There is a direct piping connection between the outdoor unit and the indoor unit. Figure 41 illustrates the basic pipe connections between the outdoor and indoor unit. Refer back to this illustration as you proceed with pipe connections. This illustration shows the indoor unit being installed at a higher position than the outdoor unit. However, should you install the outdoor unit at a higher position than the indoor unit, the basic pipe connections should be the same.

Refer back to the tables within the "Connection Limitations" section, on the previous page, for specific length limitations in conjunction with outdoor unit and indoor unit positioning.

**Note:**

- As you proceed with the piping connections be sure to adhere to pipe support spacing lengths as shown in Figure 42 below. Refer back to "Pipe Supports" section for in-depth information regarding using elbows, clamps and pipe supporting materials.
- Always adhere to local codes regarding piping and accurate support spacing along the outdoor pipe line.

Figure 42: Pipe Support Lengths - Outdoors

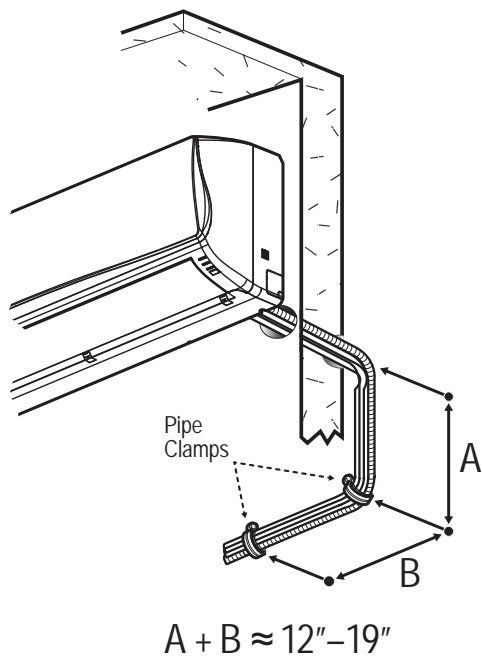
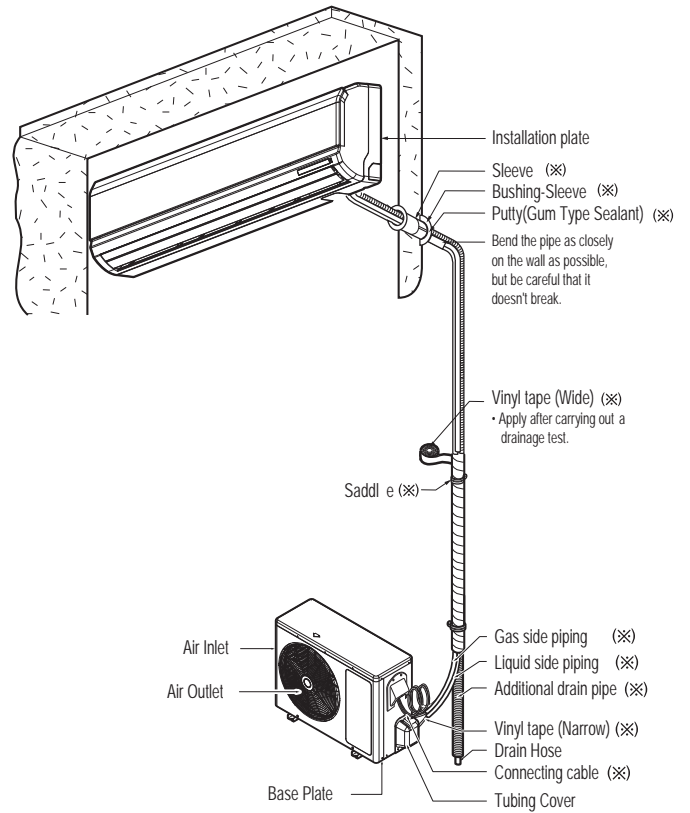

Figure 41: Installation and Piping Connection Overview

### Installation Overview



(⊗) Additional accessories/parts/tools that will be needed for installation but are not provided by LG.

# REFRIGERANT PIPING CONNECTIONS

## Directional Pipe Formation

### Pipe Bundling

See Figure 43 for proper pipe and cable bundling. Note the placement of the piping along with the necessary insulation material.

1. Be sure to wrap each pipe with proper insulation material.
2. Secure the piping by wrapping vinyl tape around the pipe.
  - Use the narrow size tape for wrapping the actual pipe.
3. You can include the drain hose within the bundled piping and wrap all of them together using the wider vinyl tape as shown in Figure 44.
- The end of the drain hose outlet must be routed above the ground.

Figure 43: Cutaway of Proper Pipe and Cable Bundling

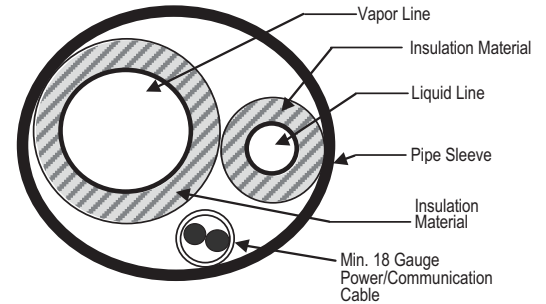

### Indoor Unit Installed Above Outdoor Unit

1. Refer to Figure 45 while following the procedures below.
2. Tape the piping, drain hose and connecting cable from down to up.
3. Secure the taped piping along the exterior wall using pipe clamps.
4. Create trap above the electrical connections cover, in order to prevent water from penetrating electrical components and wiring.

Figure 44: Bundling and Taping

### Bundling Piping

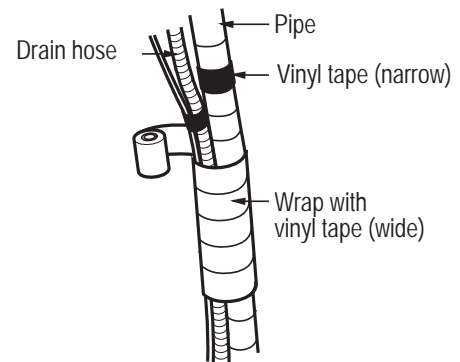

### Indoor Unit Installed Below Outdoor Unit

1. Refer to Figure 46 while following the procedures below.
2. Tape the piping, drain hose and connection cable from down to up.
3. Secure the taped piping along the exterior wall using pipe clamps.
4. Create trap above the electrical connections cover, in order to prevent water from entering the room.

Figure 45: IDU Above ODU - Piping and Trap

### Indoor Unit Installed ABOVE Outdoor Unit - Piping/Trap

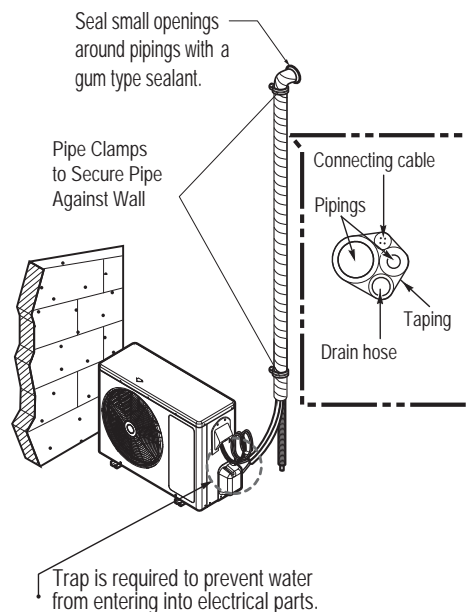
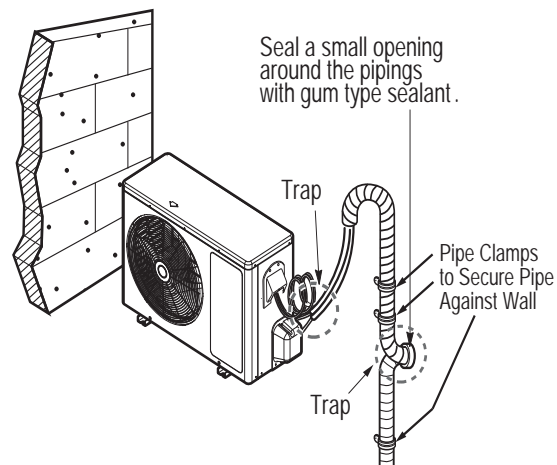

Figure 46: IDU Below ODU - Piping and Trap

### Indoor Unit Installed BELOW Outdoor Unit - Piping/Trap



# REFRIGERANT PIPING CONNECTIONS

## Drain Hose

### Indoor Unit Drain Hose Guidelines

**Note:**

Refer to the diagrams below and follow proper installation and the running of the drain hose along the pipe installation line to avoid leakage. Once drain hose is set in place, always follow with evacuation and leakage testing of all piping to be sure all piping is properly sealed. Re-check and retest as necessary.

Drain hose is routed from the indoor unit through the structure (wall) to the outdoor. It should slope at an angle where it is higher at the indoor unit and lower toward the outdoor area, thereby letting gravity push any condensation down and out. See Figure 47 for proper drainage slope. Avoid piping the drain hose as shown in Figure 48. These methods are incorrect and can cause leakage at the indoor unit site.

Figure 47: Correct Slope Angle for Drain Hose

Correct Drainage Slope

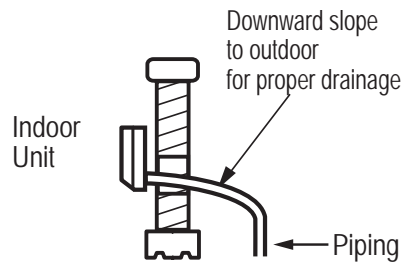
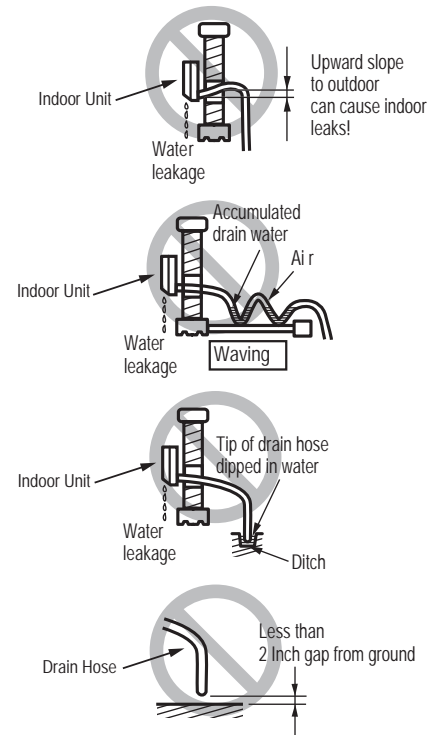

Figure 48: Correct Slope Angle for Drain Hose

Incorrect Drainage Setup



### Outdoor Unit Drain Hose Guidelines

Depending on installation site, it may be necessary to install a drain plug (factory supplied).

1. See the figures below for drain plug installation.
2. Connect a field-supplied hose to the drain connection (A). If the hose is too long, position it carefully to prevent kinks.

Table 29: Outdoor Unit Drain Connection Legend

Label	Component
A	Drain Connection
B	Drain Cap
C	Drain Washer

**Note:**

Do not use a drain hose with the outdoor unit in cold climates, otherwise the drain water may freeze and impair heating performance.

Figure 49: HSV3 and HV3 Outdoor Unit Drain Connection Components

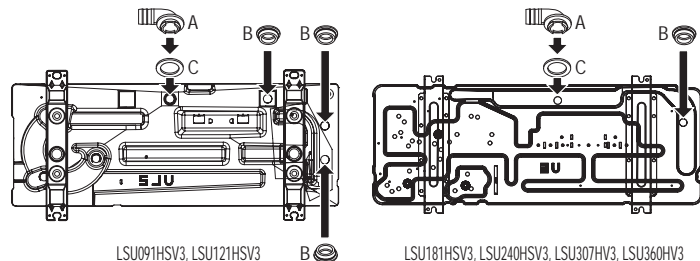

Figure 50: HXV and HLV Outdoor Unit Drain Connection Components

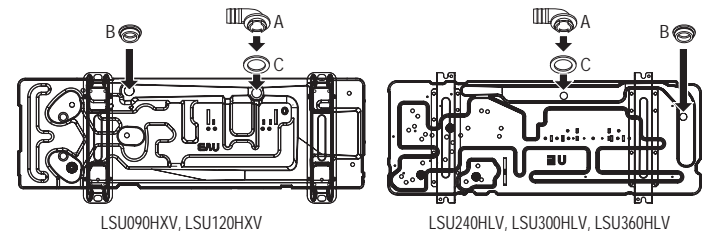
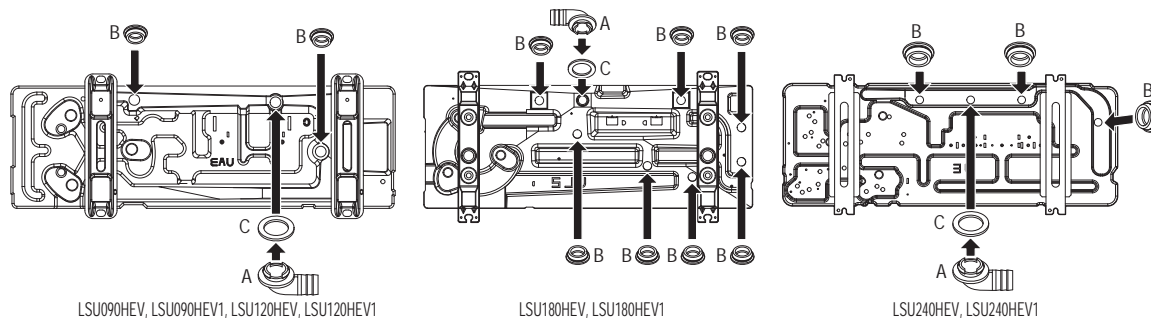

Figure 51: HEV and HEV1 Outdoor Unit Drain Connection Components.



Due to our policy of continuous product innovation, some specifications may change without notification. ©LG Electronics U.S.A., Inc., Englewood Cliffs, NJ. All rights reserved. "LG" is a registered trademark of LG Corp.





# REFRIGERANT PIPING CONNECTIONS

## Outdoor Unit Connections

### Single Zone Wall Mount Outdoor Unit Connections (HSV3, HV3, HLV)

1. Remove the tubing cover by loosening the fastening screws. See Figures 52 and 53.
2. Align the center of the refrigerant pipe and corresponding connection as shown below.
3. Refer to Figure 54 (for HSV3) and Figure 55 (for HV3, HLV) for correct liquid and gas pipe attachment onto outdoor unit.
4. Place a couple of drops of refrigerant oil on the opening rim of the flare before assembling. Ensure you do not add any contaminants. Tighten the flare nut initially by hand.
5. Finish tightening the flare nut with a torque wrench until the wrench clicks. Follow torque guidelines in Table 30. See figures for correct connection points.

Figure 52: Outdoor Unit Connection Cover Removal (HSV3)

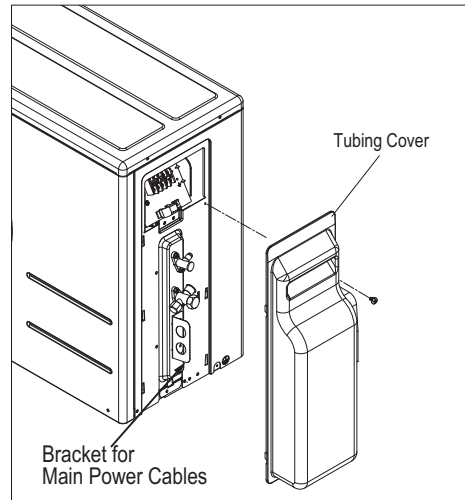

Figure 53: Outdoor Unit Connection Cover Removal (HV3, HLV)

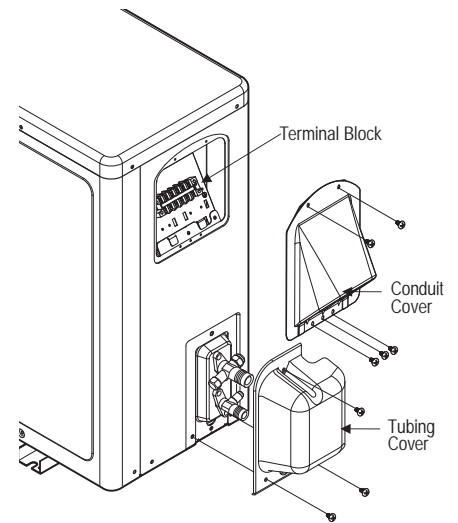

Figure 54: Outdoor Unit Piping Connection (HSV3)

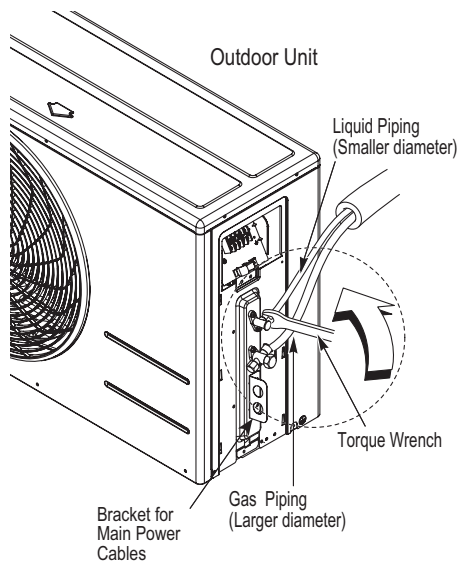

Figure 55: Outdoor Unit Piping Connection (HV3, HLV)

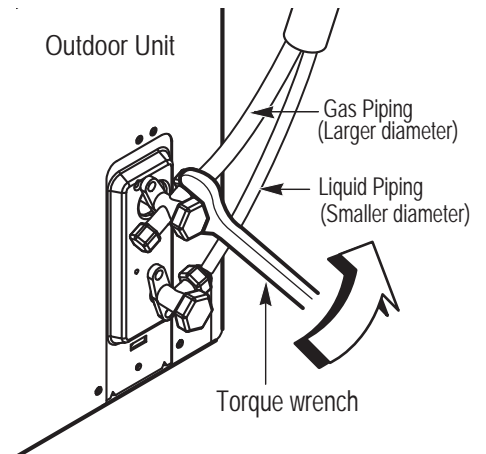
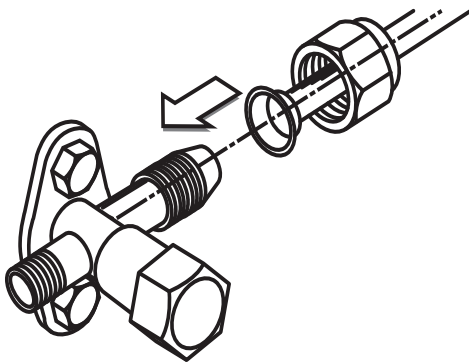

Figure 56: Pipe Attachment



#### Note:

When tightening the flare nut with a torque wrench, ensure the direction for tightening follows the arrow on the wrench.

Table 30: Torque Wrench Tightening

Outside Diameter (inches)	Torque (lbs-ft)
1/4	13-18
3/8	24.6-30.4
1/2	39.8-47.7
5/8	45.6-59.3

#### Note:

⊘ Do not thread liquid or gas piping through bracket used to hold main power cables (for HSV3 model).

# REFRIGERANT PIPING CONNECTIONS

## Outdoor Unit Connections

### Single Zone Wall Mount Outdoor Unit Connections (090HEV, 090HEV1, 120HEV, 120HEV1, 240HEV, 240HEV1, 090HXV, 120HXV)

1. Remove the tubing cover by loosening the fastening screws (Figures 57 to 59).
2. Align the center of the refrigerant pipe and corresponding connection as shown in Figure 60.
3. Refer to Figures 61 to 63 for correct liquid and gas pipe attachment onto outdoor unit.
4. Place a couple of drops of refrigerant oil on the opening rim of the flare before assembling. Ensure you do not add any contaminants. Tighten the flare nut initially by hand.
5. Finish tightening the flare nut with a torque wrench until the wrench clicks. Follow the guidelines as outlined in Table 31 for the amount of torque to use.

Figure 57: LSU90-120HEV/HEV1, LSU90-120HXV Outdoor Unit Connection Cover Removal

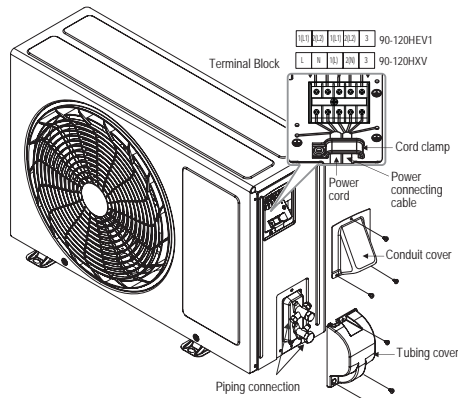

Figure 58: LSU180HEV/HEV1 Outdoor Unit Connection Cover Removal

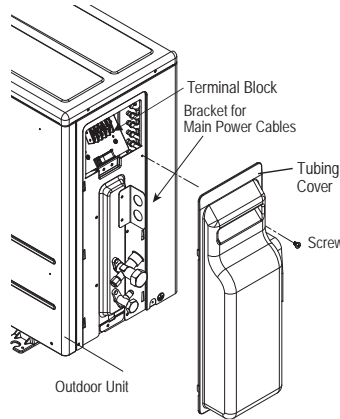

Figure 59: LSU240HEV/HEV1 Outdoor Unit Connection Cover Removal

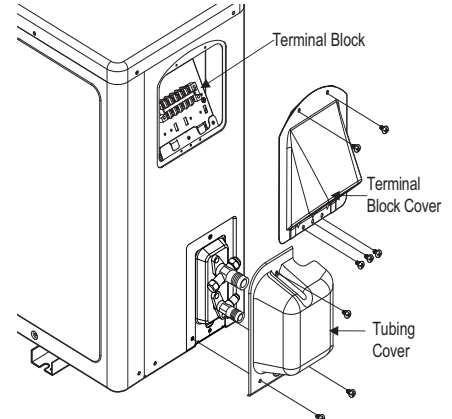
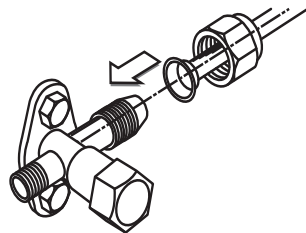

Figure 60: Pipe Attachment.



**Note:**

- Do not thread liquid or gas piping through bracket used to hold main power cables.
- When tightening the flare nut with torque wrench, ensure the direction for tightening follows the arrow on the wrench.

Table 31: Torque Wrench Tightening

Outside Diameter (Inches)	Torque (Lbs.-ft)
1/4	13-18
3/8	24.6-30.4
1/2	39.8-47.7
5/8	45.6-59.3
3/4	71.6-87.5

Figure 61: LSU90-120HEV/HEV1, LSU90-120HXV Outdoor Unit Piping Connection.

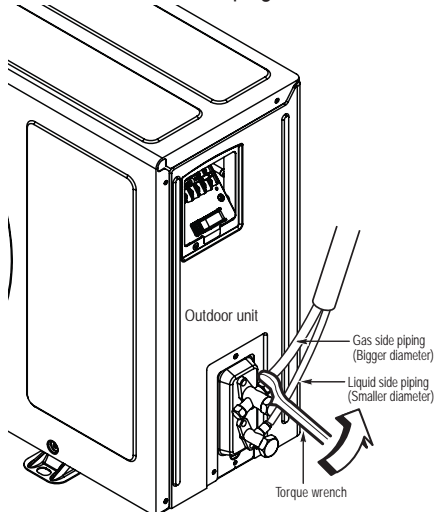

Figure 62: LSU180HEV/HEV1 Outdoor Unit Piping Connection.

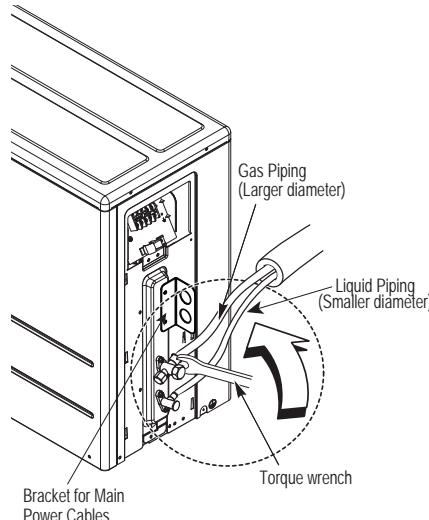
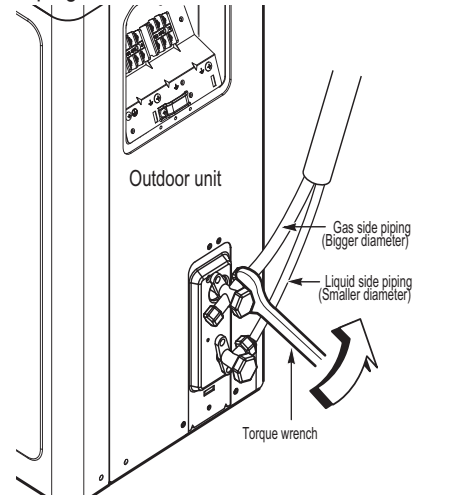

Figure 63: LSU240HEV/HEV1 Outdoor Unit Piping Connection.



# REFRIGERANT PIPING CONNECTIONS

## Indoor Unit Connections

### Piping to Indoor Unit (HSV3, HLV, HXV, HEV, HEV1)

Follow the steps below and refer to the illustrations on this page to connect piping to the Single Zone indoor unit. To see specific bundling of piping and drain hose, see Section, “*Bundling and Cutting Line*” on page 45. Also, refer back to “*Drain Hose Guidelines*” section for proper drainage slope during piping procedure.

1. Pull the screw cap(s) at the bottom of the indoor unit (Figure 64).
2. Unscrew the two (2) or three (3) screws (depending on the indoor unit model) at the bottom of the chassis cover.
3. Remove the chassis cover, being careful not to scratch the main horizontal vane.
4. From the rear of the indoor unit, pull the tubing holder away from the unit as shown in Figure 65.
5. Remove the pipe port cover.
6. Position the tubing by unfolding the tubing and bending the tubing slowly downward first, as shown below.

Figure 64: Removing Chassis Cover from Indoor Unit.

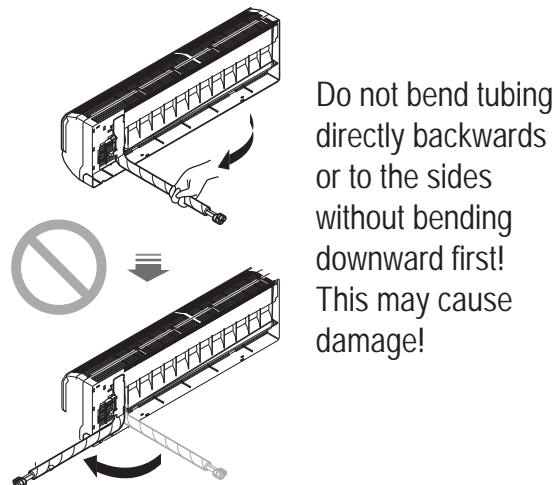
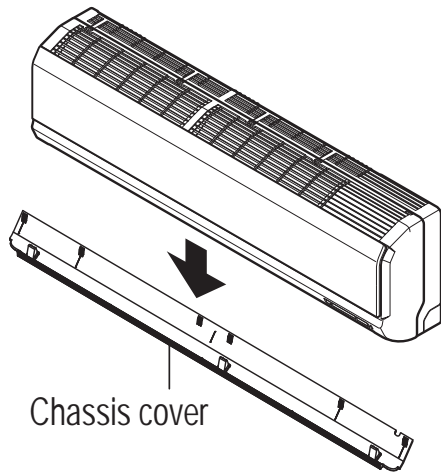
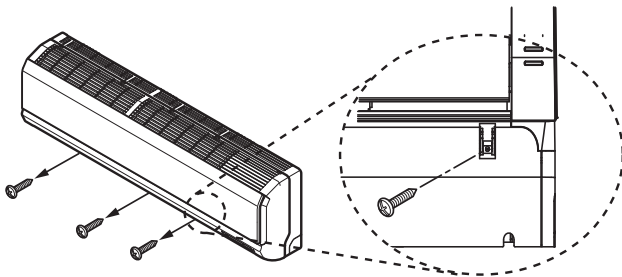

**Note:**  
Bending the tubing directly left or right, without bending downward first, may cause damage.

Figure 65: Bending Pipe Tubing at Rear of Indoor Unit.

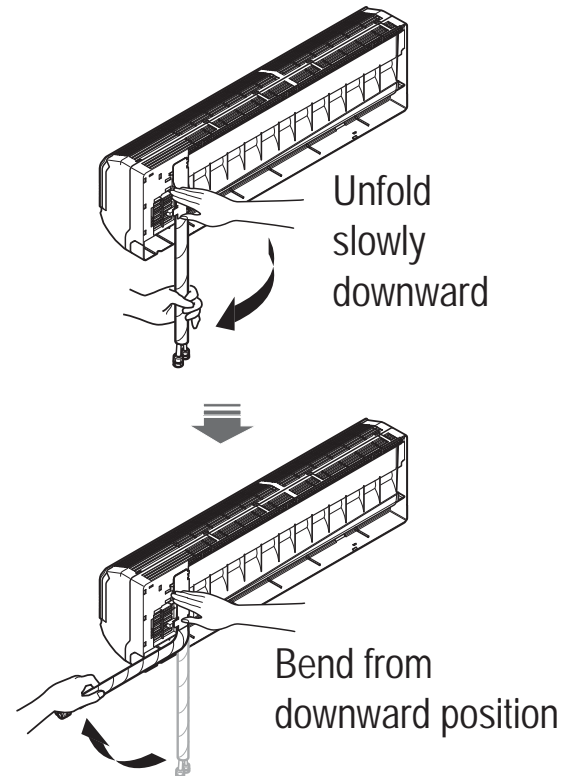

# REFRIGERANT PIPING CONNECTIONS

## Indoor Unit Connections - Conduit Bracket Placement

### Piping to Indoor Unit - Conduit Bracket Placement (HV3, HEV, HEV1)

1. Follow steps 1 through 6 on the previous page to connect piping to the rear of the indoor unit.

Most HV3, HEV, HEV1 and HXV single-zone models require an additional conduit "bracket/nut" to be installed at the rear of the indoor unit to secure an elbow conduit. Follow the steps below for correct placement for your unit model.

2. Set the conduit by using the bracket and "D" screws from the accessory kit. This must be done prior to permanent placement of the piping to the rear of the unit, otherwise you won't be able to reach the conduit once piping and drain hose are in place and anchored.

- For specific bracket placement, see each figure relating to the specific single-zone model.

Figure 70: Elbow Conduit



**Note:**

Pay attention to bracket placement on each single zone units. Your model might be slightly different from figure shown in this manual.

For specific bundling (taping) techniques of the Pipe and Drain Hose, see Section, "Bundling and Cutting Line" on page 45.

Figure 66: Installing Bracket for Conduit (HV3)

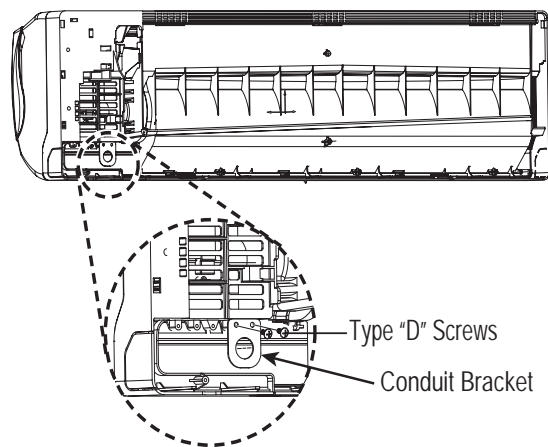

Figure 68: Installing Bracket for Conduit (120HEV)

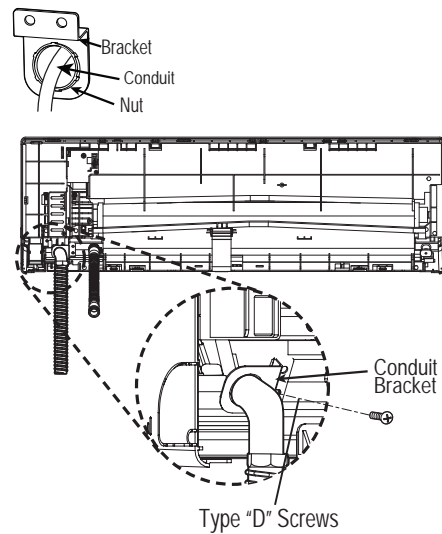

Figure 67: Installing Bracket for Conduit (090HEV, 090HEV1)

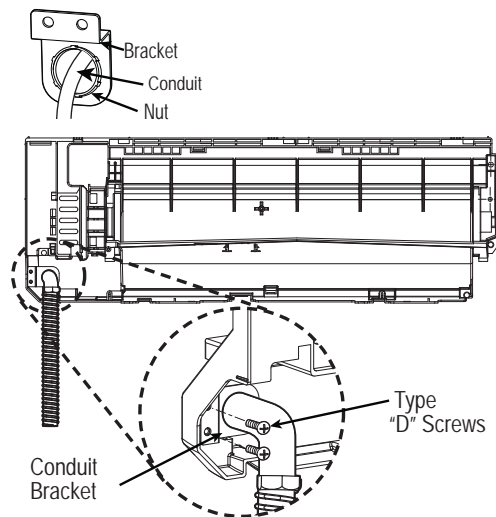
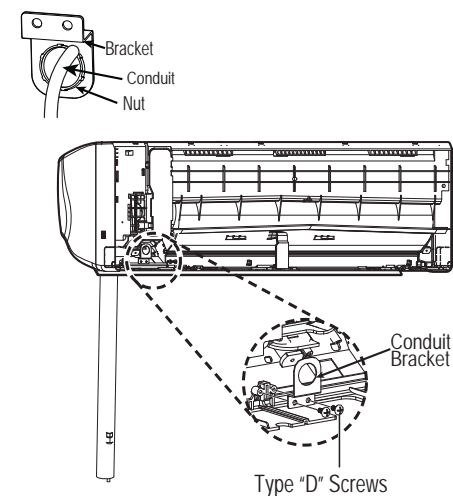

Figure 69: Installing Bracket for Conduit (180HEV, 180HEV1, 240HEV, 240HEV1)



# REFRIGERANT PIPING CONNECTIONS

## Bundling and Cutting Line

Piping and cabling must be insulated and bundled together correctly for safety and usage. Follow proper methods and procedures as outlined here and on the next pages to ensure installation and piping are correctly installed.

As shown in Figure 71, the indoor unit pipe are fully encased in insulation material.

1. Bind together the two pipes, using vinyl tape. Make sure there are no gaps during the binding.
2. Be sure the tube cutting line is placed upward (Figure 72).
3. Verify that rear piping house section is wrapped with vinyl tape.
  - Use a narrow type of vinyl tape for this step.
4. Continue to wrap the Indoor unit pipe as connected to the outdoor connection pipe as shown in Figure 73.

Figure 72: Correct Cutting Line Placement

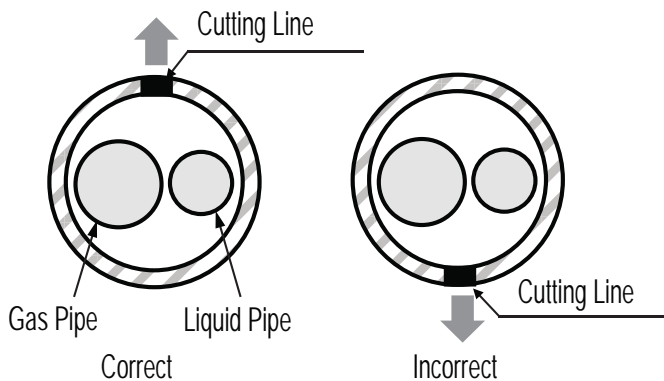

5. Using a wider vinyl tape, bundle the piping and drain hose together (Figure 74).
  - Tape should be sufficient to cover the piping in order to fit into the rear piping housing area at the back of the indoor unit (Figure 75).

Figure 75: Bundling and Placement at Rear of IDU

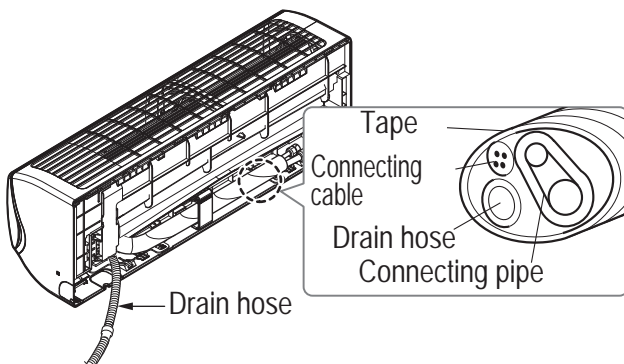

Figure 71: Piping with Insulation Material

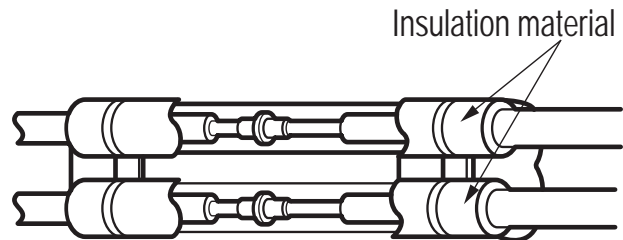

Figure 73: Wrapping Connection Pipe to Indoor Unit's Pipe

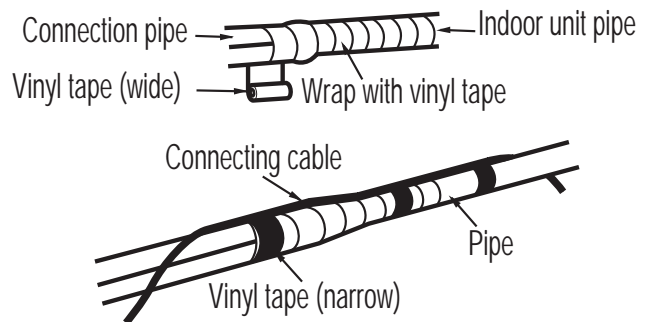
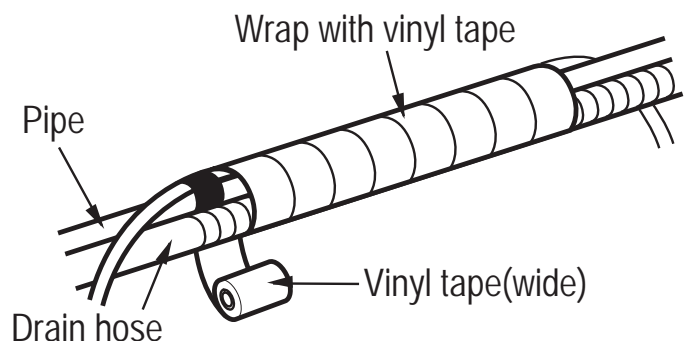

Figure 74: Bundling Pipe and Drain Hose, Rear of IDU





# REFRIGERANT PIPING CONNECTIONS

## Refrigerant Piping Insulation

### Refrigerant Piping System Insulation

All refrigerant piping from the outdoor unit to the indoor units must be insulated correctly for safety and usage. Y-branch connections, header branch connections, refrigerant piping, field-provided isolation ball valves (if present), service valves, and elbows must be properly and completely insulated using closed cell pipe insulation (up to the indoor unit piping connections). To prevent heat loss / heat gain through the refrigerant piping, all refrigerant piping including liquid lines and vapor lines shall be insulated separately. Insulation shall be a minimum 1/2" thick, and thickness may need to be increased based on ambient conditions and local codes. Table on next page lists minimum wall thickness requirements for Ethylene Propylene Diene Methylene (EPDM) insulation.

Inside the outdoor unit, maximum pipe temperature is 248°F and minimum pipe temperature is -40°F. For field insulation of refrigerant piping between outdoor units and indoor units, consider the following pipe temperature ranges for an operating heat pump system:

- Heating mode refrigerant temperature ranges: Liquid 75-118°F; High Pressure Vapor 95-220°F
- Cooling mode refrigerant temperature ranges: Liquid 75-118°F; Low Pressure Vapor 40-90°F

All insulation joints shall be glued with no air gaps. Insulation material shall fit snugly against the refrigeration pipe with no air space between it and the pipe. Insulation passing through pipe hangers, inside conduit, and/or sleeves must not be compressed. Protect insulation inside hangers and supports with a second layer. All pipe insulation exposed to the sun and outdoor elements shall be properly protected with PVC, aluminum vapor barrier, or alternatively placed in a weather-resistant enclosure such as a pipe rack with a top cover; and meet local codes. LG-provided Y-branches are shipped from the factory with pre-formed peel-and-stick foam insulation jackets, with a 1.84 lb./ft.<sup>3</sup> density, 1/2" thickness, and meet UL94 MF-1 flammability.

The design engineer should perform calculations to determine if the factory-supplied insulation jackets are sufficient to meet local codes and avoid sweating. Add additional insulation if necessary. Check the fit of the insulation jacket after the header fitting and all run-out pipes are installed. Mark all pipes at the point where the insulation jacket ends. Remove the jacket. Install field provided insulation on the run-out and main trunk pipes first. Install the LG-provided insulation plugs on the ends of all unused header ports. Peel the adhesive glue protector slip from the insulation jacket and install the clam-shell jacket over the fitting.

Figure 76: Typical Pipe Insulation, Power Wire and Communications Cable Arrangement

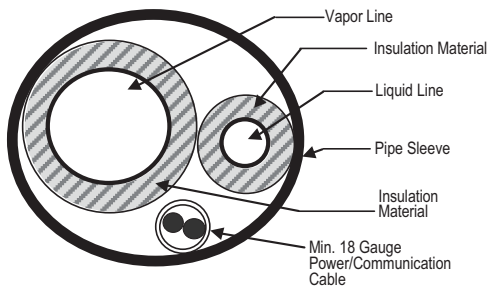

Figure 77: Typical Insulation Butt-Joint at Indoor Unit Casing

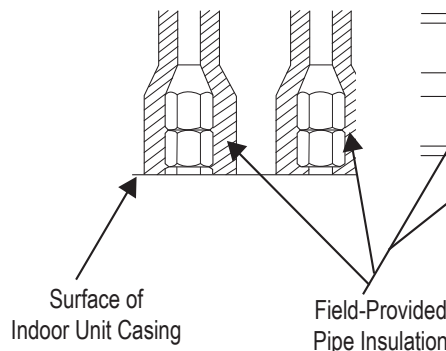
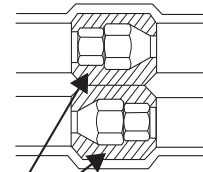

Figure 78: Typical Refrigerant Flare Fitting Insulation Detail



#### Note:

- Do not insulate gas and liquid pipes together as this can result in pipe leakage and malfunction due to extreme temperature fluctuations.
- Be sure to fully insulate the piping connections.



# REFRIGERANT PIPING CONNECTIONS

## Refrigerant Piping Insulation

### Minimum Refrigerant Pipe Ethylene Propylene Diene Methylene (EPDM) Insulation Wall Thickness Requirements

**Note:**

Follow locals codes when selecting EPDM insulation wall thickness.

Table 32: Insulation Guidelines for Typical and Special Circumstances

Classification		Air-conditioned location		Non-air conditioned location	
		1. Typical location	2. Special location	3. Typical location	4. Special location
Liquid pipe	ø1/4 inch	1/2 inch	1/2 inch	1/2 inch	1/2 inch
	ø3/8 inch				
	≥ø1/2 inch				
Vapor pipe	ø3/8 inch	1/2 inch	3/4 inch	3/4 inch	1 inch
	ø1/2 inch				
	ø5/8 inch				
	ø3/4 inch				
	ø7/8 inch				
	ø1 inch				
	ø1-1/8 inches	3/4 inch	1 inch	1 inch	
	ø1-1/4 inches				
	ø1-3/8 inches				
	ø1-1/2 inches				
	ø1-3/4 inches				

1. Typical location (Air-conditioned location): When the piping passes through an indoor area where the indoor unit operates.

- Apartment, classroom, office, mall, hospital, etc.

2. Special location (Air-conditioned location):

1. When the location is air conditioned, but there is severe temperature/humidity difference due to high ceilings
  - Church, auditorium, theater, lobby, etc.
2. When the location is air conditioned, but internal temperature/humidity are high
  - Bathroom, swimming pool, locker room, etc.

3. Typical location (Non-Air conditioned location): When the piping passes through an indoor area where the indoor unit does not operate.

- Hallway or a dormitory or school, etc.

4. Special location (Non-Air conditioned location): If conditions 1 and 2 below are present.

1. When the piping passes through an indoor area where the indoor unit does not operate.
2. When the humidity is high and there is no air flow in the location where the piping is installed.
  - The thickness of the above insulation material is based on heat conductivity of 0.61 Btu/in/h/ft<sup>2</sup>/°F.

# REFRIGERANT PIPING CONNECTIONS

## Pipe Sleeves at Penetrations

### Pipe Sleeves at Penetrations

LG requires that all pipe penetrations through walls, floors, and pipes buried underground be properly insulated and routed through an appropriate wall sleeve of sufficient size to prevent compression of refrigerant pipe insulation and free movement of the pipe within the sleeve. Underground refrigerant pipe shall be routed inside a protective sleeve to prevent insulation deterioration.

Figure 79: Pipe Sleeves at Penetrations

Inside wall (concealed)

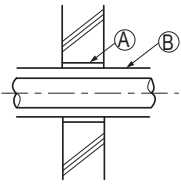

Outside wall

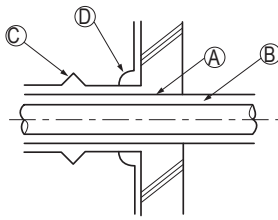

Outside wall (exposed)

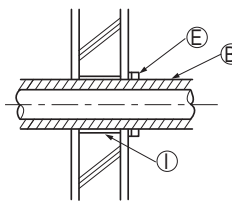

Floor (fire-resistance)

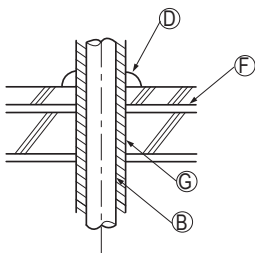

Roof pipe shaft

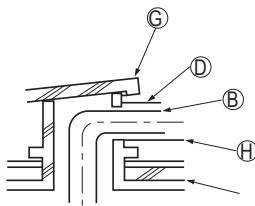

Area between fire-resistant insulation and boundary wall

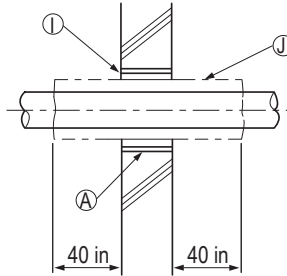

- Ⓐ Sleeve
- Ⓑ Insulation
- Ⓒ Lagging
- Ⓓ Caulk
- Ⓔ Band
- Ⓕ Water-resistant layer
- Ⓖ Sleeve with edge
- Ⓗ Lagging
- Ⓘ Mortar or other fire-resistant caulk
- ⓵ Fire-resistant insulation

When filling an access hole with mortar, cover the area with steel plate so that the insulation will not fall through. For this area, use fire-resistant materials for both the insulation and cover. (Vinyl cover should not be used.)

**Note:**

All floor and wall penetrations should be properly sized and large enough to accommodate pipe diameter plus insulation thickness.

# REFRIGERANT PIPING CONNECTIONS

## Air Purging

### Air Purging Best Practices

Air purging is done to the piping system after all piping has been connected between the indoor and outdoor unit. This step is necessary to be sure that refrigerant can flow through the system without danger of leakage or pressure issues. Air and moisture that is left in the piping can lead to undesirable results and can cause damage to the working unit. It is important to go through a complete air purging cycle to be sure that the lines are cleared out. Note that you may have to repeat this process should any air or moisture be found to remain in the piping. After air purging and evacuating the lines, be sure to take a leak test for all piping and tubing.

#### Note:

Insufficient or incorrectly done air purging may lead to the following:

- Pressure in the system can rise.
- Operating current can rise.
- Cooling or heating efficiency falls.
- Moisture in the refrigerant circuit may freeze and block capillary tubing
- Water can lead to corrosion of parts in the system.

### Air Purging with a Vacuum Pump - Preparation Steps

1. Verify that each set of pipes (liquid and gas) are properly connected between the indoor and outdoor unit.
2. Remove service valve caps from the gas and liquid valves at the outdoor unit (Figure 80).
3. Both the liquid and gas side service valves at the outdoor unit should be kept closed at this step.
4. Set up the purging, hose connections by referring to Figure 81.
5. Do a Leak Test, by proceeding to Soap Water Method - Leak Testing section on next page.
6. Successful leak testing must be performed before Evacuation can begin.
7. Go to *Evacuation* section, on page 51 to complete the purging process.

#### Note:

- Be sure to use a manifold valve for air purging. If it is not available, use a stop valve for this purpose.
- Be sure that the knob of the three-way valve is always kept close.

Table 33: Evacuation Table

Evacuation Table*	
Tubing = Less than 33 ft.	Tubing = More than 33 ft.
10 minutes or more	15 minutes or more

\* Required time for evacuation when 30 gal/h vacuum pump is used.

Figure 80: Removing Service Valve Caps - Outdoor Unit (appearance may be different depending on model)

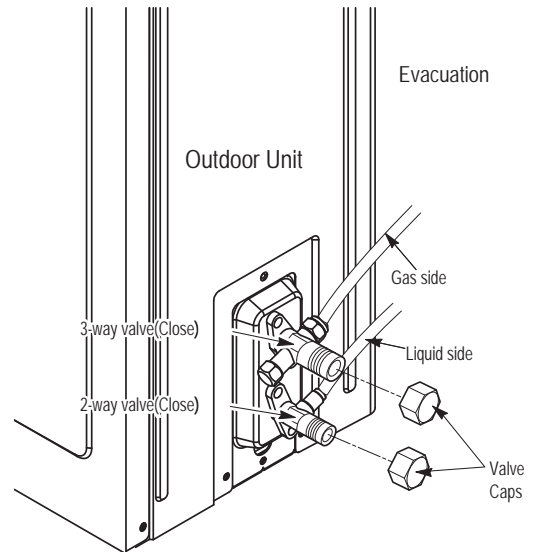
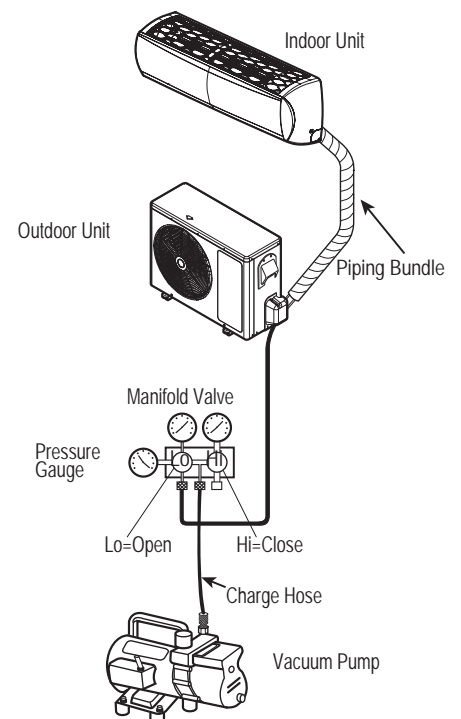

Figure 81: Evacuation Setup  
Air Purging / Evacuation Setup



# REFRIGERANT PIPING CONNECTIONS

## Leak Test/Soap Method Check

### Leak Test

#### Note:

Perform the leak test by pressurizing nitrogen gas to 550 psi on both the liquid and gas pipes. Test with the piping service valves closed. If the pressure does not drop for twenty-four (24) hours, the system passes the test. If the pressure drops, there is a nitrogen leak in the system. Find the leak, repair, and then test again.

#### Pressure Gauge Hookup

1. Connect the manifold valve (which includes the pressure gauges), along with dry nitrogen gas cylinder to the service valves using charge hose (Figure 82).
2. Pressurize the system to maximum 550 psig with dry nitrogen gas and close the cylinder valve when the gauge reading reaches 550 psig.

#### **⚠ DANGER**

Use of combustible gases including oxygen, may result in fire or explosion. There is risk of physical injury or death.

#### **⚠ WARNING**

Use of combustible gases including oxygen runs the risk of fire and explosion. Inert gas (nitrogen) should be used when checking plumbing leaks, cleaning or repairs of pipes, etc. There is risk of physical injury or death.

#### Note:

- To avoid nitrogen entering the refrigerant system in a liquid state, the top of the cylinder must be higher than its bottom when you pressurize the system.
- Be sure cylinder is used in a vertical standing position.

#### Soap Water Method - Leak Testing

1. Remove the caps from the 2-way and 3-way valves. See Figure 80.
2. To open the 2-way valve turn the valve stem counter-clockwise approximately 90°, wait for about 2~3 sec, and close it.
3. While running the nitrogen gas tank hookup, apply a soap water or a liquid neutral detergent on the indoor unit connection or outdoor unit connections by using a soft brush.
4. While running the pressure gauge system, observe the connections for any leakage.
  - If you see bubbles appearing at any of the connection points/joints (at either inside and outside units), it is an indication of a leak.
5. Make a note of where the leaks are coming from along the liquid and gas piping.
6. Disengage the nitrogen pressure by loosening the charge hose connector at the nitrogen cylinder (Figure 82 above).
7. Once system pressure is reduced back to normal range, disconnect hose from the cylinder.
8. At this point you will need to make all repairs to connections and piping where bubbles were observed.
9. Once all repairs are made, repeat soap testing using nitrogen cylinder and check for any further leaks.
10. Once system is leak free, proceed to Evacuation steps.

Figure 82: Leak Test Diagram.

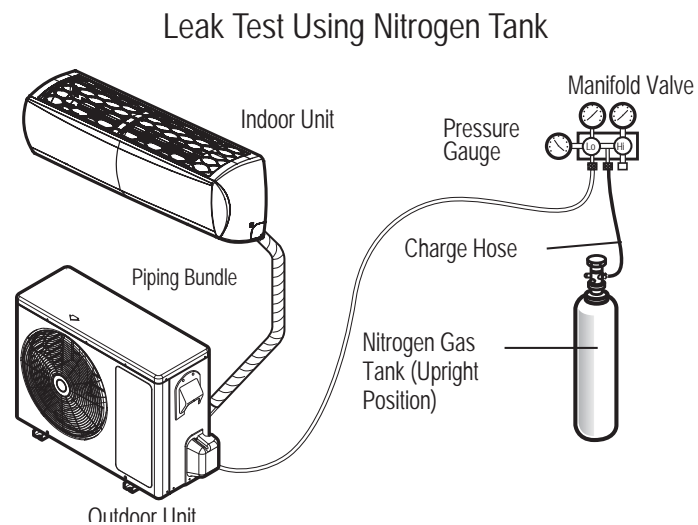

#### Leak Test Ambient Temperature Correction

If the ambient temperature changed between the time when pressure was applied and when the pressure drop was checked, adjust results by factoring in approximately 1.45 psi for each 2°F of temperature difference.

Correction formula = (Ambient temperature when pressure was applied - Ambient temperature when pressure drop was checked) x 0.01.

Example:

When pressure (550 psig) was applied, the ambient temperature was 80.6°F; 24 hours later when pressure drop (540 psi) was checked, ambient temperature was 68°F.

Thus,  $80.6 - 68 \times 0.01 = 0.126$ . In this case, the pressure drop of 0.126 was due to temperature difference, therefore, there is no leak in the refrigerant piping system.

# REFRIGERANT PIPING CONNECTIONS

## Evacuation of Lines Finishing Up

### Evacuation

After successful leak testing has been performed, follow Evacuation procedure. Follow the same steps for charge hose hookup to the system. See Figure 82 on previous page for proper hookup.

#### Procedure

1. Confirm that the “Lo” knob of the manifold valve is open. Refer back to Figure 82.
2. Confirm that the “Hi” knob of the manifold valve is left closed.
3. Run the Vacuum pump.
  - Operate pump until the system has been evacuated down to 300 microns.
  - Run pump an additional 15 minutes after reaching micron level.

The duration of the operation of the vacuum pump will vary according to pipe length and the capacity of the pump. Refer to Table 33 for accurate time duration.

### Finishing the Job

Once the Evacuation procedure has been performed, follow the steps below to turn off all valves at the outdoor unit and safely disengage the manifold valve, along with the vacuum pump. Refer back to the illustrations and tables on the previous pages as you go through the steps below.

#### Procedure

1. Using a wrench, turn the valve of the liquid stem counter-clockwise to fully open the valve (refer back to Figure 80).
2. Turn the valve of the gas stem counter-clockwise to fully open the valve.
3. Loosen the charge hose connected to the gas side service port slightly to release the pressure, and then remove the hose.
4. Replace the flare nut and its cap on the gas service port and fasten the flare nut securely using an adjustable wrench.
  - This process is very important to prevent leakage from the system.
5. Replace the valve caps at both gas and liquid side service valves and then fasten them tightly.
  - Once done, this will complete the air purging process with a vacuum pump.

4. Turn off the pump and leave the connections secured to the two service valves.
5. Wait 5 minutes.
6. If the system fails to hold 500 microns or less, check all connections for tight fit and repeat the evacuation procedure.
7. Once, desired vacuum is reached, close the “Lo” knob of the manifold valve and stop the vacuum pump.
8. Proceed to *Finishing the Job* section, below.

### Test Run

After leakage testing, and evacuation procedure the system should be ready to start up for a test run. Follow the guidelines below for proper procedure.

- Check that all tubing, piping and wiring are properly connected.
- Make sure that the gas and liquid service valves are fully open.
- Start up the system and do a test run.
- As system is up and running verify all is in working order and make notes as needed to work around any issues that might crop up.

### Installing Batteries into Remote Controller

As part of the test run, you will need to insert batteries and power on the remote controller. To insert the batteries follow the steps below. For information on using the remote controller, refer to its owner’s manual.

#### Procedure

1. The remote controller needs two AAA (1.5V) batteries for operation. Remove the battery cover from the back of the remote controller (Figure 83).
  - Push downward on the tab at the top of the battery cover and then lift up to remove.
2. Insert the two new batteries.
  - Align batteries by the (+) and (-) sides.
  - The interior battery compartment of the remote controller will have clear markings for the (+) and (-) placement.
3. Verify that the batteries have “clicked” into the compartment and are firmly engaged with the contacts on either side of them.
4. Reattach the back cover of the remote controller.
5. Proceed with powering on the remote controller and usage as needed.

Figure 83: Remote Controller - Installing Batteries  
Single Zone Remote Controller - Rear View

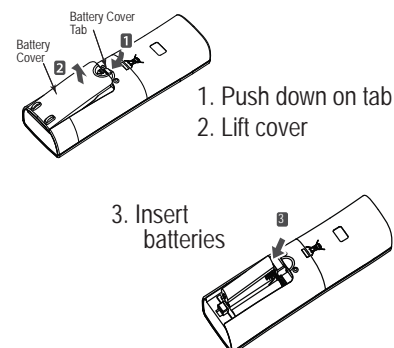

# REFRIGERANT PIPING CONNECTIONS

## Pump Down, Cooling Only Mode

### **⚠ WARNING**

⊘ Never air purge with refrigerant as it can lead to refrigerant leakage which can cause bodily harm and injury, especially if inhaled.

### **Note:**

Use a vacuum pump that can evacuate down to 500 microns.

1. If moisture remains in the piping after the system is evacuated for two (2) hours, break the vacuum (down to 7.5 psi with nitrogen gas).
2. Evacuate the system again with the vacuum pump for at least one (1) hour to 500 microns
3. If the system does not reach 500 microns within two (2) hours, repeat the vacuum break and evacuation procedure until the gauge does not rise.

## Pump Down Procedure

This procedure is performed when a unit has to be relocated or the refrigerant circuit is serviced. "Pumping down" is a term used to mean collecting all refrigerant into the outdoor unit without the loss of any refrigerant. Follow the procedure and guidelines below to safely collect refrigerant back into the outdoor unit. Always adhere to and be familiar with local codes regarding the handling of refrigerant.

The system must be placed in Cooling mode in order to proceed with the pump down procedure. If needed, refer to the sections below for proper steps to place the unit into Cooling Mode.

1. Connect a low-pressure gauge with manifold hose to the charge port on the gas line service valve.
2. Open the gas line service valve halfway.
3. Purge the air in the manifold hose using the refrigerant.
4. Close the liquid line service valve all the way.
5. Turn on the unit's power switch and start the cooling mode operation.
6. Observe the pressure gauge reading. When it gets to 1 to 0.5 kg/cm<sup>2</sup> (14.2 to 7.1 psig), fully close the gas line valve and then immediately turn the unit off.

• Pump down procedure is complete at this time and all refrigerant should be collected into the outdoor unit.

### **⚠ WARNING**

Never inhale or handle refrigerant directly. Doing so may cause bodily harm and injury.

### **Note:**

Perform Pump Down procedure only in the cooling mode.

## Enabling Cooling Only Mode

Before running the Pump Down procedure, you must place the unit into Cooling Only Mode. In order to be able to run Cooling Only Mode, you must enter the unit into the Installer Mode by pressing the Reset button and the JET MODE button simultaneously.

1. Shut down power to system completely.
  2. Enter the Installer Mode as stated in the paragraph above.
  3. Set code to 45.
  4. Press Power-ON button and select the code number 45.
- Unit should beep to acknowledge that code has been received.
5. Turn off power.
  6. Turn power back on to system.
- Let unit cycle off for a minimum of 30 seconds.

### **Note:**

- Once the system is in Installer Mode (with Cooling Only Mode initiated), automatic operation is suspended.
- Once Cooling Only Mode is disabled, the unit will return to normal operation.
- Installer Code cannot be entered if the unit is running. The system must be completely powered off.
- All Installer Code numbers must be entered into the system during Power Off state. (Complete shutdown of the system.)
- WLAN Module's communication time will lag by about 1 minute after unit is turned back on, and in normal operating mode.
- Entire lock or Mode lock cannot be set if you set heating or automatic operation through the central controller.

## Disabling Cooling Only Mode

After Pump Down procedure has been performed, you will need to disable Cooling Only Mode, and place the unit back into normal operating mode. Follow the procedure below.

1. Shut down power to system completely.
  2. Enter the Installer Mode.
  3. Set code to 46.
  4. Press Power-ON button and select the code number 46.
- Unit should beep to acknowledge that code has been received.
5. Turn off power.
  6. Turn power back on to system.
- Let unit cycle off for a minimum of 30 seconds.



# ELECTRICAL WIRING

## General Information and Safety Guidelines

### **⚠ WARNING**

- All power wiring and communication cable installation must be performed by authorized service providers working in accordance with local, state, and National Electrical Code regulations related to electrical equipment and wiring, and following the instructions in this manual.
- Undersized wiring may lead to unacceptable voltage at the unit and may cause a fire hazard, physical injury or death.
- Properly ground the Single Zone outdoor and indoor units. Ground wiring is required to prevent accidental electrical shock during current leakage.
- Ground wiring must always be installed by a qualified technician.
- ⓧ Do not connect ground wire to refrigerant, gas, or water piping; to lightning rods; to telephone ground wiring; or to the building plumbing system. Failure to properly provide a National Electrical Code-approved earth ground can result in electric shock, physical injury or death.
- Install appropriately sized breakers / fuses / overcurrent protection switches and wiring in accordance with local, state, and National Electrical Code regulations related to electrical equipment and wiring, and following the instructions in this manual. Using an oversized breaker or fuse may result in electric shock, physical injury or death.

### **Note:**

- Consider ambient conditions (temperature, direct sunlight, inclement weather, etc.) when selecting, installing, and connecting the power wiring.
- Properly ground the Single Zone outdoor and indoor unit. Improperly ground wire can cause communication problems from electrical noise, and motor current leakage. Ground wiring must always be installed by a qualified technician.
- If the system operates in reversed phase, it may damage the compressors and other components.
- If there is a possibility of reversed phase, phase loss, momentary blackout, or the power goes on and off while the system is operating, install a field-supplied phase loss protection circuit.
- ⓧ Do not connect ground wire to refrigerant, gas, or water piping; to lightning rods; to telephone ground wiring; or to the building plumbing system. Failure to properly provide a National Electrical Code-approved earth ground can result in property damage and equipment malfunction.
- Install appropriately sized breakers / fuses / overcurrent protection switches and wiring in accordance with local, state, and National Electrical Code regulations related to electrical equipment and wiring, and following the instructions in this manual. Using an oversized breaker or fuse may result in equipment malfunction and property damage.
- Undersized wiring may lead to unacceptable voltage at the unit and may cause unit malfunction.

## Power Supply / Power Wiring Specifications

### **Note:**

- Single Zone systems operate at 1Ø, 208-230V, 60Hz, with the exception of Mega 115V, which operates at 1Ø, 115V, 60Hz.
- Power supply, wire type and size should be selected based on National Electrical Code and local codes. Maximum allowable voltage fluctuation  $\pm 10\%$  or nameplate rated value.
- Properly ground the Single Zone outdoor unit and indoor unit per National Electrical Code and local codes.
- For power to the outdoor unit, use copper wiring that is solid or stranded that complies with all local and national electrical codes.
- Ground wire should be longer than the common power/communication wires.
- Refer to the inside of the Chassis Cover for Circuit and Terminal Block Diagrams for your model unit.
- Always match color codes of each wire and follow wiring diagram.

# ELECTRICAL WIRING

## Power Wiring Specifications and Best Practices

### Connecting the Power Wiring Guidelines

Best practice dictates using ring or spade terminals to terminate power wiring at the power terminal block (Figure 85).

If ring terminals or spade clips are not available, then:

**⚠ WARNING**

⊘ Do not terminate different gauge wires to the power terminal block. Slack in the wiring may generate heat and fire.

**Note:**

- When terminating wires of the same thickness, follow the instructions demonstrated in the illustrations below at Figure 86.
- Firmly attach the wire; secure in a way to prevent external forces from being imparted on the terminal block.
- Use an appropriately sized screwdriver for tightening the terminals.
- ⊘ Do not over tighten the connections; overtightening may damage the terminals.

Figure 85: Close up of a Typical Ring Terminal

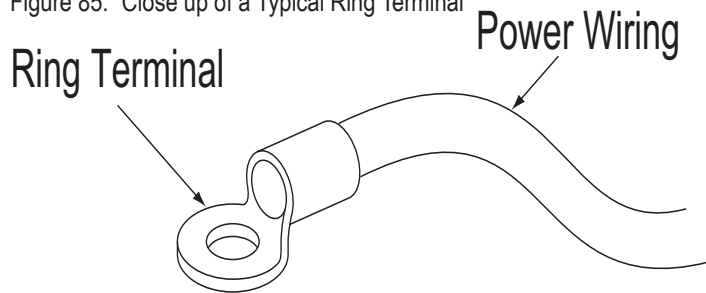
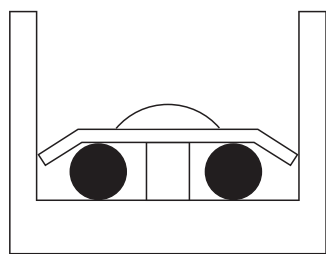
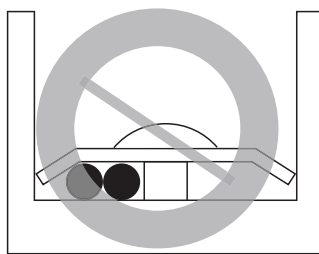

Figure 86: Proper and Improper Power Wiring Connections



Terminate multiple power wires of the same gauge to both sides.



Do not terminate two wires on one side.

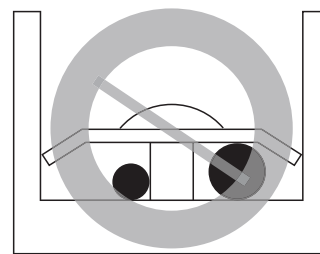

Do not terminate different gauge wires to a terminal block.

● :Copper Wire

**⚠ WARNING**

- If power wires are not properly terminated and firmly attached, there is risk of fire, electric shock, and physical injury or death.
- ⊘ Never ground the shield of the communications cable to the indoor unit frame or other grounded entities of the building.

**Note:**

- ⊘ Never apply line voltage power to the communications cable terminal block. If contact is made, the PCBs may be damaged.
- Always include some allowance in the wiring length when terminating. Provide some slack to facilitate removing the electrical panels while servicing.

Figure 84: Single Zone Outdoor and Indoor Wiring and Communications Cable Diagram

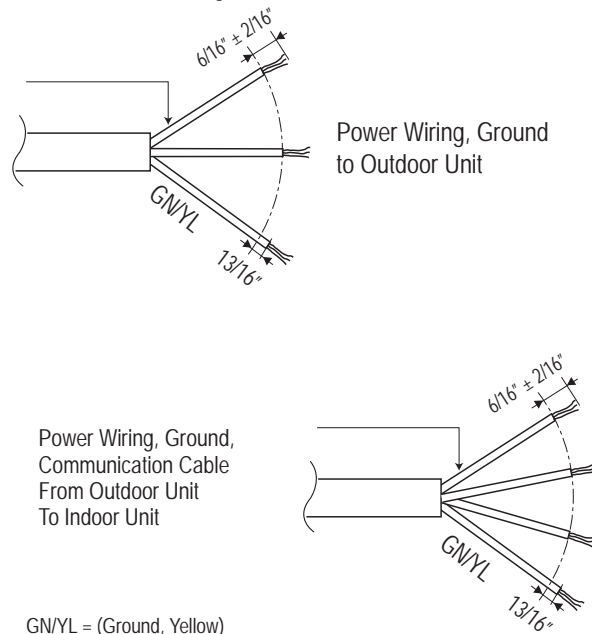

# ELECTRICAL WIRING

## Power Wiring Specifications and Best Practices

### General Communication Cable Specifications

- For power / communication wires between the Single Zone outdoor unit and the indoor unit, use a four (4) conductor, stranded, shielded or unshielded wire. If shielded, the wire must be grounded to the chassis at the outdoor unit only.
- Minimum 18 gauge CVVS or CPEVS cable.
- Insulation material as required by local code.
- Rated for continuous exposure of temperatures up to 140°F.
- Maximum allowable cable length: 984 feet.
- Firmly attach the cable; provide slack but secure in a way to prevent external forces from being imparted on the terminal block.
- Wiring should be completed without splices.

#### Note:

- Always verify the communication cable is connected to a communications terminal on the Single Zone unit. ⚠ Never apply line voltage power to the communication cable connection. If contact is made, the PCBs may be damaged.
- The shield of the communications cable connecting the outdoor unit to the indoor unit should be grounded only to the outdoor unit frame.
- Tie the shield of each cable segment together using a wire nut at the indoor unit. Maintain polarity throughout the communication network.
- Position the incoming power to the outdoor unit away from the power / communications cables from the outdoor unit to the indoor unit.
- ⚠ Never use a common multiple-core communications cable. Each communications bus shall be provided a separate cable (i.e., between outdoor unit and indoor unit).

### Communication Cables Between the Single Zone Unit and the Controller

- Simple Controllers: field-provided, 18 gauge, stranded four-conductor communication cable (shielded).
- All other Central Controllers: field-provided, 18 gauge, stranded two-conductor communication cable (shielded).
- Insulation material as recommended by local code.
- Connect all central control devices such as ACP, BACnet® and LonWorks® gateways, and energy recovery ventilators all on the same cable. Order does not matter. Polarity does. Keep “A” terminals with “A” terminals, and “B” terminals with “B” terminals.
- Starting at the outdoor unit, terminate the cable on terminals Internet A and Internet B. Route the cable as needed between each device.

### Controller Options

Refer to Table 34 as to which remote controller models to use for each Single Zone model types. Once all wiring is connected to the indoor and outdoor units be sure to test the accompanying remote controllers for performance. As always, follow all safety warnings and notes when operating the Single Zone units using the remote controller.

Additionally, most of the Single Zone High Efficiency and Extended Pipe outdoor models can use the following controllers when accompanied with the PI 485 VNet Accessory:

- AC Smart
- ACP
- BACnet™
- LonWorks™
- LGMV

Mega 115V is compatible with the following controllers:

- PREMTB10U
- PQDSB1
- PZCWR5C1

#### Note:

- LS091HSV3, LS121HSV3 models cannot use PI-485, or the controller accessories.
- Single Zone Mega and Mega 115V systems cannot use PI-485, or the controller accessories mentioned on this page. They can use LGMV.
- BACnet™ is a trademark of ASHRAE; LonWorks™ is a trademark of Echelon Corporation.

Table 34: Single Zone Models and Associated Remote Controller Model

Single Zone Model Type	Remote Controller Model
LS091HSV3, LS121HSV3	AKB73855712
LS181HSV3	AKB73855712
LS240HSV3	AKB73855713
LS307HV3, LS360HV3	AKB73855713
<b>Single Zone Extended Pipe System</b>	
LS240HLV, LS300HLV, LS360HLV	AKB74055401
<b>Single Zone Mega System (HEV)</b>	
LS090HEV, LS120HEV	AKB73835305
LS180HEV, LS240HEV	AKB73835305
<b>Single Zone Mega System (HEV1)</b>	
LS090HEV1, LS120HEV1	AKB73835318
LS180HEV1, LS240HEV1	AKB73835318
<b>Single Zone Mega 115V System</b>	
LS090HXV, LS120HXV	AKB73456121

# ELECTRICAL WIRING

## Indoor Unit Electrical Connections

### Overview - Connecting Indoor Unit Electrical Wiring

The general guidelines for connecting electrical and communication cables to the indoor unit are the same for each of the Single Zone Wall Mounted indoor units, however, the actual connections on the terminal block will differ. See each illustration for the Single Zone unit model that you are wiring for correct contact on each terminal block. Depending on your indoor unit, the location of the terminal block on the indoor unit might vary slightly from the images shown in this section.

#### ⚠ WARNING

- Be sure that main power to the unit is completely off before proceeding with these steps.
- Follow all safety and warning information outlined at the beginning and throughout this manual. Failure to do so may cause bodily injury.

#### Note:

- Follow all safety and warning information outlined at the beginning and throughout this manual. Failure to do so may cause unit failure.
- Some units might require you to remove the Control Cover from the terminal block area. Most Control Covers are attached with a phillips screw head.
- Connect the electrical cable to the indoor unit by connecting the wires to the terminals on the control board individually according to the outdoor unit connection. Be sure that the color of the wires at the outdoor unit along with the terminal numbers are the same as those for the indoor unit.

#### Procedure

#### ⚠ WARNING

Be sure there is no power going through the Single Zone system before proceeding with these connections as there be a risk of electrical shock and bodily injury.

1. At the bottom panel of the indoor unit, unsnap the latches which cover the phillips screw heads as shown in Figure 87.
- Normally, there are three (3) screws on the panel, however your indoor unit model may differ.
2. Using a phillips head screwdriver, remove the screws from the bottom panel of the indoor unit and set aside (Figure 88).
3. Remove the bottom panel (Figure 89).
- Removal is necessary to gain access to the terminal block which is situated at the bottom of most indoor units.
- Note that the electrical/communications wiring is usually routed through the back/bottom of the indoor unit (through a knockout panel) as shown on the next page (Figure 90).
4. Using a screwdriver, connect the wires as shown on the next page (Figure 91).
- Each wire should be securely attached to the terminal block.
- Pay attention to the location/connection of the green/yellow ground cable.

Figure 87: Latch over Screws on Bottom Panel, Indoor Unit



Figure 88: Remove Screws from Bottom Panel



Figure 89: Remove (and Reattachment) Bottom Panel





# ELECTRICAL WIRING

## Indoor Unit Electrical Connections

### Connecting Indoor Unit Electrical Wiring - Continued

- When done, reattach the bottom panel to the indoor unit, being careful to align panel using the rear tabs.
  - You might need to give the panel a gentle tap with the palm of your hand to be sure it engages at the bottom.
- Using a phillips screwdriver, reattach the screws to the bottom panel and secure.
- Once screws are in place, re-snap the latches over the screws.
  - Refer back to Figure 87 as an example.
- If all other piping and electrical wiring to the outside unit has been completed at this stage, you can turn the system on to test.
  - If you have not completed the piping connections, ⚡ do not turn power on at this time and proceed to complete all other piping, (along with drain hose) and wiring to the system.

Figure 90: Indoor Unit Knockout (Communication Wires)



Figure 91: Indoor Unit Terminal Block with Grounding Cable (Example Only)

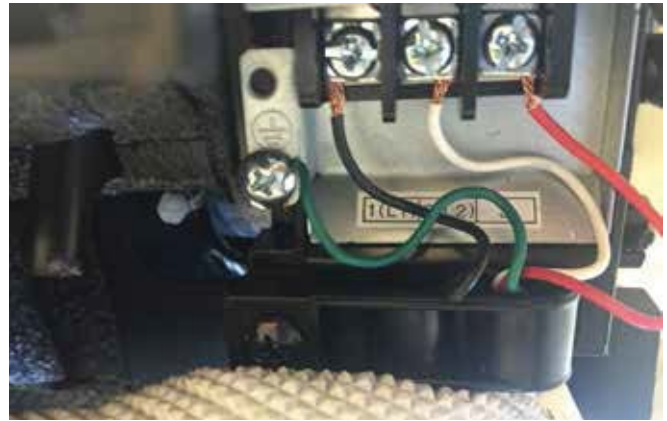

### Terminal Block Connection for HLV

See Figure 92 for specific terminal block wiring for all following Single Zone models:

LSN240HLV

LSN300HLV

LSN360HLV

Figure 92: HLV Indoor Units - Terminal Block Connections

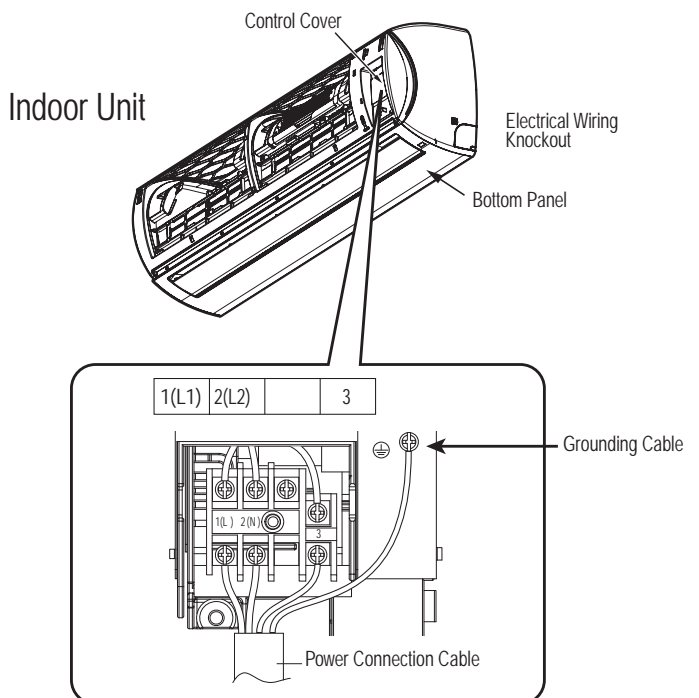

# ELECTRICAL WIRING

## Indoor Unit Electrical Connections

### Terminal Block Connection for HV3

See Figure 93 for specific terminal block wiring for all following Single Zone models:  
 LSN307HV3  
 LSN360HV3

### Terminal Block Connection for 240HSV3

See Figure 93 for 240HSV3 Single Zone terminal block connection. The connections are also identical for LSN307HV3 and LSN360HV3 Single Zone models.

Figure 93: HV3 and 240HSV3 Indoor Units - Terminal Block Connections

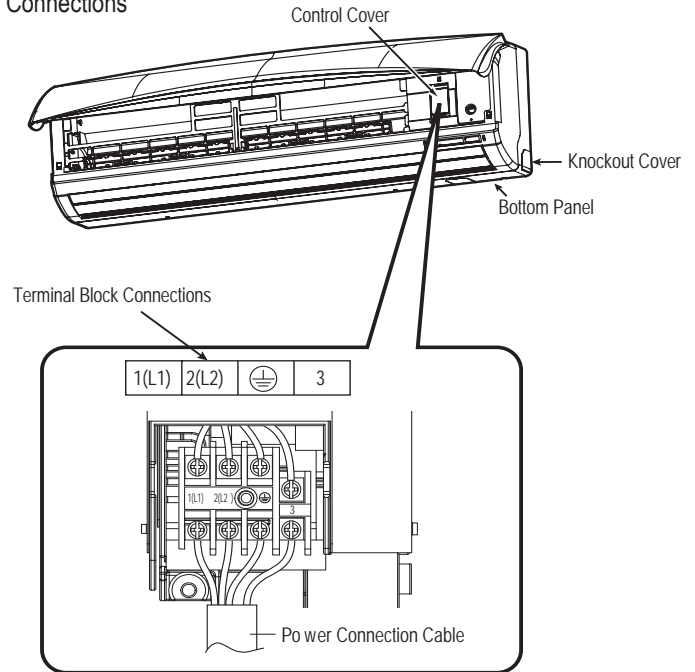

Figure 94: 091HSV3, 121HSV3, 181HSV3 Indoor Units - Terminal Block Connections

### Terminal Block Connection for 091HSV3, 121HSV3, 181HSV3

See Figure 94 for specific terminal block wiring for all following Single Zone models:  
 LSN091HSV3  
 LSN121HSV3  
 LSN181HSV3

**Note:**

- Pay special attention to the location of the grounding cable and the cable restrainer around the other electrical/communication cables when connecting.
- Note that the terminal block is located behind the drain hose and bundled piping on these units.

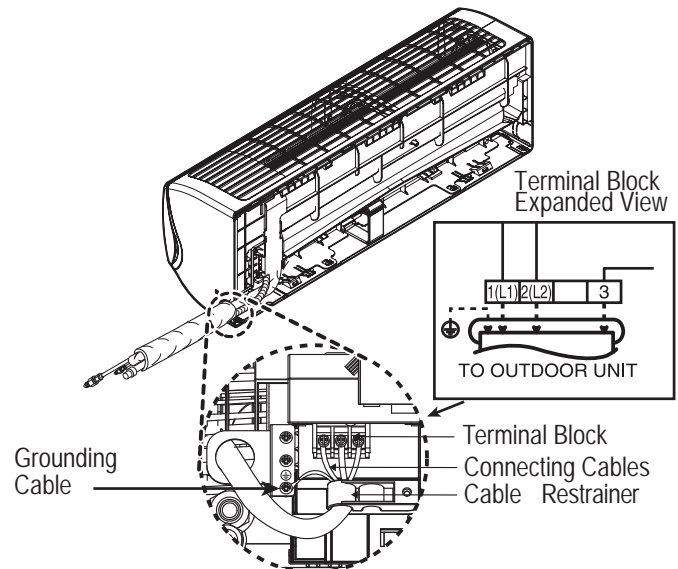



# ELECTRICAL WIRING

## Indoor Unit Electrical Connections

### Terminal Block Connection for Mega 090HEV, 090HEV1, 120HEV, 180HEV, 240HEV

See Figure 95 for specific terminal block wiring for the following Single Zone models:

LSN090HEV  
LSN090HEV1  
LSN120HEV  
LSN180HEV  
LSN240HEV

Figure 95: Mega 090HEV, 090HEV1, 120HEV, 180HEV, 240HEV Indoor Units - Terminal Block Connections

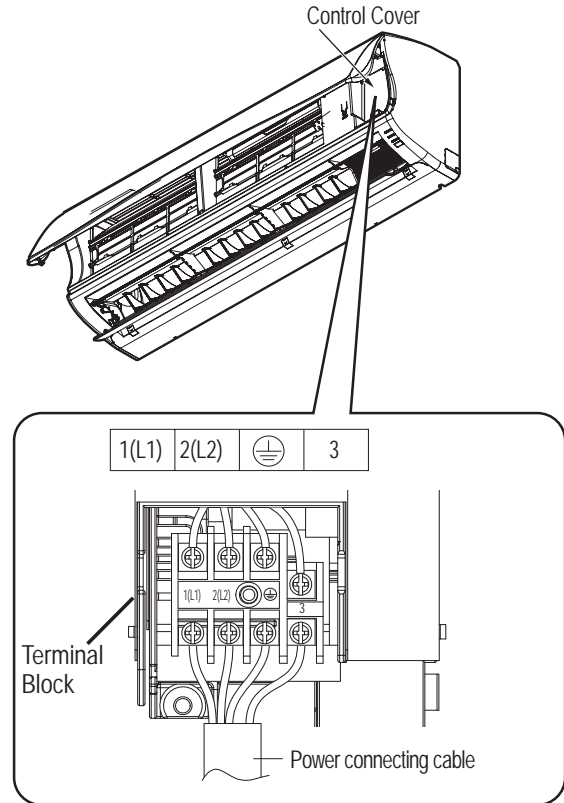

### Terminal Block Connection for Mega 120HEV1

See Figure 96 for specific terminal block wiring for the following Single Zone models:

LSN120HEV1

Figure 96: Mega 120HEV1 Indoor Units - Terminal Block Connections

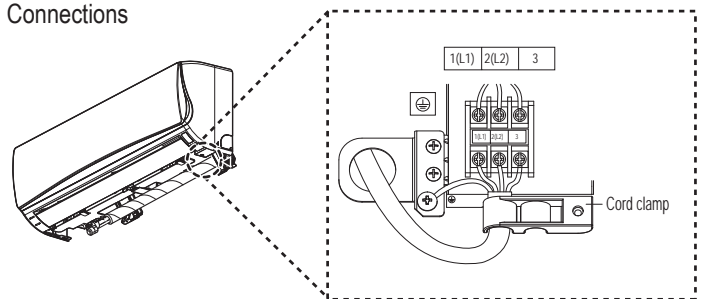

# ELECTRICAL WIRING

## Indoor Unit Electrical Connections

### Terminal Block Connection for Mega 180HEV1, 240HEV1

See Figure 97 for specific terminal block wiring for the following Single Zone models:

LSN180HEV1  
LSN240HEV1

Figure 97: Mega 180HEV1, 240HEV1 Indoor Units - Terminal Block Connections

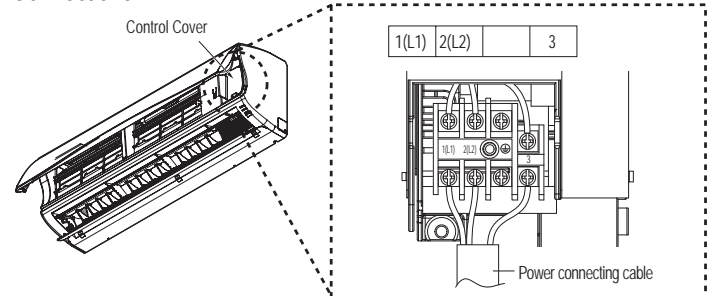

### Terminal Block Connection for Mega 115V 090HXV, 120HXV

See Figure 98 for specific terminal block wiring for all following Single Zone models:

LSN090HXV  
LSN120HXV

Figure 98: Mega 115V 090HXV, 120HXV Indoor Units - Terminal Block Connections

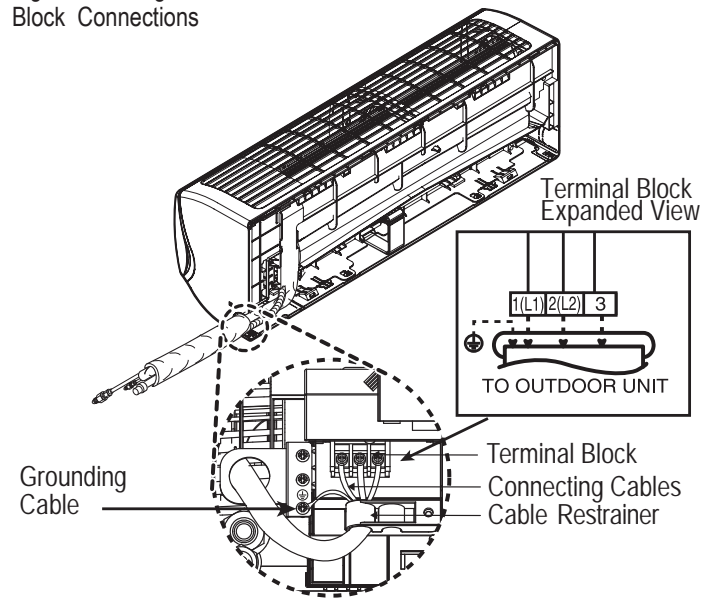

# ELECTRICAL WIRING

## Outdoor Unit Electrical Connections

### Connecting Outdoor Unit Electrical Wiring

The general guidelines for connecting electrical and communication cables to the outdoor unit are the same for each of the Single Zone Wall Mount units, however, the actual connections on the terminal block will differ. See each illustration for the Single Zone unit model that you are installing for correct wiring of each terminal block.

#### ⚠ WARNING

- Be sure that main power to the unit is completely off before proceeding with these steps. Follow all safety and warning information outlined at the beginning of this manual. Failure to do so may cause bodily injury.
- Be sure that a circuit breaker or some other emergency power cutoff device is in place before any power wiring is done to the system. Failure to do so, may cause bodily injury or death.
- ⚡ Never touch any power lines or live cables before all power is cutoff to the system. To do so, may cause bodily injury or death.

#### Procedure

Refer to Figure 99 for an example of how a circuit breaker should be wired through to the Single Zone system.

#### ⚠ WARNING

- Be sure there is no power going through the Single Zone system before proceeding with these connections as it may result in electric shock.
- Familiarize yourself with the location of the circuit breaker and be sure that all power is cut to the Single Zone unit as it may result in electric shock.

1. Using a phillips head screwdriver, remove the conduit panel cover from the outside unit.
2. Before proceeding, inspect all wiring inside the casing to be sure they are secure and have not come loose during transportation and installation of the outdoor unit.
- Loose wires can cause the wiring to burn out quickly.
- Inspect wires for any damage or cracks (manufacturing defects).
3. Confirm that electrical power supply capacity is sufficient to run the unit. See specifications sheets at the beginning of this installation manual for details on power.
4. Confirm that you are using the right gauge size for wiring to proceed.
5. Using a screwdriver, connect the wires as shown in Figure 100.

- Figure 100 shows the connections for the HLV models, however the basic connection procedure is the same for all models. Use this diagram as a general reference on connecting the power cables.
- Each wire should be securely attached to the terminal block.
- Bundle the cabling by using a cable restrainer.
- Pay attention to the location/connection of the green/yellow grounding cable; as in some models the connection may be located to the side of the actual terminal block.
- Maintain a minimum of .2" of wire length from terminal block to cable bundle.

Figure 99: Circuit Breaker Main Power Source

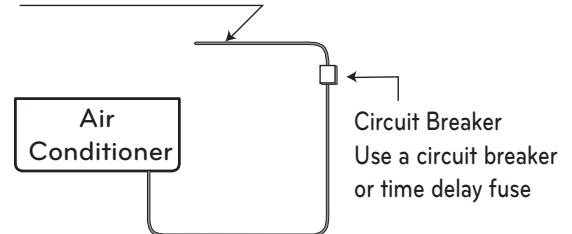
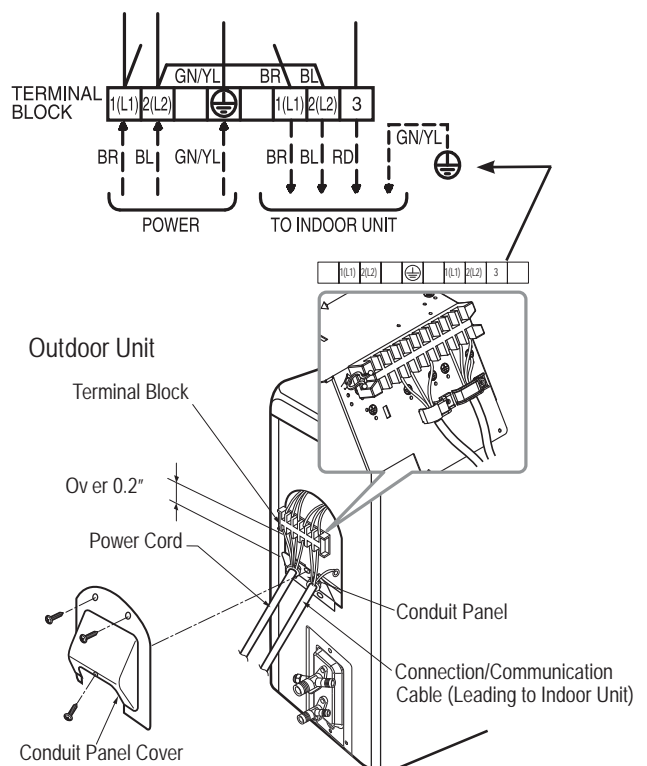

Figure 100: HLV Outdoor Unit - Electrical Connections



### Terminal Block Connection for HLV

See Figure 100 for specific terminal block wiring for all following Single Zone outdoor unit models:

- LSN240HLV
- LSN300HLV
- LSN360HLV

# ELECTRICAL WIRING

## Outdoor Unit Electrical Connections

### Terminal Block Connection for HV3

See Figure 101 for specific terminal block wiring for all following Single Zone outdoor unit models:

- LSU307HV3
- LSU360HV3

### Terminal Block Connections for 181HSV3 and 240HSV3

See Figure 101 for 181HSV3 and 240HSV3 Single Zone terminal block connections. The connections are identical to the HV3 outdoor units.

Figure 101: HV3 and 181HSV3, 240HSV3 Outdoor Unit - Electrical Connections

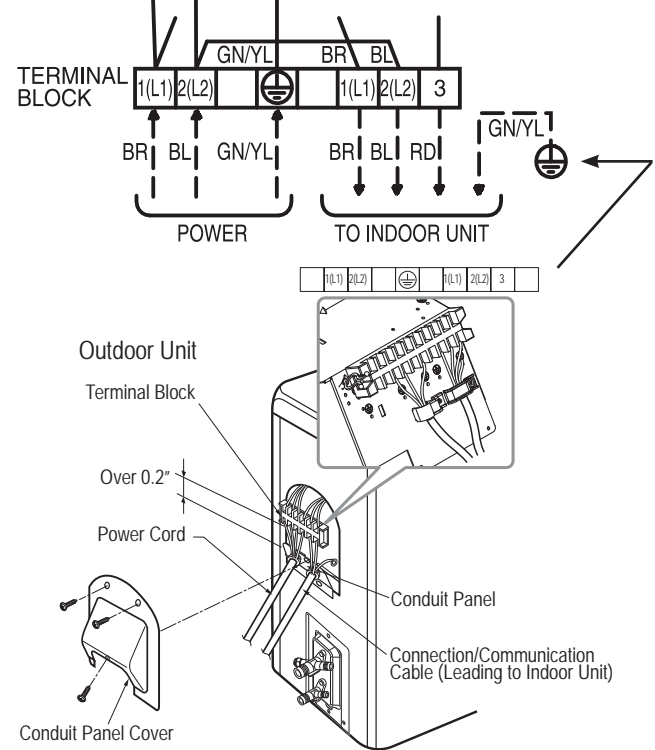

### Terminal Block Connection for 091HSV3, 121HSV3

See Figure 102 for specific terminal block wiring for all following Single Zone outdoor unit models:

- LSU091HSV3
- LSU121HSV3

Figure 102: 091HSV3, 121HSV3 Outdoor Unit - Electrical Connections

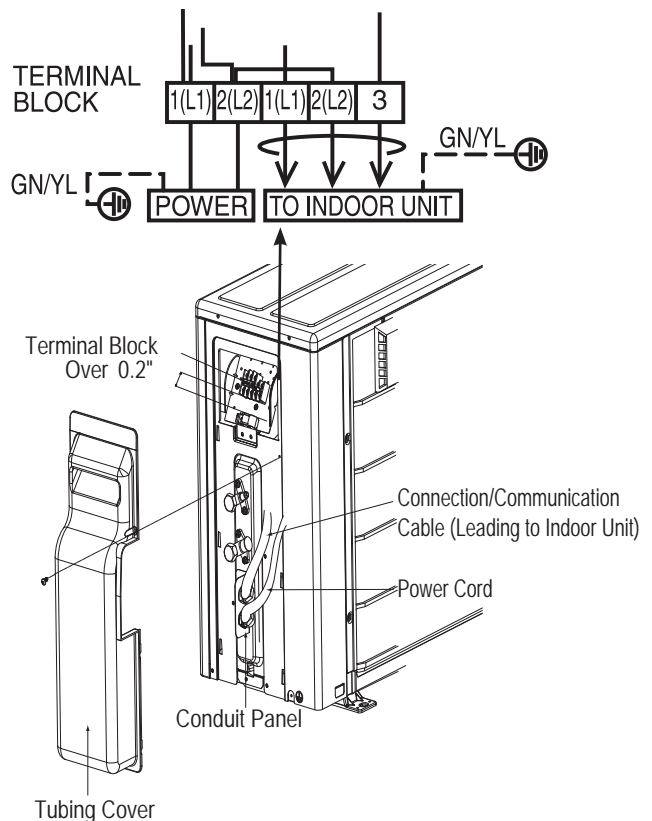

# ELECTRICAL WIRING

## Outdoor Unit Electrical Connections

### Terminal Block Connection for 090HEV, 090HEV1, 120HEV, 120HEV1

See Figure 103 for specific terminal block wiring for all following Single Zone outdoor unit models:

- LSU090HEV
- LSU090HEV1
- LSU120HEV
- LSU120HEV1

Figure 103: 090HEV, 090HEV1, 120HEV, 120HEV1 Outdoor Unit - Electrical Connections

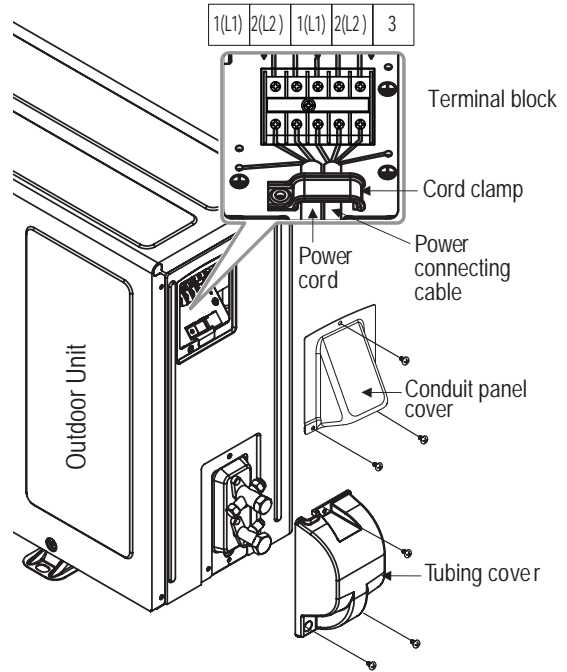

### Terminal Block Connection for 180HEV

See Figure 104 for specific terminal block wiring for all following Single Zone outdoor unit models:

- LSU180HEV

Figure 104: 180HEV Outdoor Unit - Electrical Connections

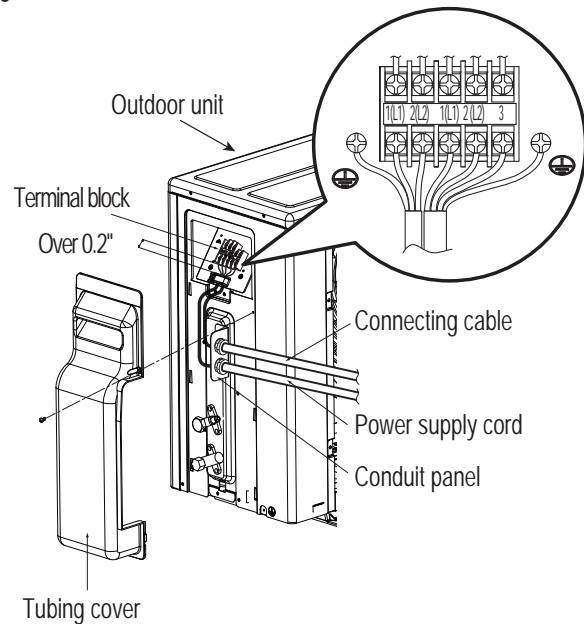

# ELECTRICAL WIRING

## Outdoor Unit Electrical Connections

### Terminal Block Connection for 180HEV1

See Figure 105 for specific terminal block wiring for all following Single Zone outdoor unit models:  
LSU180HEV1

Figure 105: 180HEV1 Outdoor Unit - Electrical Connections

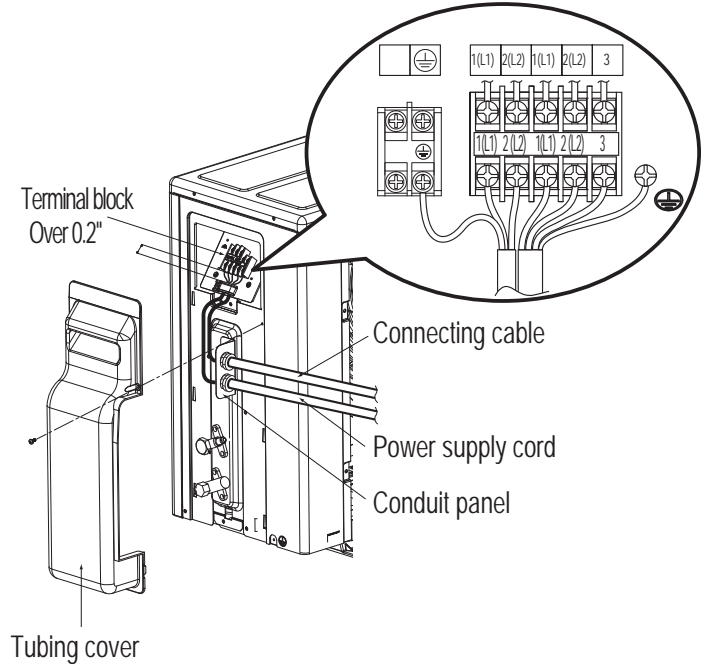

### Terminal Block Connection for 240HEV

See Figure 106 for specific terminal block wiring for the following Single Zone outdoor unit model:  
LSU240HEV

Figure 106: 240HEV Outdoor Unit - Electrical Connections

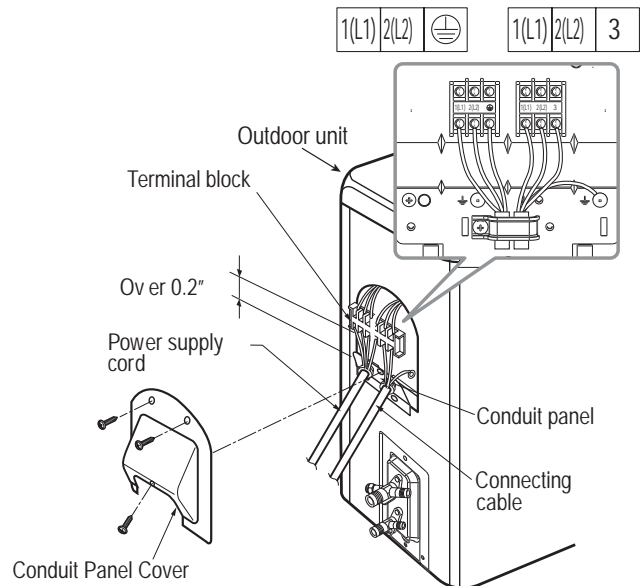



# ELECTRICAL WIRING

## Outdoor Unit Electrical Connections

### Terminal Block Connection for 240HEV1

See Figure 107 for specific terminal block wiring for the following Single Zone outdoor unit model:  
LSU240HEV1

Figure 107: 240HEV1 Outdoor Unit - Electrical Connections

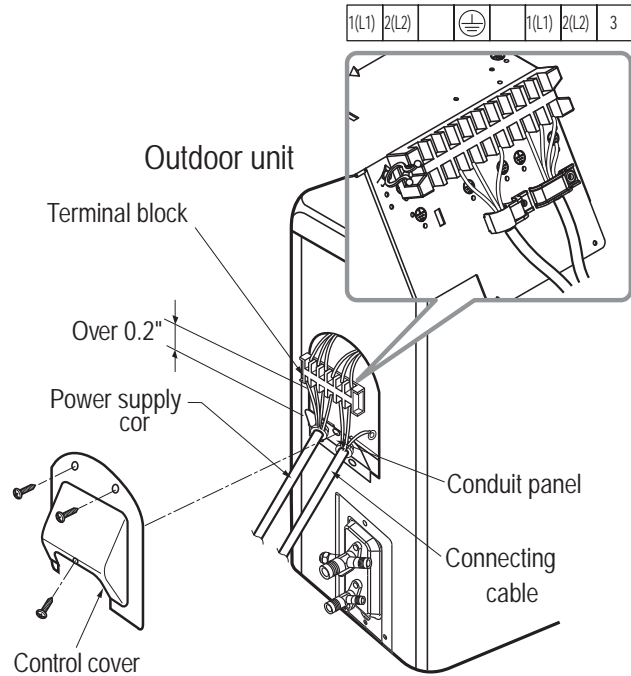

### Terminal Block Connection for HXV

See Figure 108 for specific terminal block wiring for all following Single Zone outdoor unit models:  
LSN090HXV  
LSN120HXV

Figure 108: 090HXV, 120HXV Outdoor Unit - Electrical Connections

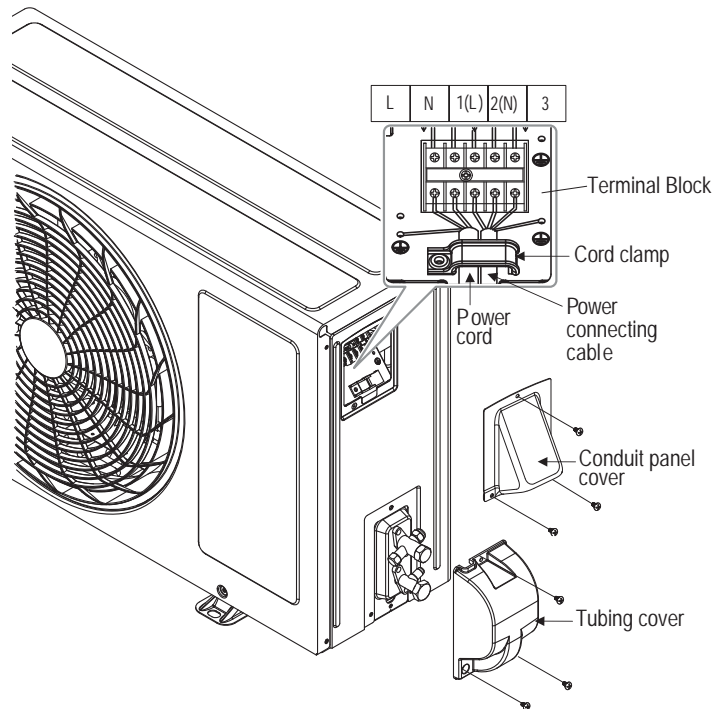

# ELECTRICAL WIRING

## Self Diagnosis Functions

### LG Monitoring View (LGMV) Diagnostic Software

LGMV software (PRCTSL1 and PRCTFE1) allows the service technician or commissioning agent to connect a computer USB port to the Single Zone system's main printed circuit board (PCB) using an accessory cable without the need for a separate interface device. The monitoring screen for LGMV allows the user to view the following real time data on one screen (Figure 109):

- Actual inverter compressor speed
- Target inverter compressor speed
- Actual outdoor fan speed
- Target outdoor unit fan speed
- Actual superheat
- Target superheat
- Actual subcooler circuit superheat
- Target subcooler circuit superheat
- Main EEV position
- Subcooling EEV position
- Inverter compressor current transducer value
- Outdoor air temperature
- Actual high pressure/saturation temperature
- Actual low pressure/saturation temperature
- Suction temperature
- Inverter compressor discharge temperature
- Front outdoor coil pipe temperature
- Back outdoor coil pipe temperature
- Liquid line pipe temperature
- Subcooler inlet temperature
- Subcooler outlet temperature
- Average indoor unit (IDU) pipe temperature
- Inverter compressor operation indicator light
- Liquid injection valves' operation indicator lights
- Hot gas bypass valve operation indicator light
- Four-way reversing valve operation indicator light
- Pressure graph showing actual low pressure and high pressure levels
- Error code display
- Operating mode indicator
- Target high pressure
- Target low pressure
- PCB (printed circuit board) version
- Software version
- Installer name
- Model number of IDUs
- Site name
- Total number of connected IDUs

Figure 109: MV Real-time Data Screen



- Communication indicators
- IDU capacity
- IDU operating mode
- IDU fan speed
- IDU EEV position
- IDU room temperature
- IDU inlet pipe temperature
- IDU outlet pipe temperature
- IDU error code

Additional screens can be accessed by tabs on the main screen.

Additional screens include the following:

1. Cycleview (Figure 110): Graphic of internal components including:
  - Compressors showing actual speeds
  - EEVs
  - IDUs
  - Temperature and pressure sensors
  - Four-way reversing valve
2. Graph: Full screen graph of actual high and low pressures and high and low pressure limits. A sliding bar enables user to go back in time and view data.
3. Control FTN: Enables user to turn on IDUs in 1.8 °F increments.
4. Useful Tab
  - Unit Conversion: Converts metric values to imperial values.

Figure 110: MV Cycleview

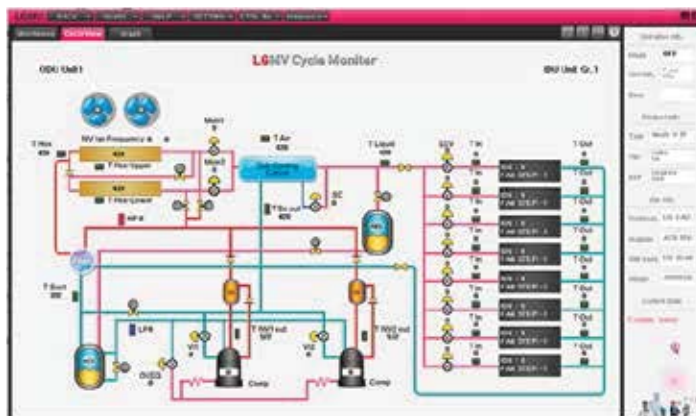

#### Note:

Images on these pages are examples of LGMV screenshots. Actual images may differ depending on the version of the software and the unit installed.

### LG Monitoring View (LGMV) Diagnostic Software and Cable - Continued

#### 5. Data (Figure 111)

- Data Saving Start: Recording of real time data to a separate file created to be stored on the user's computer.
- Data Loading Start: Recorded data from a saved ".CSV" file can be loaded to create an LGMV session.

#### 6. Monitoring

- Electrical: The lower half of main screen is changed to show Inverter Compressor Amps, Volts, Power Hz, Inverter control board fan Hz.

Figure 111: MV Control Indoor Units Screen



## Error Codes

LGMV software helps the service technician or commissioning agent to troubleshoot system operation issues by displaying malfunction codes (Figure 112). These error codes can be seen on the main screen of the LGMV software program. For an overview of Single Zone unit error codes, see Error Codes section. For detailed information on how to troubleshoot individual error codes, see the Single Zone Service Manual.

Figure 112: Error Code Screen



The software is available in a high version with all of the features listed above. The low version has all features as the high version without Target High Pressure and Target Low Pressure values shown on main screen.

In lieu of connecting to the outdoor unit, user has the option to connect to IDU with the use of a USB to RS-485 connector kit. When connected through IDU, user will not be able to record data.

This software can be used to both commission new systems and troubleshoot existing systems. LGMV data can be recorded to a ".CSV" file and emailed to an LG representative to assist with diagnostic evaluations.

#### Recommended Minimum PC Configuration:

- CPU: Pentium® IV 1.6 GHz
- Main Memory: 1G
- Operating System: Windows® XP/Vista/7 32 bit (recommended), 64 bit
- Hard Disk: 600 MB when operating
- MS Office 2003, 2007 (recommended) for select reporting functions

#### Note:

Images on these pages are examples of LGMV screenshots. Actual images may differ depending on the version of the software and the units installed.

# ELECTRICAL WIRING

## LG SIMS - Self Diagnosis Functions

The SIMs WLAN module and the smart phone app together provide monitoring and troubleshooting capability for LG Duct Free Systems. SIMs functions only with LG Duct Free products (Figure 113).

SIMs can display and graph operational data for the air conditioner system including the indoor unit and the outdoor unit. SIMs also displays error codes and a troubleshooting guide. A full copy of the LG SIMs Smart Inverter Monitoring System User's Manual is available on the www.lghvac.com website.

To use SIMs you must be a trained HVAC service technician familiar with variable refrigerant flow (VRF) systems in general and with LG's Duct Free System products. You should understand the inverter air conditioning operation cycle, the meaning of the data displayed by SIMs, and how to use the data to troubleshoot the system.

Figure 114 shows a Multi F configuration used with the SIMs module and app. LG SIMs can also be used with Single Zone one-to-one configurations such as the Single Zone Wall Mount systems.

Figure 113: LG SIMs App and WLAN Module



Figure 114: SIMs WLAN Module to Typical DFS System



### ⚠ WARNING

High voltages capable of causing death are used in this equipment. Outdoor unit power remains connected during this procedure. Take extreme caution not to touch electrical components or connections. Failure to observe this warning can result in death or severe injury.

### Note:

- The Duct Free System air conditioning system must run for at least 15–20 minutes before data collected by SIMs 2.0 is valid for troubleshooting.
- You must have the free SIMs app correctly installed on your smart phone before using SIMs.
- Some ODUs have an LGMV extension cable accessed by removing the side handle cover. If the ODU does not have this extension cable, access the LGMV connector by removing the top cover of the ODU.

Figure 115: SIMs App Main Info Screen

### SIMs App Main Info Screen

The main screen is the first screen displayed after wireless connection is established. Tap the Main Info tab to display current readings regarding your indoor and outdoor unit(s). The Operational Info area of the screen will show active functions or modes by illuminating the light to the right of the function (Figure 115).

Additional Help information can be accessed by tapping the Help Menu buttons at the bottom of this screen.

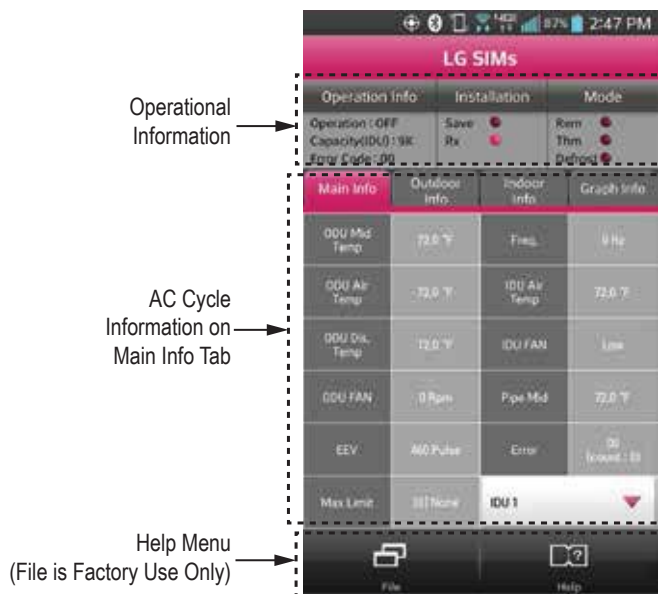



# ELECTRICAL WIRING

## LG SIMS - Self Diagnosis Functions

### SIMs App Screens



#### Outdoor Info/Component Screen

Displays the following information:

- Frequency
- FAN1 RPM
- FAN2 RPM
- DC Link
- Current
- Voltage
- EEV Mode
- Restart Timer
- Comp Mode
- EEV

#### Outdoor Info/Temperature Screen

Displays the following information:

- Inv TD
- Suction
- Discharge
- Cond Mid
- Cond Out
- Heatsink
- Air Temp



#### Indoor Info Tab

Displays the following information:

- Frequency
- Operation
- THM Mode
- REM Mode
- FAN
- EEV
- Air Temp
- Pipe-in
- Pipe-mid
- Pipe-out

#### Graph Info Tab

This tab, has three sub sections:

- IDU - Indoor Unit Temperature graph. Displays IDU information in graph format. Information displayed is for the IDU # selected on the Main screen.
- ODU - Outdoor Unit Temperature and Frequency graph. Displays ODU information in graph format.
- ODU Electric - Outdoor Unit Electric data graph is displayed.

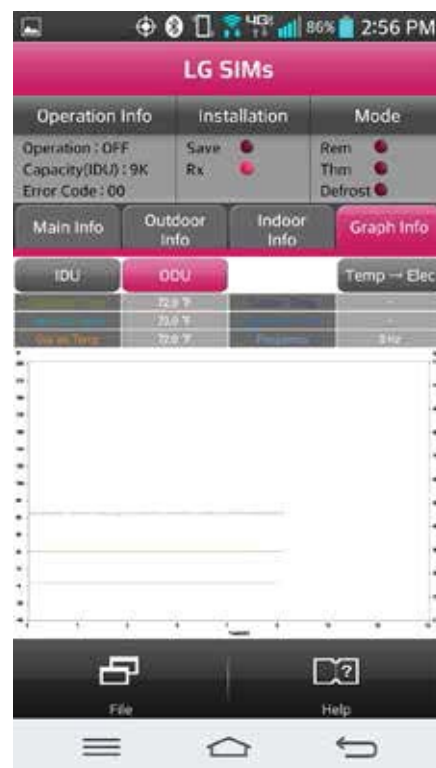

# TROUBLESHOOTING

## Error Codes

### Troubleshooting Using Error Codes

Refer to Table 35 and Table 36 for error codes that are generated from the indoor and outdoor units. These codes are the most common that will manifest through these units. Your particular model duct free system might generate additional codes not listed here. Please contact LG Support if you see these types of errors and a simple power down and boot up has not corrected the issue. You should not attempt to fix the system yourself.

#### Error Codes

- Refer to the figures below for your particular indoor unit's LED configuration.
- Indicate different types of unit failures, assists in self-diagnosis and to track the frequency of occurrence.

- Error codes are shown on the LEDs of indoor units, wired remote controller, the Single Zone unit control board, and LG Monitoring View (LGMV) Diagnostic Software.
- If two or more errors occur simultaneously, the lower error code number is displayed first.
- After error is resolved, the error code does not display.

#### Decoding the Error Display

The first and second number on the LED indicates error number. Example: 21 = LED1 (Green light) 2x blink, LED2 (Red light) 1x blink

#### Error Code Nomenclature Definitions

- MICOM: Non-volatile memory chip where unit setup information is stored.
- EPROM: Non-volatile memory chip where device identification, size, and factory defined default component operating parameters are stored.

Table 35: Single Zone Wall Mounted Indoor Unit Error Codes

Error Code	Description	No. of Times Indoor Unit LEDs Blink	
		LED1 (Plasma LED)	LED2 (Power LED)
1	Indoor unit room temperature sensor error	1X	-
2	Indoor unit inlet pipe sensor error	2X	-
4	Float switch error (optional)	4X	-
5	Communication error between indoor unit and outdoor units	-	5X
6	Indoor unit outlet pipe sensor error	6X	-
9	Indoor unit EPROM error	9X	-
10	Indoor unit BLDC motor fan lock	-	1X
12	Indoor unit middle pipe sensor error	2X	1X

Figure 116: IDU LS-HSV3 Models

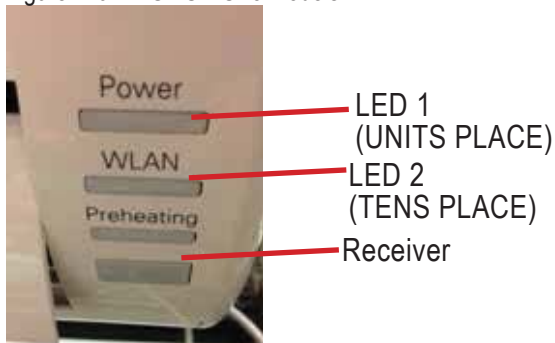

Figure 118: IDU LS-HV3/Some HSV Models

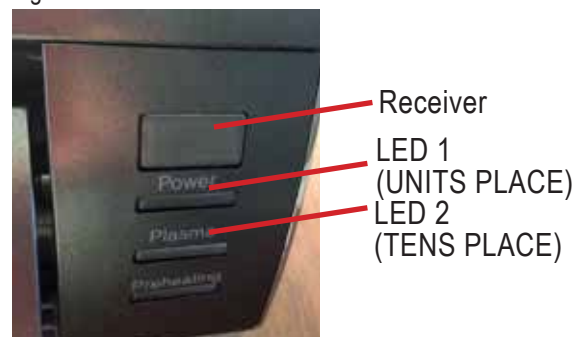

Figure 117: IDU Some HSV Models

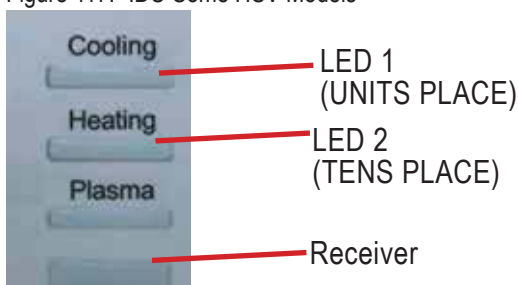
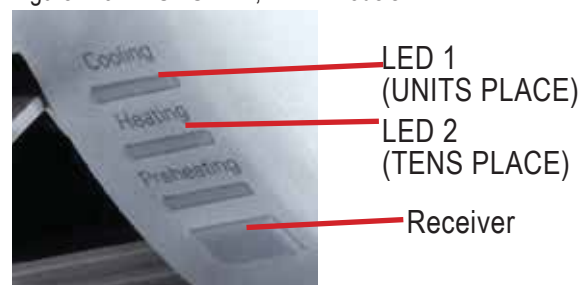

Figure 119: IDU LS-HEV, HEV1 Models



Due to our policy of continuous product innovation, some specifications may change without notification.  
©LG Electronics U.S.A., Inc., Englewood Cliffs, NJ. All rights reserved. "LG" is a registered trademark of LG Corp.



### Troubleshooting Using Error Codes - Continued

Table 35: Single Zone Wall Mounted Indoor Unit Error Codes - Continued

Error Code	Description	No. of Times Indoor Unit LEDs Blink	
		LED1 (Plasma LED)	LED2 (Power LED)
21	DC Peak (IPM Fault); Compressor DC voltage was too high	2X	1X
22	Current Transformer2 (CT2) error; Alternating current (AC) input too high	2X	2X
23	DC Link Low Volt	2X	3X
25	AC Low/High Volt	2X	5X
26	DC Comp Position Error (not providing rotation), Locking	2X	6X
27	PSC Fault; Current to inverter compressor between AC and DC converter circuit too high	2X	7X
28	Inverter compressor DC voltage is too high	2X	8X
29	Inverter compressor amperage is too high	2X	9X
31	Current-to-current transformer (CT) thermistor is too low	3X	1X
32	Inverter Compressor Discharge Pipe (D-Pipe) Overheat	3X	2X
40	CT Sensor Error; Thermistor is disconnected or shorted out	4X	-
41	D-Pipe Sensor INV is disconnected or shorted out	4X	1X
44	Outdoor Air Sensor is disconnected or shorted out	4X	4X
45	Middle thermistor of outdoor unit condenser coil is disconnected or shorted out	4X	5X
46	Outdoor unit suction line thermistor is disconnected or shorted out	4X	6X
48	Outdoor unit coil outlet (liquid line) thermistor is disconnected or shorted out	4X	8X
53	Communication failure from outdoor unit to indoor unit	5X	3X
60	Outdoor unit printed circuit board (PCB) EPROM check sum error	6X	-
61	Outdoor unit condenser coil temperature is too high	6X	1X
62	Outdoor unit inverter compressor PCB heat sink temperature is too high	6X	2X
63	Condenser coil pipe thermistor temperature is too low	6X	3X
65	Heat sink thermistor has disconnected or has shorted out	6X	5X
67	Outdoor brushless direct current (BLDC) fan motor lock error	6X	7X

Refer to Service Manuals posted on [www.lghvac.com](http://www.lghvac.com) for a full description of all error codes and work-arounds.

# TROUBLESHOOTING

## Error Codes

### Single Zone Wall Mounted Outdoor Unit Error Codes

The Single Zone Wall Mounted outdoor unit error codes are visible on the outdoor unit, as well as from the indoor unit. However, the indoor unit error codes are only visible from the indoor unit and will not display at the outdoor unit. When troubleshooting the system, be sure to verify if the error codes that are being displayed are specific for indoor or outdoor units.

Table 36: Single Zone Wall Mounted Outdoor Unit Error Codes

Error Code	Description	No. of Times Outdoor Unit LEDs Blink	
		LED1 (Plasma LED)	LED2 (Power LED)
21	DC Peak (IPM Fault); Compressor DC voltage was too high	2X	1X
22	Current Transformer2 (CT2) error; Alternating current (AC) input too high	2X	2X
23	DC Link Low Volt	2X	3X
25	AC Low/High Volt	2X	5X
26	DC Comp Position Error (not providing rotation), Locking	2X	6X
27	PSC Fault; Current to inverter compressor between AC and DC converter circuit too high	2X	7X
28	Inverter compressor DC voltage is too high	2X	8X
29	Inverter compressor amperage is too high	2X	9X
31	Current-to-current transformer (CT) thermistor is too low	3X	1X
32	Inverter Compressor Discharge Pipe (D-Pipe) Overheat	3X	2X
40	CT Sensor Error; Thermistor is disconnected or is shorted out	4X	-
41	D-Pipe Sensor INV is disconnected or shorted out	4X	1X
44	Outdoor Air Sensor is disconnected or shorted out	4X	4X
45	Middle thermistor of outdoor unit condenser coil is disconnected or shorted out	4X	5X
46	Outdoor unit suction line thermistor is disconnected or shorted out	4X	6X
48	Outdoor unit coil outlet (liquid line) thermistor is disconnected or shorted out	4X	8X
53	Communication failure from outdoor unit to indoor unit	5X	3X
60	Outdoor unit printed circuit board (PCB) EPROM check sum error	6X	-
61	Outdoor unit condenser coil temperature is too high	6X	1X
62	Outdoor unit inverter compressor PCB heat sink temperature is too high	6X	2X
63	Condenser coil pipe thermistor temperature is too low	6X	3X
65	Heat sink thermistor has disconnected or has shorted out	6X	5X
67	Outdoor brushless direct current (BLDC) fan motor lock error	6X	7X

Refer to Service Manuals posted on [www.lghvac.com](http://www.lghvac.com) for a full description of all error codes and work-arounds.

# CAUTIONS FOR REFRIGERANT LEAKS

## Refrigerant Leaks

### Cautions for Refrigerant Leaks / Introduction

ASHRAE Standards 15-2010 and 34-2010 offer guidelines that address refrigerant safety and the maximum allowable concentration of refrigerant in an occupied space. Refrigerant will dissipate into the atmosphere, but a certain volume of air is required for this to occur safely. For R410A refrigerant, the maximum allowable concentration is 0.026 lbs./ft<sup>3</sup> per 1,000 ft<sup>3</sup> of air in an occupied space. Buildings with twenty-four (24) hour occupancy allow half of that concentration.<sup>1</sup>

ASHRAE Standards 15 and 34 assume that if a system develops a leak, its entire refrigerant charge will dump into the area where the leak occurs. To meet ASHRAE Standards 15 and 34, calculate the refrigerant concentration that may occur in the smallest room volume on the system, and compare the results to the maximum allowable concentration number (see below for information on how to calculate the refrigerant concentration).<sup>1</sup> Also consult state and local codes in regards to refrigerant safety.

#### **⚠ WARNING**

Verify the maximum refrigerant concentration level in the space where the indoor unit will be mounted meets the concentration limit for the application. If the refrigerant leaks and safety limits are exceeded, it could result in personal injuries or death from oxygen depletion.

#### **Note:**

Take appropriate actions at the end of HVAC equipment life to recover, recycle, reclaim or destroy R410A refrigerant according to applicable US EPA rules.

To calculate the potential refrigerant concentration level (RCL):

1. Measure the occupied space dimensions (in feet).
2. Calculate the cubic foot volume of air in the smallest occupied space. (To obtain a detailed overview of the RCL, perform the same calculations to the second smallest zone, the third smallest zone until the RCL is obtained for all zones. Also, pay special attention to areas such as basements, etc., where refrigerant cannot dissipate easily.)
3. Divide the refrigerant charge of the Single Zone system serving the area in pounds by the results of step 1.
4. If the calculation indicates that the potential refrigerant concentration level is higher than the allowed RCL, increase the cubic volume of the smallest occupied space or modify the piping system design.
5. The allowable RCL limit for most applications must be equal to or less than 0.026 lbs./ft<sup>3</sup>. However, in special occupied spaces, such as hospitals and nursing homes, where occupants may have limited mobility, the allowable RCL limit is cut in half. See ASHRAE Standard 34-2007 and local codes for detailed information.<sup>1</sup>

#### Refrigerant Concentration Limit (RCL) Calculations

To calculate total refrigerant amount per system:

Amount of Factory-Charged Refrigerant per Outdoor Unit	+	Amount of Additional Refrigerant Trim Charge	=	Total System Refrigerant Charge
---	---	---	---	---------------------------------------

$$\text{RCL (lbs./ft}^3\text{)} = \frac{\text{Total System Refrigerant Charge (lbs.)}}{\text{Volume of Smallest Occupied Space (ft}^3\text{)}}$$

<sup>1</sup> American Society of Heating, Refrigeration and Air Conditioning Engineers, Inc. (ASHRAE). Atlanta, GA. ASHRAE, Inc. Information about ASHRAE Standard 15-2010 / 34-2010 and addenda current as of the date of this publication.

# INSTALLATION CHECKLIST

PAGE 1

## Major Component Rough-In

Description	Check
Single Zone unit was connected properly per local code and the product installation procedures.	
All literature and bagged accessories have been removed from the fan discharge.	
Indoor unit was installed, properly supported, and located indoors in a non-corrosive environment.	
Single Zone unit's gravity condensate drain line was connected and routed where it properly drains away or, if installed in a mechanical room, was connected and properly routed to a drain terminal.	

## Piping and Insulation

Description	Check
Copper	
Over 5/8 inches—Rigid ACR only.	
5/8 inches and under—Can use soft ACR.	
15% silver brazing material only.	
All refrigerant pipes and valves were insulated separately. Insulation butts up against the walls of the indoor units. No gaps or cracks. Insulation was not compressed at clamps and hangers.	

## Brazing Practices

Description	Check
Medical grade (there are 4 available) dry nitrogen for purging during brazing was used (constant 3 psi while brazing).	

## Installation

(For more information on any procedure, refer to the detail provided in the Indoor Unit Installation Manuals.)

## Refrigerant Piping

Description	Check
All pipe materials were properly stored, capped, and clean. All burrs were removed after cutting and pipe ends were reamed before brazing.	
During refrigerant pipe installation, for each segment of pipe, a record was made of the pipe length (including expansion loops, offsets, double-back sections), and sizes, as well as the quantity and type of elbows used.	
All long runs of straight pipe were provided with expansion loops.	
A torque wrench and backup wrench were used to tighten all flare connections.	
The back side of all flares were lubricated with a small drop of PVE refrigeration oil before tightening flare fittings.	
Ensure all field made flares are 45°. Use factory-supplied flare nuts only.	
Pipe segments were properly supported and all wall penetrations were sleeved.	
Pipe insulation was not compressed at any point.	
No oil traps, solenoid valves, sight glasses, filter driers, or any other unauthorized refrigerant specialties were present.	
Best practice including a minimum of 20" of straight pipe was installed between each elbow.	

# INSTALLATION CHECKLIST

PAGE 2

## Condensate Pump / Drain Installation Power Wire and Communications Cables

Description	Check
Power wiring was connected to a single phase 208-230V source or 115V (Mega 115 HXV models only).	
Ground wire was installed and properly terminated at the unit.	
The power supplied was clean with voltage fluctuations within specifications. ( $\pm 10\%$ of nameplate).	
Power wiring to the Single Zone outdoor unit was installed per all local electrical code requirements.	
Power wiring to the indoor unit was installed per all local electrical code requirements.	
LG-supplied cable was used between the indoor unit and its zone controller. No cables were spliced and no wire caps are present.	
Communication type RS-485-BUS type.	
Communications/power were a minimum of 18-AWG, four (4) conductor, stranded, shielded or unshielded, with insulation material per local code. If shielded, must be ground to ODU only. Cable segment shields were tied together.	
Used appropriate crimping tool to attach ring or spade terminals at all power wiring and control cable terminations.	
Power and control wires were run in the same conduit (ODU to IDU only) as provided in the product installation manual. Power to ODU and power/communications to IDU cannot be run in the same conduit.	

For further technical materials such as submittals, engineering manuals, service manuals, and catalogs, visit [www.lghvac.com](http://www.lghvac.com).

*Inverter*



LG Electronics, U.S.A., Inc.  
Commercial Air Conditioning Division  
4300 North Point Parkway  
Alpharetta, Georgia 30022  
www.lg-vrf.com

LG Customer Information Center, Commercial Products  
1-888-865-3026 USA  
Follow the prompts for commercial A/C products.

IM\_WallMounted\_All\_11\_15  
Supersedes IM\_WallMounted\_All\_08\_15  
IM-WallMounted-All-08-14.1