

Job Name/Location:

Tag #:

Date:

For:	File	Resubmit
	Approval	Other _____

PO No.:

Architect:

GC:

Engr:

Mech:

Rep:
(Company)

(Project Manager)



LS120HEV2 Single Zone Mega Wall Mount

Outdoor Unit (ODU) - LSU120HEV2, Indoor Unit (IDU) - LSN120HEV2

Performance:

Cooling:

Cooling Capacity (Min~Rated~Max) (Btu/h)	3,070 ~ 12,000 ~ 13,780
SEER	19.00
EER	10.51

SEER - Seasonal Energy Efficiency Ratio EER - Energy Efficiency Ratio

Heating:

Heating Capacity (Min~Rated~Max) (Btu/h)	3,070 ~ 12,000 ~ 13,780
Max. Heating @ Indoor 70°F DB Outdoor 19°F DB / 17°F WB	9.640
HSPF	9.5

HSPF - Heating Seasonal Performance Factor
Cooling Nominal Test Conditions: Indoor: 80°F DB / 67°F WB Heating Nominal Test Conditions: Indoor: 70°F DB / 60°F WB
Outdoor: 95°F DB / 75°F WB Outdoor: 47°F DB / 43°F WB

Electrical:

Power Supply (V~/Hz/Ø)	208-230/60/1
------------------------	--------------

Outdoor Unit:

MOP (A)	15
MCA (A)	10
Cooling Rated Amps (A)	7.4
Heating Rated Amps (A)	7.4
Compressor (A)	7.0
Fan Motor (A)	0.4

MOP - Maximum Overcurrent Protection MCA - Minimum Circuit Ampacity

Total Power Input:

Cooling Power Input (kW)	1.142
Heating Power Input (kW)	1

Piping:

Liquid Line (in., O.D.)	1/4
Vapor Line (in., O.D.)	3/8
Additional Refrigerant (oz./ft.)	0.22
Min. / Max. Pipe Length (ft.) ²	9.8 / 49.2
Piping Length (no add'l refriger., ft.)	24.6
Max. Elevation (ft.)	23

Features:

- 24-Hour on/off timer
- 2-Way (up / down) auto swing
- Auto changeover
- Auto restart
- Jet cool/Jet heat
- Condensate sensor connection
- Energy saving
- Inverter (variable speed compressor)
- Self-cleaning indoor coil
- Sleep mode
- Ultra quiet operation

Included Accessories:

- Wireless Remote Controller — AKB74955602

Optional Accessories:¹⁰

- MultiSITE™ CRUC1 — PREMTBVC0
- MultiSITE CRC1+ — PREMTBVC1
- Simple Remote Controller — PREMTCC00
- Premium Remote Controller — PREMTA000

For a complete list of available accessories, contact your LG representative.
For continual product development, LG reserves the right to change specifications without notice.
© LG Electronics U.S.A., Inc., Englewood Cliffs, NJ. All rights reserved. "LG Life's Good" is a registered trademark of LG Corp. /www.lghvac.com

Operating Range:

Outdoor Unit:

Cooling (°F DB)	14 ~ 118
Heating (°F WB)	14 ~ 65

Indoor Unit:

Cooling (°F WB)	53 ~ 75
Heating (°F DB)	60 ~ 86

System Data:

Refrigerant Type	R410A
Refrigerant Control	EEV
Refrigerant Charge (lbs.)	1.875
ODU Sound Pressure (Cooling / Heating) (±1 dB[A]) ³	50 / 50
IDU Sound Pressure Cooling (H/M/L/Sleep) (±1 dB[A]) ³	42 / 36 / 28 / 21
Heating (H/M/L) (±1 dB[A]) ³	42 / 36 / 28
ODU Net / Shipping Weight (lbs.)	55.3 / 60
IDU Net / Shipping Weight (lbs.)	19.2 / 25.4
Heat Exchanger Coating	GoldFin™

Fan:

ODU Type	Propeller
IDU Type	Cross Flow
Fan Speeds (Fan/Cool/Heat)	6 / 6 / 6
Quantity (ODU + IDU)	1 + 1
Motor/Drive	Brushless Digitally Controlled/Direct
ODU Max. Air Flow Rate (CFM)	953
IDU Air Flow Cooling, Max/H/M/L (CFM)	459 / 353 / 264 / 148
Heating, Max/H/M/L (CFM)	459 / 353 / 254 / 198
Dehumidification (pts./hr.)	2.75

Notes:

1. Acceptable operating voltage: 187V-253V.
2. Piping lengths are equivalent.
3. Sound Pressure levels are tested in an anechoic chamber under ISO Standard 3745.
4. All communication / connection (power) cable from the outdoor unit to the indoor unit is field supplied and must be a minimum of four-conductor, 14 AWG, stranded, shielded or unshielded (if shielded, it must be grounded to the chassis of the outdoor unit only), and must comply with applicable local and national codes.
5. See Engineering Manual for sensible and latent capacities.
6. Power wiring cable size must comply with the applicable local and national code.
7. The indoor unit comes with a dry helium charge.
8. This data is rated 0 ft. above sea level, with 24.6 ft. of refrigerant line and a 0 ft. level difference between outdoor and indoor units.
9. Must follow installation instructions in the applicable LG installation manual.
10. LSN***HEV2 9,000 and 12,000 Btu/h Mega indoor units are compatible with wired controllers from July 2019 production; LSN***HEV2 18,000 and 24,000 Btu/h Mega indoor units are compatible with wired controllers from January 22, 2020 production.



LS120HEV2
 Single Zone Mega Wall Mount
 Outdoor Unit (ODU) - LSU120HEV2, Indoor Unit (IDU) - LSN120HEV2



Tag No.: _____

Date: _____

PO No.: _____

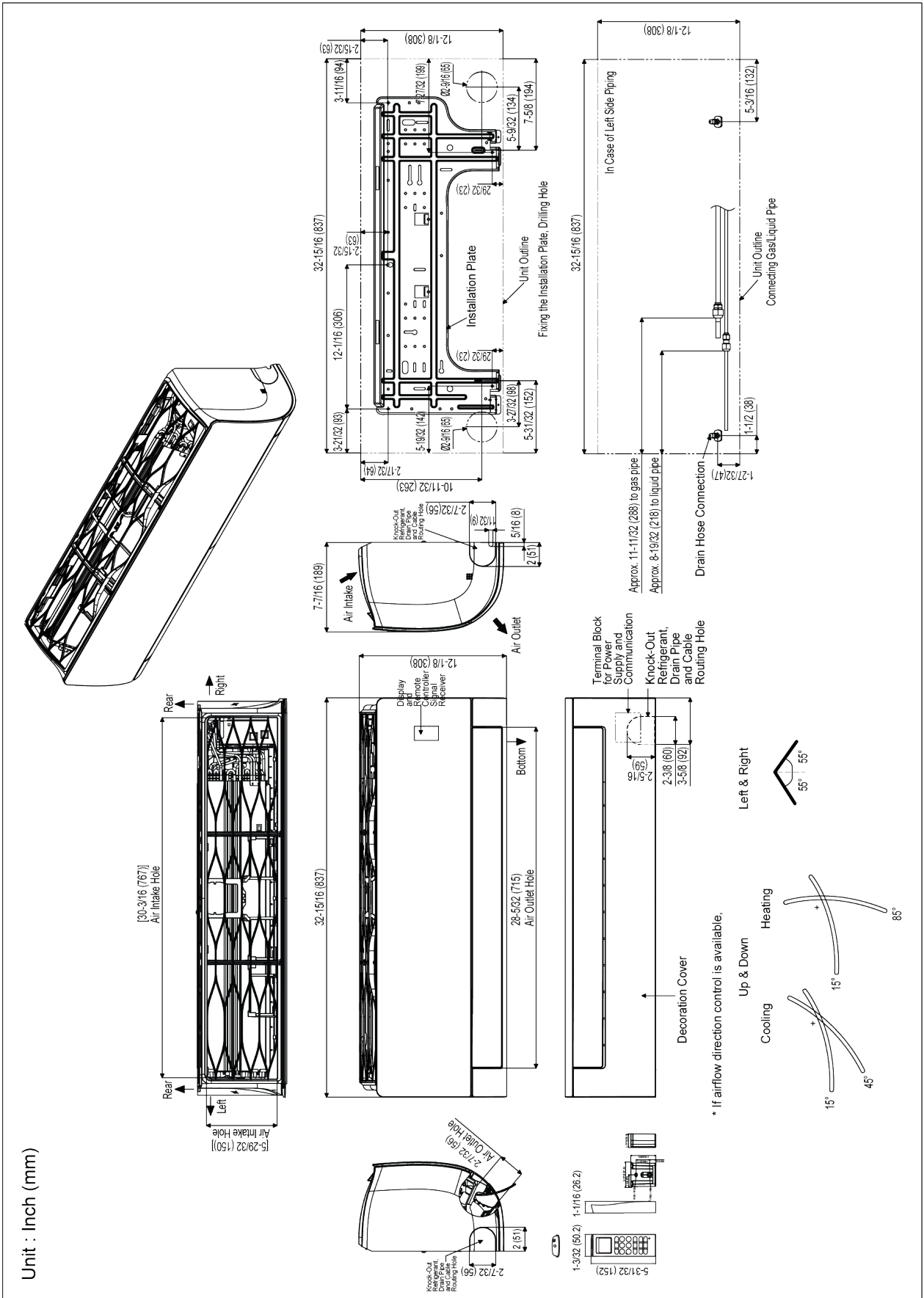

LS120HEV2

Single Zone Mega Wall Mount

Outdoor Unit (ODU) - LSU120HEV2, Indoor Unit (IDU) - LSN120HEV2



Tag No.: _____

Date: _____

PO No.: _____

