

Job Name/Location:

Tag No:

Date:

For:	File	Resubmit
	Approval	Other

PO No.:

Architect: GC:

Engr: Mech:

Rep: (Company) (Project Manager)



LMU541HV Multi F MAX Outdoor Unit 4.5 Ton Heat Pump

Performance:

Cooling Capacity (Min.-Rated-Max., Btu/h)	10,800-50,500-63,200
Heating Capacity (Min.-Rated-Max., Btu/h)	12,420-58,000-64,000
Max. Heating Capacity at 17°F (Btu/h)	49,530
Max. Heating Capacity at 5°F (Btu/h)	41,140
Max. Heating Capacity at -4°F (Btu/h)	35,790
Cooling COP @95°F (Rated)	3.69
Heating COP @47°F (Rated)	3.35

Cooling Nominal Test Conditions:
Indoor: 80°F DB / 67°F WB
Outdoor: 95°F DB / 75°F WB

Heating Nominal Test Conditions:
Indoor: 70°F DB / 60°F WB
Outdoor: 47°F DB / 43°F WB

Electrical:

Power Supply (V/Hz/Ø) ¹	208-230V, 60, 1
MOP (A)	40
MCA (A)	32.7
Cooling Rated Amps (A)	30.0
Heating Rated Amps (A)	30.0
Compressor (A)	22.0
Fan Motor (A)	1.6 x 2
Locked Rotor Amps (A)	22

MOP - Maximum Overcurrent Protection

MCA - Minimum Circuit Ampacity

Piping:

Refrigerant Charge (lbs.)	9.26
Liquid Line Connection (in., O.D.)	Ø3/8 x 1
Vapor Line Connection (in., O.D.)	Ø3/4 x 1
Maximum Total Piping ² (ft.)	475.7
Min. / Max. ODU to IDU Piping ³ (ft.)	32.8 / 229.6
Piping Length ⁴ (no add'l refrigerant, ft.)	180.4
Maximum Elevation between ODU and IDU (ft.)	98.4
Maximum Elevation between IDU and IDU (ft.)	49.2

ODU = Outdoor Unit

IDU = Indoor Unit

Features:

- R1 Scroll (Variable Speed) Compressor
- Auto operation
- Auto restart
- Self diagnosis
- Defrost / Deicing
- Low ambient cooling down to 14°F
- Soft start
- Restart delay (three [3] minutes)

Optional Accessories:

- PI-485 - PMNFP14A1
- AC Smart 5 - PACS5A000
- ACP 5 - PACP5A000
- MultiSITE™ Comm. Mgr. - PBACNBTR0A
- Power Distribution Indicator (PDI) Premium - PQNUD1S41
- Mobile LGMV - PLGMVW100
- Low Ambient Wind Baffle (Cooling Operation Down to -4°F) - ZLABGP04A x2
- Drain Pan Heater - PQSH1200

Required⁵ Accessories:

- 2 Port BD Unit - PMBD3620
- 3 Port BD Unit - PMBD3630
- 4 Port BD Unit - PMBD3640
- 4 Port BD Unit - PMBD3641

Operating Range:

Cooling (°F DB) ¹⁵	14 to 118
Heating (°F WB)	-4 to +64

Unit Data:

Refrigerant Type	R410A
Refrigerant Control	EEV
Sound Pressure (Cool / Heat) ±1 dB(A) ⁶	53 / 55
Net / Shipping Weight (lbs.)	192 / 216
Heat Exchanger Coating	Gold Fin™
Minimum No. of Indoor Units	2
Maximum No. of Indoor Units	8

Compressor:

Type	R1 Scroll
Quantity	1
Oil / Type	FVC68D

Fan:

Type	Propeller
Quantity	2
Motor / Drive	Brushless Digitally Controlled/Direct
Max. Airflow Rate (CFM)	1,942 x 2

Notes:

1. Acceptable operating voltage: 187V - 253V.
2. Piping lengths are equivalent.
3. 180.4 ft. of Main Piping + 49.2 ft. of Branch Piping.
4. 49.2 ft. of Main Piping + 131.2 of Branch Piping.
5. At least one branch distribution (BD) unit is required for system operation; a maximum of two can be installed per ODU with the use of a Y-branch accessory (PMBL5620).
6. Sound pressure levels are tested in an anechoic chamber under ISO Standard 3745.
7. All power / communication cable to be minimum 14 AWG from the ODU to the BD unit, and 14 AWG from the BD unit to the IDU.
8. All power / communication cable to be 4-conductor, stranded, shielded or unshielded, and must comply with applicable local and national codes. If shielded, the wire must be grounded to the chassis at the ODU only.
9. Power wiring size must comply with the applicable local and national codes.
10. See the Engineering Manual Capacity Tables for ODU sensible and latent capacities.
11. See the Engineering Manual Combination Tables for allocation of ODU rated capacity to each connected IDU when all are calling for full capacity. Allocation percentages should be applied to ODU capacity at design conditions.
12. This data is rated 0 ft. above sea level, with 115 ft. of refrigerant line, and 0 ft. level difference between ODU and IDUs. All capacities are net with a combination ratio between 95 - 105%.
13. Must follow installation instructions in the applicable LG installation manual.
14. See the Engineering Manual Capacity Tables for ODU capacity at design conditions.
15. Installation of an optional Low Ambient Wind Baffle Kit will allow operation down to -4°F in cooling mode.



For a complete list of available accessories, contact your LG representative.

For continual product development, LG reserves the right to change specifications without notice.

© LG Electronics U.S.A., Inc., Englewood Cliffs, NJ. All rights reserved. "LG Life's Good" is a registered trademark of LG Corp. /www.lghvac.com

SB_MultiF_MAX_LMU541HV_2021_09_08_125816

Job Name/Location: _____

LMU541HV
Multi F MAX Outdoor Unit
4.5 Ton Heat Pump



Tag No.: _____

Date: _____

PO No.: _____

[Unit: inch]

Chassis code : U60A

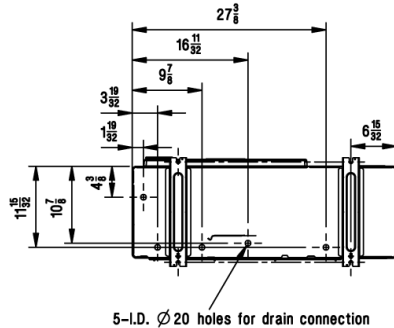
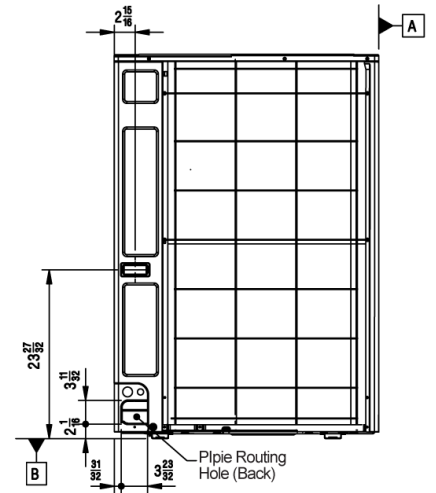
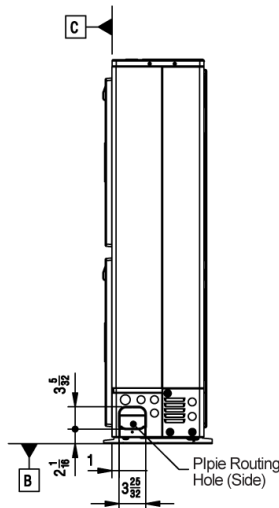
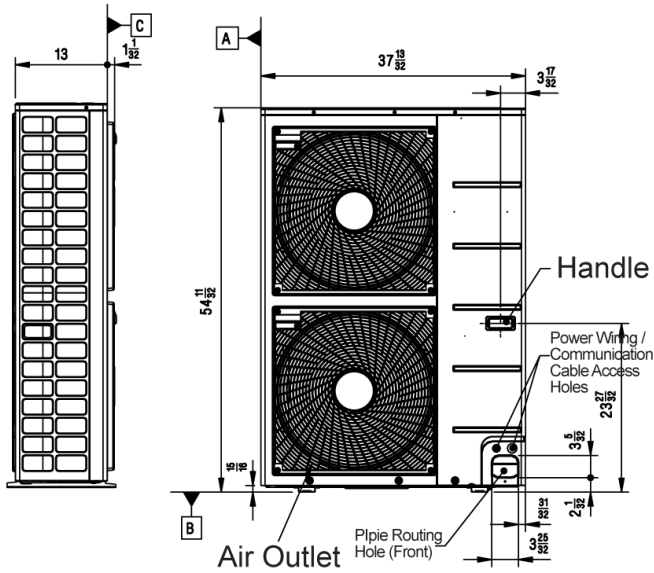
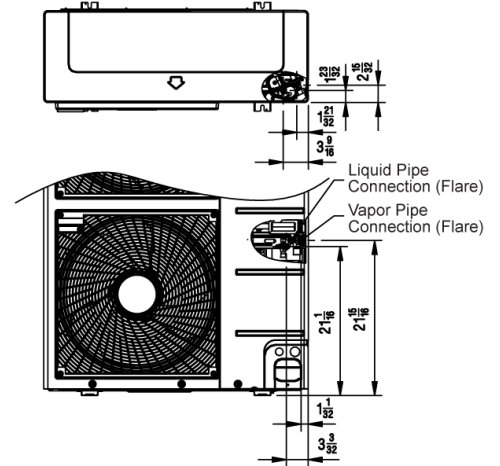
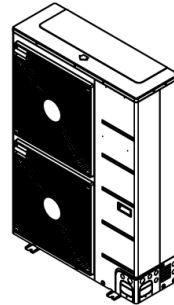
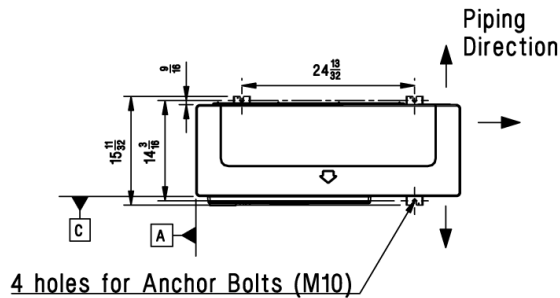

Symbols

- Piping Direction
- └─ A ─┘ Datum line

Notes:

1. Unit must be installed in compliance with the installation manual.
2. Unit must be grounded in accordance with the local or state regulations and applicable national codes.
3. All field-supplied electrical components and materials must comply with local, state, and national codes.
4. Electrical characteristics must be considered for electrical work and design. The capacity of power cable and circuit breaker for the outdoor unit must follow local, state, national, and manufacturer requirements.

Job Name/Location: _____

LMU541HV
Multi F MAX Outdoor Unit
4.5 Ton Heat Pump



Tag No.: _____

Date: _____

PO No.: _____

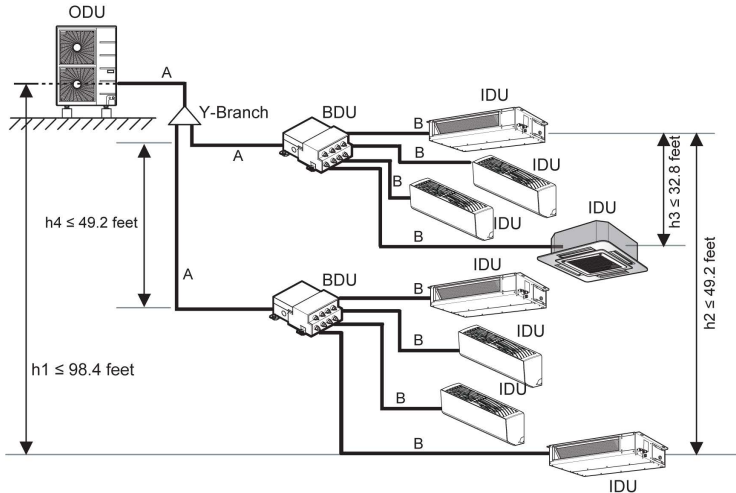

Example: outdoor unit with eight (8) indoor units and two (2) branch distribution units connected.
 ODU: Outdoor Unit.
 IDU: Indoor Unit.
 BDU: Branch Distribution Unit(s).
 A: Main Pipe.
 B: Branch Pipe (Branch Distribution Unit[s] to Indoor Unit[s]).

Multi F MAX Outdoor Unit Refrigerant Piping System Limitations.

Pipe Length (ELF = Equivalent Length of pipe in Feet)	Total piping length ($\Sigma A + \Sigma B$)	≤475.7 feet	
	Main pipe (Outdoor Unit to Branch Distribution Units: A)	Minimum for Each (A) Piping Segment	16.4 feet
		Maximum (ΣA)	≤180.4 feet
	Total branch piping length (ΣB)	≤295.3 feet	
Elevation Differential (All Elevation Limitations are Measured in Actual Feet)	Branch pipe (Branch Distribution Units to Indoor Units: B)	Minimum	16.4 feet
		Maximum	≤49.2 feet
	If outdoor unit is above or below indoor unit (h1)		≤98.4 feet
	Between the farthest two indoor units (h2)		≤49.2 feet
Between branch distribution unit and farthest connected indoor unit(s) (h3)		≤32.8 feet	
Between branch distribution units (h4)		≤49.2 feet	

Installing the Unit

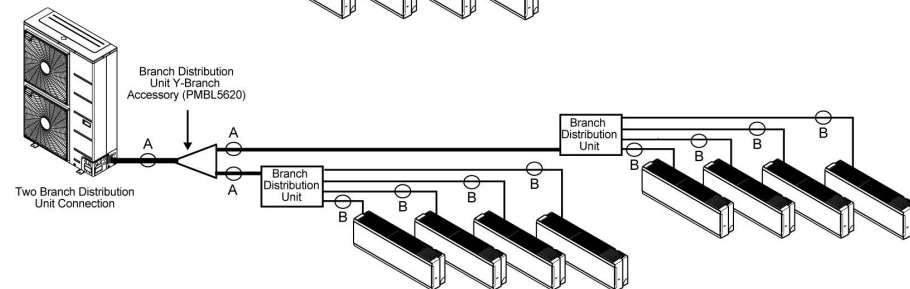
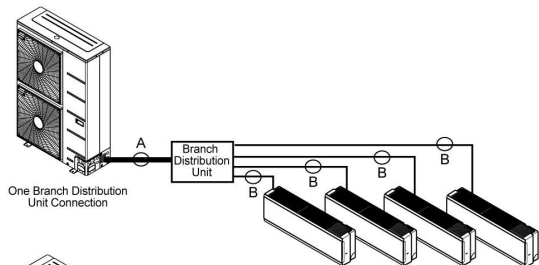

Multi F MAX Piping Sizes.

Piping	Main Pipe A (inch)	Branch Pipe B
Liquid	Ø3/8	Depends on the size of the indoor unit piping.
Vapor	Ø3/4	

Date:

For: File Resubmit

PO No.:

 Approval Other _____

Architect:

GC:

Engr:

Mech:

Rep:

(Company)

(Project Manager)

PMBD3630**3-Port Branch Distribution Unit (BD Unit)****Performance:**

Max Nominal Port Capacity Btu/h (each port)	24,000
Max Nominal Unit Capacity Btu/h (sum of ports)	72,000
Power Input (W)	24

Electrical:

Power Supply (V ¹ /Hz/∅)	208-230/60/1
Rated Amps (A)	0.12

Piping:**Piping Connection to Outdoor Unit:**

Liquid Line (in, OD)	3/8
Vapor Line (in, OD)	3/4

Piping Connection to Indoor Unit:

Liquid Line (in, OD)	1/4 (Qty 3)
Vapor Line (in, OD)	3/8 (Qty 3)

Standard Features:

- Distributes refrigerant to indoor units
- Internal components are insulated
- Flare joints provided for easy installation
- Compact design

Operating Range:

Operating Range (°F DB)	0-150
-------------------------	-------

Unit Data:

Net Weight (lbs)	15
Shipping Weight (lbs)	17

Notes:

1. Acceptable operating voltage: 187V-253V.
2. All power/communication cable to be minimum 16 AWG from the outdoor unit to the BD unit and 18 AWG from the BD unit to the indoor unit.
3. All power/communication cable to be 4-conductor, stranded, shielded and must comply with applicable local and national code.
4. Piping lengths:
 - Maximum height difference between BD unit and indoor units - 32.8 ft
 - Maximum height difference between BD unit and BD unit - 49.2 ft.
 - Maximum piping length between BD unit and indoor units - 49.2 ft
5. The BD unit should be installed inside of a building.
6. Must follow installation instructions in the applicable LG installation manual.
7. Power wiring cable size must comply with the applicable local and national code.

PMBD3630

3-Port Branch Distribution Unit (BD Unit)



Tag #:

Date:

PO No.:

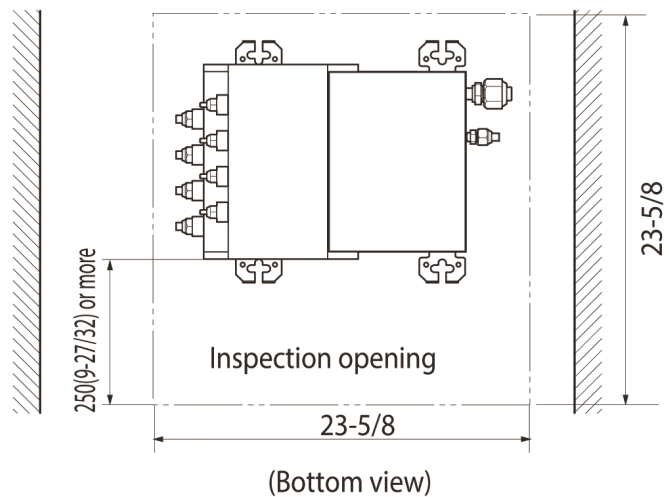
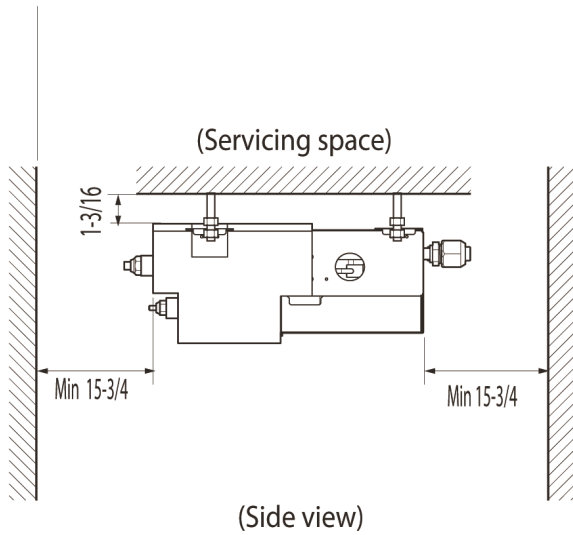
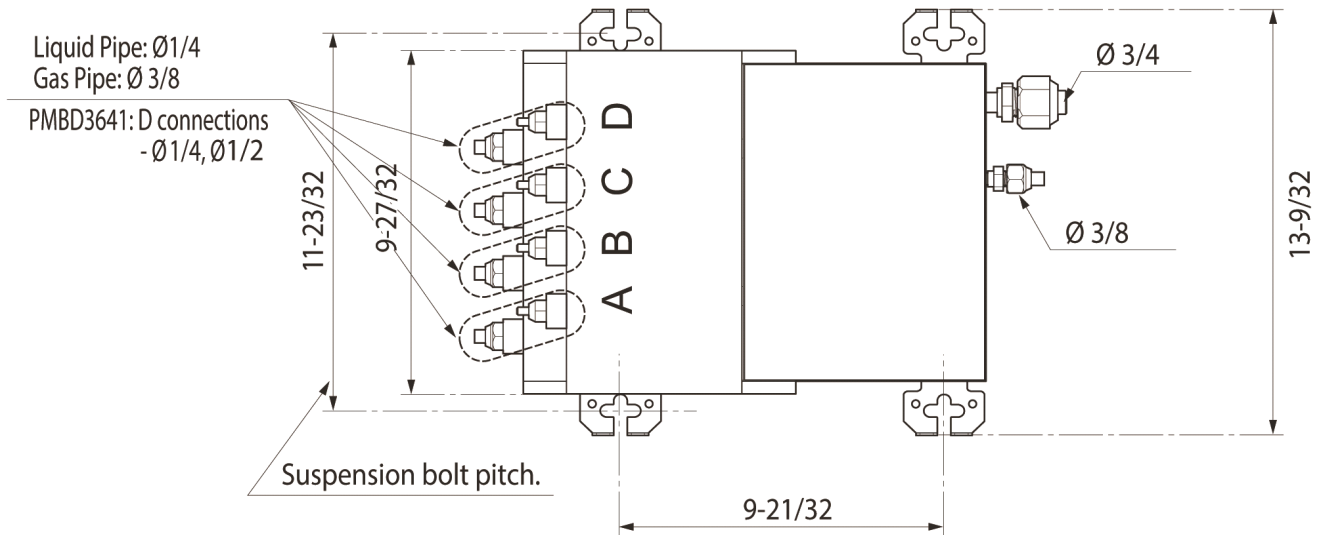
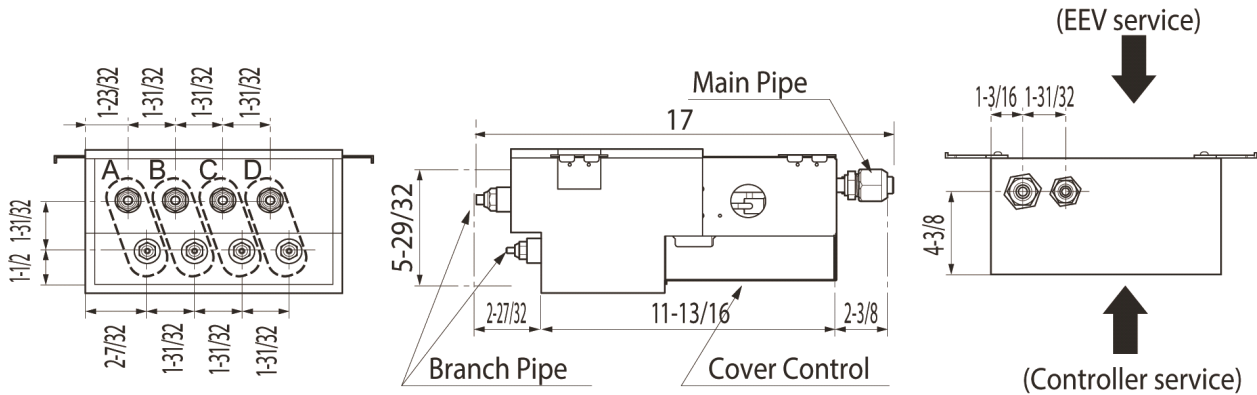

Notes

1. For PMBD3620 unit, ports A and B are available.
2. For PMBD3630 unit, ports A, B and C are available.
3. For PMBD3640 and PMBD3641 units, ports A, B, C and D are available.

Unit : inch

Job Name/Location:

Tag #:

Date:

For:	File	Resubmit
	Approval	Other_____

PO No.:

Architect: GC:

Engr: Mech:

Rep: (Company) (Project Manager)



LMN159HVT
Multi F Wall Mounted High Efficiency Indoor Unit
14,300 Btu/h



Performance:

Nominal Cooling Capacity (Btu/h)	14,300
Nominal Heating Capacity (Btu/h)	15,600

Cooling Nominal Test Conditions:
Indoor: 80°F DB / 67°F WB
Outdoor: 95°F DB / 75°F WB

Heating Nominal Test Conditions:
Indoor: 70°F DB / 60°F WB
Outdoor: 47°F DB / 43°F WB

Electrical:

Power Supply (V)/Hz/Ø	208-230/60/1
Rated Amps (A)	0.4

Piping:

Installed Liquid Pipe (in., O.D.)	Ø1/4
Installed Vapor Pipe (in., O.D.)	Ø3/8
Liquid Connection (in., O.D.)	Ø1/4
Vapor Connection (in., O.D.)	Ø3/8
Drain (in., O.D. / I.D.)	27/32 , 5/8
Temperature Sensor	Thermistor

Controls Features:

- 4-Way auto swing
- 24-Hour on/off timer
- Auto operation
- Auto restart
- Chaos wind
- Inverter (variable speed fan)
- Jet cool/Jet heat
- 3M Micro Dust Filter
- Self-cleaning indoor coil
- Sleep mode
- Condensate sensor connection
- Built-in Wi-Fi via Smart ThinQ app

Included Accessories:

- Wireless Remote Controller — AKB74955602

Optional Accessories:

- MultiSITE™ CRC1 - PREMTBVCO
- MultiSITE CRC1+ - PREMTBVC1
- Dry Contact - PDRYCB300

Entering Mixed Air:

Cooling (°F DB)	57 ~ 77
Heating (°F WB)	59 ~ 81

Unit Data:

Refrigerant Type	R410A
Refrigerant Control	EEV
Sound Pressure (H/M/L) (±3 dB[A]) ²	42 / 38 / 32
Primary Filter	Washable Pre-filter
Secondary Filter	3M Micro Dust
Net Weight (lbs.)	18.3
Shipping Weight (lbs.)	23.4

Fan:

Type	Cross Flow
Quantity	1
Motor/Drive	Brushless Digitally Controlled/Direct
Air Flow H/M/L (CFM)	314 / 268 / 184

Notes:

1. Acceptable operating voltage: 187V-253V.
2. Sound Pressure levels are tested in an anechoic chamber under ISO Standard 3745.
3. See Engineering Manual for sensible and latent capacities.
4. All communication / connection (power) cable from the outdoor unit to the indoor unit is field supplied and must be a minimum of four-conductor, 18 AWG, stranded, shielded or unshielded (if shielded, it must be grounded to the chassis of the outdoor unit only), and must comply with applicable local and national codes.
5. Power wiring cable size must comply with the applicable local and national code.
6. The indoor unit comes with a dry helium charge.
7. Corresponding refrigerant piping length is in accordance with standard length of each outdoor unit and the level difference is 0 ft. All capacities are net with a combination ratio between 95 - 105%.
8. Must follow installation instructions in the applicable LG installation manual.



LMN159HVT
Multi F Wall Mounted High Efficiency Indoor Unit
 14,300 Btu/h



Tag No.: _____

Date: _____

PO No.: _____

Unit : Inch (mm)

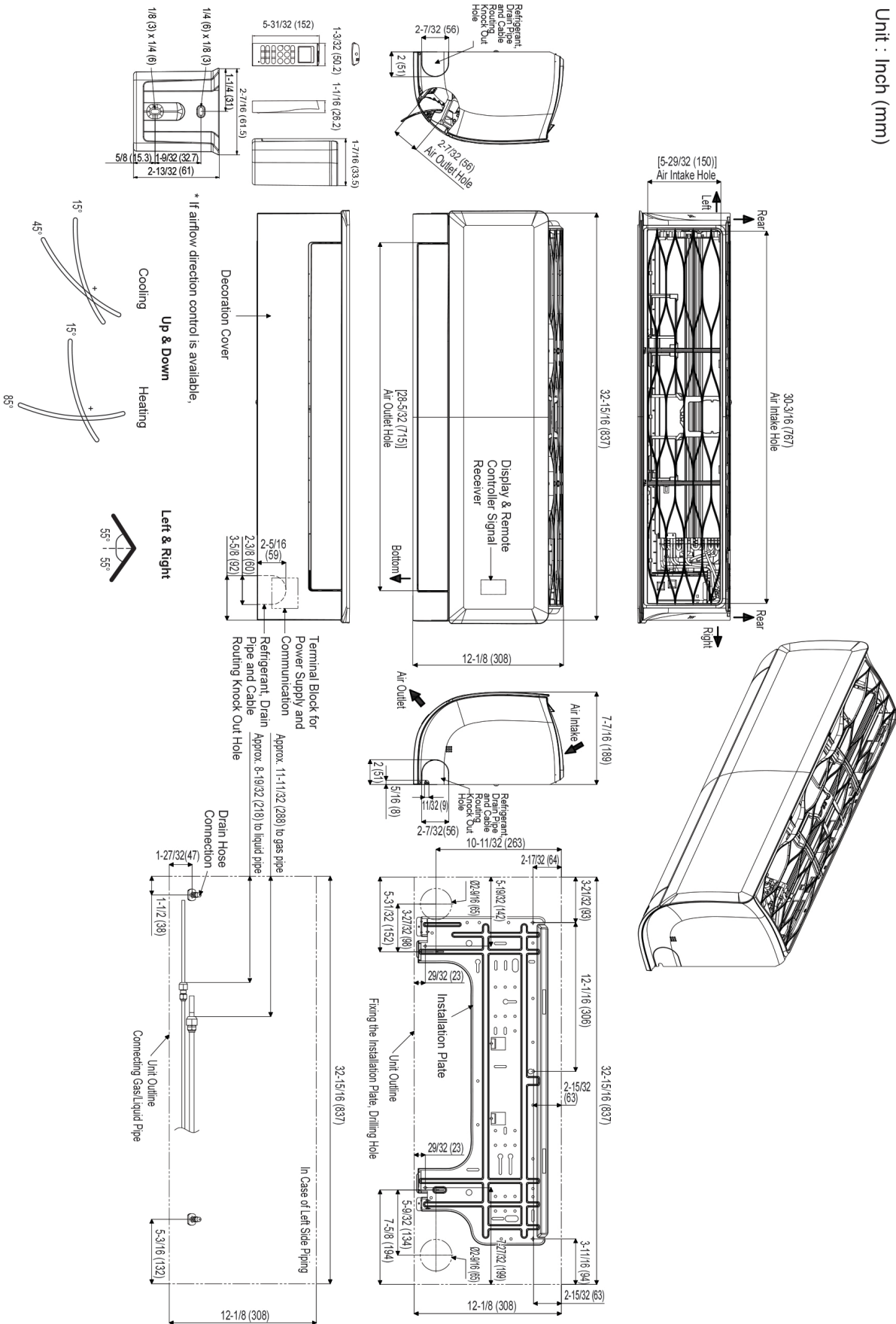

Job Name/Location:

Tag #:

Date:

For:	File	Resubmit
	Approval	Other_____

PO No.:



Architect: GC:

Engr: Mech:

Rep: (Company) (Project Manager)

LMN159HVT
Multi F Wall Mounted High Efficiency Indoor Unit
 14,300 Btu/h



Performance:

Nominal Cooling Capacity (Btu/h)	14,300
Nominal Heating Capacity (Btu/h)	15,600

Cooling Nominal Test Conditions:
 Indoor: 80°F DB / 67°F WB
 Outdoor: 95°F DB / 75°F WB

Heating Nominal Test Conditions:
 Indoor: 70°F DB / 60°F WB
 Outdoor: 47°F DB / 43°F WB

Electrical:

Power Supply (V)/Hz/Ø	208-230/60/1
Rated Amps (A)	0.4

Piping:

Installed Liquid Pipe (in., O.D.)	Ø1/4
Installed Vapor Pipe (in., O.D.)	Ø3/8
Liquid Connection (in., O.D.)	Ø1/4
Vapor Connection (in., O.D.)	Ø3/8
Drain (in., O.D. / I.D.)	27/32 , 5/8
Temperature Sensor	Thermistor

Controls Features:

- 4-Way auto swing
- 24-Hour on/off timer
- Auto operation
- Auto restart
- Chaos wind
- Inverter (variable speed fan)
- Jet cool/Jet heat
- 3M Micro Dust Filter
- Self-cleaning indoor coil
- Sleep mode
- Condensate sensor connection
- Built-in Wi-Fi via Smart ThinQ app

Included Accessories:

- Wireless Remote Controller — AKB74955602

Optional Accessories:

- MultiSITE™ CRC1 - PREMTBVCO
- MultiSITE CRC1+ - PREMTBVC1
- Dry Contact - PDRYCB300

Entering Mixed Air:

Cooling (°F DB)	57 ~ 77
Heating (°F WB)	59 ~ 81

Unit Data:

Refrigerant Type	R410A
Refrigerant Control	EEV
Sound Pressure (H/M/L) (±3 dB[A]) ²	42 / 38 / 32
Primary Filter	Washable Pre-filter
Secondary Filter	3M Micro Dust
Net Weight (lbs.)	18.3
Shipping Weight (lbs.)	23.4

Fan:

Type	Cross Flow
Quantity	1
Motor/Drive	Brushless Digitally Controlled/Direct
Air Flow H/M/L (CFM)	314 / 268 / 184

Notes:

1. Acceptable operating voltage: 187V-253V.
2. Sound Pressure levels are tested in an anechoic chamber under ISO Standard 3745.
3. See Engineering Manual for sensible and latent capacities.
4. All communication / connection (power) cable from the outdoor unit to the indoor unit is field supplied and must be a minimum of four-conductor, 18 AWG, stranded, shielded or unshielded (if shielded, it must be grounded to the chassis of the outdoor unit only), and must comply with applicable local and national codes.
5. Power wiring cable size must comply with the applicable local and national code.
6. The indoor unit comes with a dry helium charge.
7. Corresponding refrigerant piping length is in accordance with standard length of each outdoor unit and the level difference is 0 ft. All capacities are net with a combination ratio between 95 - 105%.
8. Must follow installation instructions in the applicable LG installation manual.



Job Name/Location:

Tag #:

Date:

For:	File	Resubmit
	Approval	Other_____

PO No.:

Architect: GC:

Engr: Mech:

Rep: (Company) (Project Manager)



LSN181HSV5
Multi F Wall Mounted High Efficiency Indoor Unit
18,000 Btu/h



Performance:

Nominal Cooling Capacity (Btu/h)	18,000
Nominal Heating Capacity (Btu/h)	21,600

Cooling Nominal Test Conditions:
Indoor: 80°F DB / 67°F WB
Outdoor: 95°F DB / 75°F WB

Heating Nominal Test Conditions:
Indoor: 70°F DB / 60°F WB
Outdoor: 47°F DB / 43°F WB

Electrical:

Power Supply (V/Hz/Ø)	208-230/60/1
Rated Amps (A)	0.4

Piping:

Installed Liquid Pipe (in., O.D.)	Ø1/4
Installed Vapor Pipe (in., O.D.)	Ø1/2
Liquid Connection (in., O.D.)	Ø3/8
Vapor Connection (in., O.D.)	Ø5/8
Drain (in., O.D. / I.D.)	27/32, 5/8
Temperature Sensor	Thermistor

Controls Features:

- 4-Way auto swing
- 24-Hour on/off timer
- Auto operation
- Auto restart
- Chaos wind
- Inverter (variable speed fan)
- Compatible with Single Zone HSV5 Outdoor Units
- Jet cool/Jet heat
- 3M Micro Dust Filter
- Self-cleaning indoor coil
- Sleep mode
- Condensate sensor connection
- Built-in Wi-Fi via Smart ThinQ app

Included Accessories:

- Wireless Remote Controller — AKB74955602

Optional Accessories:

- MultiSITE™ CRC1 - PREMTBVC0
- MultiSITE CRC1+ - PREMTBVC1
- Dry Contact - PDRYCB300

Entering Mixed Air:

Cooling (°F WB)	57 ~ 77
Heating (°F DB)	59 ~ 81

Unit Data:

Refrigerant Type	R410A
Refrigerant Control	EEV
Sound Pressure (H/M/L) (±3 dB[A]) ²	44 / 38 / 34
Primary Filter	Washable Pre-filter
Secondary Filter	3M Micro Dust
Net Weight (lbs.)	25.6
Shipping Weight (lbs.)	32.2

Fan:

Type	Cross Flow
Quantity	1
Motor/Drive	Brushless Digitally Controlled/Direct
Air Flow H/M/L (CFM)	558 / 438 / 353

Notes:

1. Acceptable operating voltage: 187V-253V.
2. Sound Pressure levels are tested in an anechoic chamber under ISO Standard 3745.
3. See Engineering Manual for sensible and latent capacities.
4. All communication / connection (power) cable from the outdoor unit to the indoor unit is field supplied and must be a minimum of four-conductor, 18 AWG, stranded, shielded or unshielded (if shielded, it must be grounded to the chassis of the outdoor unit only), and must comply with applicable local and national codes.
5. Power wiring cable size must comply with the applicable local and national code.
6. The indoor unit comes with a dry helium charge.
7. Corresponding refrigerant piping length is in accordance with standard length of each outdoor unit and the level difference is 0 ft. All capacities are net with a combination ratio between 95 - 105%.
8. Must follow installation instructions in the applicable LG installation manual.
9. Multi compatible 18k IDUs include socket adapters for refrigerant pipe connections with Multi F systems.



LSN181HSV5
Multi F Wall Mounted High Efficiency Indoor Unit
 18,000 Btu/h



Tag No.: _____

Date: _____

PO No.: _____

Unit : Inch (mm)

