

Job Name/Location:

Tag No:

Date:

For:	File	Resubmit
	Approval	Other

PO No.:

Architect: GC:

Engr: Mech:

Rep: (Company) (Project Manager)



# LMU243HV

## Multi F Inverter Heat Pump Outdoor Unit

**Performance:**

Cooling Capacity (Min.-Rated-Max., Btu/h)	8,400~24,000~25,000
Heating Capacity (Min.-Rated-Max., Btu/h)	10,080~24,600~29,000
Max. Heating Capacity at 5°F (Btu/h)	18,400
Max. Heating Capacity at 0°F (Btu/h)	16,730
Max. Heating Capacity at -4°F (Btu/h)	15,400
EER2	12.5
SEER2	22.5
COP	4.2
HSPF2	9.4

Cooling Nominal Test Conditions:  
Indoor: 80°F DB / 67°F WB  
Outdoor: 95°F DB / 75°F WB

Heating Nominal Test Conditions:  
Indoor: 70°F DB / 60°F WB  
Outdoor: 47°F DB / 43°F WB

**Operating Range:**

Cooling (°F DB)	14 to 118
Heating (°F WB)	-4 to +64

**Unit Data:**

Refrigerant Type	R410A
Refrigerant Control	EEV
Sound Pressure (Cool / Heat) ±1 dB(A) <sup>3</sup>	50 / 54
Net / Shipping Weight (lbs.)	101.4 / 110.2
Heat Exchanger Coating	Gold Fin™
Minimum No. of Indoor Units	2
Maximum No. of Indoor Units	3

**Electrical:**

Power Supply (V/Hz/Ø) <sup>1</sup>	208-230V, 60, 1
MOP (A)	20
MCA (A)	16.0
Recommended Fuse Size (A)	20
Cooling Rated Amps (A)	13.0
Heating Rated Amps (A)	13.0
Compressor (A)	12.0
Fan Motor (A)	0.40
Locked Rotor Amps (A)	16.0

MOP - Maximum Overcurrent Protection

MCA - Minimum Circuit Ampacity

**Compressor:**

Type	Twin Rotary
Quantity	1
Oil / Type	FVC68D

**Fan:**

Type	Propeller
Quantity	1
Motor / Drive	Brushless Digitally Controlled/Direct
Max. Airflow Rate (CFM)	1.766

**Piping:**

Refrigerant Charge (lbs.)	3.97
Liquid Line Connection (in., O.D.)	1/4 x 3
Vapor Line Connection (in., O.D.)	3/8 x 3
Maximum Total Piping <sup>2</sup> (ft.)	230.0
Min. / Max. ODU to IDU Piping (ft.)	9.8 / 82.0
Piping Length (no add'l refrigerant, ft.)	98.4
Maximum Elevation between ODU and IDU (ft.)	49.2
Maximum Elevation between IDU and IDU (ft.)	24.6

ODU = Outdoor Unit

IDU = Indoor Unit

**Features:**

- Auto operation
- Auto restart
- Inverter (variable speed compressor)
- Defrost / Deicing
- Restart delay (three [3] minutes)
- Self diagnosis
- Soft start
- Low ambient cooling down to 14°F

**Optional Accessories:**

- PI-485 - PMNFP14A1
- MultiSITE Comm. Mgr. - PBACNBTR0A
- AC Smart 5 - PACS5A000
- ACP 5 - PACP5A000
- Power Distribution Indicator (PDI) Premium - PQNUD1S41
- Mobile LGMV - PLGMVW100
- Drain Pan Heater - PQSH1203
- Low Ambient Baffle Kit (Cooling operation to -4°F) - ZLABGP03A



162279



For a complete list of available accessories, contact your LG representative.

For continual product development, LG reserves the right to change specifications without notice.

© LG Electronics U.S.A., Inc., Englewood Cliffs, NJ. All rights reserved. "LG Life's Good" is a registered trademark of LG Corp. /www.lghvac.com

SB\_MultiF\_LMU243HV\_2022\_07\_18\_084711

Job Name/Location: \_\_\_\_\_

# LMU243HV

## Multi F Inverter Heat Pump Outdoor Unit



Tag No.: \_\_\_\_\_

Date: \_\_\_\_\_

PO No.: \_\_\_\_\_

Unit: Inch  
☛ Gravity point

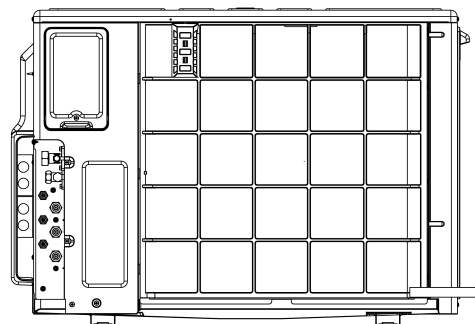
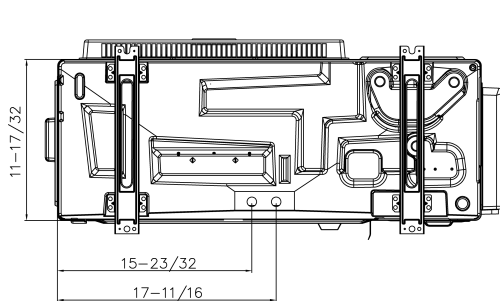
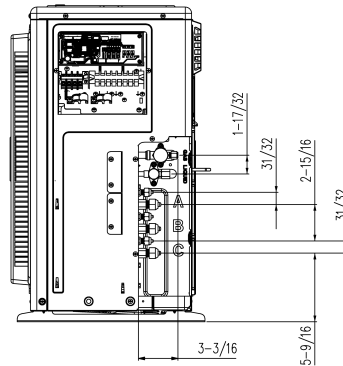
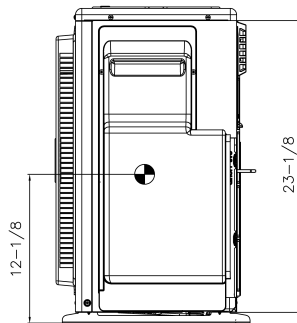
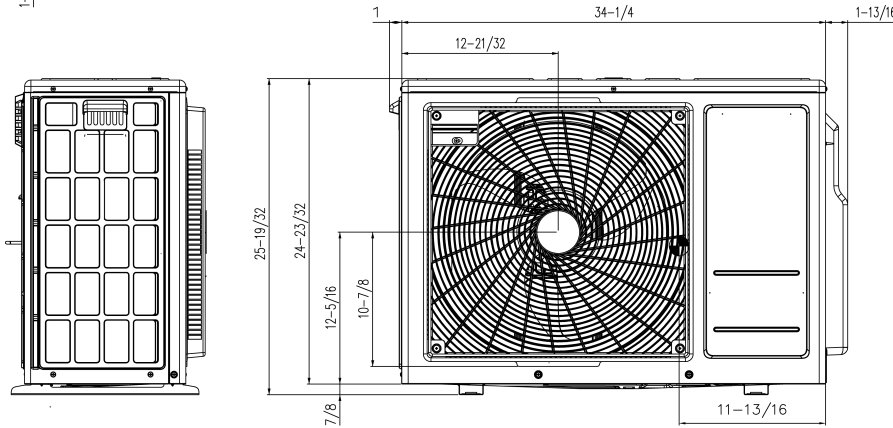
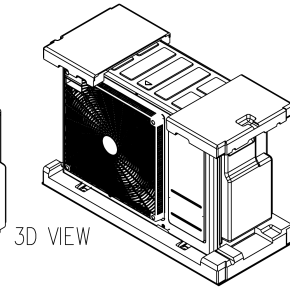
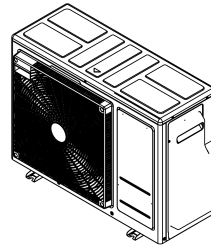
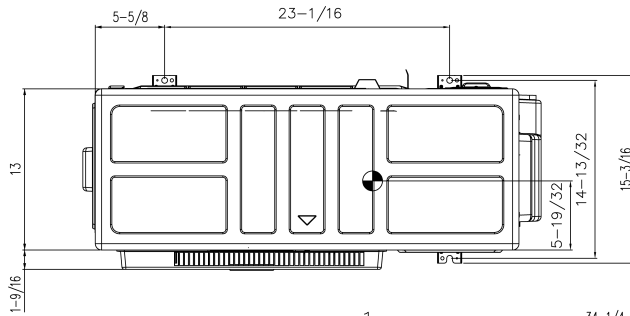

(BACK)

### Notes:

1. Unit must be installed in compliance with the installation manual.
2. Unit must be grounded in accordance with the local or state regulations and applicable national codes.
3. All field-supplied electrical components and materials must comply with the local, state, and national codes.
4. Electrical characteristics must be considered for electrical work and design. The capacity of power cable and circuit breaker for the outdoor unit must follow local, state, national, and manufacturer requirements.
5. For LMU183HV Unit, ports A and B are available.
6. For LMU243HV Unit, ports A, B, and C are available.

Job Name/Location:

Tag #:

Date:

For:	File	Resubmit
	Approval	Other_____

PO No.:

Architect: GC:

Engr: Mech:

Rep: (Company) (Project Manager)



**LMN159HVT**  
Multi F Wall Mounted High Efficiency Indoor Unit  
14,300 Btu/h



**Performance:**

Nominal Cooling Capacity (Btu/h)	14,300
Nominal Heating Capacity (Btu/h)	15,600

Cooling Nominal Test Conditions:  
Indoor: 80°F DB / 67°F WB  
Outdoor: 95°F DB / 75°F WB

Heating Nominal Test Conditions:  
Indoor: 70°F DB / 60°F WB  
Outdoor: 47°F DB / 43°F WB

**Electrical:**

Power Supply (V/Hz/Ø)	208-230/60/1
Rated Amps (A)	0.4

**Piping:**

Installed Liquid Pipe (in., O.D.)	Ø1/4
Installed Vapor Pipe (in., O.D.)	Ø3/8
Liquid Connection (in., O.D.)	Ø1/4
Vapor Connection (in., O.D.)	Ø3/8
Drain (in., O.D. / I.D.)	27/32 , 5/8
Temperature Sensor	Thermistor

**Controls Features:**

- 4-Way auto swing
- 24-Hour on/off timer
- Auto operation
- Auto restart
- Chaos wind
- Inverter (variable speed fan)
- Jet cool/Jet heat
- 3M Micro Dust Filter
- Self-cleaning indoor coil
- Sleep mode
- Condensate sensor connection
- Built-in Wi-Fi via Smart ThinQ app

**Included Accessories:**

- Wireless Remote Controller — AKB74955602

**Optional Accessories:**

- MultiSITE™ CRC1 - PREMTBVC0
- MultiSITE CRC1+ - PREMTBVC1
- Dry Contact - PDRYCB300

**Entering Mixed Air:**

Cooling (°F DB)	57 ~ 77
Heating (°F WB)	59 ~ 81

**Unit Data:**

Refrigerant Type	R410A
Refrigerant Control	EEV
Sound Pressure (H/M/L) (±3 dB[A]) <sup>2</sup>	42 / 38 / 32
Primary Filter	Washable Pre-filter
Secondary Filter	3M Micro Dust
Net Weight (lbs.)	18.3
Shipping Weight (lbs.)	23.4

**Fan:**

Type	Cross Flow
Quantity	1
Motor/Drive	Brushless Digitally Controlled/Direct
Air Flow H/M/L (CFM)	314 / 268 / 184

**Notes:**

1. Acceptable operating voltage: 187V-253V.
2. Sound Pressure levels are tested in an anechoic chamber under ISO Standard 3745.
3. See Engineering Manual for sensible and latent capacities.
4. All communication / connection (power) cable from the outdoor unit to the indoor unit is field supplied and must be a minimum of four-conductor, 18 AWG, stranded, shielded or unshielded (if shielded, it must be grounded to the chassis of the outdoor unit only), and must comply with applicable local and national codes.
5. Power wiring cable size must comply with the applicable local and national code.
6. The indoor unit comes with a dry helium charge.
7. Corresponding refrigerant piping length is in accordance with standard length of each outdoor unit and the level difference is 0 ft. All capacities are net with a combination ratio between 95 - 105%.
8. Must follow installation instructions in the applicable LG installation manual.



**LMN159HVT**  
 Multi F Wall Mounted High Efficiency Indoor Unit  
 14,300 Btu/h



Tag No.: \_\_\_\_\_

Date: \_\_\_\_\_

PO No.: \_\_\_\_\_

Unit : Inch (mm)

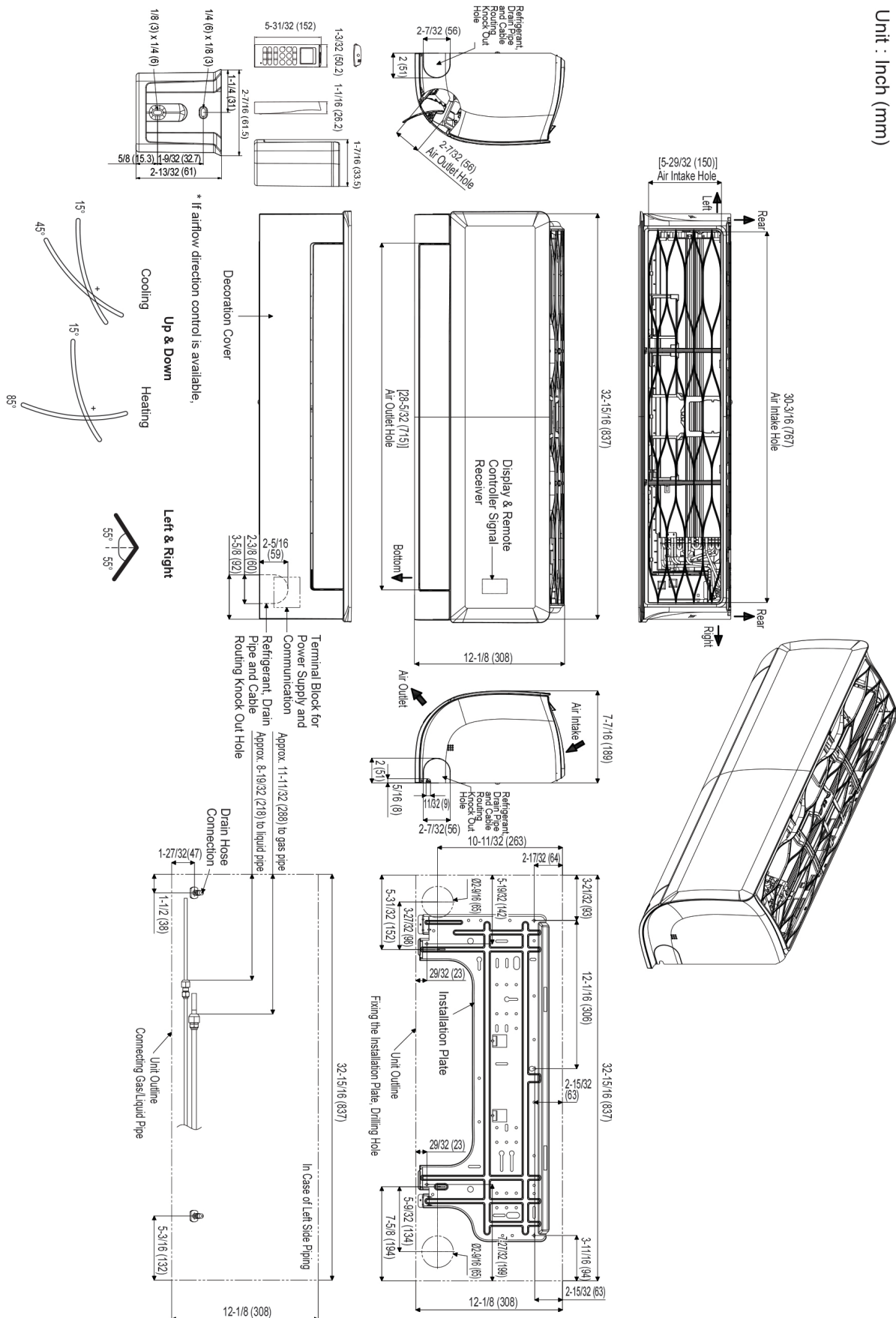

Job Name/Location:

Tag #:

Date:

For:	File	Resubmit
	Approval	Other_____

PO No.:

Architect: GC:

Engr: Mech:

Rep: (Company) (Project Manager)



**LMN159HVT**  
Multi F Wall Mounted High Efficiency Indoor Unit  
14,300 Btu/h



**Performance:**

Nominal Cooling Capacity (Btu/h)	14,300
Nominal Heating Capacity (Btu/h)	15,600

Cooling Nominal Test Conditions:  
Indoor: 80°F DB / 67°F WB  
Outdoor: 95°F DB / 75°F WB

Heating Nominal Test Conditions:  
Indoor: 70°F DB / 60°F WB  
Outdoor: 47°F DB / 43°F WB

**Electrical:**

Power Supply (V/Hz/Ø)	208-230/60/1
Rated Amps (A)	0.4

**Piping:**

Installed Liquid Pipe (in., O.D.)	Ø1/4
Installed Vapor Pipe (in., O.D.)	Ø3/8
Liquid Connection (in., O.D.)	Ø1/4
Vapor Connection (in., O.D.)	Ø3/8
Drain (in., O.D. / I.D.)	27/32 , 5/8
Temperature Sensor	Thermistor

**Controls Features:**

- 4-Way auto swing
- 24-Hour on/off timer
- Auto operation
- Auto restart
- Chaos wind
- Inverter (variable speed fan)
- Jet cool/Jet heat
- 3M Micro Dust Filter
- Self-cleaning indoor coil
- Sleep mode
- Condensate sensor connection
- Built-in Wi-Fi via Smart ThinQ app

**Included Accessories:**

- Wireless Remote Controller — AKB74955602

**Optional Accessories:**

- MultiSITE™ CRC1 - PREMTBVCO
- MultiSITE CRC1+ - PREMTBVC1
- Dry Contact - PDRYCB300

**Entering Mixed Air:**

Cooling (°F DB)	57 ~ 77
Heating (°F WB)	59 ~ 81

**Unit Data:**

Refrigerant Type	R410A
Refrigerant Control	EEV
Sound Pressure (H/M/L) (±3 dB[A]) <sup>2</sup>	42 / 38 / 32
Primary Filter	Washable Pre-filter
Secondary Filter	3M Micro Dust
Net Weight (lbs.)	18.3
Shipping Weight (lbs.)	23.4

**Fan:**

Type	Cross Flow
Quantity	1
Motor/Drive	Brushless Digitally Controlled/Direct
Air Flow H/M/L (CFM)	314 / 268 / 184

**Notes:**

1. Acceptable operating voltage: 187V-253V.
2. Sound Pressure levels are tested in an anechoic chamber under ISO Standard 3745.
3. See Engineering Manual for sensible and latent capacities.
4. All communication / connection (power) cable from the outdoor unit to the indoor unit is field supplied and must be a minimum of four-conductor, 18 AWG, stranded, shielded or unshielded (if shielded, it must be grounded to the chassis of the outdoor unit only), and must comply with applicable local and national codes.
5. Power wiring cable size must comply with the applicable local and national code.
6. The indoor unit comes with a dry helium charge.
7. Corresponding refrigerant piping length is in accordance with standard length of each outdoor unit and the level difference is 0 ft. All capacities are net with a combination ratio between 95 - 105%.
8. Must follow installation instructions in the applicable LG installation manual.



**LMN159HVT**  
**Multi F Wall Mounted High Efficiency Indoor Unit**  
 14,300 Btu/h



Tag No.: \_\_\_\_\_

Date: \_\_\_\_\_

PO No.: \_\_\_\_\_

Unit : Inch (mm)

