

# Constellation Grande

LP747\_ 1.0



## GENERAL PRODUCT INFORMATION:



This product is suitable for damp locations.

This product can be dimmed with a standard incandescent dimmer.

**CAUTION - RISK OF FIRE**  
 This product requires installation by a qualified electrician. Before installing be sure to read all instructions and **TURN THE POWER TO THE ELECTRICAL BOX OFF.**



## Preparing for Installation

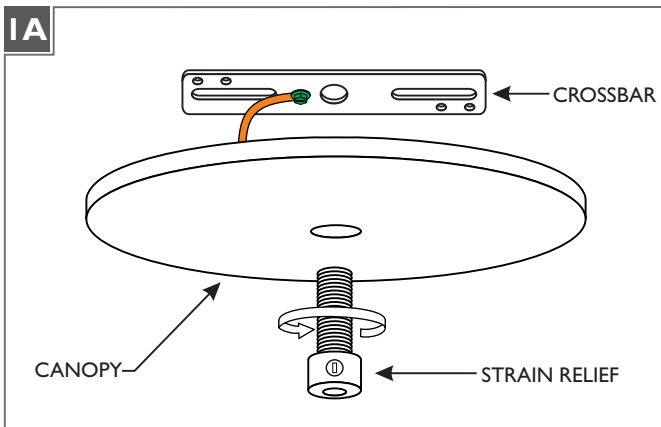

**1** Remove the crossbar from the canopy by completely unscrewing the strain relief.

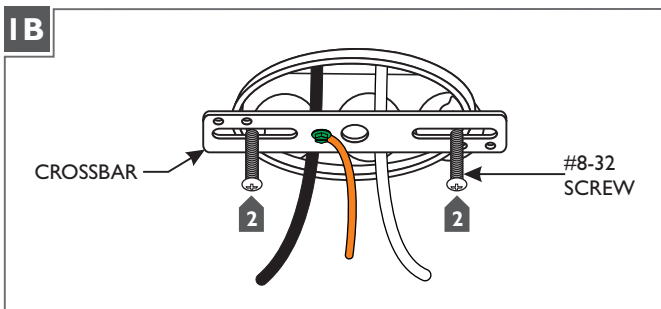

**2** Mount the crossbar assembly to the electrical box with the two provided #8-32 screws.

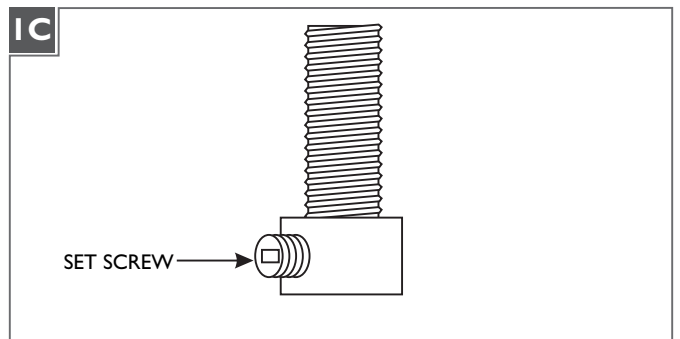

**3** Loosen (**Do Not Remove**) the set screw on the strain relief.

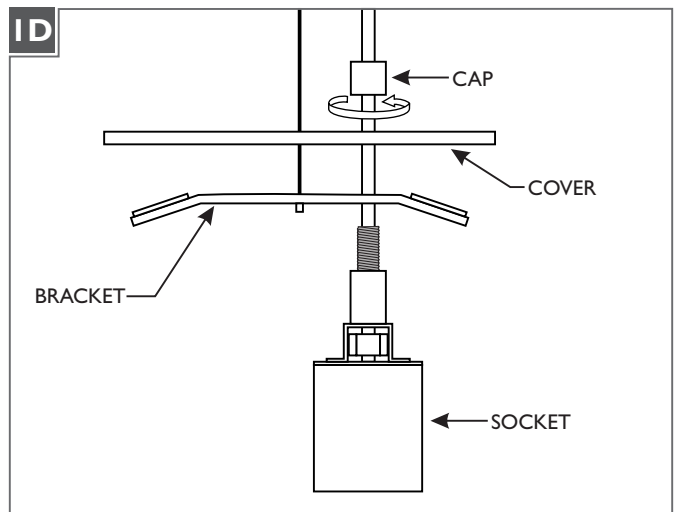

**4** Disassemble the socket assembly by unscrewing the cap and separating the socket, bracket, and the cover.

## Assemble the Fixture

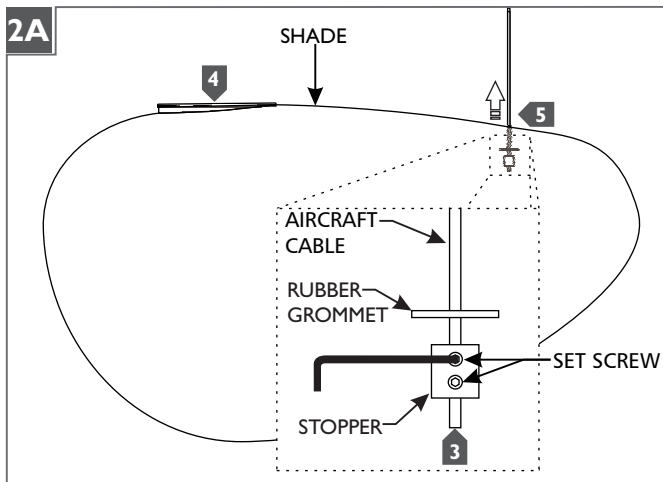

- 1 Loosen the two set screws on the stopper at the bottom of the cable post aircraft cable using the provided Allen wrench.
- 2 Determine the desired height of the fixture, move the stopper to the determined location, and tighten the two set screws on the stopper. **NOTE:** Take note of the height measurement, it will be needed for the canopy aircraft cable.
- 3 Cut off the excess aircraft cable.
- 4 Ensure that the rubber grommet is in place and install the separate aircraft cable into the shade.
- 5 Feed the open end through the small hole in the shade and pull it all the way through until the stopper is reached.

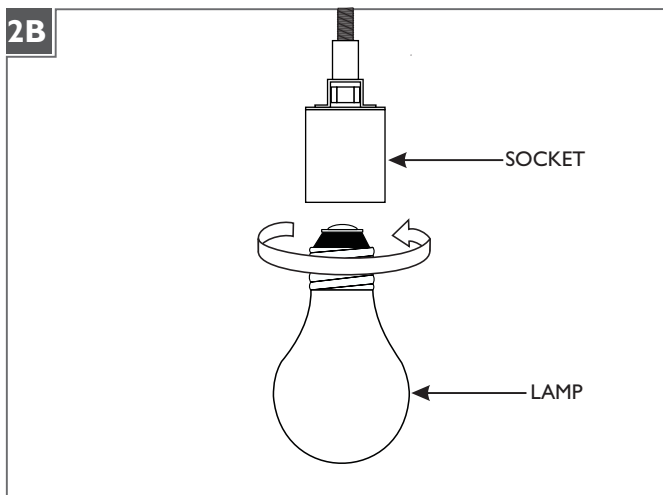

**CAUTION:** To reduce the risk of a burn or electric shock during relamping, disconnect the power to the fixture.

Use **MAX 75 Watt** type A19 medium base incandescent lamp.



- 6 Screw the lamp into the socket.

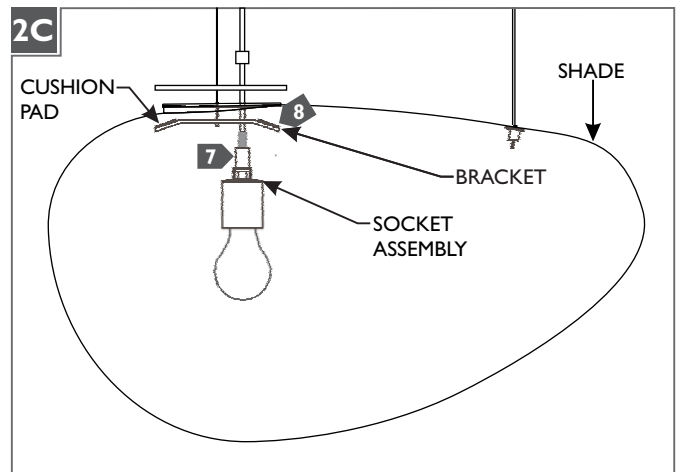

- 7 Place the socket assembly inside the shade.
- 8 Ensure that the cushion pads are in place and insert the bracket into the shade by slightly rotating it into place.

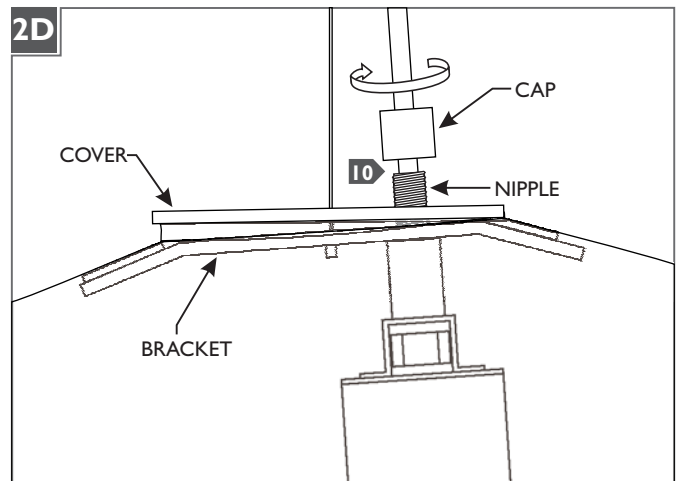

- 9 Place the socket nipple through the bracket hole and pull the assembly up until it rests inside the top of the shade.
- 10 Place the cover over the top of the shade opening lip, ensure that the bracket is centered and is gripping the shade properly, and secure it all by screwing on and tightening the cap.

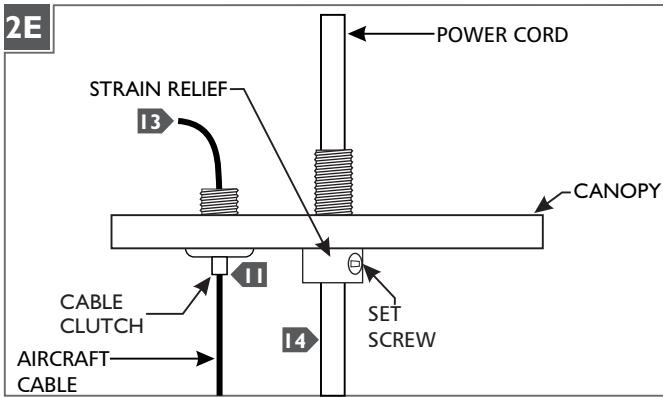

- 11** Feed the aircraft cable through the cable clutch in the canopy.
- 12** Pull the aircraft cable up through the canopy to raise the fixture to the determined length.
- 13** Cut off the excess aircraft cable leaving enough for fine leveling later.
- 14** If necessary loosen the set screw in the strain relief and feed the power cord from the fixture into the canopy port.

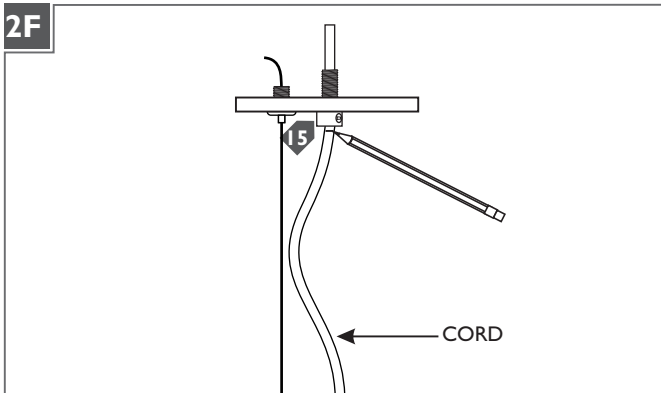

**NOTE:** The power cord does not support the fixture. For a casual "lazy cord" look, cut the power cord several inches longer than the drop height of the fixture.

- 15** Once the desired look is determined, tighten the set screw on the strain relief.
- 16** Mark the cord underneath the strain relief.

## Mount the Fixture

**CAUTION:** Make sure to support the fixture while installing, an assistant will be needed to complete the remaining steps.

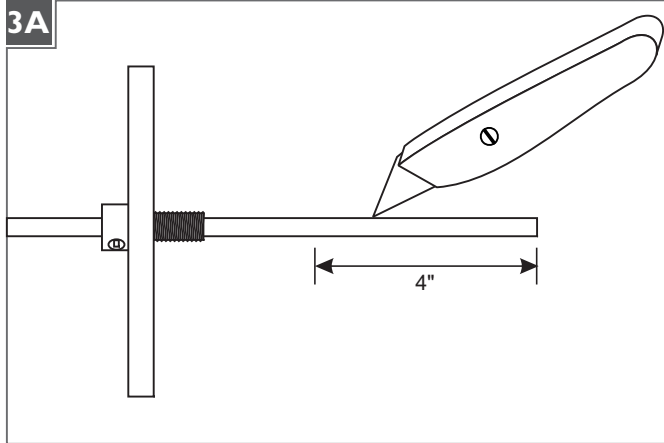

- 1** Leave 6" of the cord behind the canopy for power connections. Cut the excess cord.
- 2** From the end of the cord, strip the insulation 4" using a sharp knife. Make sure not to nick the inner wires.
- 3** Strip the end of the wires.

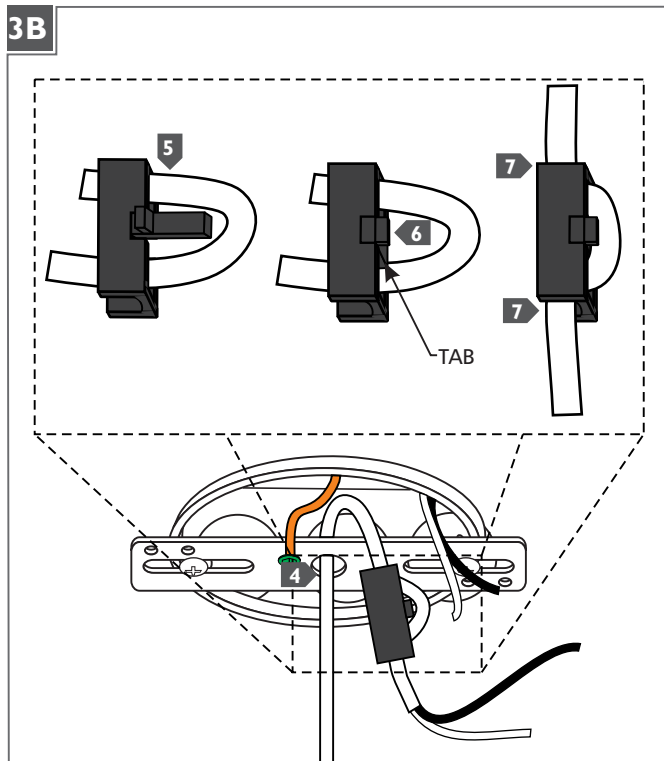

- 4** Feed the fixture wires through the crossbar center hole and then pull them out of the electrical box.
- 5** Install the secondary strain relief by first feeding the power cord through it.
- 6** Snap the strain relief tab into place.
- 7** Pull the cord to take up the slack and fit the rest of the cord in the strain relief's openings.

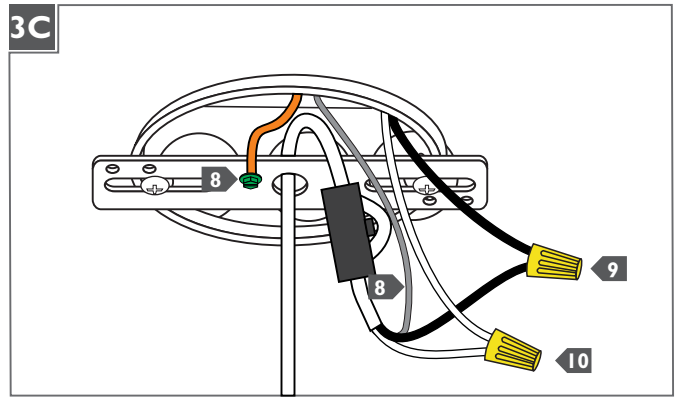

- 8** Connect the crossbar and the fixture ground wire to a suitable ground in accordance with local electrical codes.
- 9** Connect one fixture wire to the hot power line wire with a wire nut.
- 10** Connect the other fixture wire to the neutral power line wire with a wire nut.

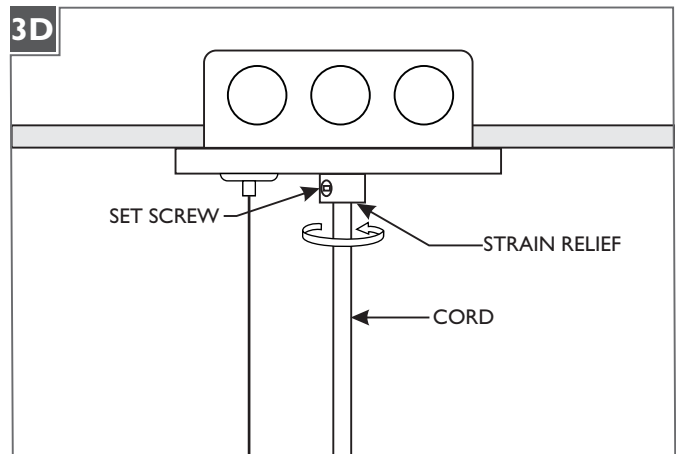

- 11** Place all wires, wire nut connections, and the secondary strain relief properly inside the electrical box.
- 12** Loosen the set screw on the primary strain relief.
- 13** Align the canopy center hole with the crossbar center hole.
- 14** Slide the canopy up against the ceiling and secure it in place by tightening the primary strain relief into the crossbar. Do not turn the cord.
- 15** Push the cord into the canopy and line up the marked point on the cord with bottom of the primary strain relief.
- 16** Tighten the plastic set screw to secure the cord.

**CAUTION:** CONTINUE TO SUPPORT THE SHADE!  
Do not let the fixture hang with out the completion of the cable standoff installation (next section).

## Install the Cable Post

**CAUTION:** Make sure to support the fixture while installing, an assistant will be needed to complete the remaining steps.

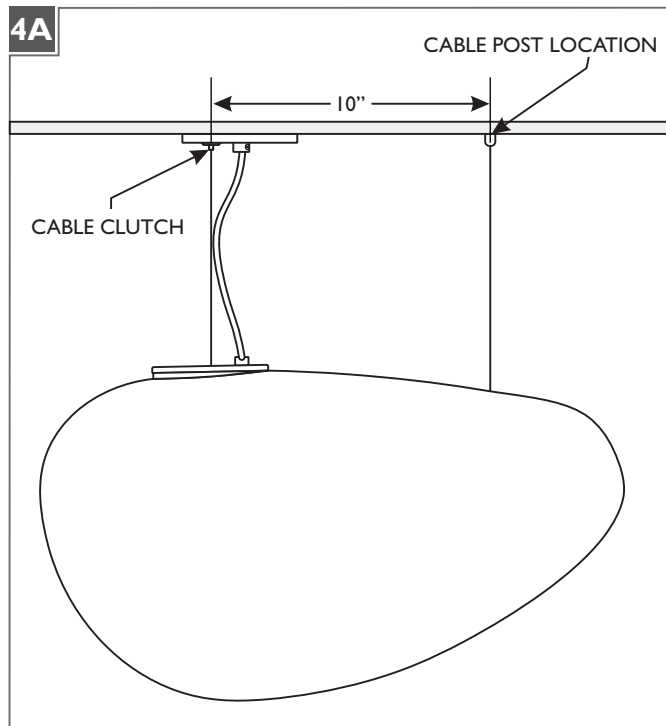

- 1 Mark the cable post location point 10" away from the center cable clutch on the canopy.

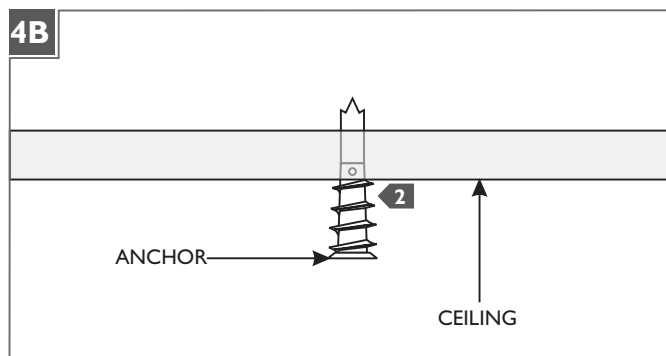

- 2 Tap the anchor at the marked point up to the threaded portion with a hammer.

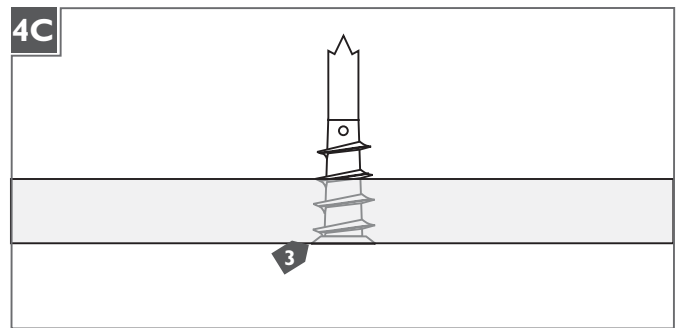

- 3 Screw the anchor in the rest of the way with a Phillips screwdriver.

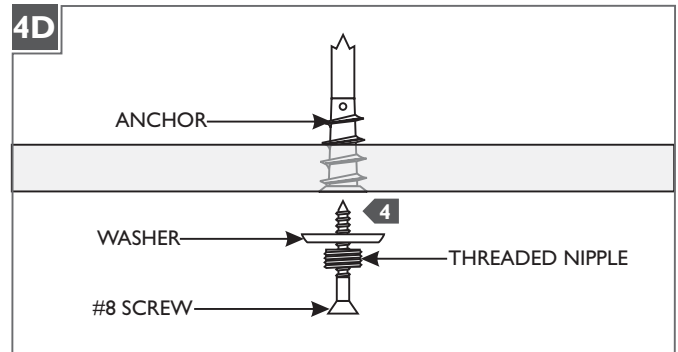

- 4 Insert the #8 screw into the threaded nipple and washer. Tighten the #8 screw completely into the anchor to secure the washer and threaded nipple in place.

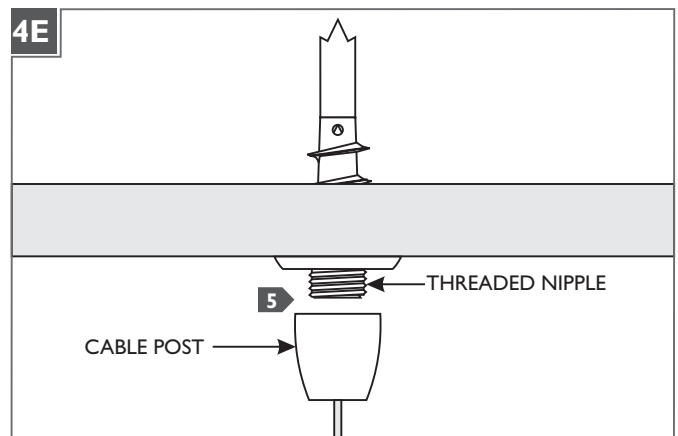

- 5 Screw the cable post completely to the threaded nipple.

## Adjust the Suspension Cable

**CAUTION:** Make sure to support the fixture while making adjustments, an assistant will be needed to complete this step.

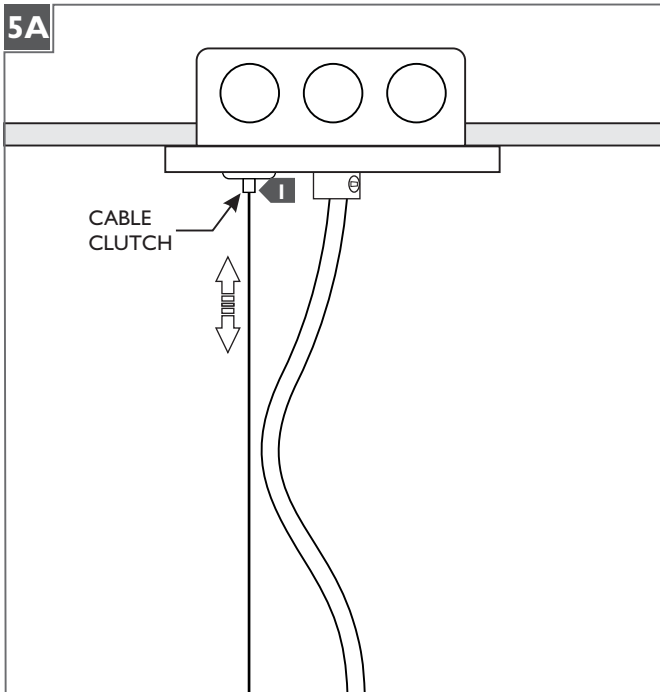

- I** If necessary, adjust the aircraft cable until the fixture is level; feed the cable into the cable clutch to raise the fixture and push in on the cable clutch nipple to release the cable and lower the fixture.



**SAVE THESE INSTRUCTIONS!**

**LBL**

7400 Linder Ave, Skokie, IL 60077

800.323.3226 - 847.626.6300

**[www.lblighting.com](http://www.lblighting.com)**

© 2013 LBL Lighting. All rights reserved. The "LBL Lighting" graphic is a registered trademark of LBL Lighting. LBL Lighting reserves the right to change specifications for product improvements without notification.

A Generation Brands Company